

REV SERIES

BOMBARDIER RECREATIONAL PRODUCTS INC.

TABLE OF CONTENTS

SAFETY NOTICE	XI
INTRODUCTION	XII
VEHICLE IDENTIFICATION NUMBER.....	XIV
ENGINE SERIAL NUMBER	XIV
LIST OF ABBREVIATIONS USED IN THIS MANUAL.....	XIV
ARRANGEMENT OF THIS MANUAL	XVI
GENERAL INFORMATION.....	XVIII
ILLUSTRATIONS AND PROCEDURES	XVIII
SELF-LOCKING FASTENERS PROCEDURE	XVIII
LOCTITE APPLICATION PROCEDURE.....	XIX
THREADLOCKER	XIX
STRIPPED THREAD REPAIR	XX
GASKET COMPOUND	XXI
MOUNTING ON SHAFT	XXI
CASE-IN COMPONENTS	XXII
TIGHTENING TORQUE	XXIII
01 MAINTENANCE	
01 – MAINTENANCE CHART	1
02 – STORAGE	3
GENERAL	3
ENGINE	3
FUEL SYSTEM.....	4
DRIVE SYSTEM	4
STEERING/FRONT SUSPENSION	5
SUSPENSION.....	5
ELECTRICAL.....	5
VEHICLE	5
03 – PRESEASON PREPARATION	7
ENGINE	7
FUEL SYSTEM.....	7
DRIVE SYSTEM	8
ELECTRICAL SYSTEM.....	8
VEHICLE	8
02 TROUBLESHOOTING	
01 – ENGINE	9
02 – FUEL AND OIL SYSTEMS	21
03 – DRIVE AND BRAKE SYSTEMS	25
DRIVE SYSTEM	25
BRAKE SYSTEM.....	32
04 – ELECTRICAL SYSTEM	33
05 – STEERING AND SUSPENSION	43
03 ENGINES	
01 – LEAK TEST	47
PREPARATION	47
PROCEDURE	48
FINALIZING REASSEMBLY.....	49
ENGINE LEAK VERIFICATION FLOW CHART	50

TABLE OF CONTENTS

02 – EXHAUST SYSTEM.....	51
377 AND 552 ENGINES	52
593, 593 HO, 593 HO SDI AND 793 HO ENGINES	53
TUNED PIPE	54
MANIFOLD	55
MUFFLER.....	55
03 – ENGINE REMOVAL AND INSTALLATION	57
REMOVAL FROM VEHICLE	59
INSPECTION.....	63
INSTALLATION	63
REMOVAL FROM VEHICLE	65
INSPECTION.....	69
INSTALLATION	69
04 – MAGNETO SYSTEM.....	71
GENERAL	76
MAGNETO FLYWHEEL	76
STATOR	78
CPS/TRIGGER COIL.....	78
05 – TOP END.....	81
TROUBLESHOOTING.....	84
CLEANING	84
DISASSEMBLY	84
INSPECTION.....	86
ASSEMBLY	86
TROUBLESHOOTING.....	98
COMPONENT REMOVAL WITH THE ENGINE INSTALLED	98
CLEANING	98
RAVE VALVE BASIC OPERATION	98
DISASSEMBLY	98
INSPECTION.....	103
ASSEMBLY	104
06 – BOTTOM END	109
CLEANING	112
DISASSEMBLY	112
INSPECTION.....	113
ASSEMBLY	113
BREAK-IN	118
CLEANING	122
DISASSEMBLY	122
INSPECTION.....	123
ASSEMBLY	123
BREAK-IN	128
07 – ENGINE MEASUREMENT	129
CYLINDER HEAD WARPAGE	129
CYLINDER TAPER.....	129
CYLINDER OUT OF ROUND	129
COMBUSTION CHAMBER VOLUME MEASUREMENT	130
USED PISTON MEASUREMENT.....	131
CYLINDER/PISTON CLEARANCE.....	131
RING/PISTON GROOVE CLEARANCE.....	133
RING END GAP.....	133
CRANKSHAFT DEFLECTION.....	133

TABLE OF CONTENTS

CONNECTING ROD BIG END AXIAL PLAY	134
CHECKING CRANKSHAFT ALIGNMENT	134
08 – COOLING SYSTEM	135
COOLING FAN REMOVAL AND INSTALLATION	138
COOLING FAN BEARING REPLACEMENT	138
FAN BELT REPLACEMENT AND DEFLECTION ADJUSTMENT	139
LIQUID COOLING SYSTEM	142
COOLING SYSTEM LEAK TEST	145
INSPECTION	145
DRAINING THE SYSTEM	145
DISASSEMBLY AND ASSEMBLY	145
COOLING SYSTEM REFILLING PROCEDURE	146
09 – REWIND STARTER	147
INSPECTION	150
REMOVAL	150
ROPE REPLACEMENT	150
DISASSEMBLY	151
ASSEMBLY	151
INSTALLATION	154
10 – OIL INJECTION SYSTEM	155
GENERAL	158
OIL TYPE	158
OIL SYSTEM LEAK TEST	158
OIL PUMP IDENTIFICATION	159
CLEANING	159
CHECKING OPERATION	159
DISASSEMBLY	160
ASSEMBLY	161
BLEEDING PROCEDURE	162
ADJUSTMENT	162
<hr/>	
04 FUEL SYSTEM	
01 – FUEL TANK AND FUEL PUMP	165
IN-TANK FUEL FILTER	168
IN-LINE FUEL FILTER	168
FUEL TANK	169
FLOAT-TYPE FUEL LEVEL GAUGE	170
ELECTRIC FUEL LEVEL SENSOR	171
FUEL SYSTEM PRESSURIZATION	171
DIAPHRAGM FUEL PUMP	172
REMOVAL	174
PUMP VERIFICATION	174
CLEANING AND INSPECTION	174
INSTALLATION	174
02 – CARBURETORS, THROTTLE AND CHOKE CABLES	175
CARBURETOR — VM TYPE	176
IDENTIFICATION	177
REMOVAL	177
CLEANING AND INSPECTION	177
DISASSEMBLY AND ASSEMBLY	177
CARBURETOR ADJUSTMENTS	178
INSTALLATION	181

TABLE OF CONTENTS

CHOKE	182
CARBURETOR TM TYPE	184
IDENTIFICATION	185
REMOVAL	185
CLEANING AND INSPECTION	187
DISASSEMBLY AND ASSEMBLY	187
INSTALLATION	189
CARBURETOR ADJUSTMENTS	189
CHOKE CABLE	191
03 – DPM SYSTEM	193
OVERVIEW	195
SYSTEM TESTING	195
PARTS REMOVAL AND INSTALLATION	195
DPM MANIFOLD TESTING	196
<hr/>	
05 ENGINE MANAGEMENT (POWER TEK)	199
01 – OVERVIEW	199
OPERATING PRINCIPLE	200
FUEL DELIVERY SYSTEM	200
ENGINE MANAGEMENT SYSTEM (EMS)	200
EMS — ENGINE MANAGEMENT SYSTEM FUNCTIONS	201
POWER DISTRIBUTION	202
IGNITION SYSTEM	202
ELECTRONICALLY CONTROLLED RAVE	202
DIGITALLY ENCODED SECURITY SYSTEM (DESS)	202
ROTAX ELECTRONIC REVERSE (RER)	203
MONITORING SYSTEM	203
DIAGNOSTIC MODE	203
02 – DIAGNOSTIC PROCEDURES	205
GENERAL	205
TROUBLESHOOTING	205
EMS FAULT CODES	206
VCK (VEHICLE COMMUNICATION KIT)	209
03 – COMPONENT INSPECTION, REPLACEMENT AND ADJUSTMENT	213
GENERAL	213
ELECTRICAL SYSTEM	213
FUEL SYSTEM	215
ENGINE MANAGEMENT SYSTEM	216
ENGINE CONTROL MODULE (ECM)	216
POWER RELAY	216
THROTTLE POSITION SENSOR (TPS)	217
AIR TEMPERATURE SENSOR (ATS)	221
COOLANT TEMPERATURE SENSOR (CTS)	222
AIR PRESSURE SENSOR (APS)	223
KNOCK SENSOR (KS)	224
E-RAVE SOLENOID	225
DPM SOLENOID	226
IGNITION COIL	226
ENGINE START/RER SWITCH	227
DIGITALLY ENCODED SECURITY SYSTEM (DESS)	228

06	ENGINE MANAGEMENT (SDI)	
01	– OVERVIEW	231
	OPERATING PRINCIPLE	232
	CHARGING SYSTEM	232
	IGNITION SYSTEM	232
	AIR INDUCTION	232
	FUEL DELIVERY SYSTEM	233
	ENGINE MANAGEMENT SYSTEM (EMS)	234
	ECM — GENERAL FUNCTIONS	235
	EMS — ENGINE MANAGEMENT SYSTEM FUNCTIONS	237
	ELECTRONIC FUEL INJECTION	237
	IGNITION TIMING	238
	ELECTRONICALLY CONTROLLED RAVE	238
	KNOCK SENSOR	238
	ENGINE MODES OF OPERATION	238
	FLOODED ENGINE (DROWNED MODE)	238
	MONITORING SYSTEM	238
	LIMP HOME MODES	238
	DIAGNOSTIC MODE	239
	ROTAX ELECTRONIC REVERSE (RER)	239
02	– DIAGNOSTIC PROCEDURES	241
	GENERAL	241
	TROUBLESHOOTING	241
	VCK (VEHICLE COMMUNICATION KIT)	245
	2-TEC SYSTEM FAULT CODES	247
03	– COMPONENT INSPECTION, REPLACEMENT AND ADJUSTMENT	249
	GENERAL	249
	FUEL SYSTEM	249
	ELECTRICAL SYSTEM	250
	RESISTANCE MEASUREMENT	251
	ENGINE CONNECTOR PIN-OUTS	252
	RELAY	253
	AIR INDUCTION SYSTEM	254
	THROTTLE BODY	254
	FUEL DELIVERY	257
	ELECTRIC FUEL PUMP	258
	FUEL RAIL	261
	FUEL INJECTORS	262
	ELECTRONIC MANAGEMENT	265
	ECM REPLACEMENT	265
	ENGINE WIRING HARNESS	265
	THROTTLE POSITION SENSOR (TPS)	266
	CRANKSHAFT POSITION SENSOR (CPS)	268
	AIR TEMPERATURE SENSOR (ATS)	269
	COOLANT TEMPERATURE SENSOR (CTS)	270
	AIR PRESSURE SENSOR (APS)	271
	EXHAUST GAS TEMPERATURE SENSOR (EGTS)	271
	KNOCK SENSOR (KS)	272
	E-RAVE SOLENOID	273
	DOUBLE IGNITION COIL	273
	IGNITION TIMING	275
	BATTERY	275

TABLE OF CONTENTS

CAPACITOR.....	275
ENGINE START/REAR SWITCH VERIFICATION.....	276
DESS POST VERIFICATION.....	277

07 ELECTRICAL SYSTEM

01 – IGNITION SYSTEM	279
GENERAL.....	279
IGNITION TIMING.....	282
SPARK PLUG.....	291
DESIGN SYMBOLS USED IN NGK SPARK PLUGS.....	292
02 – CHARGING SYSTEM	293
GENERAL.....	293
CHARGING GENERATOR COIL (STATOR).....	293
VOLTAGE REGULATOR/RECTIFIER.....	294
BATTERY.....	295
CABLE TERMINAL INSTALLATION.....	297
03 – STARTING SYSTEM	299
TROUBLESHOOTING.....	301
04 – ACCESSORIES.....	307
GENERAL.....	307
12-VOLT POWER OUTLET (CIGARETTE-LIGHTER TYPE).....	308
BEEPER (REVERSE ALARM).....	308
ENGINE TEMPERATURE GAUGE.....	309
ELECTRIC FUEL GAUGE.....	310
HEADLAMP.....	310
HEADLAMP BEAM AIMING.....	311
HEATING ELEMENTS.....	312
RELAY.....	312
SPEEDOMETER.....	313
SPEED SENSOR.....	313
TACHOMETER.....	314
TAILLIGHT.....	314
VISOR OUTLET.....	315

08 DRIVE SYSTEM

01 – DRIVE BELT	317
APPLICATION CHART.....	317
INSPECTION.....	317
CHECKING NEUTRAL FUNCTION.....	317
ROTATION DIRECTION.....	317
DRIVE BELT HEIGHT MEASUREMENT AND ADJUSTMENT.....	318
DRIVE BELT DEFLECTION MEASUREMENT (REFERENCE ONLY).....	320
02 – DRIVE PULLEY.....	323
BOMBARDIER LITE	324
GENERAL.....	325
REMOVAL.....	325
DISASSEMBLY.....	325
CLEANING.....	326
INSPECTION.....	326
ASSEMBLY.....	326
INSTALLATION.....	327
TRA III.....	328

TABLE OF CONTENTS

GENERAL	329
REMOVAL	329
DISASSEMBLY	329
CLEANING	331
INSPECTION	331
ASSEMBLY	333
INSTALLATION	337
DRIVE PULLEY ADJUSTMENT	337
03 – DRIVEN PULLEY	339
FORMULA RER AND FORMULA VSA-R	340
REMOVAL	341
DISASSEMBLY	341
CLEANING	341
INSPECTION	341
BUSHING REPLACEMENT	342
ASSEMBLY	342
INSTALLATION	343
ADJUSTMENT	344
HPV VSA	345
REMOVAL	346
DISASSEMBLY	346
CLEANING	346
INSPECTION	346
ASSEMBLY	346
INSTALLATION	347
ADJUSTMENT	347
04 – PULLEY ALIGNMENT	349
GENERAL	349
MEASURING PROCEDURE	349
ALIGNMENT PROCEDURE	351
05 – BRAKE	353
HYDRAULIC BRAKE	354
BRAKE FLUID	355
MASTER CYLINDER	355
CALIPER	355
BRAKE PADS	356
BRAKE DISC	357
COUNTERSHAFT BEARING	357
COUNTERSHAFT	358
BRAKE LIGHT SWITCH	358
BLEEDING	359
06 – CHAINCASE	361
GENERAL	363
CHAINCASE OIL LEVEL	363
OIL CHANGE	363
DRIVE CHAIN ADJUSTMENT	364
REMOVAL AND DISASSEMBLY	364
INSPECTION	365
INSTALLATION AND ASSEMBLY	365
SILENT CHAIN	365
07 – DRIVE AXLE	367
REMOVAL	371

TABLE OF CONTENTS

ASSEMBLY	372
LUBRICATION	373
ADJUSTMENT	373
08 – TRACK	375
TRACK TYPE APPLICATION	375
GENERAL	375
INSPECTION	375
REMOVAL	375
INSTALLATION	375
ADJUSTMENT	375
TRACK CLEAT	377
TRACTION ENHANCING PRODUCTS (STUDS)	377
<hr/>	
09 REAR SUSPENSION	381
01 – SC SUSPENSION	381
AXLE SELF-LOCKING SCREWS REMOVAL	386
REAR AXLE REMOVAL	386
REAR AXLE INSTALLATION	386
REAR SHOCK ABSORBER REMOVAL	386
REAR SHOCK ABSORBER INSTALLATION	387
FRONT SHOCK ABSORBER REMOVAL	387
FRONT SHOCK ABSORBER INSTALLATION	387
REAR SPRING REMOVAL	388
REAR SPRING INSTALLATION	388
SLIDER SHOE VERIFICATION	388
SLIDER SHOE REMOVAL	389
SLIDER SHOE INSTALLATION	390
SUSPENSION REMOVAL	390
SUSPENSION INSTALLATION	391
FRONT ARM REMOVAL	391
FRONT ARM INSTALLATION	391
REAR ARM/PIVOT ARM REMOVAL	392
REAR ARM INSTALLATION	392
STOPPER STRAP	392
RIDE ADJUSTMENT	393
LUBRICATION	393
02 – SC 3 SUSPENSION	395
AXLE SELF-LOCKING SCREWS REMOVAL	399
REAR AXLE REMOVAL	399
REAR AXLE INSTALLATION	399
REAR SHOCK ABSORBER REMOVAL	399
REAR SHOCK ABSORBER INSTALLATION	400
FRONT SHOCK ABSORBER REMOVAL	400
FRONT SHOCK ABSORBER INSTALLATION	400
REAR SPRING REMOVAL	400
REAR SPRING INSTALLATION	401
SLIDER SHOE VERIFICATION	402
SLIDER SHOE REMOVAL	402
SLIDER SHOE INSTALLATION	403
SUSPENSION REMOVAL	403
SUSPENSION INSTALLATION	404
FRONT ARM REMOVAL	404

TABLE OF CONTENTS

FRONT ARM INSTALLATION	405
REAR ARM/PIVOT ARM REMOVAL	405
REAR ARM/PIVOT ARM INSTALLATION	405
STOPPER STRAP	406
RIDE ADJUSTMENT	406
LUBRICATION	406
03 – SC 4 SUSPENSION	409
AXLE SELF-LOCKING SCREW REMOVAL	413
REAR AXLE REMOVAL	413
REAR AXLE INSTALLATION	413
REAR SHOCK ABSORBER REMOVAL	413
REAR SHOCK ABSORBER INSTALLATION	414
FRONT SHOCK ABSORBER REMOVAL	414
FRONT SHOCK ABSORBER INSTALLATION	415
REAR SPRING REMOVAL	415
REAR SPRING INSTALLATION	416
SLIDER SHOE VERIFICATION	416
SLIDER SHOE REMOVAL	417
SLIDER SHOE INSTALLATION	418
SUSPENSION REMOVAL	418
SUSPENSION INSTALLATION	418
FRONT ARM REMOVAL	418
FRONT ARM INSTALLATION	419
REAR ARM/PIVOT ARM REMOVAL	419
REAR ARM/PIVOT ARM INSTALLATION	419
BLOCK INSTALLATION	420
IDLER WHEELS INSTALLATION	420
STOPPER STRAP	420
RIDE ADJUSTMENT	420
LUBRICATION	421
04 – SHOCK ABSORBER INSPECTION AND SERVICING	423
SPRING REMOVAL	423
SHOCK ABSORBER INSPECTION	424
DISASSEMBLY AND ASSEMBLY	425
<hr/>	
10 STEERING/FRONT SUSPENSION	433
01 – STEERING SYSTEM	433
DISASSEMBLY AND ASSEMBLY	437
INSPECTION	440
ADJUSTMENT	440
STEERING ADJUSTMENT (SKIS)	444
LUBRICATION	446
02 – FRONT SUSPENSION	447
GENERAL INSPECTION	450
DISASSEMBLY	450
INSPECTION	454
INSTALLATION	455
<hr/>	
11 BODY/FRAME	461
01 – BODY	461
INSTALLATION AND ADJUSTMENT	461
DECAL	461

TABLE OF CONTENTS

WINDSHIELD.....	461
GUARD.....	461
WIRING HARNESS.....	461
CABLES.....	462
TUBING.....	462
PLASTIC MAINTENANCE AND REPAIR.....	462
MAINTENANCE.....	462
REPAIR.....	462
02 – FRAME.....	463
FRAME CLEANING.....	463
FRAME WELDING.....	463
FRAME COMPONENT REPLACEMENT.....	463
<hr/>	
12 TECHNICAL DATA.....	
01 – FAN COOLED MODELS.....	465
02 – LIQUID COOLED MODELS.....	471
03 – LIQUID COOLED (SDI) MODELS.....	479
<hr/>	
13 WIRING DIAGRAM.....	
01 – WIRING DIAGRAMS.....	485
WIRING DIAGRAM LEGEND.....	485
WIRE COLORS.....	485
CONNECTOR HOUSING AREA.....	485
HOUSING REFERENCE PER AREA.....	486
WIRE LOCATION IN CONNECTOR HOUSING.....	486
SYMBOLS DESCRIPTION.....	488
UNPLUGGING CONNECTORS.....	489
TAB AND RECEPTACLE CONNECTORS REMOVAL.....	489
TAB AND RECEPTACLE CONNECTORS INSTALLATION.....	495

INTRODUCTION

MODEL	ENGINE	MODEL NUMBER
EXPEDITION	550F	FJ5A, FJ5B
GSX	380F	DG5B
	550F	DF5A
	500 SS	DC5A, DC5B
	600 HO	DB5A, DB5B
	600 HO SDI	DD5A, DD5B, DE5A, DE5B
	800 HO DPM Power Tek	DA5A, DA5B
GTX	380F	EM5A, EM5B
	550F	EL5A, EL5B
	500 SS	ED5A, ED5B, ED5C
	600 HO	EC5A, EC5B
	600 HO SDI	EH5A, EH5B, EJ5A, EJ5B, EJ5C
	800 HO DPM Power Tek	EA5A, EA5B, EA5C
MX Z	380F	BR5A, BR5B, BR5C
	550F	BP5A, BP5B, BP5C
	500 SS	BF5A, BF5B, BF5C, BF5G, BF5H, BF5J, BF5L, BH5B, BH5C, BH5D, BH5A, BH5E
	600 HO	BC5A, BC5C, BC5F, BC5G, BC5H, BC5J, BC5K, BC5L, BC5M, BE5A, BE5B, BE5C, BE5G, BE5H, BE5J, BE5K, BE5L, BE5M, BE5N, BG5A, BG5B, BV5A, BV5B, BV5C, BV5D
	600 HO SDI	BK5A, BK5B, BK5C, BK5D, BK5F, BK5G, BK5H, BK5J, BK5K, BK5L, BK5M, BK5N, BL5A, BL5B, BL5C, BL5G, BL5H, BL5J, BL5K, BL5L, BL5M, BW5C, BW5F, BW5G, BW5H, BW5J, BW5K, BW5L, BW5M, BX5C, BX5D, BX5E, BX5F, BX5G
MX Z (Adrenaline)	800 HO	BD5A, BD5B, BD5C, BD5G, BD5H, BD5J, BD5K, BD5L, BD5M
MX Z	800 HO DPM Power Tek	BB5A, BB5B, BB5C, BB5D, BB5F, BB5G, BB5H, BB5J, BB5K, BB5L, BB5M, BB5N, BS5C, BS5D, BS5E, BS5F, BS5G, BS5H, BS5J, BS5K, BS5L, BS5M, BS5N, BU5A, BU5B, BU5C, BU5D
SUMMIT	550F	CM5A, CM5B
	800 HO DPM	CG5A, CG5B, CG5C, CG5D, CH5A, CH5B, CH5C, CH5D, CJ5A, CJ5B, CJ5C, CK5A, CK5B, CL5A, CL5B, CL5C, CP5A, CP5B, CP5C, CP5D

INTRODUCTION

VEHICLE IDENTIFICATION NUMBER

Vehicle Identification Number Location

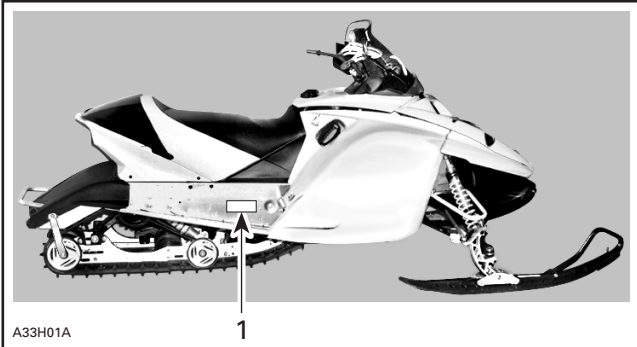

TYPICAL
1. Vehicle identification number

Identification Number Meaning

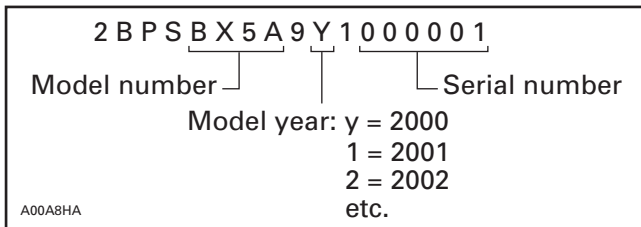

ENGINE SERIAL NUMBER

Engine Serial Number Location

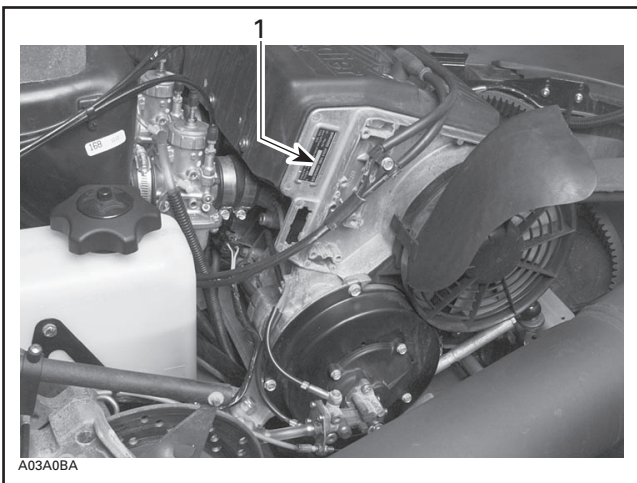

TYPICAL — 2-STROKE FAN-COOLED ENGINES
1. Engine serial number

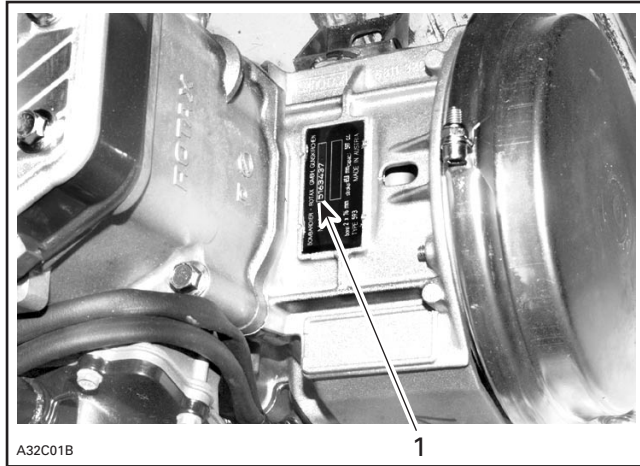

TYPICAL — 2-STROKE LIQUID-COOLED ENGINES
1. Engine serial number

LIST OF ABBREVIATIONS USED IN THIS MANUAL

ABBREVIATION	MEANING
A	ampere
amp	ampere
A•h	ampere-hour
AC	alternate current
ACM	acceleration and control modulator
AMG	absorbed glass mat
BDC	bottom dead center
BTDC	before top dead center
°C	degree Celsius
cc	cubic centimeter
CDI	capacitor discharge ignition
CTR	center
cm	centimeter
cm ²	square centimeter
cm ³	cubic centimeter
DC	direct current
DESS	digitally encoded security system
DPM	digital performance management

INTRODUCTION

ABBREVIATION	MEANING
°F	degree Fahrenheit
FC	fan cooled
fl. oz	fluid ounce
ft	foot
GRD	ground
H.A.C.	high altitude compensator
hal.	halogen
HI	high
IFP	internal floating piston
imp. oz	imperial ounce
in	inch
in ²	square inch
in ³	cubic inch
k	kilo (thousand)
kg	kilogram
km/h	kilometer per hour
kPa	Kilopascal
L	liter
lb	pound
lbf	pound (force)
lbf/in ²	pound per square inch
LH	left hand
LO	low
LT	long track
m	meter
MAG	magneto
Max.	maximum
Min.	minimum
mL	milliliter
mm	millimeter
M.E.	millennium edition
MPEM	multi-purpose electronic module
MPH	mile per hour
N	newton

ABBREVIATION	MEANING
N.A.	not applicable
no.	number
0	continuity
0.L	open line (open circuit)
O.D.	outside diameter
OPT	optional
oz	ounce
P/N	part number
PSI	pound per square inch
PTO	power take off
R	rectangular
RH	right hand
R.A.S.	response angle suspension
RAVE	Rotax adjustable variable exhaust
RER	Rotax electronic reverse
RPM	revolution per minute
RMS	root mean square
RRIM	reinforced reaction injection molding
SDI	semi-direct injection
Sp. Gr.	specific gravity
ST	semi-trapez
TDC	top dead center
TRA	total range adjustable
U.S. oz	ounce (United States)
V	volt
Vac	volt (alternative current)
VSA	variable sheave angle

INTRODUCTION

ARRANGEMENT OF THIS MANUAL

This *Shop Manual* uses technical terms which may be slightly different from the ones in the parts catalog.

TYPICAL PAGE

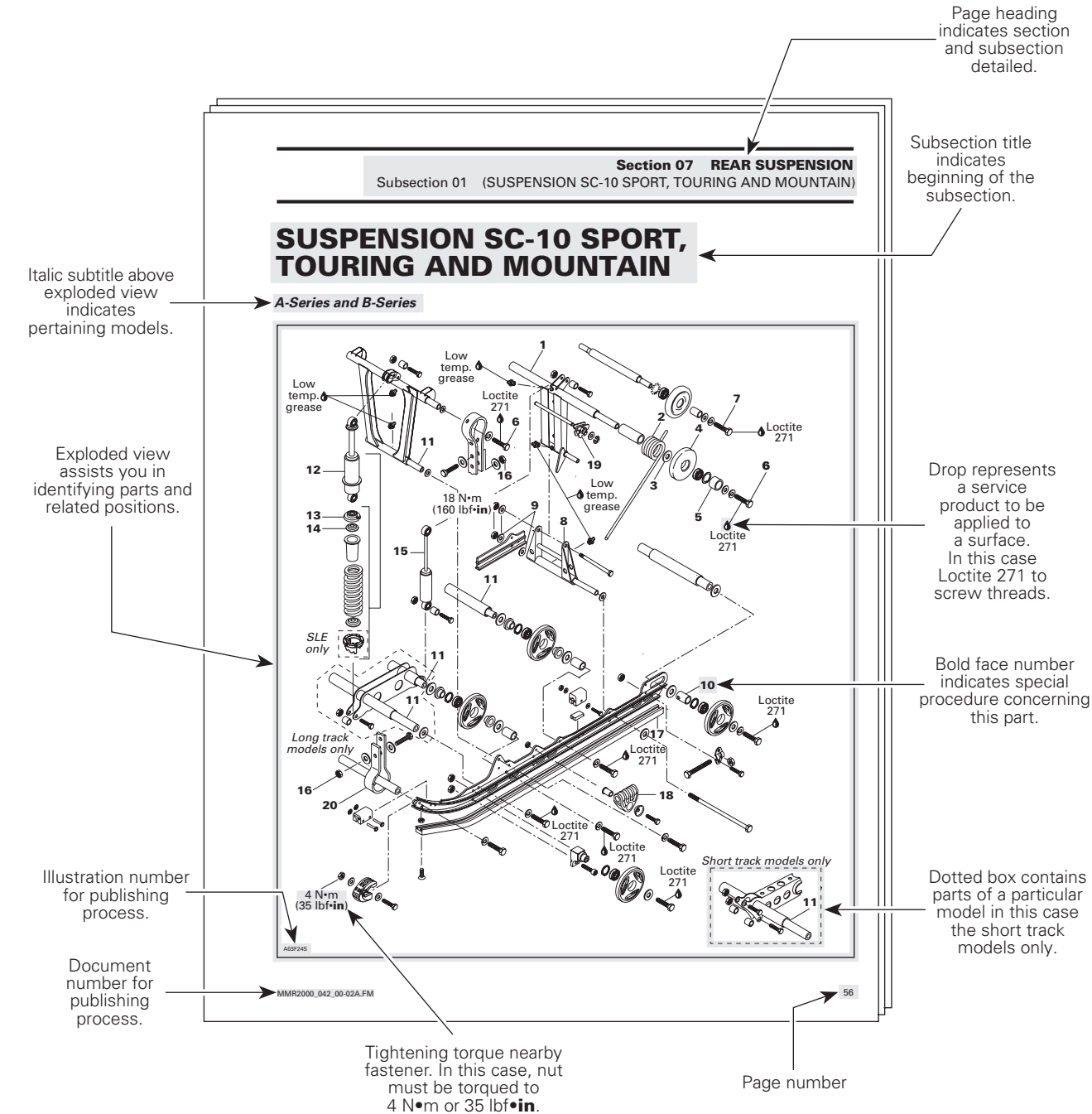

TYPICAL PAGE

Section 05 TRANSMISSION
 Subsection 03 (DRIVEN PULLEY)

Turn puller handle and sliding half at once to extract the bushing.

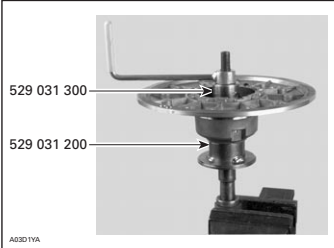

529 031 300

529 031 200

A0301YA

IMPORTANT: Large bushing retaining screws and washers must be removed before small bushing installation.
 Coat bushing outside diameter with Loctite 609 (P/N 413 703 100).
 Install bushing as following photo.

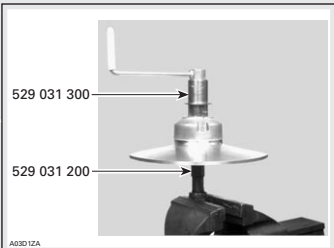

529 031 300

529 031 200

A0301ZA

ASSEMBLY

Came Slider Shoe

When replacing slider shoes **no. 4**, always install a new set (3 shoes) to maintain equal pressure on the cam.
 Assemble driven pulley components by reversing the disassembly procedure.

Cam

Coat cam **no. 18** interior with anti-seize lubricant.

MMR2000_042_00-02A.FM 57

INSTALLATION

Countershaft

CAUTION: Always apply anti-seize lubricant (P/N 413 701 000) on the countershaft before final pulley installation.

A-Series and B-Series Only

Should installation procedure be required, refer to BRAKE then look for Brake Disc and Countershaft Bearing Adjustment.
 Reinstall the pulley on the countershaft by reversing the removal procedure.

All Models

Check end play of driven pulley on countershaft by pushing pulley towards outer housing so that the inner shims (P/N 504 108 200) contact it. Measure end play at the mounting screw end between shim(s) and pulley. See illustration.

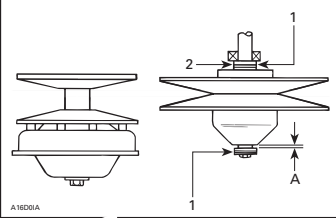

A1600A

TYPICAL — TOP VIEW

1. Shim (P/N 504 108 200) (as required)

2. Contact

A. 0 to 1 mm (0 to 3/64 in)

Torque retaining screw **no. 13** to 25 N•m (18 lbf•ft).

ADJUSTMENT

Refer to PULLEY DISTANCE AND ALIGNMENT to adjust pulley distance. Adjust drive belt height between pulley halves to obtain specified belt deflection.

Title indicates main procedure to be carried-out.

Italic bold face type setting indicates a particular procedure concerning a model.

Italic bold face setting in this case indicates that particular procedure for A and B-Series is finished, so from this point, all models are concerned.

"TYPICAL" caption indicates a general view which does not represent full detail. "TOP VIEW" caption helps you in understanding illustration.

Call-outs for above illustration.

Reference to look up a certain section and subsection. In this case it concerns pulleys adjustment.

Illustration always follows text to which it pertains.

Subtitle indicates a particular procedure for the named part.

Bold face number following part name refers to exploded view at beginning of subsection.

INTRODUCTION

GENERAL INFORMATION

The information and component/system descriptions contained in this manual are correct at time of publication. BRP however, maintains a policy of continuous improvement of its products without imposing upon itself any obligation to install them on products previously manufactured.

Due to late changes, it may have some differences between the manufactured product and the description and/or specifications in this document.

BRP reserves the right at any time to discontinue or change specifications, designs, features, models or equipment without incurring obligation.

ILLUSTRATIONS AND PROCEDURES

Illustrations and photos show the typical construction of the different assemblies and, in all cases, may not reproduce the full detail or exact shape of the parts shown. However, they represent parts which have the same or a similar function.

CAUTION: Most components of those vehicles are built with parts dimensioned in the metric system. Most fasteners are metric and must not be replaced by customary fasteners or vice-versa. Mismatched or incorrect fasteners could cause damage to the vehicle or possible personal injury.

As many of the procedures in this manual are inter-related, we suggest, that before undertaking any task, you read and thoroughly understand the entire section or subsection in which the procedure is contained.

A number of procedures throughout the book require the use of special tools. Before commencing any procedure, be sure that you have on hand all the tools required, or approved equivalents.

The use of RIGHT and LEFT indications in the text, always refers to driving position (when sitting on vehicle).

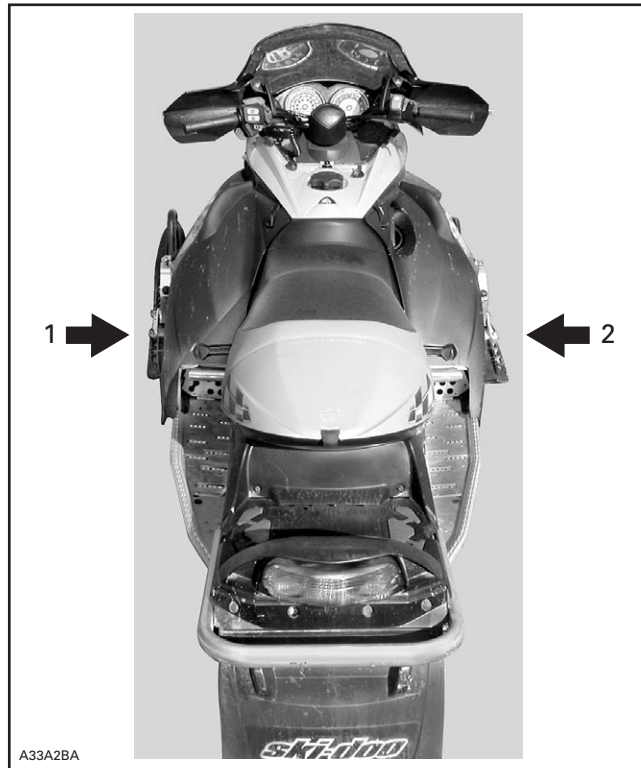

TYPICAL
1. Left
2. Right

SELF-LOCKING FASTENERS PROCEDURE

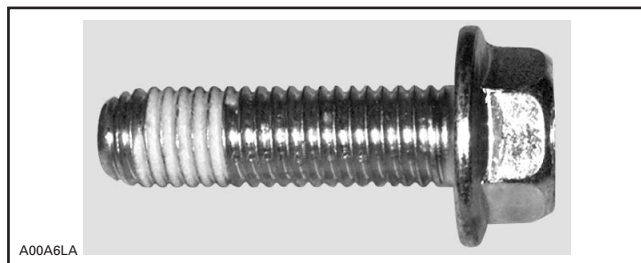

TYPICAL — SELF-LOCKING FASTENER

The following describes the most common application procedures when working with self-locking fasteners.

Use a metal brush or a tap to clean the hole properly then use a solvent (Methyl-Chloride), let act during 30 minutes and wipe off. The solvent utilization is to ensure the adhesive works properly.

LOCTITE APPLICATION PROCEDURE

The following describes the most common application procedures when working with Loctite products.

NOTE: Always use proper strength Loctite product as recommended in this shop manual.

THREADLOCKER

Uncovered Holes (bolts and nuts)

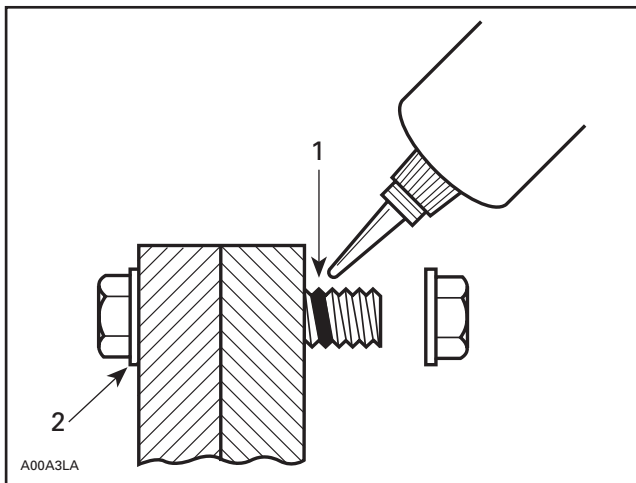

1. Apply here
2. Do not apply

- Clean threads (bolt and nut) with solvent.
- Apply Loctite Primer N (P/N 293 800 041) on threads and allow to dry.
- Choose proper strength Loctite threadlocker.
- Fit bolt in the hole.
- Apply a few drops of threadlocker at proposed tightened nut engagement area.
- Position nut and tighten as required.

Blind Holes

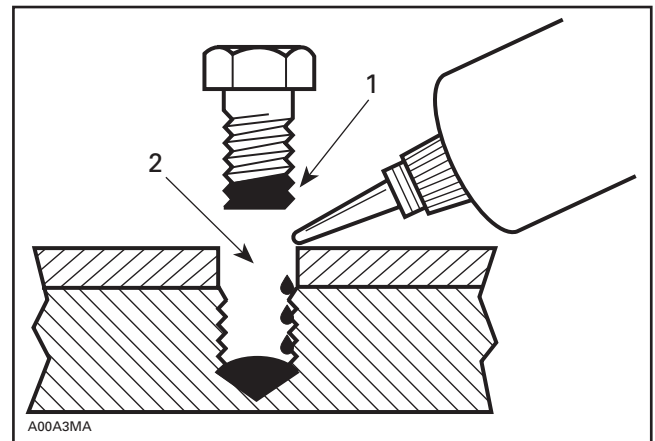

1. On threads
2. On threads and at the bottom of hole

- Clean threads (bolt and hole) with solvent.
- Apply Loctite Primer N (P/N 293 800 041) on threads (bolt and nut) and allow to dry for 30 seconds.
- Choose proper strength Loctite threadlocker.
- Apply several drops along the threaded hole and at the bottom of the hole.
- Apply several drops on bolt threads.
- Tighten as required.

Stud in Blind Holes

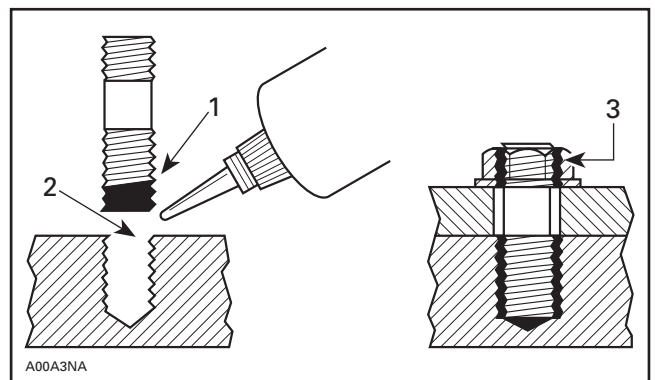

1. On threads
2. On threads and in the hole
3. Onto nut threads

- Clean threads (stud and hole) with solvent.
- Apply Loctite Primer N (P/N 293 800 041) on threads and allow to dry.
- Put several drops of proper strength Loctite threadlocker on female threads and in hole.

INTRODUCTION

- Apply several drops of proper strength Loctite on stud threads.
- Install stud.
- Install cover, etc.
- Apply drops of proper strength Loctite on uncovered threads.
- Tighten nuts as required.

Preassembled Parts

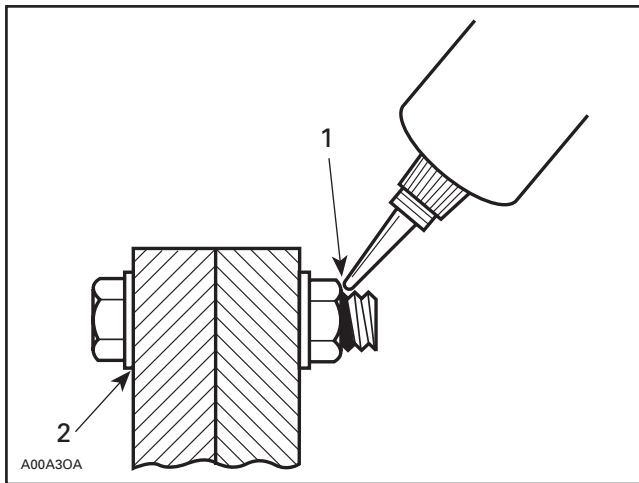

1. Apply here
2. Do not apply

- Clean bolts and nuts with solvent.
- Assemble components.
- Tighten nuts.
- Apply drops of proper strength Loctite on bolt/nut contact surfaces.
- Avoid touching metal with tip of flask.

NOTE: For preventive maintenance on existing equipment, retighten nuts and apply proper strength Loctite on bolt/nut contact surfaces.

Adjusting Screw

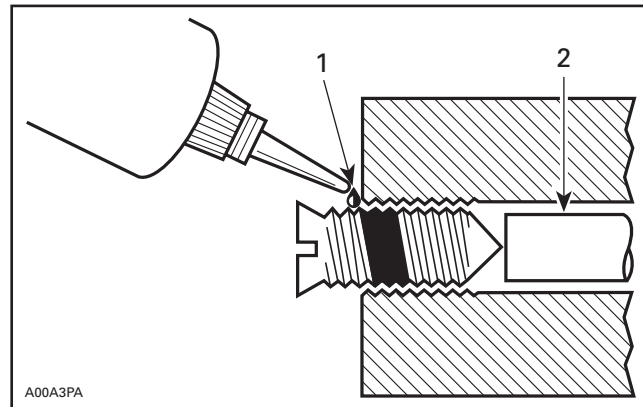

1. Apply here
2. Plunger

- Adjust screw to proper setting.
- Apply drops of proper strength Loctite threadlocker on screw/body contact surfaces.
- Avoid touching metal with tip of flask.

NOTE: If it is difficult to readjust, heat screw with a soldering iron (232°C (450°F)).

STRIPPED THREAD REPAIR

Stripped Threads

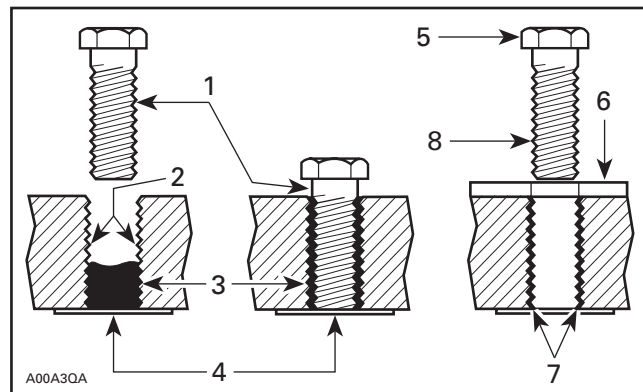

1. Release agent
2. Stripped threads
3. Form-A-Thread
4. Tape
5. Cleaned bolt
6. Plate
7. New threads
8. Threadlocker

Standard Thread Repair

- Follow instructions on Loctite FORM-A-THREAD 81668 package.

- If a plate is used to align bolt:
 - Apply release agent on mating surfaces.
 - Put waxed paper or similar film on the surfaces.
 - Twist bolt when inserting it to improve thread conformation.

NOTE: NOT intended for engine stud repairs.

Repair of Small Holes/Fine Threads

Option 1: Enlarge damaged hole, then follow STANDARD THREAD REPAIR procedure.

Option 2: Apply FORM-A-THREAD on the screw and insert in damaged hole.

Permanent Stud Installation (light duty)

- Use a stud or thread on desired length.
- DO NOT apply release agent on stud.
- Do a STANDARD THREAD REPAIR.
- Allow to cure for 30 minutes.
- Assemble.

GASKET COMPOUND

All Parts

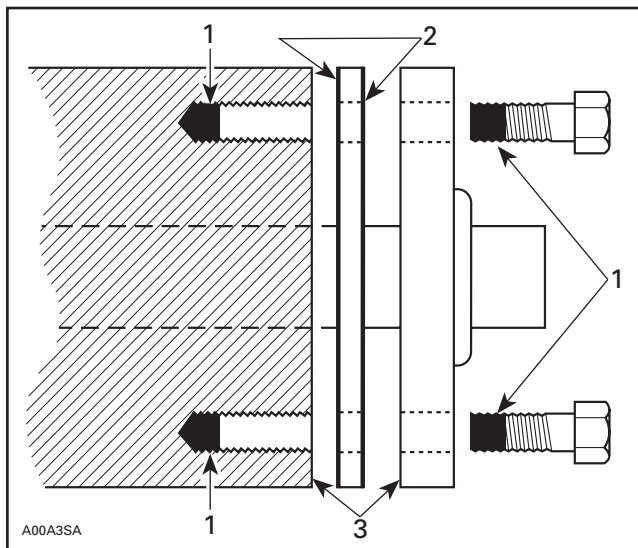

1. Proper strength Loctite
2. Loctite Primer N (P/N 413 708 100) and Gasket Eliminator 515 (P/N 413 702 700) on both sides of gasket
3. Loctite Primer N only

- Remove old gasket and other contaminants with Loctite Chisel remover (P/N 413 708 500). Use a mechanical mean if necessary.

NOTE: Avoid grinding.

- Clean both mating surfaces with solvent.

- Spray Loctite Primer N on both mating surfaces and on both sides of gasket. Allow to dry 1 or 2 minutes.
- Apply GASKET ELIMINATOR 515 (P/N 413 702 700) on both sides of gasket, using a clean applicator.
- Place gasket on mating surfaces and assemble immediately.

NOTE: If the cover is bolted to blind holes (above), apply proper strength Loctite in the hole and on threads. Tighten.

If holes are sunken, apply proper strength Loctite on bolt threads.

- Tighten as usual.

MOUNTING ON SHAFT

Mounting with a Press

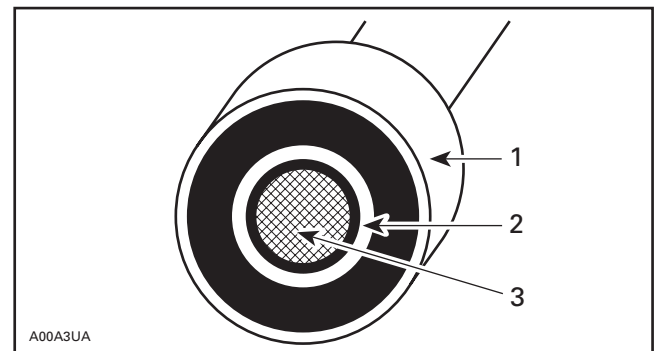

1. Bearing
2. Proper strength Loctite
3. Shaft

Standard

- Clean shaft external part and element internal part.
- Apply a strip of proper strength Loctite on shaft circumference at insert or engagement point.

NOTE: Retaining compound is always forced out when applied on shaft.

- DO NOT use anti-seize Loctite or any similar product.
- No curing period is required.

Mounting in Tandem

- Apply retaining compound on internal element bore.
- Continue to assemble as shown above.

INTRODUCTION

CASE-IN COMPONENTS

Metallic Gaskets

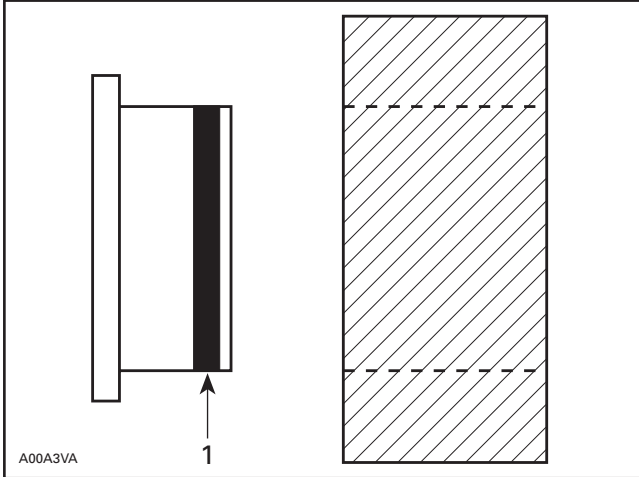

1. *Proper strength Loctite*

- Clean inner housing diameter and outer gasket diameter.
- Spray housing and gasket with Loctite Primer N (P/N 293 800 041).
- Apply a strip of proper strength Loctite on leading edge of outer metallic gasket diameter.

NOTE: Any Loctite product can be used here. A low strength liquid is recommended as normal strength and gap are required.

- Install according to standard procedure.
- Wipe off surplus.
- Allow it to cure for 30 minutes.

NOTE: Normally used on worn-out housings to prevent leaking or sliding.

It is generally not necessary to remove gasket compound applied on outer gasket diameter.

TIGHTENING TORQUE

Tighten fasteners to torque mentioned in exploded views and/or text. When they are not specified, refer to following table. The table also gives the metric conversion.

⚠ WARNING

Torque wrench tightening specifications must strictly be adhered to. Locking devices (ex.: locking tabs, elastic stop nuts, self-locking fasteners, etc.) must be installed or replaced with new ones, where specified. If the efficiency of a locking device is impaired, it must be renewed.

In order to avoid a poor assembling, tighten screws, bolts or nuts in accordance with the following procedure:







- Manually screw all screws, bolts and/or nuts.
- Apply the half of the recommended torque value.

CAUTION: Be sure to use proper tightening torque for the proper strength grade.

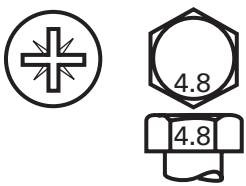
NOTE: When possible, always apply torque on the nut.

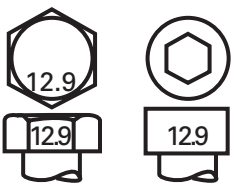
- Torque at the recommended torque value.

NOTE: Always torque screws, bolts and/or nuts in a criss-cross sequence.

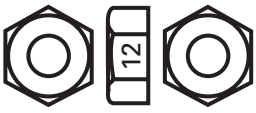
Property class and head markings	<p>4.8</p> 	<p>8.8 9.8</p> 	<p>10.9</p> 	<p>12.9</p> 
Property class and nut markings	<p>5</p> 	<p>10</p> 	<p>10</p> 	<p>12</p> 

A00A8BS

FASTENER SIZE	FASTENER GRADE/TORQUE			
	5.8 Grade	8.8 Grade	10.9 Grade	12.9 Grade
M4	1.5 – 2 N•m (13 – 18 lbf•in)	2.5 – 3 N•m (22 – 27 lbf•in)	3.5 – 4 N•m (31 – 35 lbf•in)	4 – 5 N•m (35 – 44 lbf•in)
M5	3 – 3.5 N•m (27 – 31 lbf•in)	4.5 – 5.5 N•m (40 – 47 lbf•in)	7 – 8.5 N•m (62 – 75 lbf•in)	8 – 10 N•m (71 – 89 lbf•in)
M6	6.5 – 8.5 N•m (58 – 75 lbf•in)	8 – 12 N•m (71 – 106 lbf•in)	10.5 – 15 N•m (93 – 133 lbf•in)	16 N•m (142 lbf•in)
M8	15 N•m (11 lbf•ft)	24.5 N•m (18 lbf•ft)	31.5 N•m (23 lbf•ft)	40 N•m (30 lbf•ft)
M10	29 N•m (21 lbf•ft)	48 N•m (35 lbf•ft)	61 N•m (45 lbf•ft)	72.5 N•m (53 lbf•ft)
M12	52 N•m (38 lbf•ft)	85 N•m (63 lbf•ft)	105 N•m (77 lbf•ft)	127.5 N•m (94 lbf•ft)
M14	85 N•m (63 lbf•ft)	135 N•m (100 lbf•ft)	170 N•m (125 lbf•ft)	200 N•m (148 lbf•ft)

Section 01 MAINTENANCE
Subsection 01 (MAINTENANCE CHART)

MAINTENANCE CHART

A: ADJUST I: INSPECT (clean, inspect, repair, adjust) L: LUBRICATE R: REPLACE C: CLEAN T: PROCEED WITH TASK	10-HOUR OR 500 KM (300 mi) INSPECTION (to be performed by dealer)							
	WEEKLY OR EVERY 240 KM (150 mi)			MONTHLY OR EVERY 800 KM (500 mi)		ONCE A YEAR OR EVERY 3200 KM (2000 mi)		
PART/TASK						6000 KM (3700 mi)		REFER TO SECTION(S) AND SUBSECTION(S)
	STORAGE (to be performed by dealer)							
	PRESEASON PREPARATION (to be performed by dealer)							
ENGINE								
Rewind starter and rope						I,L	I	03-09
Engine motor mounts	I			I		I		Section 03, see the appropriate subsection
Exhaust system	I		I			I		03-02
Engine lubrication						L		01-02
Cooling system	I			I			I	03-08
Coolant	I					R		03-08
Crankshaft PTO Seal ⁽⁴⁾						I		Section 03, see the appropriate subsection
RAVE valves ⁽⁴⁾				C				03-05
RAVE valves solenoid (SDI and Power Tek)				I				03-05
Injection oil filter			I			R		03-10
Oil injection pump	A			A			A	03-10
FUEL SYSTEM								
Add fuel stabilizer						T		01-02
Fuel filter							R	01-03
Fuel lines, fuel rail and connections	I						I	Section 03, 05-03 or 06-03
Carburetor	A			A			A,C	04-02
Throttle cable	I			I			I	04-02
Air filter			C				C	01-03
Injection oil						T		01-02
Throttle body (SDI) ⁽⁴⁾							C	05-03 or 06-03
DRIVE SYSTEM								
Drive belt	I	I					I	08-01
Drive and driven pulley	I		I	C		I	C	08-02 and 08-03
Tightening torque of drive pulley screw	I			I			I	08-02
Brake fluid	I	I				R	I	08-05
Brake hose, pads and disk	I	I					I	08-05
Drive chain tension	A		A			A		08-06
Chaincase oil	I		I			R	I	08-06
Drive axle end bearing ⁽²⁾	L		L			L		08-07

Section 01 MAINTENANCE

Subsection 01 (MAINTENANCE CHART)

PART/TASK	10-HOUR OR 500 KM (300 mi) INSPECTION (to be performed by dealer)							REFER TO SECTION(S) AND SUBSECTION(S)	
	WEEKLY OR EVERY 240 KM (150 mi)			MONTHLY OR EVERY 800 KM (500 mi)		ONCE A YEAR OR EVERY 3200 KM (2000 mi)			
	6000 KM (3700 mi)		STORAGE (to be performed by dealer)				PRESEASON PREPARATION (to be performed by dealer)		
A: ADJUST I: INSPECT (clean, inspect, repair, adjust) L: LUBRICATE R: REPLACE C: CLEAN T: PROCEED WITH TASK									
Countershaft	L		L			L		08-07	
Track	I		I			I		08-08	
Track tension and alignment	A	AS REQUIRED							08-08
STEERING/FRONT SUSPENSION									
Steering and front suspension mechanism ⁽²⁾	I,L		I	L		I,L		10-01 and 10-02	
Wear and condition of skis and runners	I	I				I		10-02	
SUSPENSION									
Suspension adjustments	A	AS REQUIRED							Section 09, see the appropriate subsection
Suspension ⁽²⁾	I		I,L			I,L			
Suspension stopper strap				I		I			
ELECTRICAL									
EMS fault codes ⁽⁴⁾	I					I		05-03 or 06-03	
Spark plugs ^{(1) (4)}	I		I				R	07-01	
Battery (if so equipped)	I		I			I	I	07-02	
Wiring harnesses, cables and lines ⁽⁴⁾	I		I			I		11-01	
Operation of lighting system (HI/LO beam, brake light, etc.) test operation of engine cut-out switch and tether cut-out switch	I	I				I		<i>Operator's Guide</i>	
VEHICLE									
Headlamp beam aiming				A			A	11-01	
Rags in air intake and exhaust system						T	T	01-02 and 01-03	
Engine compartment	C		C			C		01-02	
Vehicle cleaning and protection	C		C			C		01-02	

- (1) TO BE PERFORMED BY AN AUTHORIZED SKI-DOO DEALER.
- (2) Lubricate whenever the vehicle is used in wet conditions (wet snow, rain, puddles).
- (3) Before installing new spark plugs at pre-season preparation, it is suggested to burn excess storage oil by starting the engine with the old spark plugs. Only perform this operation in a well-ventilated area.
- (4) Emission-related

STORAGE

SERVICE TOOLS

Description	Part Number	Page
cleat remover.....	529 028 700	5
narrow-cleat installer	529 028 800	5

SERVICE PRODUCTS

Description	Part Number	Page
anti-seize lubricant.....	293 800 070	5
BOMBARDIER LUBE	293 600 016	4, 6
BOMBARDIER scratch remover kit	861 774 800	6
fuel stabilizer.....	413 408 600	4
heavy duty cleaner (4 L).....	293 110 002	6
heavy duty cleaner (spray can 400 g)	293 110 001	6
storage oil (Canada)	413 711 600	4
storage oil (USA).....	413 711 900	4
suspension synthetic grease	293 550 033	5
vinyl & plastic cleaner (6 x 1 L)	413 711 200	6

GENERAL

Proper snowmobile storage is a necessity during the summer months or when a vehicle is not being used for more than one month.

Refer to storage column from MAINTENANCE CHART jointly with the present storage procedure in order to cover each and every aspect of the snowmobile storage procedure. Any worn, broken or damaged parts should be replaced.

 WARNING

Unless otherwise specified, engine should be turned off for storage procedure.

ENGINE

Rewind Starter and Rope

For inspection, cleaning and lubrication, refer to ENGINE section.

Engine Motor Mounts

Check if engine support is cracked, bent or otherwise damaged. Replace if necessary.

Check rubber mounts on engine support. Replace them if brittle, cracked or otherwise damaged.

Exhaust System

Check and replace if necessary:

- tuned pipe shield for damages
- tuned pipe ends for cracks or damages
- manifold for cracks or damages.

Engine Lubrication

NOTE: Be sure to add fuel stabilizer before starting the engine.

Engine internal parts must be lubricated to protect them from possible rust formation during the storage period.

Section 01 MAINTENANCE

Subsection 02 (STORAGE)

Proceed as follows:

Start the engine and allow it to run at idle speed until the engine reaches its operating temperature.

WARNING

Ensure the track is free of particles which could be thrown out while it is rotating. Keep hands, tools, feet and clothing clear of track. Ensure no one is standing in close proximity to the vehicle.

Stop the engine.

Remove air silencer to spray storage oil into each carburetor/throttle body.

Restart engine and run at idle speed.

Inject storage oil until the engine stalls or until a sufficient quantity of oil has entered the engine (approximately half a can).

With the engine stopped, remove the spark plug and spray storage oil (Canada) (P/N 413 711 600) or storage oil (USA) (P/N 413 711 900) into each cylinder.

Crank slowly 2 or 3 revolutions to lubricate cylinders.

Reinstall the spark plugs and air silencer.

WARNING

This procedure must only be performed in a well-ventilated area. Do not run engine during storage period.

Cooling System

For coolant replacement on liquid cooled models, refer to ENGINE section.

Crankshaft PTO Seal

Make sure there is no grease coming out from crankshaft PTO seal, if so replace seal, refer to ENGINE section.

Injection Oil Filter

Replace injection oil filter, refer to ENGINE section.

Rags in Air Intake and Exhaust System

Block air intake hole and exhaust system hole using clean rags.

FUEL SYSTEM

Fuel Stabilizer

It is critical to use the fuel stabilizer (P/N 413 408 600) (250 mL) to prevent fuel deterioration, gum formation and fuel system components corrosion. Follow manufacturer's instructions for proper use.

Pour fuel stabilizer in fuel tank prior to starting engine for internal parts lubrication so that stabilizer flows everywhere in fuel system. Fill up fuel tank completely. Ensure there is no water inside fuel tank.

CAUTION: Should any water be trapped inside fuel tank, severe internal damage will occur to the fuel injection system (if so equipped).

Do not drain fuel system.

CAUTION: Fuel stabilizer should be added prior to engine lubrication to ensure carburetor protection against varnish deposit.

WARNING

Fuel is flammable and explosive under certain conditions. Always work in a well ventilated area. Do not smoke or allow open flames or sparks in the vicinity. Fuel tank may be pressurized, slowly turn cap when opening. Never use an open flame to check fuel level. When fueling, keep vehicle level. Do not overfill or top off the fuel tank and leave vehicle in the sun. As temperature increases, fuel expands and might overflow. Always wipe off any fuel spillage from the vehicle. Periodically inspect fuel system.

DRIVE SYSTEM

Drive and Driven Pulley

After inspection and interior cleaning of pulleys, spray BOMBARDIER LUBE (P/N 293 600 016) on sheaves. Do not reinstall drive belt.

Brake Fluid

Replace brake fluid, refer to DRIVE SYSTEM section.

Drive Chain Tension

Check drive chain tension and adjust if necessary, refer to DRIVE SYSTEM section.

Chaincase Oil

Replace chaincase oil, refer to DRIVE SYSTEM section.

Drive Axle End Bearing

Lubricate end housing bearing with suspension synthetic grease (P/N 293 550 033). Continue lubricating until grease flows out of the pilot hole on speedometer sensor.

Countershaft

Driven pulley and brake disc must be floating on the countershaft for efficient operation. Lubricate with anti-seize lubricant (P/N 293 800 070).

CAUTION: Do not lubricate excessively as lubricant could contact and soil brake pads and/or drive belt.

Track

Visually inspect track for:

- cuts and abnormal wear
- broken rods
- broken or missing track cleats.

If track is damaged or rods are broken, replace track, refer to DRIVE SYSTEM section.

For damaged or missing cleats, replace by new ones, using cleat remover (P/N 529 028 700). Use narrow-cleat installer (P/N 529 028 800).

STEERING/FRONT SUSPENSION

Steering and Front Suspension Mechanism Lubrication

Lubricate the steering mechanism if needed. **Inspect all components for tightness.**

Wear and Condition of Skis and Runners

Inspect skis and runners for wear, deterioration or damage, replace if necessary.

SUSPENSION

Rear Suspension Lubrication

Inspect rear suspension components for wear, deterioration or damage, replace defective parts if necessary.

Lubricate front and rear arms at grease fittings using suspension synthetic grease (P/N 293 550 033).

Suspension Stopper Strap

Inspect strap for wear or cracks, bolt and nut for tightness. If loose, inspect hole for deformation. Replace if necessary.

ELECTRICAL

Battery (if so equipped)

Remove battery, clean its tray and close area with water and baking soda.

Visually inspect battery casing for cracks, leaks or other possible damage. Discoloration, warping or raised top, indicates that battery has overheated or been overcharged. If casing is damaged, replace battery.

Charge battery as explained in ELECTRICAL section.

Wiring Harnesses, Cables and Lines

Inspect for wear, deterioration or damage, replace defective parts if necessary.

VEHICLE

Engine Compartment

Keep clean of grass, twigs, cloth, etc. These are combustible under certain conditions.

Vehicle Cleaning

To facilitate the inspection and ensure adequate lubrication of components, it is recommended to clean the entire vehicle.

Remove any dirt or rust.

To clean the entire vehicle, use only flannel cloths or equivalent.

CAUTION: It is necessary to use flannel cloths or equivalent on windshield and hood to avoid further damaging surfaces to clean.

Section 01 MAINTENANCE

Subsection 02 (STORAGE)

To clean the entire vehicle, including bottom pan and metallic parts use heavy duty cleaner (spray can 400 g) (P/N 293 110 001) or heavy duty cleaner (4 L) (P/N 293 110 002).

CAUTION: Do not use Heavy duty cleaner on decals or vinyl.

For vinyl and plastic parts use vinyl & plastic cleaner (6 x 1 L) (P/N 413 711 200).

To remove scratches on windshield or hood use BOMBARDIER scratch remover kit (P/N 861 774 800).

CAUTION: Never clean plastic parts or hood with strong detergent, degreasing agent, paint thinner, acetone, products containing chlorine, etc.

Inspect the hood and repair any damage.

Touch up all metal spots with touch-up paint where paint has been scratched off.

Spray all bare metal parts including shock chromed rods with BOMBARDIER LUBE (P/N 293 600 016).

Wax the hood and the painted portion of the frame for better protection. Use a non-abrasive wax such as silicone wax.

NOTE: Apply non-abrasive wax on glossy finish only.

Vehicle Protection

Protect the vehicle with a cover to prevent dust accumulation during storage.

CAUTION: The snowmobile has to be stored in a cool and dry place and covered with an opaque but ventilated tarpaulin. This will prevent sun rays and grime from affecting plastic components and vehicle finish.

Lift rear of vehicle until track is clear of the ground. Install on a snowmobile mechanical stand.

NOTE: Do not release track tension.

PRESEASON PREPARATION

SERVICE PRODUCTS

Description	Part Number	Page
pulley flange cleaner.....	413 711 809	8
XP-S chaincase oil.....	413 801 900	8
XP-S synthetic chaincase oil.....	413 803 300	8

Proper vehicle preparation is necessary after the summer months or when a vehicle has not been used for more than one month.

Refer to preseason preparation column from MAINTENANCE CHART jointly with the present preseason preparation procedure in order to cover each and every aspect of the snowmobile preseason preparation procedure.

Any worn, broken or damaged parts found during the storage procedure should have been replaced. If not, proceed with the replacement.

⚠ WARNING

Unless otherwise specified, engine should be turned off for preparation procedure.

ENGINE

Rags in Air Intake and Exhaust System

Remove rags that were installed during STORAGE preparation.

Rewind Starter and Rope

Check if rope is fraying, replace if so. When pulling starter grip, it must return freely. If not, check for damaged parts or lack of lubrication. Replace parts or lubricate accordingly.

Cooling System

Fan Cooled

Inspect fan drive belt, adjust or replace if required.

Liquid Cooled

Inspect cooling system for leaks, to perform a cooling system leak test, refer to ENGINE section and the appropriate subsection.

Check coolant level in coolant reservoir. Add coolant if necessary.

If engine is cold, refill up to 15 mm (5/8 in) over COLD level line.

If engine is hot, refill up to 25 mm (1 in) over COLD level line.

Oil Injection Pump

Make sure oil injection pump is properly adjusted, refer to ENGINE section and the appropriate subsection.

FUEL SYSTEM

Fuel Filter

Replace fuel filter, refer to FUEL SYSTEM section and the appropriate subsection.

Fuel Lines, Fuel Rails and Connections

Inspect fuel system for leaks, to perform a fuel system pressurization, refer to FUEL SYSTEM section and the appropriate subsection.

Carburetor (if so equipped)

Disassemble carburetors in order to clean all internal parts. Do not hesitate to replace any jets having gum or varnish on their surfaces.

Make sure carburetors are properly adjusted, refer to FUEL SYSTEM section and the appropriate subsection.

Throttle Cable

Make sure that throttle cable operate freely, replace if necessary, refer to FUEL SYSTEM and the appropriate subsection.

Section 01 MAINTENANCE

Subsection 03 (PRESEASON PREPARATION)

Air Filter

Check that inside of air silencer is clean and dry then properly reinstall the filter.

CAUTION: These snowmobiles have been calibrated with the filter installed. Operating the snowmobile without it, may cause engine damage.

Throttle Body (SDI)

Remove the throttle body from vehicle.

Using the pulley flange cleaner (P/N 413 711 809), remove the dirt ejected by the drive belt from the throttle plate and from both throttle body bores. After throttle body installation, adjust throttle and injection oil cables.

Injection Oil

Add 500 mL (17 U.S. oz) of recommended injection oil to the first full filled fuel tank.

DRIVE SYSTEM

Drive Belt

Inspect belt for cracks, fraying or abnormal wear. Replace if necessary.

Make sure to install the proper belt with arrow printed on belt pointing front of vehicle.

Drive and Driven Pulley

Clean drive and driven pulleys sheaves with pulley flange cleaner (P/N 413 711 809).

Retorque if necessary drive pulley screw to 90 to 100 N•m (66 to 74 lbf•ft).

Brake Fluid

Check brake fluid in reservoir for proper level. Add fluid (DOT 4) as required.

CAUTION: Use only (DOT 4) brake fluid from a sealed container. Do not store or use a started bottle of brake fluid.

Brake Hose, Pads and Disk

Inspect brake hose for wear, deterioration or damage, replace if necessary.

Inspect brake pads for proper thickness. Refer to DRIVETRAIN section and the appropriate subsection.

Remove any rust built-up on braking surfaces. Clean brake disk braking surfaces with pulley flange cleaner (P/N 413 711 809).

Chaincase Oil

Check chaincase oil for proper level. Add recommended chaincase oil as required.

MODELS	CHAINCASE OIL
Fan Cooled	XP-S chaincase oil (P/N 413 801 900)
Liquid Cooled	XP-S synthetic chaincase oil (P/N 413 803 300)

Track Tension and Alignment

Verify track tension and alignment, refer to DRIVE SYSTEM section and the appropriate subsection.

NOTE: Track tension and alignment are interrelated. Do not adjust one without checking the other. Track tension procedure must be carried out prior to track alignment.

ELECTRICAL SYSTEM

Battery (if so equipped)

Verify that battery is fully charged, if not, refer to the appropriate charging procedure in ELECTRICAL SYSTEM section and the appropriate subsection.

WARNING

Always wear safety glasses and charge in a ventilated area. Never charge or boost battery while installed on vehicle. Do not open the sealed caps during charging. Do not place battery near open flame.

Spark Plugs

Once preseason preparation is done, start engine with the old spark plug(s) to burn excess storage oil. Then, install new properly gapped spark plug(s).

VEHICLE

Headlamp Beam Aiming

Verify beam aiming and adjust if necessary, refer to ELECTRICAL SYSTEM section and the appropriate subsection.

ENGINE

The following chart is provided to help diagnose the probable source of troubles. It should be used as a guideline. Some causes or corrections may not apply to a specific model.

NOTE: For engine management system troubleshooting (SDI and Power Tek engines), refer to appropriate subsection.

SYMPTOM	ENGINE BACKFIRES.
CONDITION	NORMAL USE.
TEST/INSPECTION	<p>1. Check spark plugs. a. Carbon accumulation caused by defective spark plug(s). <i>Clean carbon accumulation from piston and cylinder head and install dry properly gapped spark plug(s).</i></p> <p>2. Check ignition timing. a. Timing is too advanced. <i>Set timing according to specifications (refer to TECHNICAL DATA).</i></p> <p>3. Check for erratic sparks. a. Poor electrical connections. <i>Repair.</i> b. Faulty stator. <i>Replace defective parts.</i></p> <p>4. Check carburetor. a. Fuel passages obstructed. <i>Clean carburetor and install new filter(s).</i> b. Fuel level too low. <i>Adjust float level according to specifications.</i></p> <p>5. Check cooling system. a. Low antifreeze level. <i>Adjust antifreeze level. Proceed with a leakage test (refer to COOLING SYSTEM) and repair as required.</i> b. Defective tank cap. <i>Replace cap.</i> c. Defective thermostat. <i>Replace thermostat.</i> d. Air in system. <i>Bleed system.</i></p>

SYMPTOM	ENGINE SUDDENLY TURNS OFF AT HIGH RPM AND/OR WITH LIGHT LOAD.
CONDITION	NORMAL USE.
TEST/INSPECTION	<p>1. Check spark plugs. a. Non-resistor type spark plugs installed.</p> <p>2. Check that all 3 ground wires are well connected. a. Loose or corroded ground.</p>

Section 02 TROUBLESHOOTING

Subsection 01 (ENGINE)

SYMPTOM	ENGINE SUDDENLY TURNS OFF.
CONDITION	NORMAL USE.
TEST/INSPECTION	<p>1. Perform engine leak test. Refer to LEAK TEST. Check possible piston seizure.</p> <p>a. Damaged gasket and/or seal. <i>Replace defective parts.</i></p> <p>2. "Four-corner" seizure of piston(s).</p> <p>a. High acceleration when engine is cold. Piston expands faster than cylinder. <i>Replace piston(s). Ask driver to refer to the WARM-UP PROCEDURE in the Operator's Guide.</i></p> <p>3. Piston(s) seizure on exhaust side (color on piston dome is correct).</p> <p>a. Kinked fuel tank vent tube. <i>Relocate fuel tank vent tube.</i></p> <p>b. Leaks at fuel line connections or damaged fuel lines. <i>Replace defective lines.</i></p> <p>c. Fuel does not flow through carburetor(s) (foreign particles in needle area and/or varnish formation in carburetor(s)). <i>Clean carburetor(s) and install new filter(s).</i></p> <p>d. Spark plug heat range is too warm. <i>Install spark plugs with appropriate heat range (refer to TECHNICAL DATA).</i></p> <p>e. Improper ignition timing. <i>Adjust according to specifications (refer to TECHNICAL DATA).</i></p> <p>f. Restriction in exhaust system. <i>Replace.</i></p> <p>g. Compression ratio is too high. <i>Install genuine parts.</i></p> <p>h. Too low fuel octane number. <i>Use proper fuel octane number.</i></p> <p>i. Carburetor calibration is too lean. <i>Adjust according to specifications (refer to TECHNICAL DATA).</i></p> <p>j. Improper reed valve adjustment or damage. <i>Adjust according to specifications (refer to appropriate ENGINE subsection) and/or install BRP's recommended reed valve.</i></p> <p>k. Poor quality oil. <i>Use XP-S injection oil.</i></p> <p>l. Leaks at air intake silencer. <i>Replace air intake silencer grommets.</i></p> <p>m. Excessive wear of piston rings. <i>Replace piston rings.</i></p>

Section 02 TROUBLESHOOTING
Subsection 01 (ENGINE)

SYMPTOM	ENGINE SUDDENLY TURNS OFF.
CONDITION	NORMAL USE.
TEST/INSPECTION	<p>4. Melted and/or perforated piston dome; melted section at ring end gap. a. When piston reaches TDC, mixture is ignited by heated areas in combustion chamber. This is due to an incomplete combustion of a poor quality oil. <i>Clean residue accumulation in combustion chamber and replace piston(s). Use XP-S injection oil.</i> b. Spark plug heat range is too high. <i>Install recommended dry properly gapped spark plugs (refer to TECHNICAL DATA).</i> c. Ignition timing is too advanced. <i>Adjust according to specifications (refer to TECHNICAL DATA).</i> d. Inadequate fuel quality. <i>Use appropriate fuel.</i> e. Carburetion is too lean. <i>Adjust according to specifications (refer to TECHNICAL DATA).</i></p> <p>5. Seized piston all around the circumference (dry surface). a. Lack of oil, damaged oil line or defective injection pump. <i>Replace defective part(s).</i></p> <p>6. Grooves on intake side of piston only. a. Oil film eliminated by water (snow infiltration in engine). This can also be caused by running engine on choke for too long. Excessive fuel will remove the oil film on the piston and make marks. <i>Replace piston(s) and check if intake system leaks.</i></p> <p>7. Piston color is dark due to seizure on intake and exhaust sides. a. Cooling system leaks and lowers coolant level. <i>Proceed with a leakage test (refer to COOLING SYSTEM) and repair as required. Add coolant in cooling system until appropriate level is reached.</i> b. Accumulation of foreign particles in needle valve and/or main jet area. <i>Clean carburetor(s).</i></p> <p>8. Cracked or broken piston(s). a. Cracked or broken piston(s) due to excessive piston/cylinder clearance or engine over-revving. <i>Replace piston(s). Check piston/cylinder clearance (refer to TOP END). Adjust drive pulley according to specifications (refer to TECHNICAL DATA) and/or clean pulley sheaves if they are contaminated with greasy particles.</i></p> <p>9. DPM manifold air vent is obstructed. a. Carburetion is too lean. <i>Ensure proper air vent.</i></p>

SYMPTOM	PISTON RING AND CYLINDER SURFACES ARE SCRATCHED.
CONDITION	NORMAL USE.
TEST/INSPECTION	<p>1. Check oil quality. a. Poor quality oil. <i>Use XP-S injection oil.</i></p> <p>2. Check injection pump and its hoses. a. Inadequate injection pump adjustment and/or defective hoses. <i>Adjust pump according to specifications (refer to ENGINE) and/or replace hoses.</i></p>

Section 02 TROUBLESHOOTING

Subsection 01 (ENGINE)

SYMPTOM	ENGINE DOES NOT OFFER MAXIMUM POWER AND/OR DOES NOT REACH MAXIMUM OPERATING RPM.
CONDITION	NORMAL USE.
TEST/INSPECTION	<p>1. Check spark plug condition and gap. a. Fouled spark plugs or wrong spark plug gap. <i>Replace or readjust gap.</i></p> <p>2. Check if there is water in fuel. a. There is water in fuel. <i>Drain fuel system, then fill with appropriate fuel.</i></p> <p>RAVE Equipped Engines</p> <p>3. Check proper operation of RAVE valves. (Refer to ENGINE EQUIPPED WITH RAVE VALVE DOES NOT REACH ITS FULL OPERATING RPM (500 TO 1000 RPM LOWER). <i>Repair.</i></p> <p>4. Check items listed in ENGINE RUNS OUT OF FUEL (refer to FUEL AND OIL SYSTEMS subsection).</p> <p>5. Check carburetor adjustments and cleanliness. a. Inadequate carburetor adjustments or dirt accumulation. <i>Adjust according to specifications (refer to TECHNICAL DATA) or clean.</i></p> <p>6. Check drive belt. a. Worn belt. <i>Replace belt if width is 3 mm (1/8 in) less than nominal dimension (refer to TECHNICAL DATA).</i></p> <p>7. Check track adjustment. a. Too much tension and/or improper alignment. <i>Align track and adjust its tension to specifications (refer to TECHNICAL DATA).</i></p> <p>8. Check drive pulley. a. Improper calibration screw adjustments (TRA pulley) and/or worn bushing(s). <i>Adjust according to specifications (refer to TECHNICAL DATA) and/or replace bushing(s).</i></p> <p>9. Check driven pulley. a. Worn bushing and/or spring tension. <i>Replace spring and/or adjust its tension according to specifications (refer to TECHNICAL DATA).</i></p> <p>10. Check exhaust system. a. Restriction or exhaust system leakage. <i>Replace or reseal with Ultra Copper.</i></p> <p>11. Check ignition timing. a. Decrease in power due to delayed ignition. <i>Adjust according to specifications (refer to TECHNICAL DATA).</i></p> <p>12. Check engine compression. a. Worn piston(s) and ring(s). <i>Replace (refer to TECHNICAL DATA for specifications).</i></p> <p>13. Check engine cooling system. a. Coolant level is low, cap fails to pressurize system or air circulates through lines. <i>Adjust level, replace cap or bleed cooling system.</i></p> <p>14. Check reed valve. a. Improper tightness and/or opening. <i>Replace or adjust. (Refer to proper ENGINE subsection).</i></p>

Section 02 TROUBLESHOOTING
Subsection 01 (ENGINE)

SYMPTOM	ENGINE DETONATION AT MAXIMUM RPM.
CONDITION	NORMAL USE.
TEST/INSPECTION	<p>1. Check which type of fuel is used. a. Octane number is too low and/or alcohol level is too high. <i>Use recommended fuel type.</i></p> <p>2. Check spark plug type. a. Improper spark plug heat range. <i>Install recommended spark plugs (refer to TECHNICAL DATA).</i></p> <p>3. Check exhaust system. a. Too much restriction. <i>Replace.</i></p> <p>4. Check ignition timing. a. Timing is too advanced. <i>Adjust according to specifications (refer to TECHNICAL DATA).</i></p> <p>5. Check if engine is overheating. (Refer to HIGH ENGINE OPERATING TEMPERATURE).</p> <p>6. Check carburetion. a. Fouled and/or improper carburetor components. <i>Clean or replace according to specifications (refer to TECHNICAL DATA).</i></p> <p>7. Check compression ratio and combustion chamber volume. a. Compression ratio is too high. <i>Install genuine parts.</i></p>

Section 02 TROUBLESHOOTING

Subsection 01 (ENGINE)

SYMPTOM	ENGINE TURNS OVER BUT FAILS TO START.
CONDITION	NORMAL USE.
TEST/INSPECTION	1. Check switches. a. Ignition switch, emergency cut-out switch or tether switch is OFF. <i>Place all switches in the RUN or ON position. If it still does not work, connect DESS switch BK/GN and BK/WH wires together (harness side).</i>
	2. Check fuel level. a. Mixture too lean to start cold engine. <i>Check fuel tank level and use choke.</i>
	3. Check spark plug. a. Defective spark plug (no spark) or wrong spark plug gap. <i>Replace spark plugs or readjust gap.</i>
	4. Check amount of fuel on spark plug. a. Flooded engine (spark plug wet when removed). <i>Do not overprime or overchoke. Remove wet spark plugs, turn ignition switch to OFF and crank engine several times. Install clean dry properly gapped spark plugs. Start engine following usual starting procedure.</i>
	5. Check fuel lines. a. No fuel to the engine (spark plugs dry when removed). <i>Check fuel tank level ; turn fuel valve on if applicable; check fuel filter, replace if clogged ; check condition of fuel and impulse lines and their connections.</i>
	6. Check engine compression. a. Insufficient engine compression. <i>Replace defective part(s) (ex.: piston(s), ring(s), etc.).</i>
	7. On SDI manual start models, check capacitor. a. Damaged capacitor. <i>Replace.</i>

Section 02 TROUBLESHOOTING
Subsection 01 (ENGINE)

SYMPTOM	IRREGULAR ENGINE IDLE.
CONDITION	NORMAL USE AFTER ENGINE WARM UP.
TEST/INSPECTION	<p>1. Check choke. a. Choke plunger may be partially opened. <i>Readjust.</i></p> <p>2. Check carburetor adapter. a. Air enters through a crack. <i>Replace.</i></p> <p>3. Check air screw position. a. Inadequate fuel/air mixture. <i>Adjust according to specifications (refer to TECHNICAL DATA).</i></p> <p>4. Check dimension of pilot jet. a. Inadequate fuel/air mixture. <i>Adjust according to specifications (refer to TECHNICAL DATA).</i></p> <p>5. Check reed valve. a. Improper tightness and/or opening. <i>Replace or adjust. Refer to proper ENGINE subsection.</i></p> <p>6. Perform engine leak test. a. Leaking gaskets allow air to enter in engine. <i>Replace defective parts.</i></p> <p>7. DPM manifold air vent is obstructed. a. Carburetion is too lean. <i>Ensure proper air vent.</i></p> <p>8. On models with carburetors, check throttle slide height. a. Incorrect throttle slide height. <i>Readjust according to specifications.</i></p> <p>9. On SDI models, check cleanness of throttle body. a. Deposits inside throttle body. <i>Clean throttle body bores and plates.</i></p>

Section 02 TROUBLESHOOTING

Subsection 01 (ENGINE)

SYMPTOM	HIGH ENGINE OPERATING TEMPERATURE.
CONDITION	NORMAL USE.
TEST/INSPECTION	<p>Fan-Cooled Engines</p> <ol style="list-style-type: none"> 1. Check cooling system. <ol style="list-style-type: none"> a. Loose fan belt. <i>Adjust or replace fan belt (refer to COOLING SYSTEM).</i> b. Dirty cooling fins or blocked air ducts. <i>Clean.</i> <hr/> <p>Liquid-Cooled Engines</p> <ol style="list-style-type: none"> 1. Check coolant level and check if there is air infiltration in the system or if there are leaks in gasket areas. <ol style="list-style-type: none"> a. Low coolant level or air in system. <i>Add coolant until recommended level is reached, bleed system and/or tighten clamps.</i> 2. Check temperature gauge sensor. <ol style="list-style-type: none"> a. False reading. <i>Check terminal connections. If problem persists, replace sensor.</i> 3. Check if heat exchangers are clean. <ol style="list-style-type: none"> a. Dirty heat exchangers. <i>Clean heat exchangers.</i> 4. Check if coolant flows through system properly. <ol style="list-style-type: none"> a. Foreign particles and/or broken coolant pump impeller. <i>Clean cooling system and/or replace coolant pump impeller.</i> 5. Check antifreeze concentration. <ol style="list-style-type: none"> a. Antifreeze concentration is too high. <i>Adjust concentration according to BRP's recommendations.</i> 6. Check thermostat. <ol style="list-style-type: none"> a. Thermostat reacts slowly or not at all. <i>Replace.</i> 7. Check tank cap. <ol style="list-style-type: none"> a. Cap does not hold pressure. <i>Replace.</i> 8. Check condition and heat range of spark plugs. <ol style="list-style-type: none"> a. Melted spark plug tip or inadequate heat range. <i>Replace.</i> 9. Check carburetion. <ol style="list-style-type: none"> a. Improperly adjusted or inadequate carburetor components. <i>Adjust according to specifications (refer to TECHNICAL DATA) or replace inadequate component(s).</i> 10. Check cylinder O-rings. <ol style="list-style-type: none"> a. Worn O-rings. <i>Replace.</i>

Section 02 TROUBLESHOOTING

Subsection 01 (ENGINE)

SYMPTOM	HIGH ENGINE OPERATING TEMPERATURE.
CONDITION	NORMAL USE.
TEST/INSPECTION	<p>Liquid-Cooled Engines (cont'd)</p> <p>11. Check ignition timing.</p> <p>a. Ignition timing is too advanced. <i>Adjust according to specifications (refer to TECHNICAL DATA).</i></p> <p>12. Check if there are leaks at air intake silencer and/or engine crankcase.</p> <p>a. Leak(s). <i>Repair or replace.</i></p> <p>13. Check cylinder head gaskets.</p> <p>a. Worn gaskets. <i>Replace.</i></p>

SYMPTOM	ENGINE EQUIPPED WITH RAVE VALVE DOES NOT REACH ITS FULL OPERATING RPM (500 TO 1000 RPM SLOWER).
CONDITION	NORMAL USE.
TEST/INSPECTION	<p>1. Check RAVE valve pistons.</p> <p>a. Valve piston(s) is (are) not screwed to the bottom. <i>Screw valve piston(s) to bottom.</i></p> <hr/> <p>2. Check that valve moves freely.</p> <p>a. Valve stuck in closed position. <i>Clean.</i></p> <hr/> <p>3. Check RAVE valve stems.</p> <p>a. Bent RAVE valve stem(s). <i>Replace.</i></p> <hr/> <p>4. Check RAVE valves.</p> <p>a. Jammed valve(s). <i>Clean.</i></p> <hr/> <p>5. Check tension of RAVE springs.</p> <p>a. Inadequate spring tension. <i>Replace.</i></p> <p>b. Inadequate red cap adjustment. <i>Adjust according to specifications.</i></p> <hr/> <p>6. Check RAVE pressure holes. (except SDI and Power Tek)</p> <p>a. Clogged holes. <i>Clean.</i></p> <hr/> <p>7. Check clamps or sleeves.</p> <p>a. Damaged clamp(s) or sleeve(s). <i>Replace.</i></p> <hr/> <p>8. Check exhaust tightness. (except SDI and Power Tek)</p> <p>a. Exhaust system is leaking leading to a too low back pressure. <i>Replaces parts and reseal.</i></p>

Section 02 TROUBLESHOOTING

Subsection 01 (ENGINE)

SYMPTOM	ENGINE EQUIPPED WITH RAVE. ENGINE HESITATES AT LOW OR MID-SPEED AND REACHES MAXIMUM PERFORMANCE ONLY AFTER A WHILE.
CONDITION	NORMAL USE.
TEST/INSPECTION	1. Check RAVE valve spring(s). a. Spring tension is too low or spring(s) is (are) broken. <i>Replace.</i>
	2. Check RAVE valve cover red adjustment screws. a. Adjustment screw(s) is (are) too loose. <i>Adjust according to ASSEMBLY PROCEDURE in appropriate engine subsections.</i>
	3. Check RAVE valve movement (RAVE movement indicator P/N 861 725 800). a. Valve(s) is (are) stuck in open position. <i>Clean.</i>

SYMPTOM	REWIND STARTER ROPE DOES NOT REWIND.
CONDITION	NORMAL USE.
TEST/INSPECTION	1. Check rewind spring. a. Broken spring. <i>Replace spring.</i>

SYMPTOM	REWIND STARTER PAWL DOES NOT ENGAGE.
CONDITION	NORMAL USE.
TEST/INSPECTION	1. Check stopper spring. a. Broken stopper spring. <i>Replace.</i>
	2. Check pawl and pawl lock. a. Pawl and pawl lock have stuck together because of heat. <i>Replace.</i>
	3. Check pawl and rope sheave. a. Pawl and rope sheave have stuck together because of heat. <i>Replace.</i>

Section 02 TROUBLESHOOTING
Subsection 01 (ENGINE)

SYMPTOM	ENGINE PINGING.
CONDITION	NORMAL USE.
TEST/INSPECTION	<p>1. Check for proper fuel octane number according to engine type.</p> <p>a. Too low fuel octane number. <i>Use appropriate fuel octane number (Refer to Operator's Guide).</i></p> <p>2. Check fuel lines.</p> <p>a. Bent fuel lines (preventing fuel from flowing through). <i>Relocate or replace fuel lines.</i></p> <p>3. Check if carburetor(s) is (are) clean.</p> <p>a. Dirt prevents fuel from flowing through. <i>Clean.</i></p> <p>4. Check ignition timing.</p> <p>a. Timing is too advanced. <i>Adjust according to specifications (refer to TECHNICAL DATA).</i></p> <p>5. Check compression ratio.</p> <p>a. Compression ratio is too high. <i>Replace inadequate part(s) to obtain manufacturer's recommended compression ratio or use a higher grade fuel.</i></p> <p>6. Check for carbon accumulation in combustion chamber and/or on piston dome.</p> <p>a. Carbon accumulation. <i>Remove carbon accumulation.</i></p>

SYMPTOM	ENGINE GENERATES A LOT OF VIBRATIONS.
CONDITION	NORMAL USE.
TEST/INSPECTION	<p>1. Check engine supports and stopper.</p> <p>a. Loose and/or broken supports or interference between support(s) and chassis. <i>Retighten to specification (refer to TECHNICAL DATA) or replace.</i></p> <p>2. Check drive pulley.</p> <p>3. Check carburetor synchronization.</p> <p>a. Throttle slide height is not the same on each carburetor and/or throttle slides opening is unsynchronized. <i>Adjust throttle slide heights and throttle cable.</i></p> <p>4. Check for crankshaft and bearings.</p> <p>a. Loose crankshaft bearings or uneven crankshaft. <i>Retighten or replace the parts.</i></p>

FUEL AND OIL SYSTEMS

The following chart is provided to help diagnose the probable source of troubles. It should be used as a guideline. Some causes or corrections may not apply to a specific model.

NOTE: For the SDI and Power Tek engines, also refer to appropriate ENGINE MANAGEMENT section.

SYMPTOM	HIGH FUEL CONSUMPTION OR RICH MIXTURE (MODELS WITH CARBURETOR ONLY).
CONDITION	NORMAL USE
TEST/INSPECTION	1. Check fuel tank. a. Perforated fuel tank. <i>Replace fuel tank.</i>
	2. Check fuel pump, reservoir and carburetor fittings. a. Leaking fittings. <i>Replace defective part.</i>
	3. Check choke adjustment. a. Fuel flows through choke circuit while engine runs. <i>Readjust choke.</i>
	4. Check float height in carburetor(s). a. Fuel level is too high in float bowl(s). <i>Adjust according to specifications (refer to TECHNICAL DATA).</i>
	5. Check needle valve on each carburetor. a. Foreign particles prevent needle valve from closing and/or pounded seating area. <i>Clean or replace needle valve, then clean seating area.</i>

SYMPTOM	FUEL LEAKS IN ENGINE BASE WHEN ENGINE IS STOPPED (MODELS WITH CARBURETOR ONLY).
CONDITION	NORMAL USE
TEST/INSPECTION	1. Check items 3, 4 and 5 of HIGH FUEL CONSUMPTION.
	2. Check fuel pump diaphragm. a. Cracked diaphragm. <i>Replace.</i>

Section 02 TROUBLESHOOTING

Subsection 02 (FUEL AND OIL SYSTEMS)

SYMPTOM	ENGINE LACKS POWER OR STALLS AT HIGH RPM (MODELS WITH CARBURETOR ONLY).
CONDITION	NORMAL USE
TEST/INSPECTION	1. Check fuel tank vent hose. <ul style="list-style-type: none"> a. Kinked or clogged hose. <i>Relocate or replace.</i>
	2. Check in-tank fuel filter. <ul style="list-style-type: none"> a. Clogged filter. <i>Replace.</i>
	3. Check fuel lines. <ul style="list-style-type: none"> a. Kinked or clogged lines. <i>Relocate or replace.</i>
	4. Check fuel pump flow. <ul style="list-style-type: none"> a. Check impulse hose. <i>Replace.</i> b. Dried diaphragm. <i>Replace.</i>
	5. Check if carburetor(s) is (are) clean. <ul style="list-style-type: none"> a. Varnish. <i>Clean.</i>

SYMPTOM	HIGH INJECTION OIL CONSUMPTION.
CONDITION	NORMAL USE
TEST/INSPECTION	1. Check oil injection pump adjustment. <ul style="list-style-type: none"> a. Oil injection pump adjusted too rich. <i>Adjust.</i>
	2. Check injection pump identification. <ul style="list-style-type: none"> a. Wrong pump. <i>Replace with the appropriate pump. Refer to OIL INJECTION SYSTEM.</i>
	3. Check injection oil lines and their fitting. <ul style="list-style-type: none"> a. Leaking lines and/or cover. <i>Replace defective part(s).</i>
	4. Check injection pump cover gasket. <ul style="list-style-type: none"> a. Broken gasket. <i>Replace.</i>
	5. Check nipple check valve. <ul style="list-style-type: none"> a. Check valve stuck open. <i>Replace.</i>
	6. Check pump. <ul style="list-style-type: none"> a. Defective pump. <i>Replace pump or connecting cable.</i>
	7. Test pump shaft gear reservoir for leaks. <ul style="list-style-type: none"> a. Leaking seal(s). <i>Replace seal(s).</i>

Section 02 TROUBLESHOOTING
Subsection 02 (FUEL AND OIL SYSTEMS)

SYMPTOM	ENGINE LACKS FUEL/WILL NOT RESTART (SDI MODELS ONLY).
CONDITION	AFTER RUNNING OUT OF FUEL
TEST/INSPECTION	<ol style="list-style-type: none"> 1. Fuel tank is not filled up. <ol style="list-style-type: none"> a. Electric fuel pump reservoir inside fuel tank is empty. <i>Fill up fuel tank or pull start engine several times to activate diaphragm fuel pump.</i>

SYMPTOM	ENGINE LACKS FUEL (SDI MODELS ONLY).
CONDITION	NORMAL USE
TEST/INSPECTION	<ol style="list-style-type: none"> 1. Check in-tank and in-line fuel filters. <ol style="list-style-type: none"> a. Clogged filter(s). <i>Replace fuel filter(s).</i> 2. Check if lines are perforated, kinked, or if they leak at fittings. <i>Replace lines.</i> 3. Check diaphragm fuel pump. <ol style="list-style-type: none"> a. Check impulse hose. <i>Replace.</i> b. Dried diaphragm. <i>Replace.</i> 4. Check electric fuel pump pressure. <ol style="list-style-type: none"> a. Electric fuel pump defective. b. Regulator defective. <i>Replace.</i> 5. Check fuel injectors flow. <ol style="list-style-type: none"> a. Dirty or defective injectors. <i>Replace.</i>

SYMPTOM	ENGINE IS TOO RICH OR TOO LEAN (MODELS WITH DPM SYSTEM ONLY).
CONDITION	NORMAL USE
TEST/INSPECTION	<ol style="list-style-type: none"> 1. Check electrical connections of DPM solenoid. <ol style="list-style-type: none"> a. Corroded terminals. <i>Clean or replace.</i> 2. Fuel mixture is too rich or too poor. <ol style="list-style-type: none"> a. Possible damage to DPM. <i>If DPM does not operate properly, unplug compensation solenoid connector while engine is running. The carburetion is now identical to that of carburetors without a DPM, provided that all pipe fittings are tight and that solenoid is in good condition, (it must not be half-open). If problem is resolved with this procedure, DPM is faulty.</i> 3. Check for DPM manifold leaking. <ol style="list-style-type: none"> a. DPM manifold is leaking. <i>Repair or replace.</i>

DRIVE AND BRAKE SYSTEMS

The following chart is provided to help diagnose the probable source of troubles. It should be used as a guideline. Some causes or corrections may not apply to a specific model.

DRIVE SYSTEM

SYMPTOM	THE SNOWMOBILE ACCELERATES SLOWLY, ESPECIALLY FROM A STANDING START.
CONDITION	NORMAL USE
TEST/INSPECTION	<p>1. Check drive belt condition.</p> <p>a. Belt is too narrow (drive belt engagement is higher in drive pulley). <i>Replace belt if width is less than specified in DRIVE BELT.</i></p> <p>2. Check drive belt deflection.</p> <p>a. Deflection is too high (drive belt engagement is higher in drive pulley). <i>Adjust drive belt height according to specifications (refer to PULLEY ALIGNMENT and DRIVE BELT).</i></p> <p>3. Check if driven pulley sliding half slides freely.</p> <p>a. Jammed sliding half. <i>Replace.</i></p> <p>4. Check spring tension of driven pulley sliding half.</p> <p>a. Sliding half rotation is accelerated when spring tension is too weak. <i>Adjust according to specifications (refer to TECHNICAL DATA).</i></p> <p>5. Refer to VIBRATIONS ORIGINATING FROM DRIVE PULLEY and VIBRATIONS ORIGINATING FROM DRIVEN PULLEY and check items listed.</p> <p>6. Check drive pulley spring tension.</p> <p>a. Spring tension is too weak. <i>Replace.</i></p>

SYMPTOM	ENGINE MAXIMUM RPM IS TOO HIGH AND TOP SPEED IS NOT REACHED.
CONDITION	NORMAL USE
TEST/INSPECTION	<p>1. Check items 1, 2 and 3 of THE SNOWMOBILE ACCELERATES SLOWLY, ESPECIALLY FROM A STANDING START.</p> <p>2. Check driven pulley spring tension.</p> <p>a. Spring tension is too stiff. <i>Adjust according to specifications (refer to TECHNICAL DATA).</i></p> <p>3. Check position of the calibration screws. (TRA drive pulley)</p> <p>a. Selected numbers are too high. <i>Adjust according to specifications (refer to TECHNICAL DATA).</i></p> <p>4. Refer to VIBRATIONS ORIGINATING FROM DRIVE PULLEY and check items listed.</p> <p>5. Check the driven pulley.</p> <p>a. Driven pulley does not open completely. <i>Clean, readjust or replace driven pulley.</i></p> <p>6. Check if levers of drive pulley move freely.</p> <p>a. Stuck levers. <i>Replace lever bushings.</i></p>

Section 02 TROUBLESHOOTING

Subsection 03 (DRIVE AND BRAKE SYSTEMS)

SYMPTOM	LOOSE IN DRIVE SYSTEM WHEN ACCELERATING/DECELERATING.
CONDITION	NORMAL USE
TEST/INSPECTION	1. Check drive chain tension. a. Drive chain is too loose. <i>Adjust.</i>
	2. Check radial play of driven pulley. a. Worn splines. <i>Replace pulley.</i>

SYMPTOM	VIBRATIONS ORIGINATING FROM DRIVE PULLEY.
CONDITION	NORMAL USE
TEST/INSPECTION	1. Check drive belt. a. Belt width is uneven on several places. <i>Replace.</i>
	2. Check tightening torque of drive pulley screw. a. Moving governor cup. <i>Retighten screw.</i>
	3. Spring cover screws. a. Spring cover moves and restrains sliding half movement. <i>Retighten screws.</i>
	4. Check spring cover (TRA TYPE) and/or sliding half bushings. a. Excessive gap between bushings and fixed half shaft, thus restraining sliding half movements. <i>Replace bushing(s).</i>
	5. Check governor cup splines. a. Excessive radial play. <i>Replace governor cup.</i>
	6. Check lever assembly. a. Lever assembly is damaged (worn bushing, bent lever etc.). <i>Replace damaged part.</i>

SYMPTOM	VIBRATIONS ORIGINATING FROM DRIVEN PULLEY.
CONDITION	NORMAL USE
TEST/INSPECTION	1. Check sliding half side play. a. Sliding half bushing worn out. <i>Replace sliding half bushing.</i>
	2. Check sliding half and fixed half straightness. a. Sliding half/fixed half warped. <i>Replace.</i>
	3. Check cam slider shoes. a. One or two slider shoes out of three are broken. <i>Replace.</i>

Section 02 TROUBLESHOOTING
Subsection 03 (DRIVE AND BRAKE SYSTEMS)

SYMPTOM	PULLEYS DO NOT DOWN SHIFT PROPERLY.
CONDITION	NORMAL USE
TEST/INSPECTION	1. Check driven pulley spring tension. a. Spring tension is too low. <i>Adjust according to specifications (refer to TECHNICAL DATA) or replace spring.</i>
	2. Refer to VIBRATIONS COMING FROM DRIVEN PULLEY and check items listed.
	3. Check drive pulley bushings (cleanliness, wear, etc.). a. Bushings stick to fixed half pulley shaft. <i>Clean or replace.</i>

SYMPTOM	IN REVERSE ENGINE FAILS AND DRIVEN PULLEY OPENS TOO FAST (DRIVE BELT IS LOW IN DRIVEN PULLEY).
CONDITION	NORMAL USE
TEST/INSPECTION	1. Check pulley alignment. a. Improper adjustment. <i>Adjust according to specifications (refer to PULLEY ALIGNMENT) and make sure that engine stopper is resting against engine.</i>
	2. Check for reverse sliding shoes. a. Sliding shoes are worn or missing. <i>Replace sliding shoes.</i>
	3. Check spring. a. Spring is weak or insufficient tension. <i>Replace spring.</i>

SYMPTOM	UNEVEN BELT WEAR ON ONE SIDE.
CONDITION	NORMAL USE
	1. Check tightening torque of engine mount bolts. a. Loose engine mount. <i>Tighten mount nuts/bolts equally.</i>
	2. Check pulley alignment. a. Pulley misalignment. <i>Align pulleys.</i>
	3. Check drive belt contact area on pulleys. a. Rough or scratched pulley surfaces. <i>Repair or replace pulley half.</i>
	4. Check driven pulley sliding half play. a. Driven pulley bushing worn. <i>Replace bushing.</i>

Section 02 TROUBLESHOOTING

Subsection 03 (DRIVE AND BRAKE SYSTEMS)

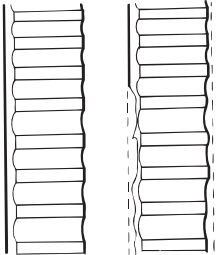
SYMPTOM	BELT TOO NARROW ON ONE SECTION.
CONDITION	NORMAL USE
TEST/INSPECTION 	1. Check for frozen track. a. Frozen track. <i>Free track from ice.</i>
	2. Check parking brake. a. Parking brake is engaged. <i>Release parking brake.</i>
	3. Check track tension/alignment. a. Track too tight. <i>Adjust track tension and alignment.</i>
	4. Check drive pulley. a. Drive pulley does not operate properly. <i>Repair or replace drive pulley.</i>
	5. Check idle speed. a. Engine idle speed is too high. <i>Adjust according to specifications.</i>
	6. Check drive belt length. a. Incorrect belt length. <i>Replace with an appropriate drive belt (refer to TECHNICAL DATA).</i>
	7. Check belt height. a. Belt height is incorrect. <i>Adjust according to specifications.</i>

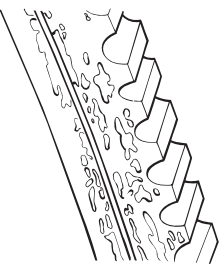
SYMPTOM	BELT GLAZED EXCESSIVELY OR HAVING BAKED APPEARANCE.
CONDITION	NORMAL USE
TEST/INSPECTION 	1. Check if drive pulley bushings are worn. a. Slipping due to insufficient pressure on belt sides. <i>Replace bushing.</i>
	2. Check condition of drive pulley fixed half shaft. a. Slipping due to rusted drive or driven pulley shafts. <i>Clean shaft with fine steel wool.</i>
	3. Check if pulley halves are clean. a. Slipping due to oily pulley surfaces. <i>Clean pulley halves.</i>
	4. Check pulley calibration. a. Slipping due to improper pulley calibration. <i>Calibrate according to specifications.</i>

Section 02 TROUBLESHOOTING

Subsection 03 (DRIVE AND BRAKE SYSTEMS)

SYMPTOM	BELT WORN EXCESSIVELY IN TOP WIDTH.
CONDITION	NORMAL USE
TEST/INSPECTION	<ol style="list-style-type: none"> 1. Check drive pulley. <ol style="list-style-type: none"> a. Excessive slippage due to jamming of drive pulley. <i>Inspect drive pulley.</i> 2. Check drive belt identification number. <ol style="list-style-type: none"> a. Improper belt angle (wrong type of belt). <i>Replace belt with an appropriate drive belt.</i> 3. Check drive belt width. <ol style="list-style-type: none"> a. Considerable use. <i>Replace belt if less than specified in DRIVE BELT.</i>

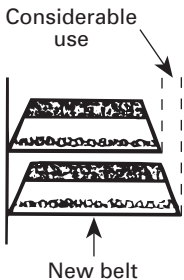

SYMPTOM	BELT SIDES WORN CONCAVE.
CONDITION	NORMAL USE
TEST/INSPECTION	<ol style="list-style-type: none"> 1. Check pulley half surfaces. <ol style="list-style-type: none"> a. Rough or scratched pulley half surfaces. <i>Repair or replace.</i> 2. Check drive belt identification number. <ol style="list-style-type: none"> a. Wrong belt. <i>Replace with an appropriate drive belt (refer to TECHNICAL DATA).</i>



SYMPTOM	BELT DISINTEGRATION.
CONDITION	NORMAL USE
TEST/INSPECTION	<ol style="list-style-type: none"> 1. Check drive belt identification number. <ol style="list-style-type: none"> a. Excessive belt speed. <i>Wrong type of belt. Replace with proper type of belt (refer to TECHNICAL DATA).</i> 2. Check if pulley halves are clean. <ol style="list-style-type: none"> a. Oil on pulley surfaces. <i>Clean pulley surfaces with fine emery cloth and wipe clean using pulley flange cleaner (P/N 413 711 809) and a cloth.</i>



SYMPTOM	BELT CORD POP OUT.
CONDITION	NORMAL USE
TEST/INSPECTION	<ol style="list-style-type: none"> 1. Check pulley alignment. <ol style="list-style-type: none"> a. Pulley misalignment. <i>Align pulley according to specifications (refer to TECHNICAL DATA).</i>



Section 02 TROUBLESHOOTING

Subsection 03 (DRIVE AND BRAKE SYSTEMS)

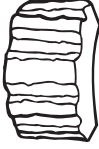
SYMPTOM	FATIGUE CRACKS BETWEEN COGS.
CONDITION	NORMAL USE
TEST/INSPECTION 	<ol style="list-style-type: none"> 1. Check drive belt condition. <ol style="list-style-type: none"> a. Belt considerably worn, worn out. <i>Replace.</i> b. Distortion of natural belt shape due to improper storage. <i>Store properly.</i>

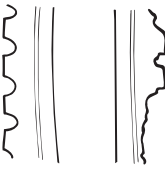
SYMPTOM	TOOTH CHUNK OUT.
CONDITION	NORMAL USE
TEST/INSPECTION 	<ol style="list-style-type: none"> 1. Check drive belt rotational direction. <ol style="list-style-type: none"> a. Improper belt installation. <i>Replace.</i> 2. Check if drive belt rubs against components. <ol style="list-style-type: none"> a. Belt rubs against fixed components. <i>Relocate components.</i> 3. Check drive pulley. <ol style="list-style-type: none"> a. Violent engagement of drive pulley. <i>Check drive pulley engagement speed, drive pulley bushings and components.</i>

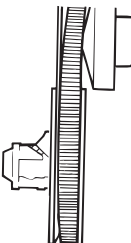
SYMPTOM	BELT "FLIP-OVER" AT HIGH SPEED.
CONDITION	NORMAL USE
TEST/INSPECTION 	<ol style="list-style-type: none"> 1. Check pulley alignment. <ol style="list-style-type: none"> a. Pulley misalignment. <i>Align pulley according to specifications (refer to TECHNICAL DATA).</i> 2. Check drive belt identification number. <ol style="list-style-type: none"> a. Wrong type of belt. <i>Replace with an appropriate drive belt.</i>

Section 02 TROUBLESHOOTING
Subsection 03 (DRIVE AND BRAKE SYSTEMS)

SYMPTOM	SLIDER SHOES WEAR OUT PREMATURELY/OR TRACK CLEATS BECOME BLUE.
CONDITION	NORMAL USE
TEST/INSPECTION	1. Check track tension. a. Pressure is too great on slider shoes. <i>Adjust according to specifications (refer to TECHNICAL DATA). Replace defective parts.</i>
	2. Check idler wheel condition. a. Stuck bearing, flat spot on wheel or damaged wheel. <i>Replace defective parts.</i>
	3. Check snow conditions or lack of snow. a. Lack of lubrication of slider shoes. <i>Ask driver to ride in appropriate snow conditions (see Operator's Guide).</i>
	4. Check slider shoes and/or suspension retaining screws. a. Twisted slider shoes or loose retaining screws. <i>Replace defective parts and/or tighten loose screws.</i>

SYMPTOM	DERAILING TRACK.
CONDITION	NORMAL USE
TEST/INSPECTION	1. Check track tension. a. Track is too loose. <i>Adjust.</i>
	2. Check if track and slider shoes are properly aligned. a. Improper alignment. <i>Adjust.</i>

SYMPTOM	NOISE OR VIBRATION COMING FROM THE TRACK.
CONDITION	NORMAL USE
TEST/INSPECTION	1. Check slide suspension retaining bolts. a. Missing bolt(s) (some components interfere with track rotation). <i>Replace missing bolt(s).</i>
	2. Check condition of idler wheel(s). a. Idler wheel rubber is damaged. <i>Replace.</i>
	3. Check guide cleats. a. Top portion of guide cleat(s) is bent. <i>Replace.</i>
	4. Check sprockets. a. One or several teeth of drive shaft sprockets are broken. <i>Replace sprocket(s).</i>
	5. Check track tension. a. Track is too loose. <i>Adjust to recommended tension.</i>
	6. Check track rods and/or internal traction teeth. a. One or several track rods and/or teeth are broken. <i>Replace track.</i>

Section 02 TROUBLESHOOTING
 Subsection 03 (DRIVE AND BRAKE SYSTEMS)

BRAKE SYSTEM

SYMPTOM	SPONGY BRAKE CONDITION.
CONDITION	NORMAL USE
TEST/INSPECTION	1. Contaminated brake fluid. <i>Replace brake fluid and bleed system. If the problem persists, replace master cylinder.</i>

SYMPTOM	BRAKE FLUID LEAKAGE.
CONDITION	NORMAL USE
TEST/INSPECTION	1. Check for loosen hose connectors. <i>Replace copper washers and retighten.</i>
	2. Check for damaged hose, master cylinder and caliper. <i>Replace part(s) and check for proper mounting.</i>

SYMPTOM	BRAKE SYSTEM IS NOISY.
CONDITION	NORMAL USE
TEST/INSPECTION	1. Check brake pad thickness. a. Pads are worn out. <i>Replace.</i>
	2. Check key and/or key way. a. Key and/or key way is(are) worn out. <i>Replace.</i>

ELECTRICAL SYSTEM

The following chart is provided to help diagnose the probable source of troubles. It should be used as a guideline. Some causes or corrections may not apply to a specific model.

SYMPTOM	STARTER DOES NOT TURN.
CONDITION	NORMAL USE
TEST/INSPECTION	<p>1. Check fuse. a. Burnt fuse. <i>Check wiring condition and replace fuse.</i></p> <p>2. On (SDI models), check sensors, ECM or MPEM. a. Faulty sensors or defective ECM or MPEM. <i>Using BUDS software, check faulty codes and diagnose all components. Repair defective part.</i></p> <p>3. Check battery charge. a. Discharged or disconnected battery. <i>Recharge battery and check charging system and wires.</i></p> <p>4. Check ground. a. Poor, or corroded ground contacts. <i>Check, clean and tighten.</i></p> <p>5. Check continuity of starter switch contact points. a. Poor contact of starter switch contact points. <i>Repair or replace switch.</i></p> <p>6. Check continuity between starter switch and solenoid on (fan-cooled models) or between starter switch and MPEM on (liquid-cooled models). a. Open circuit. <i>Repair.</i></p> <p>7. On (liquid-cooled models), check continuity between MPEM and solenoid switch. a. Open circuit. <i>Repair.</i></p> <p>8. On (SDI models), check relay no. 1. a. Poor connection or defective relay. <i>Clean, reconnect and/or replace.</i></p> <p>9. Check starter solenoid. a. Inadequate connection (too much resistance) or defective solenoid. <i>Clean, reconnect and/or replace.</i></p> <p>10. Check starter. a. Inadequate connection (too much resistance) or defective starter. <i>Reconnect and/or replace.</i></p> <p>11. Check engine problems. a. Damaged engine. <i>Check and repair.</i></p>

Section 02 TROUBLESHOOTING

Subsection 04 (ELECTRICAL SYSTEM)

SYMPTOM	STARTER TURNS BUT DOES NOT CRANK THE ENGINE.
CONDITION	NORMAL USE
TEST/INSPECTION	1. Check battery capacity. a. Shorted battery cell(s). <i>Replace.</i>
	2. Check battery charge. a. Low battery. <i>Recharge battery and check recharge system and wires.</i>
	3. Check wire connection. a. Inadequate connection (too much resistance). <i>Clean and reconnect.</i>
	4. Check solenoid switch contact disc. a. Burnt or poor contact of solenoid switch contact disc. <i>Replace solenoid switch.</i>
	5. Check brushes. a. Poor contact of brushes. <i>Replace brushes.</i>
	6. Check commutator. a. Burnt commutator. <i>Machine commutator on a lathe. Respect outer diameter wear limit. Refer to ELECTRIC STARTER.</i>
	7. Check engine. a. Engine seized. <i>Overhaul the engine.</i>
	8. Check height of commutator mica. a. Commutator mica too high. <i>Undercut mica.</i>
	9. Check field coil resistance. a. Shorted field coil. <i>Repair or replace yoke.</i>
	10. Check armature resistance. a. Shorted armature. <i>Repair or replace armature.</i>
	11. Check tension of brush springs. a. Weak brush spring tension. <i>Replace springs.</i>
	12. Check yoke assembly magnets. a. Weak magnets. <i>Replace yoke assembly.</i>
	13. Check if bushings are worn. a. Worn bushings. <i>Replace bushings.</i>

Section 02 TROUBLESHOOTING
Subsection 04 (ELECTRICAL SYSTEM)

SYMPTOM	STARTER TURNS, BUT OVERRUNNING CLUTCH PINION DOES NOT MESH WITH RING GEAR.
CONDITION	NORMAL USE
TEST/INSPECTION	1. Check clutch pinion gear. a. Worn clutch pinion gear. <i>Replace clutch.</i>
	2. Check clutch. a. Defective clutch. <i>Replace clutch.</i>
	3. Check brackets. a. Worn or broken brackets. <i>Replace brackets.</i>
	4. Check movement of clutch on splines. a. Poor movement of clutch on splines. <i>Clean and correct.</i>
	5. Check clutch bushing. a. Worn clutch bushing. <i>Replace clutch.</i>
	6. Check starter bushings. a. Worn starter bushing(s). <i>Replace bushing(s).</i>
	7. Check ring gear. a. Worn ring gear. <i>Replace ring gear.</i>
	8. Check for proper starter rotation direction. a. Starter turns in wrong direction, incorrectly installed brushes, wrong polarity or wrong starter. <i>Replace starter or reconnect properly.</i>

Section 02 TROUBLESHOOTING
Subsection 04 (ELECTRICAL SYSTEM)

SYMPTOM	ELECTRIC STARTER KEEPS TURNING WHEN ENGINE IS STARTED.
CONDITION	NORMAL USE
TEST/INSPECTION	1. Check clutch. a. Jammed clutch pinion gear. <i>Replace or clean.</i>
	2. Check movement of clutch on splines. a. Clutch is stuck on splines. <i>Clean.</i>
	3. Check starter brackets. a. Broken bracket(s). <i>Replace bracket(s).</i>
	4. On (fan-cooled models), check ignition switch. a. Ignition switch does not return to its ON position or is short-circuited. <i>Adjust switch position. Face nut is too far in..</i>
	5. Check starter relay. a. Shorted starter relay winding(s). <i>Replace starter relay.</i> b. Melted starter relay contacts. <i>Replace starter relay.</i> c. Starter relay returns poorly. <i>Replace starter relay.</i>
	6. Check start switch contacts. a. Contacts shorted. <i>Replace start switch.</i>

SYMPTOM	NOISE OCCURRENCE WHEN STARTING ENGINE.
CONDITION	NORMAL USE
TEST/INSPECTION	1. Check if ring gear is well-mounted to drive pulley fixed half. a. Loose and/or broken bolts. <i>Retighten bolts using thread locker or replace ring gear and drive pulley fixed half.</i>

SYMPTOM	ON FAN-COOLED MODELS, 20 A FUSE ON BLACK WIRE IN FRONT OF VEHICLE IS BURNT OUT.
CONDITION	NORMAL USE
TEST/INSPECTION	1. Check that big ground wire at battery is well connected to chassis. a. Corroded and/or loose connection(s). <i>Clean and/or retighten.</i>

Section 02 TROUBLESHOOTING
Subsection 04 (ELECTRICAL SYSTEM)

SYMPTOM	ELECTRIC STARTER SOMETIMES DOES NOT WORK WHEN ACTIVATED.
CONDITION	NORMAL USE
TEST/INSPECTION	1. Check battery cables and starter wires. a. Corroded and/or loose connection(s). <i>Clean and/or retighten.</i>
	2. Check fuse. a. Oxidized or burnt fuse. <i>Clean or replace.</i>
	3. Check wiring harness connections. a. Oxidized connections. <i>Clean or replace defective terminals.</i>
	4. Check ignition switch or START/RER switch. a. Defective contacts in ignition switch or in START/RER switch. <i>Replace.</i> b. Moisture in START/RER switch. <i>Blow dry START/RER switch.</i>
	5. Check solenoid of electric starter. a. Shorted solenoid wiring harness or corroded contact washer. <i>Replace.</i>

SYMPTOM	THE ECM AND/OR MPEM DOES NOT WORK.
CONDITION	NORMAL USE
TEST/INSPECTION	1. Check that high tension coil wires do not touch any metal parts. a. Short circuit. <i>Isolate and reroute wires.</i>
	1. On (SDI models), check codes in BUDS. a. Defective connections or faulty ECM. <i>Repair or replace.</i>

SYMPTOM	ENGINE STALLS.
CONDITION	NORMAL USE
TEST/INSPECTION	1. Refer to IGNITION SYSTEM DIAGNOSTIC FLOW CHART.

Section 02 TROUBLESHOOTING

Subsection 04 (ELECTRICAL SYSTEM)

SYMPTOM	ENGINE IS MISFIRING — ERRATIC SPARK AT SPARK PLUG.
CONDITION	RIDING ON WET SNOW.
TEST/INSPECTION	1. Check if spark plug wires and/or spark plug cap seals are sealing out moisture. a. Defective wires and/or seals. <i>Replace defective part.</i>
	2. Check if ignition system wiring harness connectors are in good condition and/or are sealing out moisture. a. Loose connectors, corroded terminals or defective parts. <i>Clean terminals and apply silicone dielectric grease. Replace defective parts.</i>
CONDITION	NORMAL USE
TEST/INSPECTION	1. Verify misfiring by observing flash of stroboscopic timing light; unplug connectors between magneto/generator and vehicle wiring harness to isolate problem. Check condition of connectors. a. Defective spark plug(s) and/or cable(s)/cap(s). Defective electrical system wiring harness and/or accessories and/ignition cut-out switches. Condition of connector terminals. <i>Replace defective parts and/or repair damaged wires. Replace defective switch(es). Clean terminals and apply silicone dielectric grease.</i>
CONDITION	RIDING IN DEEP AND THICK SNOW.
TEST/INSPECTION	1. Perform all verifications outlined under ENGINE DOES NOT START — NO SPARK AT SPARK PLUG.
	2. Check spark plugs. Proceed with spark plug analysis in order to identify source of problem. a. Defective and/or worn spark plug(s) and/or cable(s) and/or cap(s). Engine related problem. <i>Replace defective part(s). Proceed with ignition system testing procedures. Perform engine analysis.</i>

SYMPTOM	FOULED (BLACK) SPARK PLUG TIP.
CONDITION	NORMAL USE
TEST/INSPECTION	1. Check carburetor. a. Carburetion is too rich. <i>Adjust according to specifications (refer to TECHNICAL DATA).</i>
	2. Check injection oil consumption. a. Injection pump flow is too high. <i>Adjust according to specifications or replace.</i>
	3. Check oil quality. a. Poor quality oil (creation of deposits). <i>Use BRP XP-S injection oil.</i>
	4. Check engine compression. a. Leaking piston ring(s). <i>Replace.</i>

Section 02 TROUBLESHOOTING
Subsection 04 (ELECTRICAL SYSTEM)

SYMPTOM	SPARK PLUG TIP IS LIGHT GRAY.
CONDITION	NORMAL USE
TEST/INSPECTION	<p>1. Refer to ENGINE SLOWS DOWN OR STOPS AT HIGH RPM and check items listed.</p> <p>2. Check spark plug heat range. a. Spark plug heat range is too high. <i>Replace by BRP's recommended spark plug (refer to TECHNICAL DATA).</i></p> <p>3. Check if air intake silencer leaks. a. Air surplus coming from opening(s) located between halves. <i>Seal.</i></p> <p>4. Check carburetor adapter collars. a. Loose collar(s). <i>Tighten.</i></p> <p>5. Check carburetor adapter(s). a. Cracked or deformed adapter(s). <i>Replace.</i></p> <p>6. Check if primary compression leaks. a. Primary compression leaks. <i>Perform leak down test and repair as necessary.</i></p>

SYMPTOM	RER (ROTAX ELECTRONIC REVERSE) DOES NOT WORK.
CONDITION	NORMAL USE
TEST/INSPECTION	<p>1. Check idle speed. a. Wrong idle speed. <i>Adjust according to specification (refer to TECHNICAL DATA).</i></p> <p>2. Check spark plug. a. Faulty spark plug. <i>Replace.</i></p> <p>3. Check engine compression. a. Too low engine compression; engine stalls when pushing RER button. <i>Rebuilt the engine.</i></p> <p>4. Check drive belt height. a. Wrong belt height. <i>Adjust according to specification (refer to DRIVE BELT).</i></p> <p>5. Check carburetor synchronization and air screw adjustment. a. Wrong adjustment. <i>Adjust according to specification (refer to TECHNICAL DATA) and read carburetor subsection.</i></p> <p>6. Check switch electrical connections. a. Bad electrical connections or damaged wires. <i>Clean or replace.</i></p> <p>7. Check ECM or MPEM. a. Faulty ECM or MPEM. <i>Replace.</i></p>

Section 02 TROUBLESHOOTING

Subsection 04 (ELECTRICAL SYSTEM)

SYMPTOM	HEADLAMP NOT LIGHTING.
CONDITION	WHITE BULB.
TEST/INSPECTION	1. Check bulb. a. Gas leak. <i>Replace bulb.</i>
CONDITION	BROKEN ELEMENT.
TEST/INSPECTION	1. Check for loose headlamp housing and bulb socket. a. Vibration problem. <i>Tighten headlamp mounting screws. Lock bulb in socket. Replace bulb.</i>
CONDITION	MELTED FILAMENT (ENDS OF ELEMENT HOLDER) AND BLACK BULB.
TEST/INSPECTION	1. Check voltage at headlamp at different speeds. It must not be above 15 Vdc. NOTE: If quartz halogen bulb is involved, ensure that proper voltage regulator is installed. a. Excessive voltage in lighting circuit. <i>Replace voltage regulator and ensure proper grounding. Retest.</i>

SYMPTOM	HEADLAMP DIMMING.
CONDITION	NORMAL USE
TEST/INSPECTION	1. Check voltage at headlamp at different speeds. It must not be below 11 Vdc. a. Insufficient voltage in lighting circuit. <i>Replace voltage regulator and retest.</i>
	2. Visually inspect wiring harness for damaged and/or melted wires and/or bad wire terminal crimping and/or connections. a. Heating, rotating or sharp part in contact with harness. Improper harness routing. <i>Repair/replace damaged wires and/or terminals. Reroute harness where necessary.</i>
	3. On manual start models : Verify regulator ground. a. Rusted or loose retaining screws. <i>Clean, apply lithium grease (LMZ1) and firmly tighten screws.</i>
	3. On (fan-cooled models) , verify if there is an interconnection between AC and DC current. a. Faulty installation of optional equipment. <i>Find optional equipment connected directly to DC ground (BLACK wire or chassis) or to any DC hot wire (RED or RED/BLUE). Disconnect and reconnect to AC current (YELLOW and YELLOW/BLACK wires). Refer to the appropriate section.</i>
	5. Check if optional electric accessories are overloading the magneto/generator. a. Excessive electrical load to magneto/generator. <i>Reduce the electrical load by removing excess accessories. Reconnect as recommended by manufacturer.</i>
	6. Hot Grips brand: Verify if they were connected in parallel by mistake. a. Excessive electrical load to magneto/generator. <i>Reconnect as recommended by manufacturer.</i>
	7. BRP heating grips: Verify if the return wires of the elements were grounded to the chassis by mistake. a. Faulty installation of optional equipment. <i>Reconnect as recommended by manufacturer.</i>
	8. Check if heating grips installation overloads the magneto capacity. a. Excessive electrical load to magneto/generator. <i>Reduce the electrical load by removing accessories.</i>

Section 02 TROUBLESHOOTING
Subsection 04 (ELECTRICAL SYSTEM)

SYMPTOM	FALSE FUEL AND/OR TEMPERATURE GAUGE READINGS.
CONDITION	NORMAL USE
TEST/INSPECTION	1. On (fan-cooled models), verify if gauge was connected on DC current by mistake (in case of optional installation). a. Faulty installation of optional equipment. <i>Find optional wires connected directly to DC ground (BLACK wire to chassis) or to any DC hot wire (RED or RED/BLUE). Disconnect and reconnect to AC current (YELLOW and YELLOW/BLACK wires)</i>
	2. Verify sender unit for free movement and/or correct arm position. a. Defective or damaged part. <i>Correct or replace sender unit.</i>
	3. Verify sender unit/gauge wiring harness condition. a. Heating, rotating or sharp part in contact with harness. Improper harness routing. <i>Replace or repair damaged wires. Reroute where necessary.</i>

SYMPTOM	NO ELECTRICAL ACCESSORIES WORK WHEN ENGINE IS ON IDLE.
CONDITION	NORMAL USE
TEST/INSPECTION	1. Check idle speed. a. Too low idle speed. <i>Readjust to specifications.</i>
	2. Verify regulator. a. Faulty regulator. <i>Replace.</i>

SYMPTOM	BRAKE LIGHT REMAINS ON.
CONDITION	NORMAL USE
TEST/INSPECTION	1. Check if bulb is properly installed. a. Bulb is not installed correctly (contact elements are reversed). <i>Install bulb correctly.</i>
	2. Check brake switch. a. Switch contact remains closed. <i>Replace brake switch.</i>
	3. Check wiring harness. a. Shorted wiring harness. <i>Replace or repair wiring harness.</i>

SYMPTOM	REAR LIGHT BULB FLASHES.
CONDITION	NORMAL USE
TEST/INSPECTION	1. Check bulb tightness in housing. a. Looseness at bulb contact elements. <i>Install bulb correctly.</i>
	2. Check if rear light is properly connected. a. Connector housing is partially connected. <i>Install connector housing properly.</i>
	3. Check continuity of wires. a. Corroded terminals and/or broken wires. <i>Replace terminal(s) or crimp defective wires.</i>

Section 02 TROUBLESHOOTING

Subsection 04 (ELECTRICAL SYSTEM)

SYMPTOM	TACHOMETER DOES NOT WORK.
CONDITION	NORMAL USE
TEST/INSPECTION	1. Check continuity of wires. a. Corroded terminals and/or broken wires. <i>Replace terminal(s) or crimp defective wires.</i>
	2. Check tachometer part number. a. Models with 360 W magneto have a different tachometer. <i>Replace with appropriate one.</i>

STEERING AND SUSPENSION

The following chart is provided to help diagnose the probable source of troubles. It should be used as a guideline. Some causes or corrections may not apply to a specific model.

SYMPTOM	SUSPENSION IS TOO LOW.
CONDITION	NORMAL USE
TEST/INSPECTION	1. Check condition of springs. a. Springs are weakened or broken. <i>Replace springs.</i>
	2. Check springs preload. a. Low spring preload. <i>Increase preload to the recommended position.</i>
	3. Check springs. a. Installed springs are too soft. <i>Install optional stiffer springs, refer to service bulletin SPRING REFERENCE ACCORDING TO LOAD.</i>

SYMPTOM	REAR SUSPENSION BOTTOMS OUT.
CONDITION	NORMAL USE
TEST/INSPECTION	1. Check condition of springs. a. Springs are weakened or broken. <i>Replace springs.</i>
	2. Check springs preload. a. Low spring preload. <i>Increase preload to the recommended position.</i>
	3. Check springs. a. Springs installed are too soft. <i>Install optional stiffer springs, refer to service bulletin SPRING REFERENCE ACCORDING TO LOAD.</i>
	4. Check the rear shock motion ratio position. a. It is adjusted in soft position. <i>Adjust rear shock motion ratio to firm position.</i>
	5. Check condition of the rear shock absorber. a. Damaged rear shock absorber. <i>Replace rear shock absorber.</i>

Section 02 TROUBLESHOOTING
Subsection 05 (STEERING AND SUSPENSION)

SYMPTOM	REAR SUSPENSION IS TOO STIFF.
CONDITION	NORMAL USE
TEST/INSPECTION	1. Check rear spring preload. a. Too much preload. <i>Adjust to a softer position.</i>
	2. Check springs. a. Springs installed are too stiff. <i>Install optional softer springs, refer to service bulletin SPRING REFERENCE ACCORDING TO LOAD.</i>
	3. Check the rear shock motion ratio position. a. It is adjusted in firm position. <i>Adjust rear shock motion ratio to soft position.</i>
	4. Check track tension. a. Track is too tight. <i>Adjust.</i>
	5. Check if axles are properly lubricated. a. Improper lubrication and/or contaminated grease (sticky oil sludge). <i>Clean and/or lubricate.</i>
	6. Check condition of the rear shock absorber. a. Damaged rear shock absorber. <i>Replace rear shock absorber.</i>

SYMPTOM	WHEN HANDLEBAR IS TURNED, SNOWMOBILE UNDERSTEEERS.
CONDITION	NORMAL USE
TEST/INSPECTION	1. Check ski runner condition. a. Worn ski runners. <i>Replace.</i>
	2. Check ski spring preload. a. Insufficient ski pressure on the ground. <i>Increase spring preload.</i>
	3. Check if front arm stopper strap is too long. a. Insufficient ski pressure on the ground. <i>Shorten stopper strap.</i>
	4. Check front arm spring preload. a. Insufficient ski pressure on the ground. <i>Loosen spring tension.</i>

Section 02 TROUBLESHOOTING
Subsection 05 (STEERING AND SUSPENSION)

SYMPTOM	HANDLEBAR IS DIFFICULT TO TURN.
CONDITION	NORMAL USE
TEST/INSPECTION	1. Check if the handlebar turns freely when skis are off the ground. <ul style="list-style-type: none"> a. Ball joints corrosion restrains movement. <i>Lubricate or replace the ball joint.</i> b. Component need proper lubrication. <i>Lubricate. Refer to MAINTENANCE.</i> c. Bent parts. <i>Replace parts.</i>
	2. Check ski spring preload. <ul style="list-style-type: none"> a. Too much preload. <i>Reduce ski spring preload.</i>
	3. Check position of stopper strap. <ul style="list-style-type: none"> a. Too much weight when stopper strap is short. <i>Lengthen front arm stopper strap.</i>
	4. Check position of front arm spring adjustment cam(s). <ul style="list-style-type: none"> a. When spring tension is weak, more weight is transferred to the skis. <i>Increase spring preload.</i>
	5. Check swing arm camber. <ul style="list-style-type: none"> a. Too much ski leg inclination. <i>Adjust camber to specifications.</i>

SYMPTOM	THE SNOWMOBILE ZIGZAGS.
CONDITION	NORMAL USE
TEST/INSPECTION	1. Check ski runner condition. <ul style="list-style-type: none"> a. Worn or bent ski runners. <i>Replace ski runners.</i>
	2. Check ski alignment. <ul style="list-style-type: none"> a. Improper ski alignment. <i>Align skis in order to obtain proper toe-out (opening) (to adjust, refer to STEERING SYSTEM).</i>
	3. Check if bushings are too loose in steering system. <ul style="list-style-type: none"> a. Bushings are too loose. <i>Replace.</i>
	4. Check ski pressure. <ul style="list-style-type: none"> a. Too much pressure on skis. <i>Reduce ski spring preload and/or increase center spring preload.</i>
	NOTE: If all parts are in good condition and the customer still complains about an unstable snowmobile, consider the installation of optional Proactive Control System.

LEAK TEST

SERVICE TOOLS

Description	Part Number	Page
hose pincher.....	295 000 076	47
vacum/pressure pump kit.....	529 021 800	47

PREPARATION

Use vacum/pressure pump kit (P/N 529 021 800) to pressure test engine. The following gives verification procedures for liquid cooled engines though it also applies to fan cooled engines. For FC engines, do not consider information pertaining to coolant system and pump shaft oil gear reservoir.

On FC twin-cylinder engines, each cylinder cannot be verified individually due to leakage from one cylinder to the other through labyrinth sleeve in center of crankshaft.

- Remove tuned pipe.
- Install plug over exhaust manifold.
- Remove carburetors/throttle body assembly (as applicable).
- Unplug fuel inlet line from fuel rail.
- Insert plugs in intake rubber boots. Tighten with existing clamps.

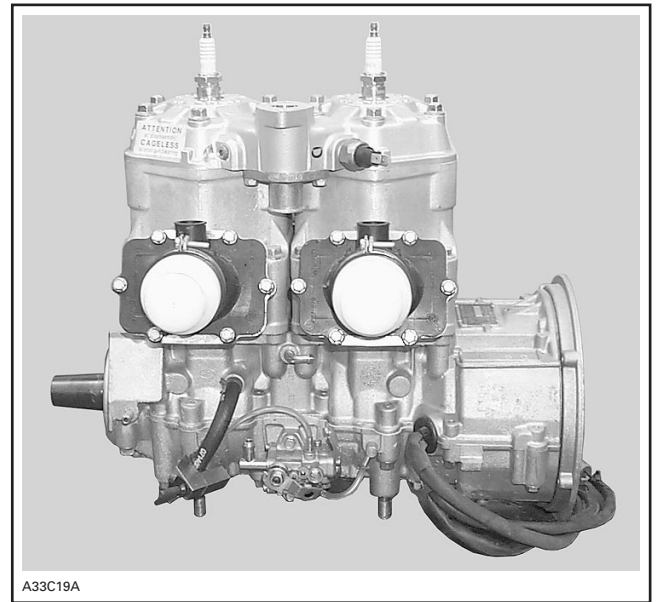

- Using a hose pincher (P/N 295 000 076), block impulse hose.
- Install air pump on exhaust plug.

NOTE: If necessary, lubricate air pump piston with mild soap.

CAUTION: Using hydrocarbon lubricant (such as engine oil) will damage rubber seal of pump piston.

Section 03 ENGINES

Subsection 01 (LEAK TEST)

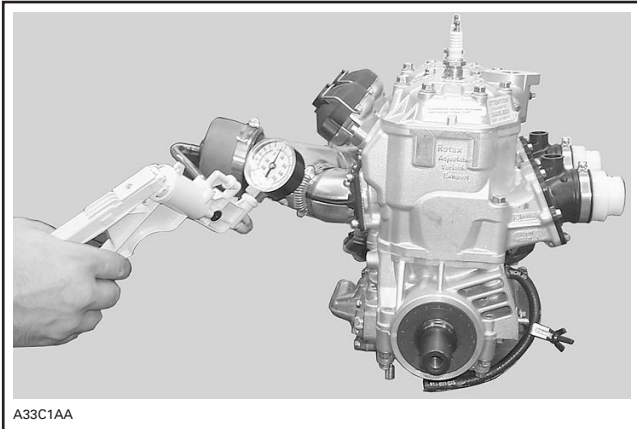

- Activate pump and pressurize engine to 34 kPa (5 PSI). Do not exceed this pressure.
- Engine must stand this pressure during 3 minutes. If pressure drops before 3 minutes, check tester kit by spraying a soapy solution on pump cylinder, all plugs and fittings.
 - If tester kit is leaking, bubbles will indicate where leak comes from.
 - If tester kit is not leaking, check engine as per following procedure.

PROCEDURE

NOTE: A flow chart has been prepared as a visual reference. See last page of this chapter.

Using flow chart and following text, pressurize area to be tested and spray soapy solution at the indicated location.

**TEST PRESSURE: 34 KPA (5 PSI)
FOR 3 MINUTES**

- If there is a leak at the tested location, it is recommended to continue testing next items before overhauling engine. There is a possibility of more than one leak.
- If there is no leak at the tested location, continue pumping to maintain pressure and continue with next items until leak is found.

Engine

Check the following:

- All jointed surfaces and screw/stud threads of engine:
 - spark plug base, insulator
 - cylinder head
 - RAVE valve bellows, piston and housing

- cylinder crankcase halves (joint)
 - oil injection pump mounting flange (O-ring)
 - coolant pump housing
 - bleed screws/plugs
 - crankcase grease reservoir fitting.
- Small injection oil lines coming from pump.

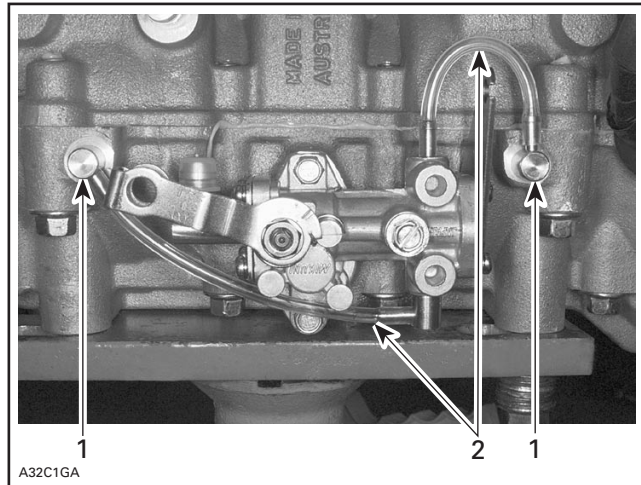

TYPICAL

1. Injection nipples
2. Small injection oil lines

Check for air bubbles or oil column going toward pump. It indicates defective check valve in injection nipples.

- Remove cooling system cap.

Check for air bubbles in antifreeze. It indicates defective cylinder head O-ring or cylinder base gasket.

- Remove drive pulley then check crankshaft outer seal.
- Remove rewind starter and magneto system then check crankshaft outer seal.
- Check pump shaft gear oil reservoir.

Pump Shaft Oil Gear Reservoir

Install air pump on adapter and pressurize as above.

Section 03 ENGINES
Subsection 01 (LEAK TEST)

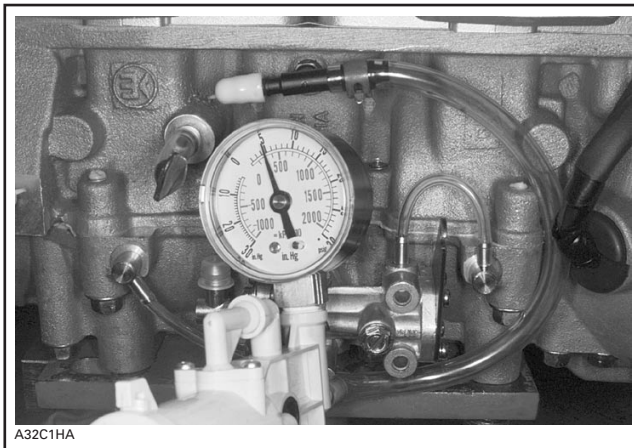

If pressure drops, it indicates a defective crankshaft inner seal.

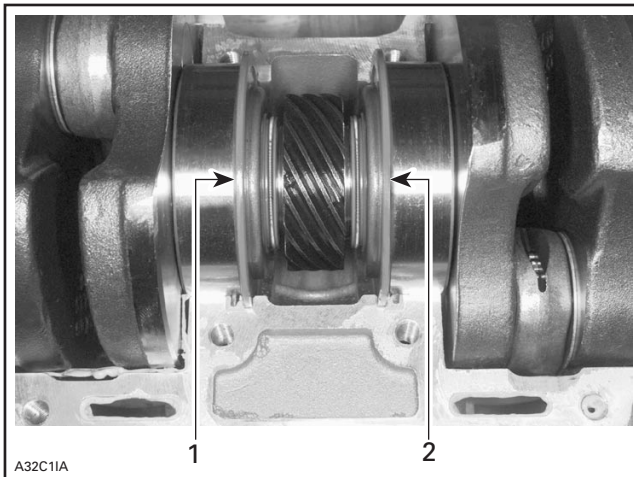

TYPICAL — CRANKSHAFT INSTALLED IN UPPER HALF CRANKCASE

1. Crankshaft inner seal on PTO side
2. Crankshaft inner seal on MAG side

– Check weep hole below coolant pump housing with soapy water.

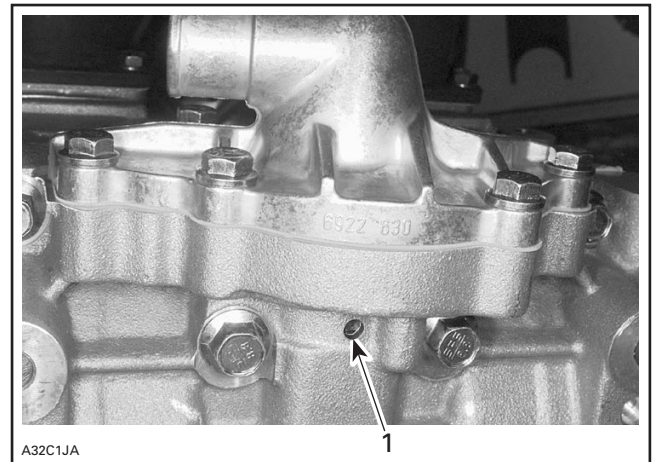

1. Weep hole

If there is a leak, it indicates that a pump shaft is defective (oil seal beside coolant ceramic seal).

– Leaks can be also on oil pump side. Check mounting area for leaks.

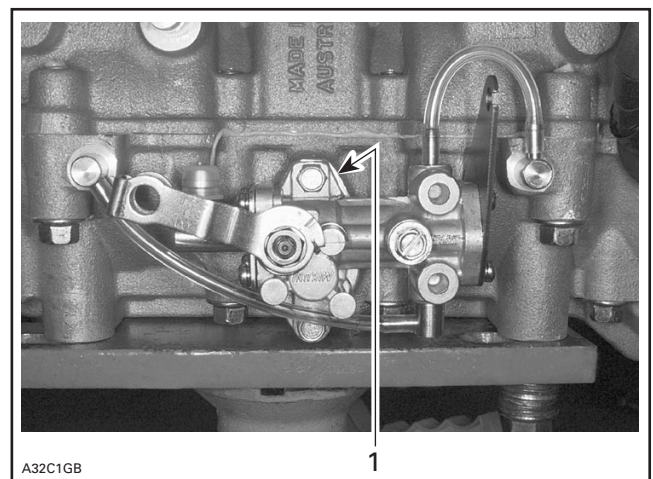

TYPICAL

1. Check mounting area

– If leak still persists, it indicates a defective casting somewhere in engine.

Disassemble engine and carefully check for defects in castings. Pay attention to tapped holes which may go through engine sealed area and thus lead to leakage.

FINALIZING REASSEMBLY

After reassembling engine, always recheck for leakage.

Section 03 ENGINES
Subsection 01 (LEAK TEST)

ENGINE LEAK VERIFICATION FLOW CHART

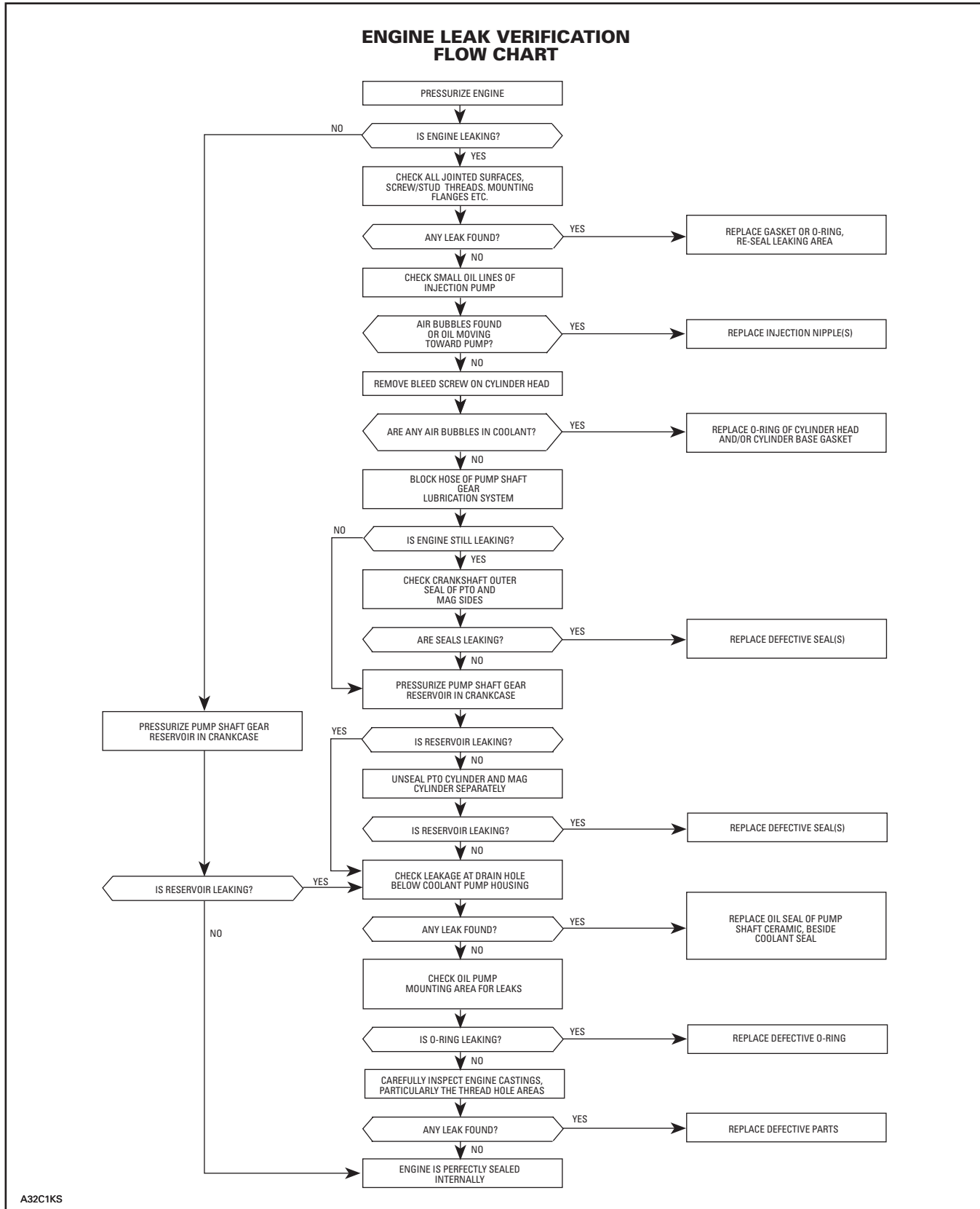

A32C1KS

EXHAUST SYSTEM

SERVICE TOOLS

<u>Description</u>	<u>Part Number</u>	<u>Page</u>
exhaust spring installer/remover	529 035 401	54-55

SERVICE PRODUCTS

<u>Description</u>	<u>Part Number</u>	<u>Page</u>
RTV sealant	293 800 090	55

Section 03 ENGINES

Subsection 02 (EXHAUST SYSTEM)

377 AND 552 ENGINES

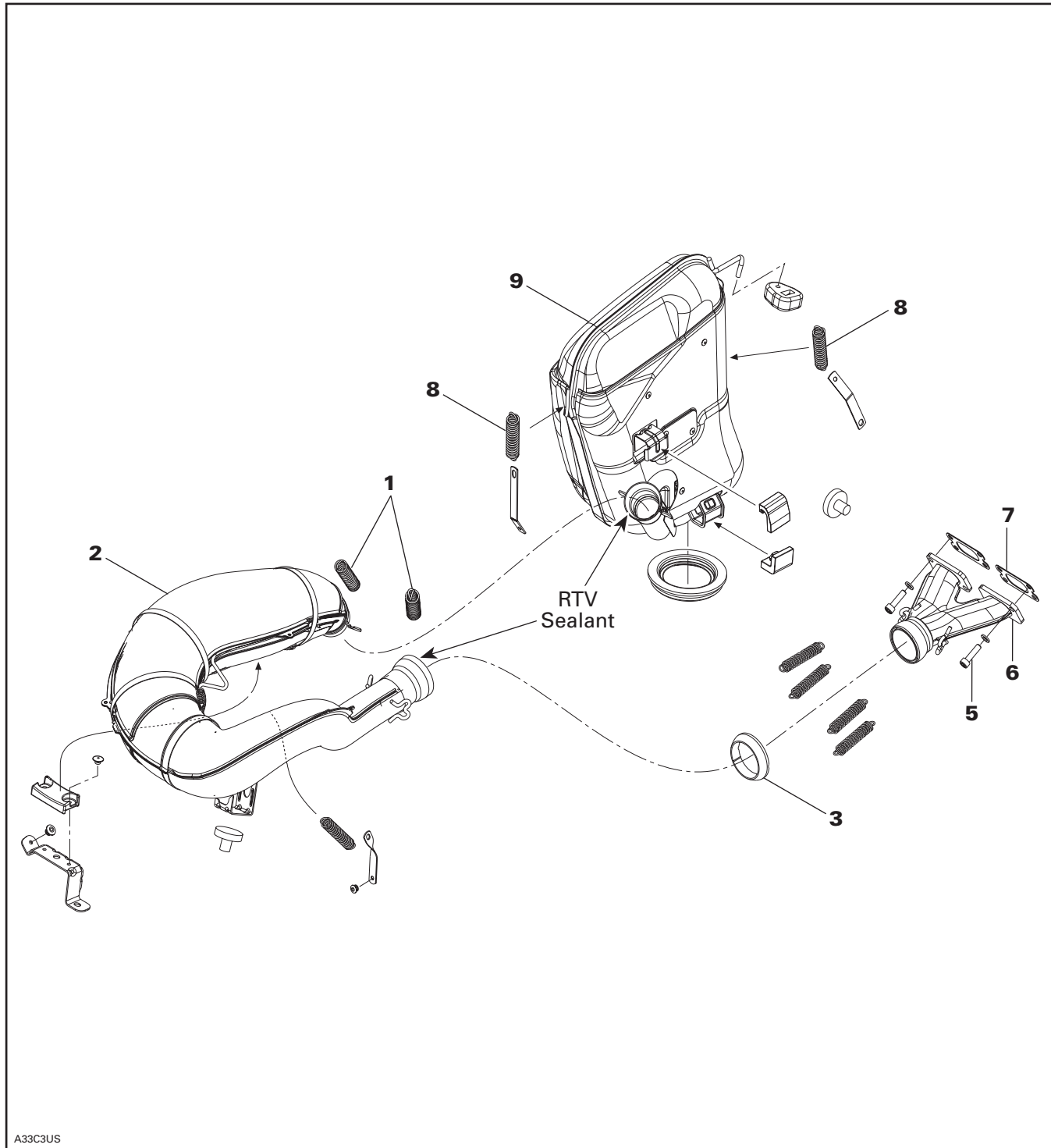

**593, 593 HO, 593 HO SDI
AND 793 HO ENGINES**

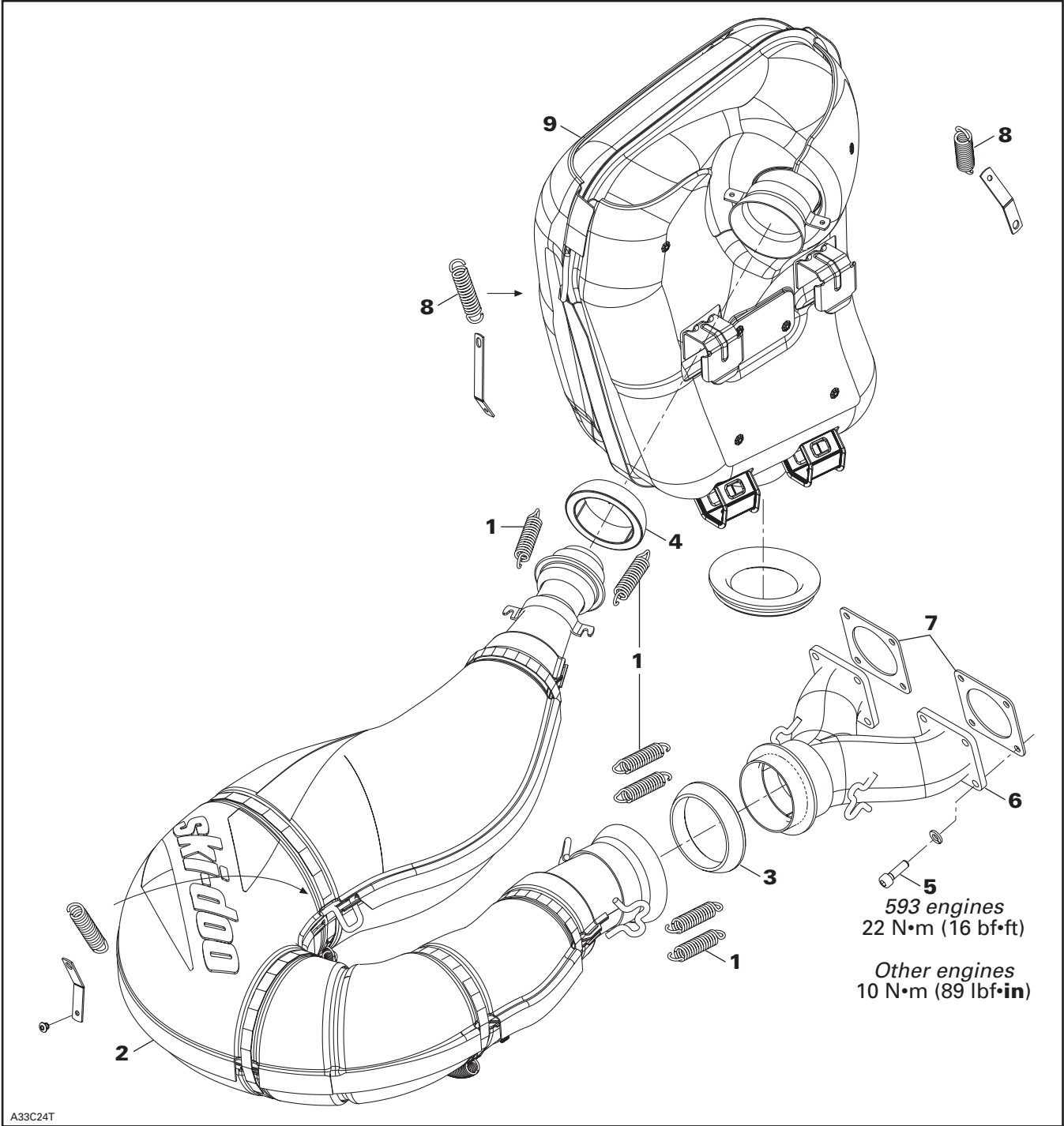

Section 03 ENGINES

Subsection 02 (EXHAUST SYSTEM)

TUNED PIPE

Identification

Each tuned pipe is identified by a number. To use the proper tuned pipe with the proper vehicle, check the number on the welded clamp at the end of tuned pipe. This number depicts the 6 last numbers of BRP part number.

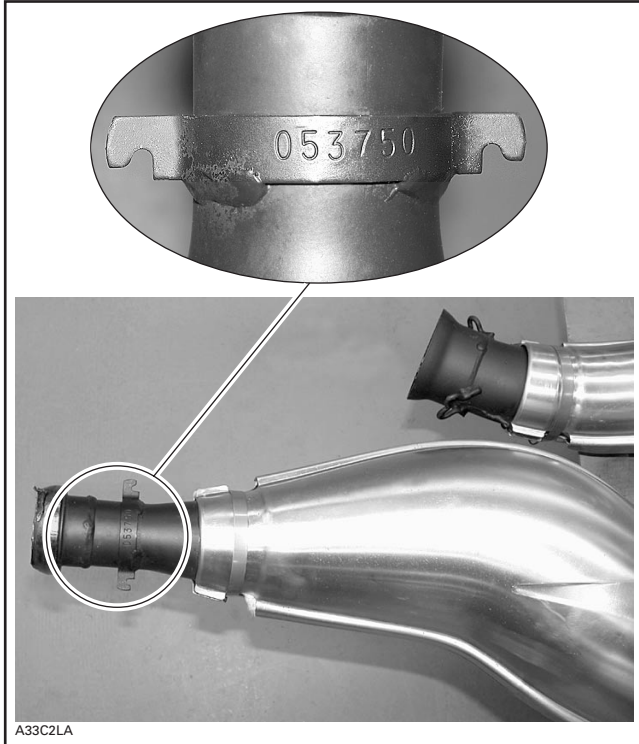

TYPICAL

Removal

Open hood and right side panel.

Remove:

- all exhaust springs **no. 1** using exhaust spring installer/remover (P/N 529 035 401)

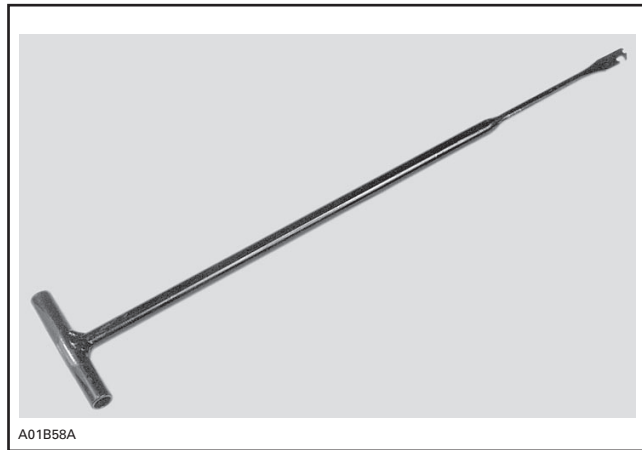

- tuned pipe **no. 2**
- exhaust gasket **no. 3** and **no. 4** if applicable.

Inspection

Check:

- tuned pipe shield for damages
- tuned pipe ends for cracks or damages.

Installation

Install doughnut shaped exhaust gasket **no. 3** with both of its notches aligned with Y-manifold protrusions.

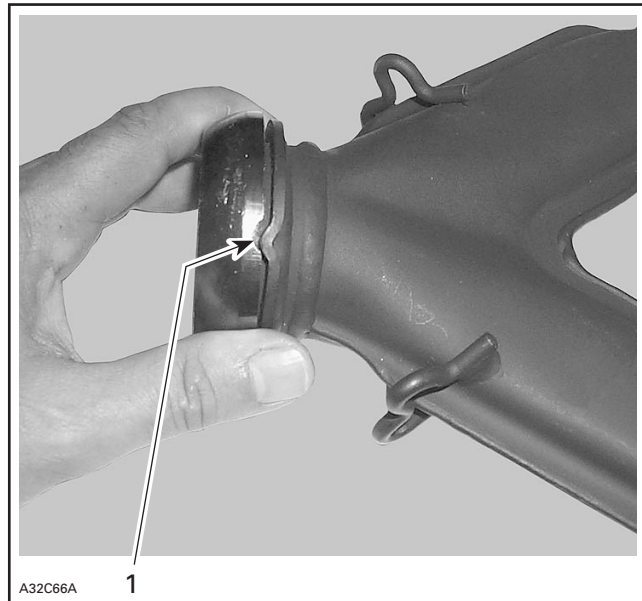

1. Align notches

If the gaskets are damaged, replace them.

Fan Cooled Engines

Apply RTV sealant (P/N 293 800 090) on gasket contact surfaces.

All Engines

Install all exhaust springs using exhaust spring installer/remover (P/N 529 035 401).

MANIFOLD

Removal

Remove:

- tuned pipe no. 2
- doughnut shaped exhaust gasket no. 3
- manifold screws no. 5

CAUTION: On engines with 6 mm (1/4 in) screws, heat screws for 30 seconds before loosening to prevent screw breakage.

- manifold no. 6
- gaskets no. 7.

Inspection

Check if the manifold is cracked or damaged. Replace if necessary.

Installation

Install the manifold with new gaskets.

Torque manifold screws no. 5.

NOTE: On liquid cooled engines, use the following tightening sequence.

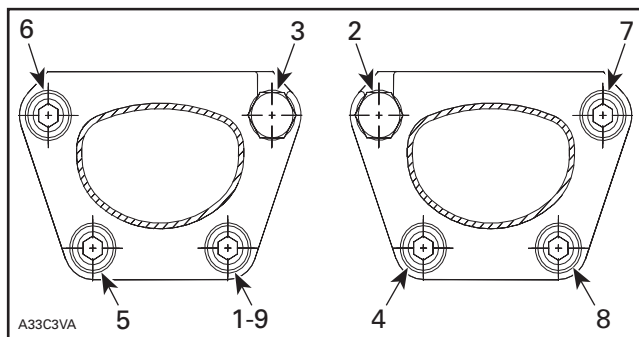

ENGINE	TORQUE
377/552/593	22 N•m (16 lbf•ft)
593 HO, 593 HO SDI and 793 HO	11 N•m (97 lbf•in)

Install tuned pipe.

MUFFLER

Identification

Each muffler is identified by a number. To use the proper muffler with the proper vehicle, check the number on the welded clamp at the end of muffler. This number depicts the 6 last numbers of BRP part number.



TYPICAL

Removal

Remove tuned pipe no. 2.

Disconnect the EGTS (Exhaust Gas Temperature Sensor) on SDI models.

Remove springs no. 8 retaining the muffler no. 9. Use exhaust spring installer/remover (P/N 529 035 401).

Remove the muffler.

Inspection

Check the muffler for cracks or other damages.

Refer to the COMPONENT INSPECTION, REPLACEMENT AND ADJUSTMENT section to verify the EGTS.

Installation

For installation, reverse the removal procedure.

ENGINE REMOVAL AND INSTALLATION

SERVICE TOOLS

Description	Part Number	Page
engine removal hook	529 035 829	69
pump	529 035 880	65
small hose pincher	295 000 076	60
spark plug lift ring	529 035 830	68

SERVICE PRODUCTS

Description	Part Number	Page
Loctite 243 (blue).....	293 800 060	63, 69

Section 03 ENGINES

Subsection 03 (ENGINE REMOVAL AND INSTALLATION)

Fan-Cooled Engines

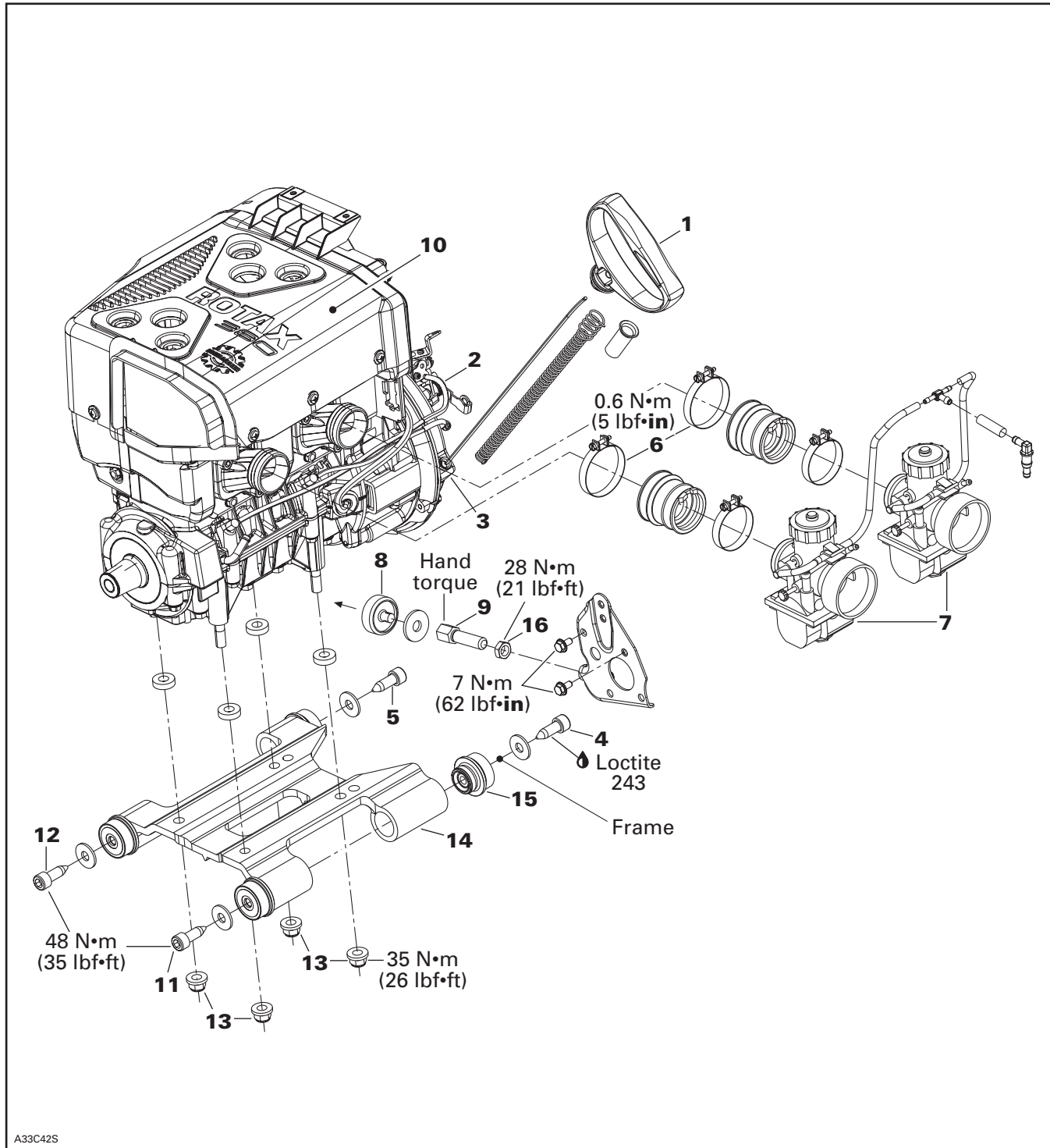

REMOVAL FROM VEHICLE

Vehicle and Engine Preparation

Place vehicle at workstation that will have access to an engine-lifting hoist. Then start with initial preparation of vehicle by doing the following.

Remove the RH and the LH side panels.

Disconnect BLACK (-) cable from battery, then the RED (+) cable.

WARNING

Always disconnect battery or starter cables exactly in the specified order, BLACK (-) cable first. It is recommended to disconnect electrical connections prior to disconnecting fuel lines.

From the front of vehicle

Remove tuned pipe and manifold, refer to EX-HAUST SYSTEM.

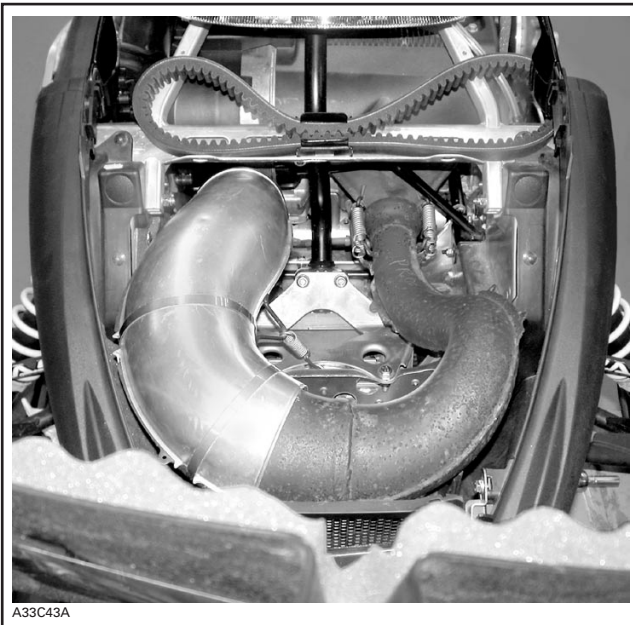

Disconnect starter cables.

On right side of vehicle, do the following:

Remove muffler.

Unfasten the screws retaining the air duct inlet, lift up the retaining tabs and remove the air duct inlet.

Unplug the magneto, the reverse, the trigger coil and the engine stop switch connectors.

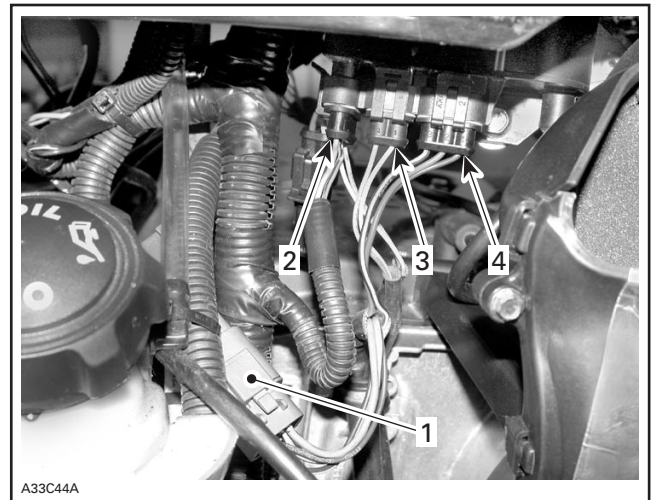

1. Magneto connector
2. Reverse connector
3. Trigger coil connector
4. Engine stop switch connector

On the reverse connector, disconnect the BLUE/YELLOW and the WHITE/YELLOW wires from the connector. To do this, remove the lock then using a small tool extract wires from connector.

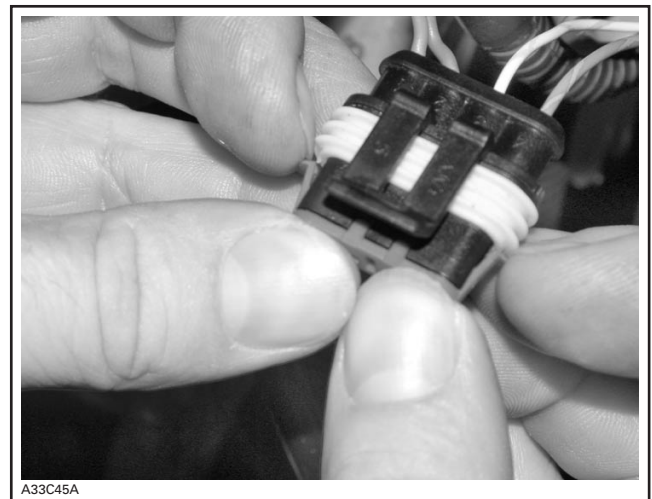

MOVE ASIDE BOTH TABS TO REMOVE LOCK

Remove the rewind starter handle **no. 1**.

Unscrew oil pump **no. 2** from rewind starter housing **no. 3**.

Section 03 ENGINES

Subsection 03 (ENGINE REMOVAL AND INSTALLATION)

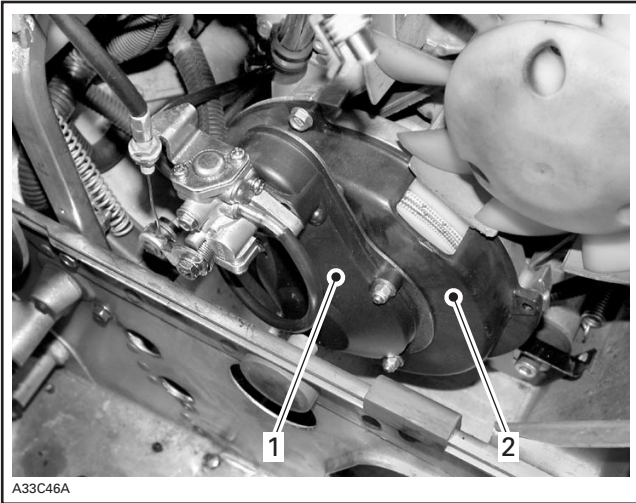

552 ENGINE SHOWN

1. Oil pump
2. Rewind starter housing

Unplug both outlet hoses from oil pump.

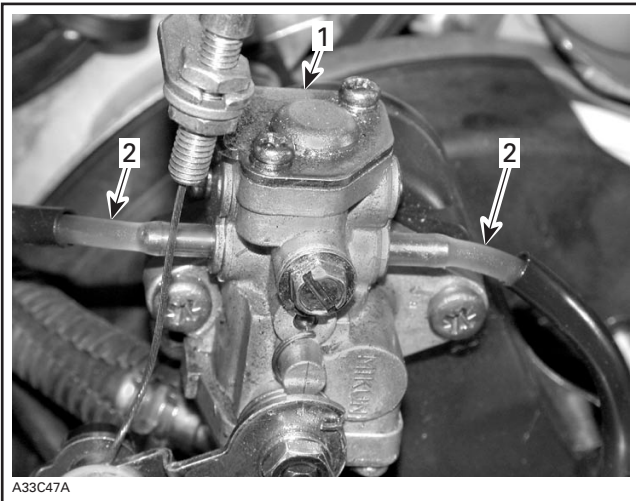

1. Oil pump
2. Outlet hoses

Install a small hose pincher (P/N 295 000 076) on the inlet oil line and disconnect it from oil pump. Catch any spillage.

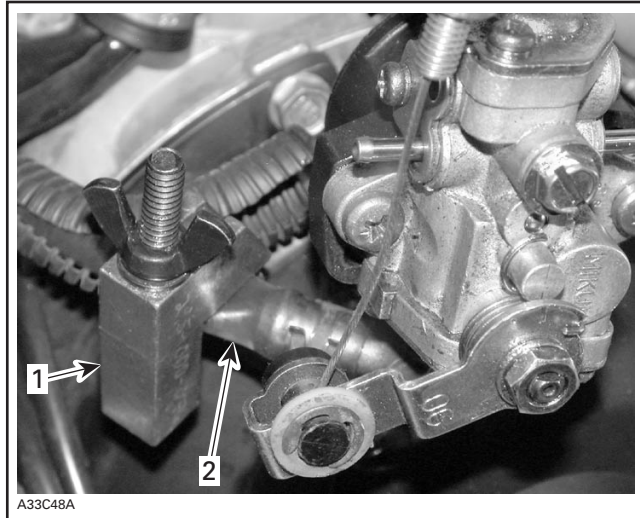
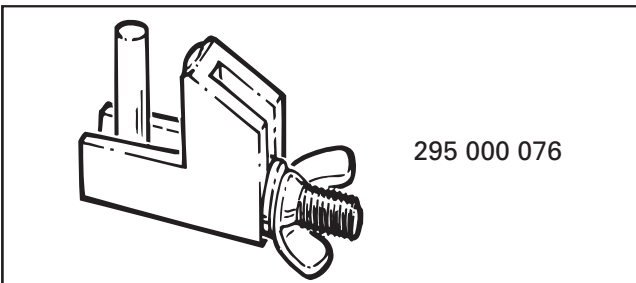

1. Hose pincher
2. Inlet oil line

Unscrew engine support bolts no. 4 and no. 5.

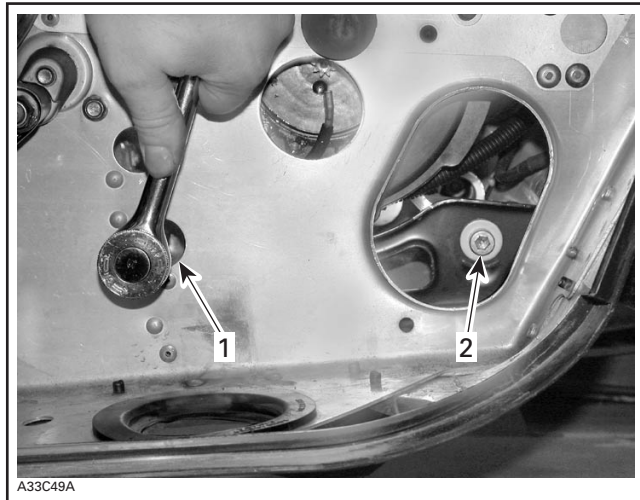

1. Rear engine support bolt location
2. Front engine support bolt

On left side of vehicle, do the following:

Remove drive and driven pulleys. Refer to the appropriate section.

Remove air box.

Unscrew carburetor clamps no. 6 then separate the carburetors no. 7 from the engine.

Section 03 ENGINES
Subsection 03 (ENGINE REMOVAL AND INSTALLATION)

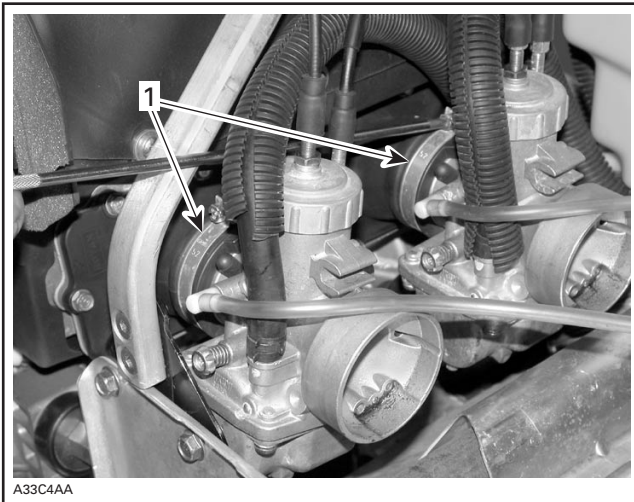

1. Carburetor clamps

Unscrew and remove the engine stopper. Do not remove rubber end **no. 8** only, unscrew the screwed rod **no. 9** completely.

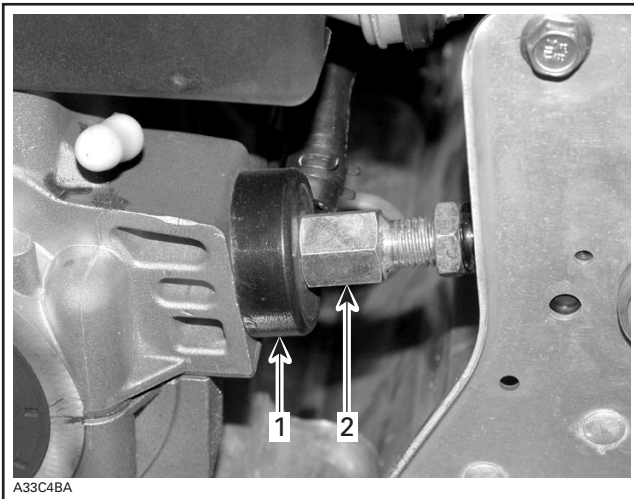

1. Rubber end
2. Screwed rod

Remove the impulse line from crankcase.
Disconnect the spark plug cables.
Remove front brace.



1. Front brace

Unscrew the rear brace.

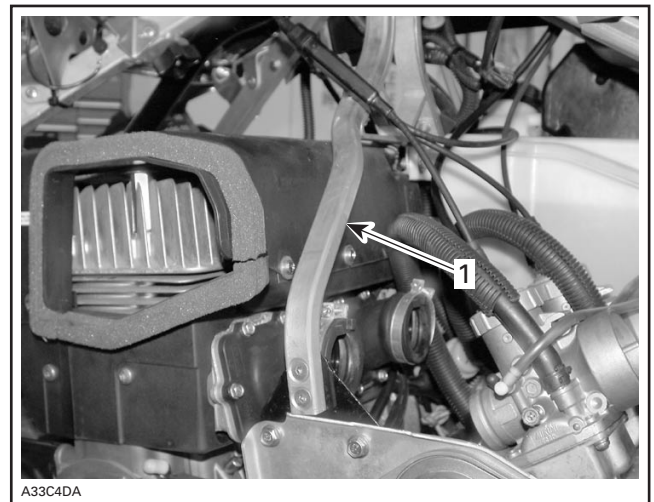

1. Rear brace

Remove the cylinder cowl **no. 10**.

Section 03 ENGINES

Subsection 03 (ENGINE REMOVAL AND INSTALLATION)



Remove the engine support bolts no. 11 and no. 12.

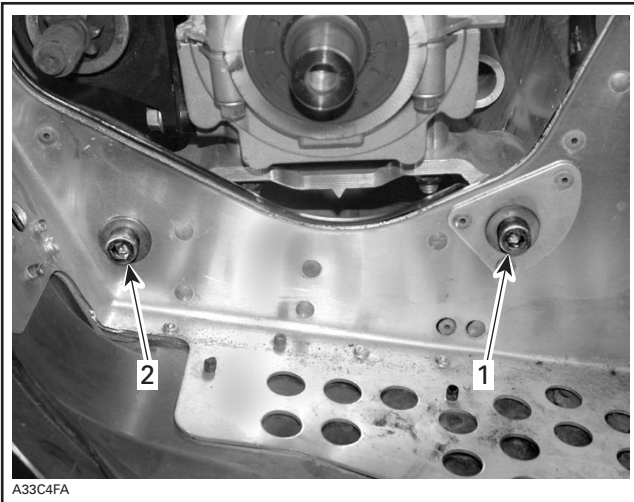

1. Rear engine support bolt
2. Front engine support bolt

Remove headlamp adjusting knob from its support.

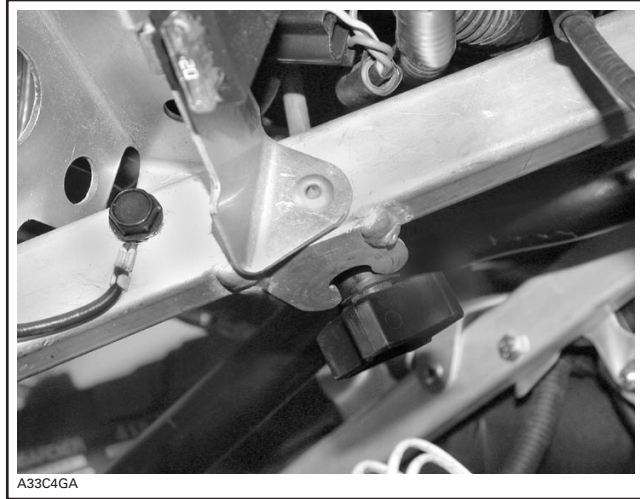

Install the homemade lifting tool.

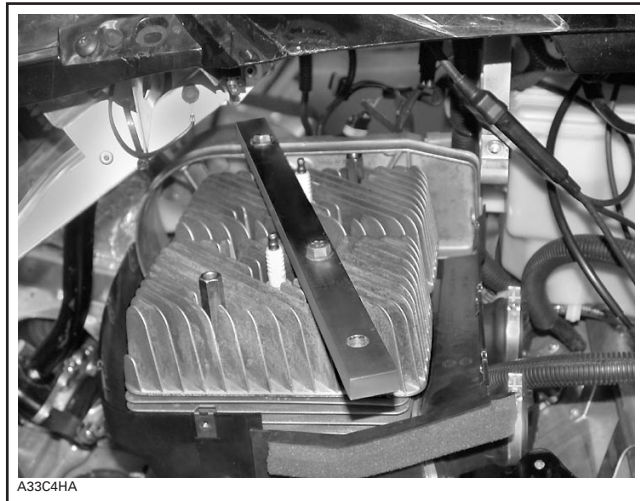

Use the following illustration to make the tool.

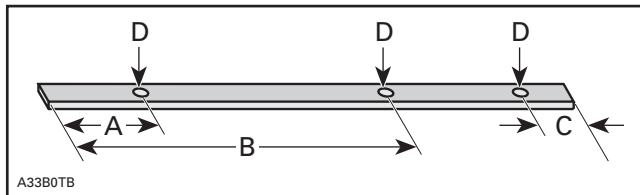

FLAT BAR 152 X 25.4 X 13 MM (16 X 1 X 1/2 IN)

- A. 51 mm (2 in)
- B. 260 mm (10-1/4 in)
- C. 38 mm (1-1/2 in)
- D. Diameter: 13 mm (1/2 in)

Lift up the engine.

Unscrew the nuts no. 13 retaining engine support no. 14 to engine.

Section 03 ENGINES

Subsection 03 (ENGINE REMOVAL AND INSTALLATION)

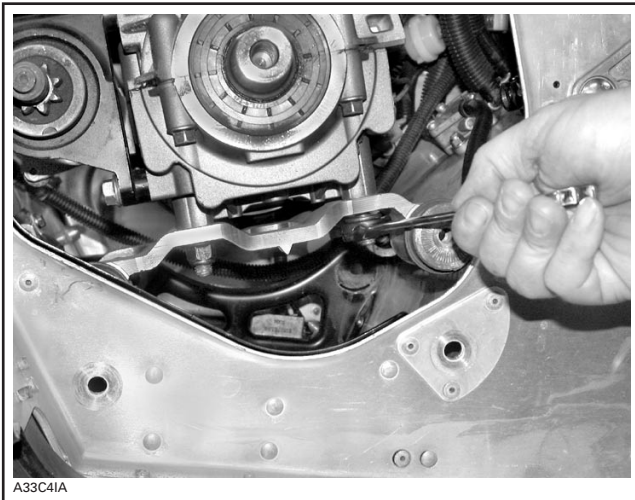

Torque engine support bolts to 48 N•m (35 lbf•ft).
Hand torque engine stopper **no. 9** then torque its nut **no. 16** to 50 N•m (37 lbf•ft).

Reinstall all removed parts by using the appropriate component/system reinstallation procedures described in this shop.

Remove the support from engine and lower it in frame.

Remove engine from vehicle.

INSPECTION

Check if engine support **no. 14** is cracked, bent or otherwise damaged. Replace if necessary.

Check rubber mounts **no. 15** on engine support. Replace them if brittle, cracked or otherwise damaged.

INSTALLATION

To install engine in vehicle, reverse the removal procedure. However, pay attention to the following.

Install engine support under engine then torque engine support nuts to 35 N•m (26 lbf•ft).

Before installing engine support bolts, apply Loctite 243 (blue) (P/N 293 800 060) as shown in the following illustration.

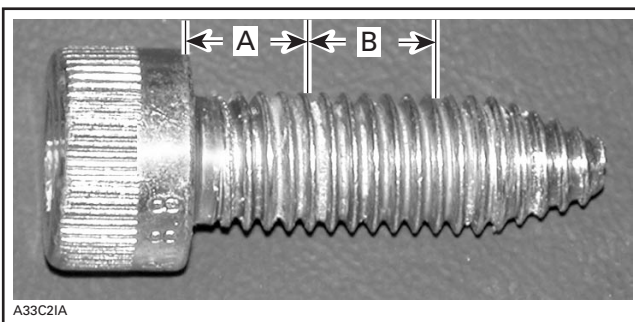

A. Do not apply Loctite in this area, ± 10 mm (.39 in)
B. Loctite area, ± 8 mm (.31 in)

Section 03 ENGINES

Subsection 03 (ENGINE REMOVAL AND INSTALLATION)

Liquid-Cooled Engines

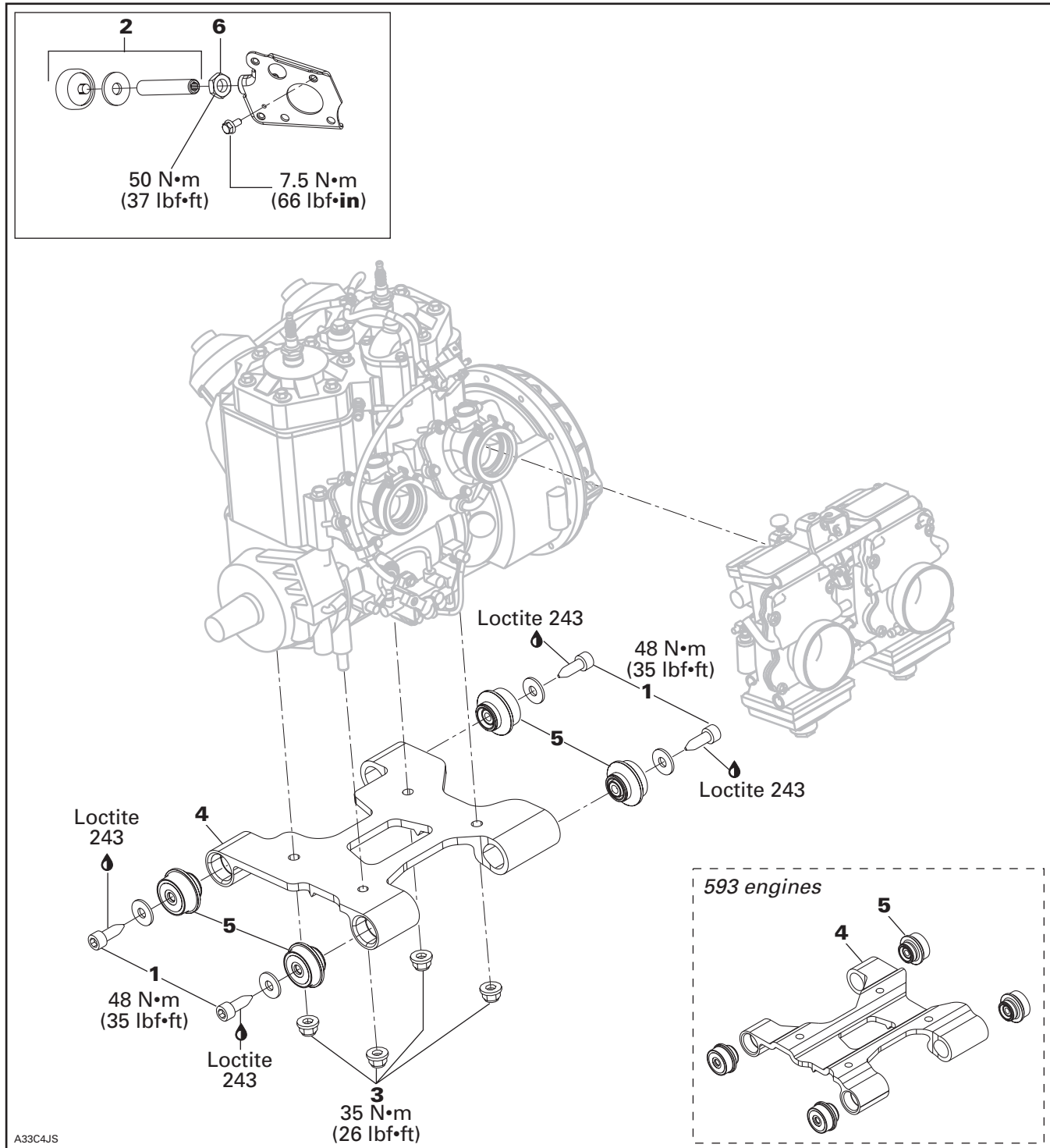

REMOVAL FROM VEHICLE

Vehicle and Engine Preparation

Place vehicle at workstation that will have access to an engine-lifting hoist. Then start with initial preparation of vehicle by doing the following.

Remove windshield.

Remove the RH side panel.

Disconnect BLACK (-) cable from battery, then the RED (+) cable.

WARNING

Always disconnect battery or starter cables exactly in the specified order, BLACK (-) cable first. It is recommended to disconnect electrical connections prior to disconnecting fuel lines.

On SDI models, release the fuel pressure of the system. Refer to COMPONENT INSPECTION AND ADJUSTMENT.

From the Front of Vehicle

Remove tuned pipe and manifold, refer to EXHAUST SYSTEM.



Remove starter.

NOTE: Remove BLACK starter cable from vehicle, not from starter.

On right side of vehicle, do the following:

Remove muffler.

Drain coolant reservoir.

Unplug from the coolant reservoir the hose going to the engine.



1. Coolant hose between reservoir and engine

Using pump (P/N 529 035 880), drain maximum coolant from hose and engine.



Section 03 ENGINES

Subsection 03 (ENGINE REMOVAL AND INSTALLATION)

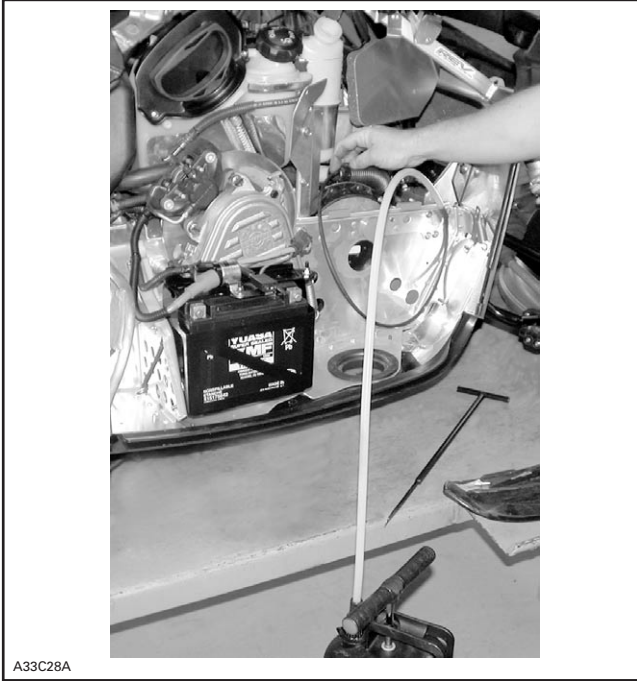

Unplug magneto and trigger coil connectors.

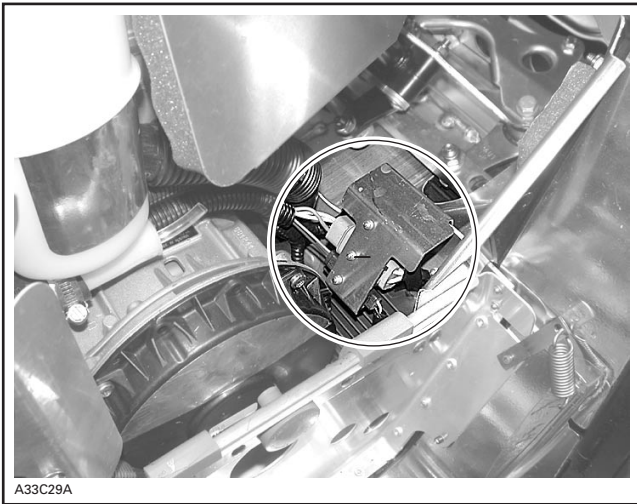

Remove rewind starter handle.

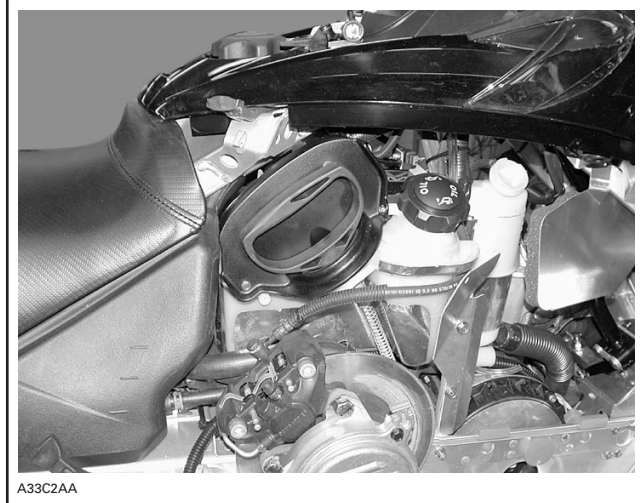

Unplug heater carburetor hose from coolant reservoir.

Unscrew oil injection reservoir then separate coolant reservoir.

On left side of vehicle, do the following:

Remove:

- LH side panel
- tool box
- belt guard
- belt drive
- drive pulley (refer to DRIVE PULLEY)
- air intake silencer (unplug ATS (Air Temperature Sensor) connector).

NOTE: On SDI models, unplug APS (Air Pressure Sensor) and ATS (Air Temperature Sensor) connectors.

Unplug coolant hose between engine and carburetor or throttle body.



Section 03 ENGINES
Subsection 03 (ENGINE REMOVAL AND INSTALLATION)

Unplug RAVE valve line from solenoid.

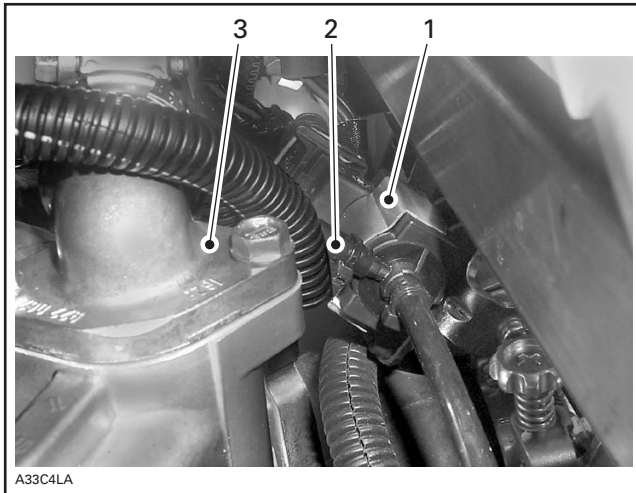

1. Solenoid
2. RAVE valve line
3. Thermostat housing

Separate carburetors or throttle body from engine.
Unplug coolant hose located between cylinder head and radiator.

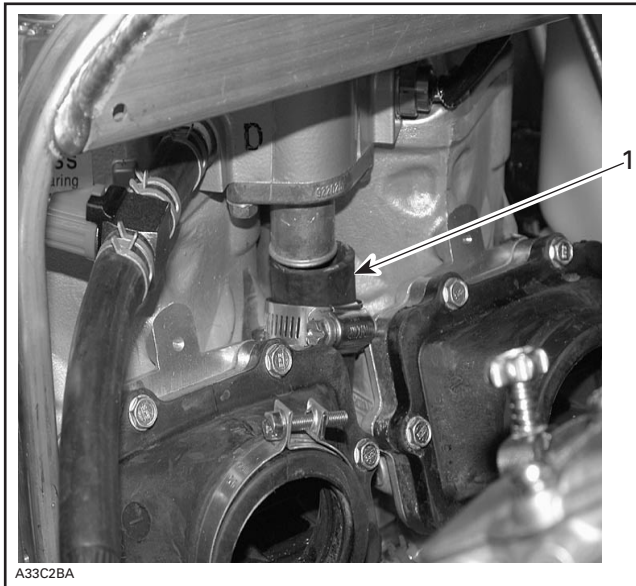

1. Coolant hose between cylinder head and radiator

Remove reed valves with their gaskets.



- TYPICAL — 793 HO ENGINE TYPE SHOWN*
1. Reed valve

Unplug magneto connector from MPEM.
Detach oil pump cable from oil pump.

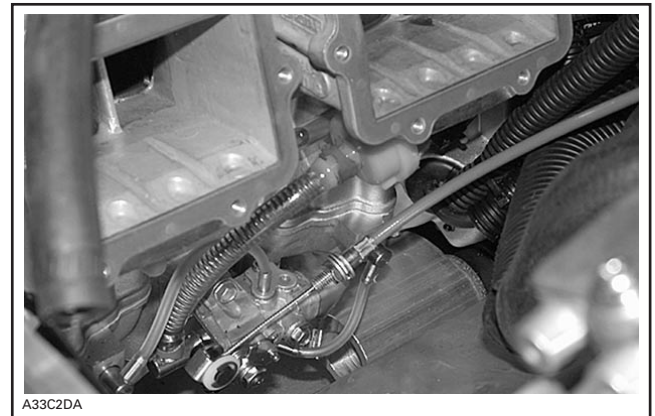

Unplug spark plug cables.
Cut all ties retaining the knock sensor wire and disconnect its connector.

Section 03 ENGINES

Subsection 03 (ENGINE REMOVAL AND INSTALLATION)



1. Knock sensor connector

Detach upper thermostat hose from thermostat housing.

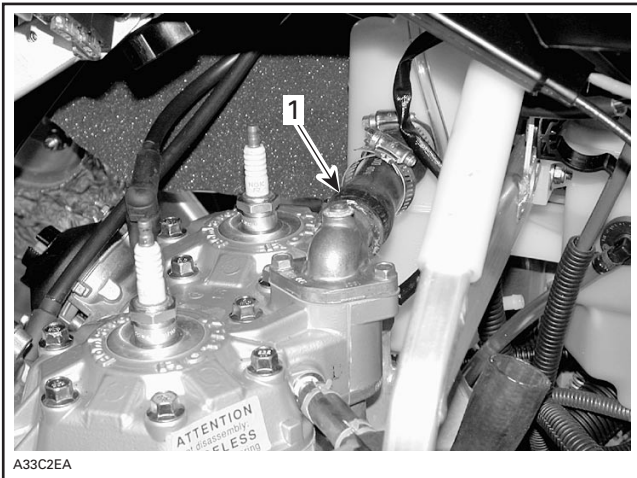

1. Remove this hose

Disconnect temperature sensor connectors.

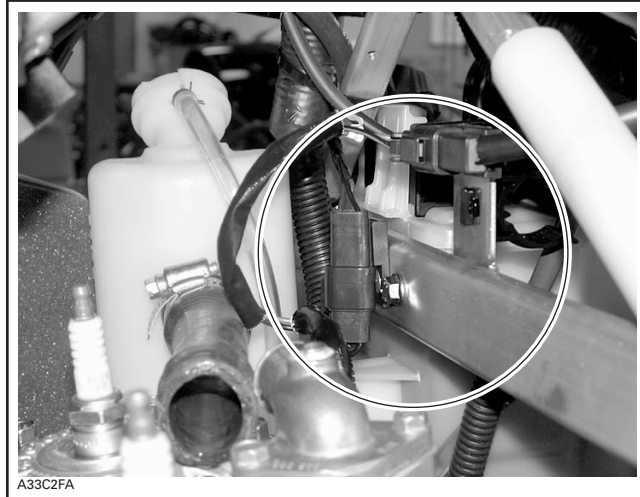

Remove spark plugs and install the spark plug lift ring (P/N 529 035 830) at the farthest spark plug hole.

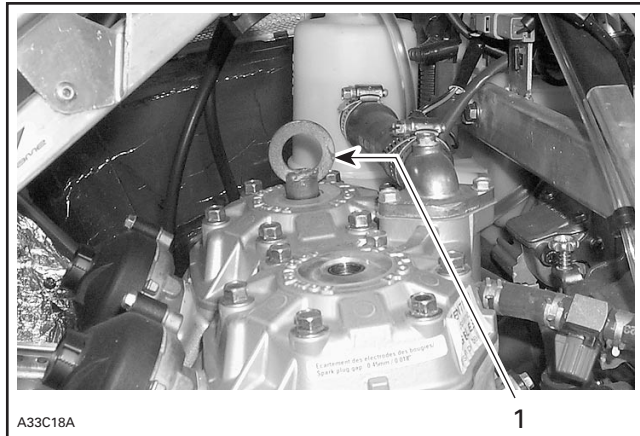

1. Spark plug lift ring

Remove RAVE valves.

Unscrew engine support bolts no. 1.

Section 03 ENGINES

Subsection 03 (ENGINE REMOVAL AND INSTALLATION)

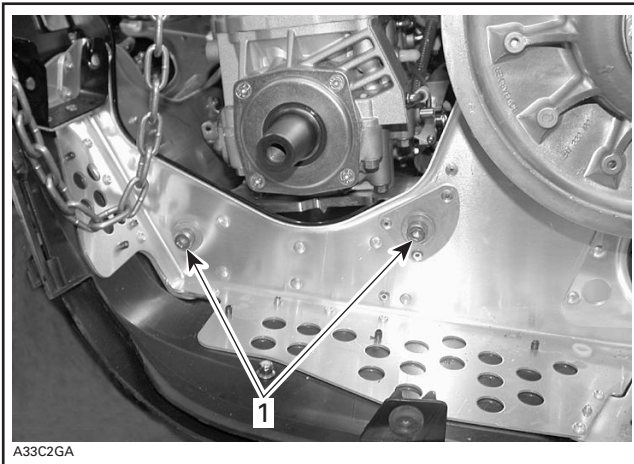

LEFT SIDE OF VEHICLE
1. Engine support bolts

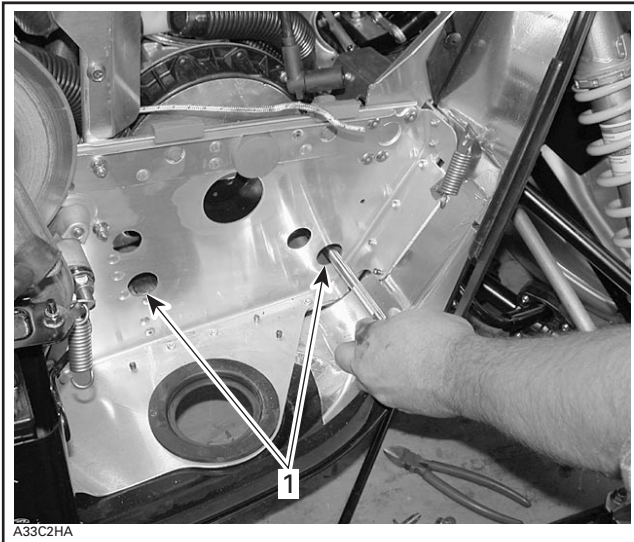

RIGHT SIDE OF VEHICLE
1. Holes to reach engine support bolts

Unscrew the engine stopper **no. 2** completely.
Lift the engine a little then unplug oil pump hoses and the crankcase vent hose.

On **SDI models**, disconnect all engine connectors (CPS, WTS, KS and injectors).

Lift and slide out engine using the engine removal hook (P/N 529 035 829).



Unscrew engine support nuts **no. 3** then separate support **no. 4** from engine.

INSPECTION

Check if engine support **no. 4** is cracked, bent or otherwise damaged. Replace if necessary.

Check rubber mounts **no. 5** on engine support. Replace them if brittle, cracked or otherwise damaged.

INSTALLATION

To install engine in vehicle, reverse the removal procedure. However, pay attention to the following.

Install engine support under engine then torque engine support nuts to 35 N•m (26 lbf•ft).

Before installing engine support bolts **no. 1**, apply Loctite 243 (blue) (P/N 293 800 060) as shown in the following illustration.

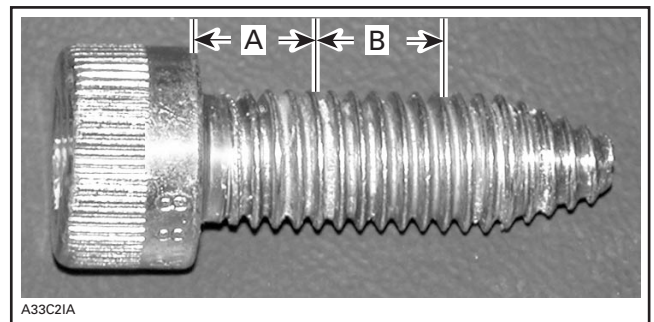

A. Do not apply Loctite in this area, ± 10 mm (.39 in)
B. Loctite area, ± 8 mm (.31 in)

Torque engine support bolts to 48 N•m (35 lbf•ft).

Hand torque engine stopper **no. 2** then torque its nut **no. 6** to 50 N•m (37 lbf•ft).

Reinstall all removed parts by using the appropriate component/system reinstallation procedures described in this shop.

MAGNETO SYSTEM

SERVICE TOOLS

Description	Part Number	Page
crankshaft protector	420 876 557	77
magneto puller.....	529 035 547	77
puller ring.....	420 876 080	76

SERVICE PRODUCTS

Description	Part Number	Page
Loctite 243 (blue).....	293 800 060	77-78
silicone dielectric grease	293 550 004	77

Section 03 ENGINES

Subsection 04 (MAGNETO SYSTEM)

377 and 552 Engines

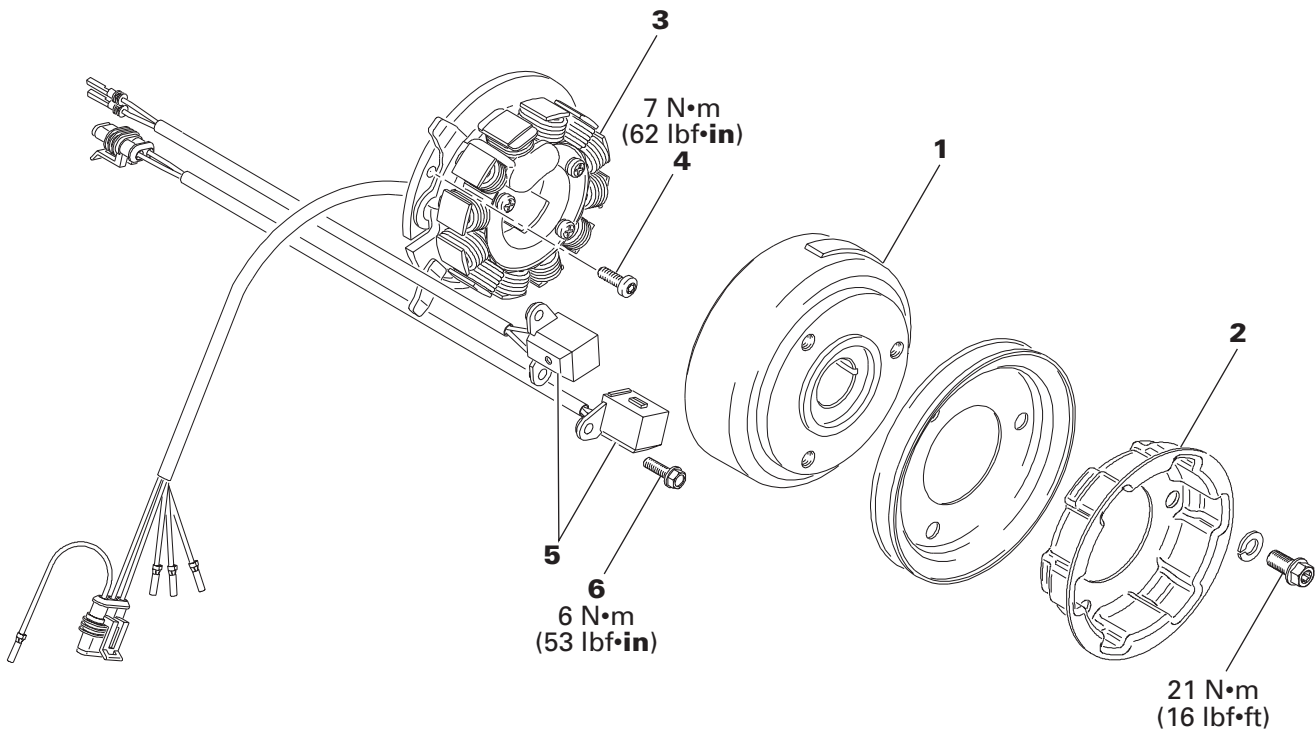

A33C3XS

Section 03 ENGINES
Subsection 04 (MAGNETO SYSTEM)

593 Engines

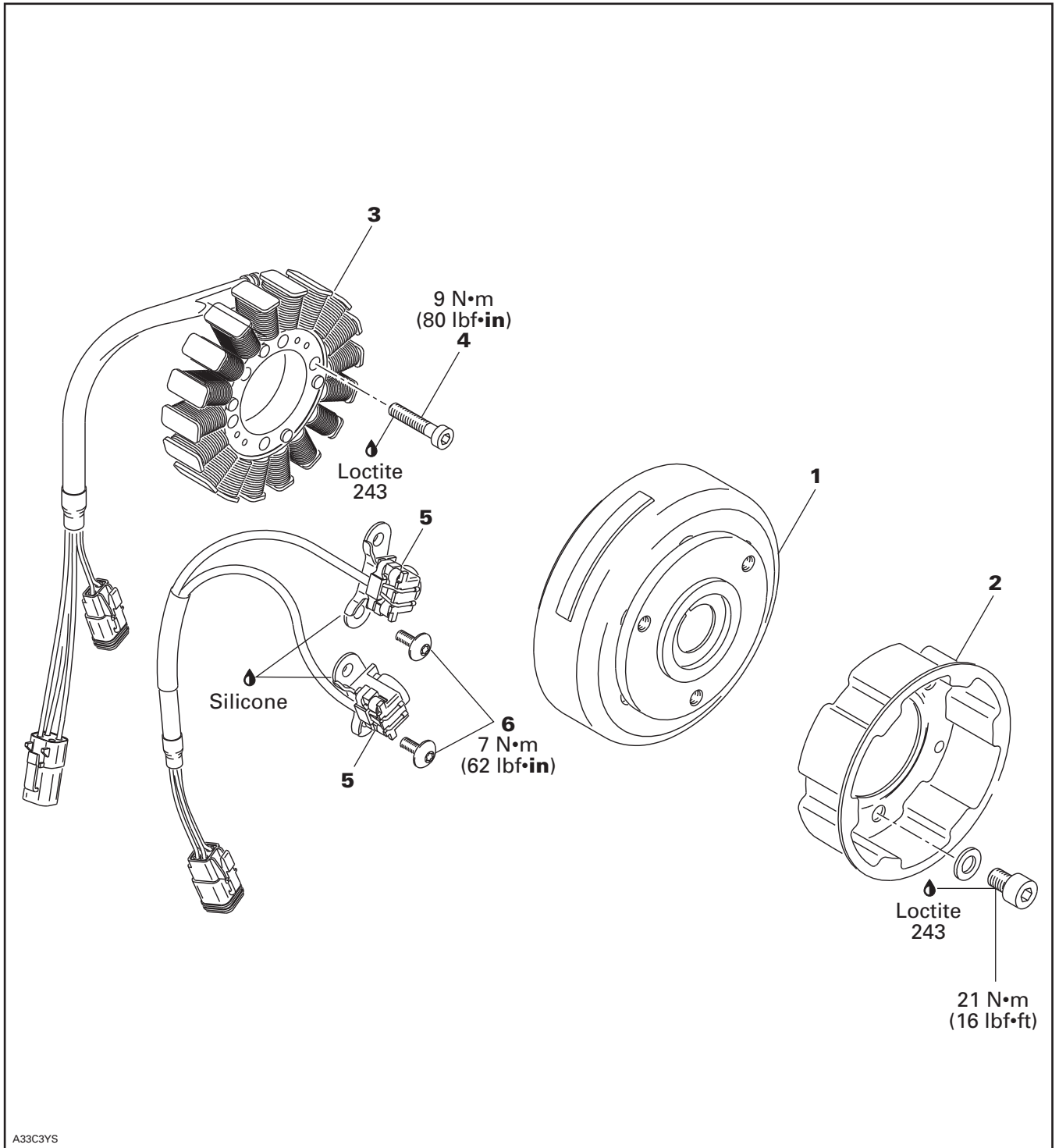

Section 03 ENGINES

Subsection 04 (MAGNETO SYSTEM)

593 HO and 793 HO Engines

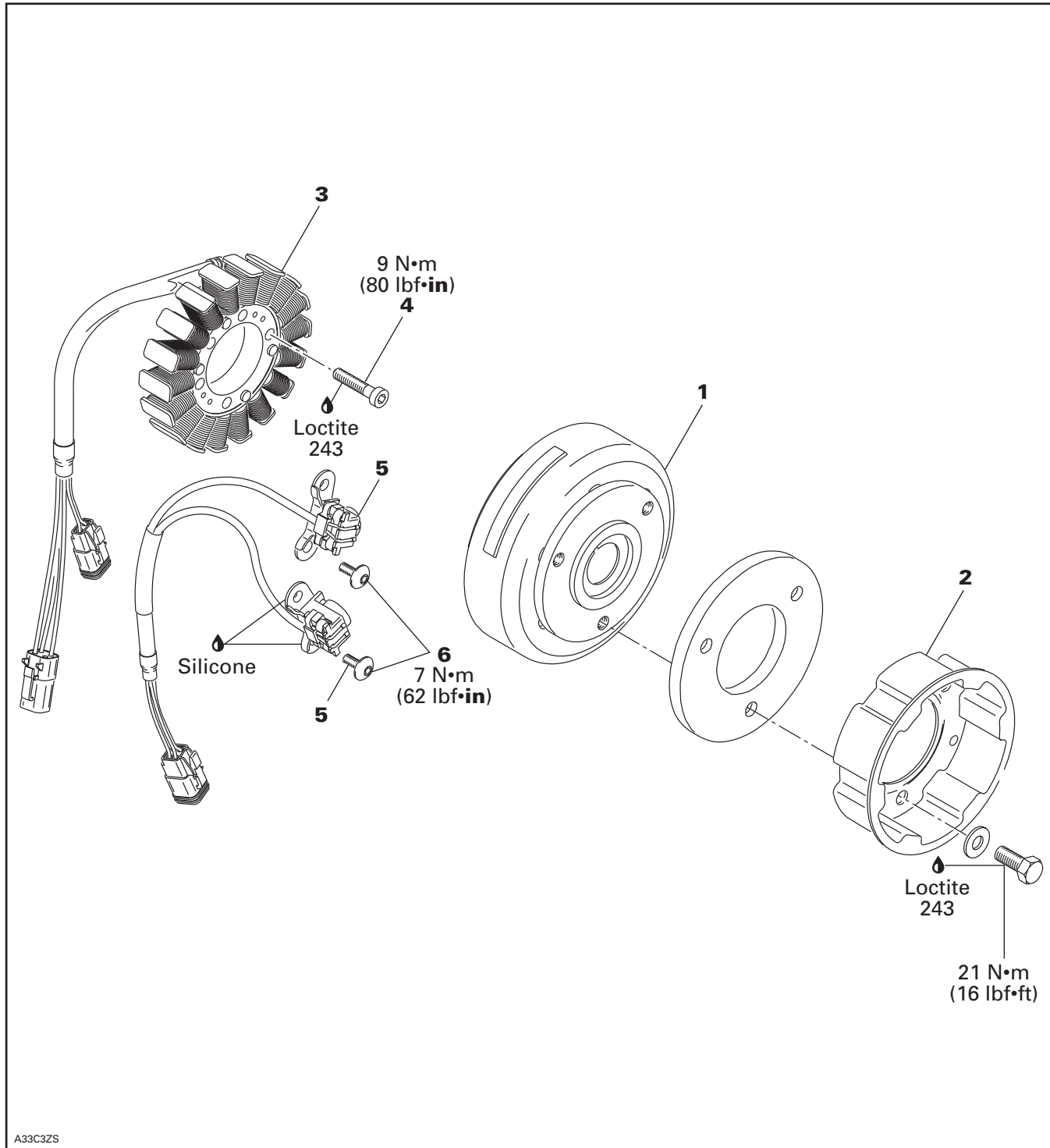

Section 03 ENGINES
Subsection 04 (MAGNETO SYSTEM)

593 HO SDI Engines

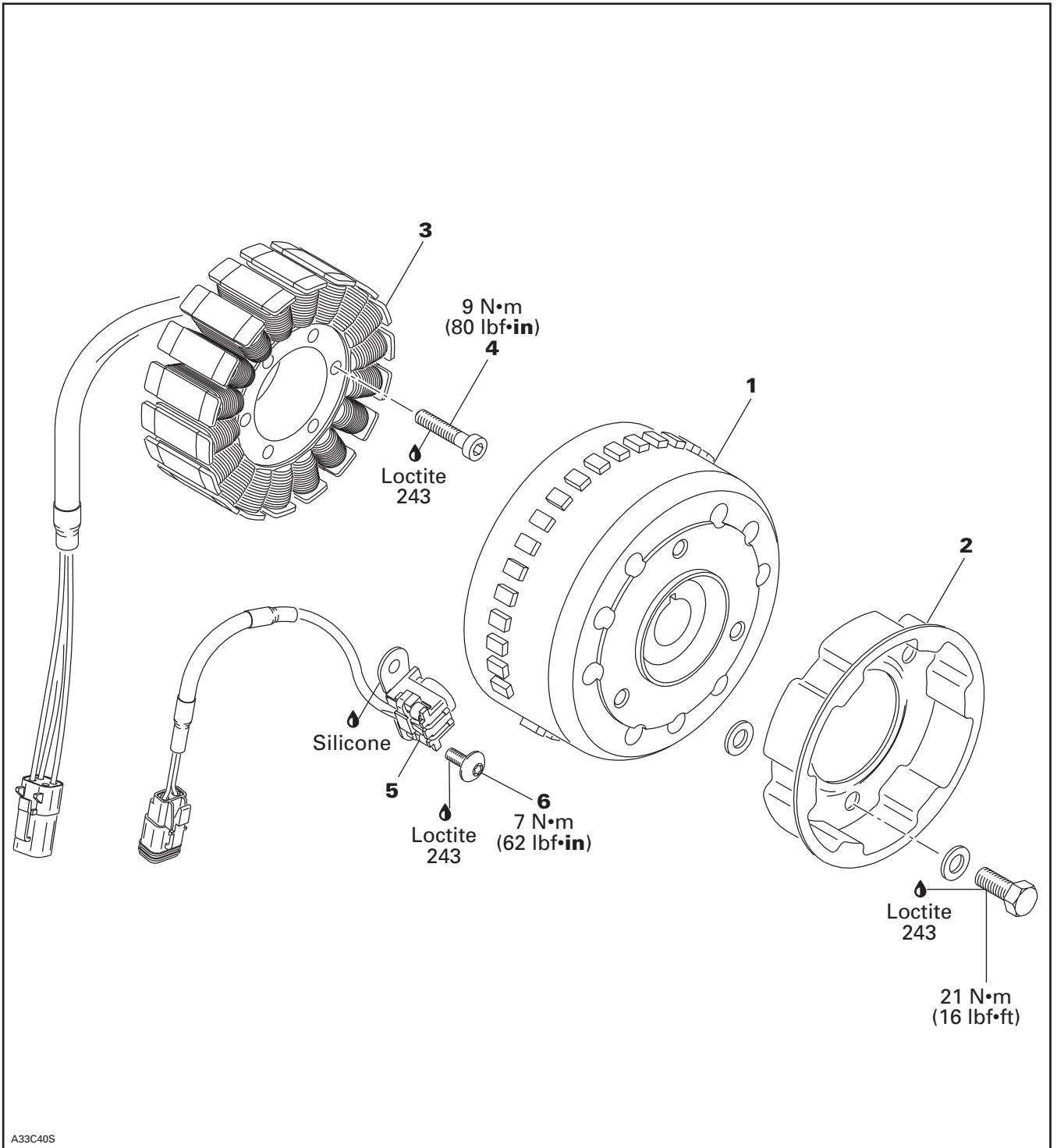

Section 03 ENGINES

Subsection 04 (MAGNETO SYSTEM)

GENERAL

NOTE: The following procedures can be done without removing the engine. To facilitate magneto removal, hold drive pulley with the appropriate tool.

During assembly/installation, use the torque values and service products as in the exploded views.

Clean threads before applying a threadlocker. Refer to SELF-LOCKING FASTENERS and LOCTITE APPLICATION at the beginning of this manual for complete procedure.

WARNING

Torque wrench tightening specifications must strictly be adhered to.

Locking devices (e.g.: locking tabs, elastic stop nuts, self-locking fasteners, etc.) must be installed or replaced with new ones where specified. If the efficiency of a locking device is impaired, it must be renewed.

MAGNETO FLYWHEEL

Cleaning

Clean all metal components in a non-ferrous metal cleaner.

CAUTION: Clean magneto flywheel using only a clean cloth.

Removal

To gain access to magneto flywheel **no. 1** assembly, remove the following parts as needed on different engines:

- tuned pipe and muffler
- rewind starter
- starting pulley **no. 2**.

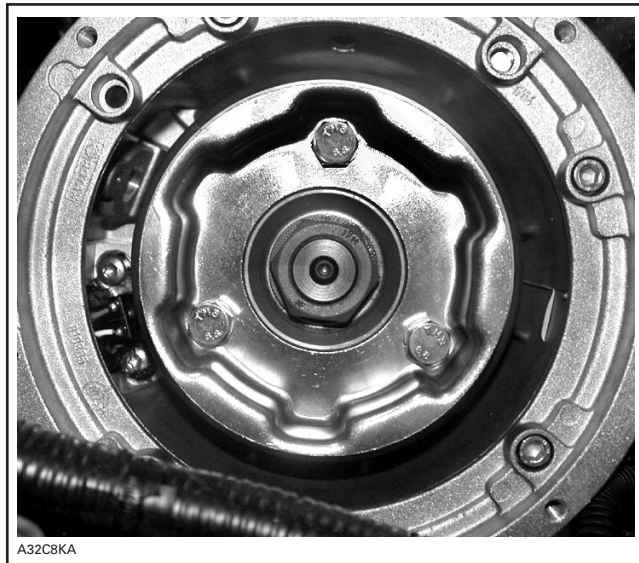

TYPICAL

Remove the connecting flange retaining the rewind starter to the engine housing.

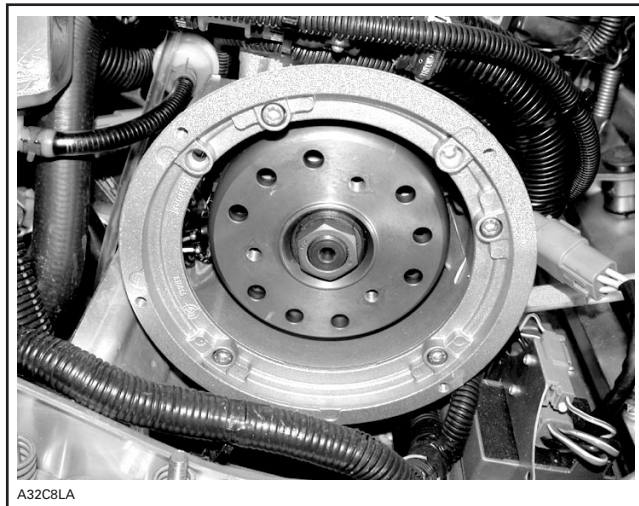

TYPICAL

- Install the puller ring (P/N 420 876 080) in magneto housing opening.

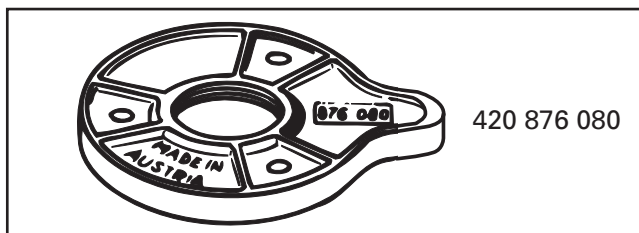

Section 03 ENGINES

Subsection 04 (MAGNETO SYSTEM)

CAUTION: Use only M8 x 20 mm screws to bolt puller to magneto flywheel. When a counterweight is installed on magneto flywheel use M8 x 30 mm screws.

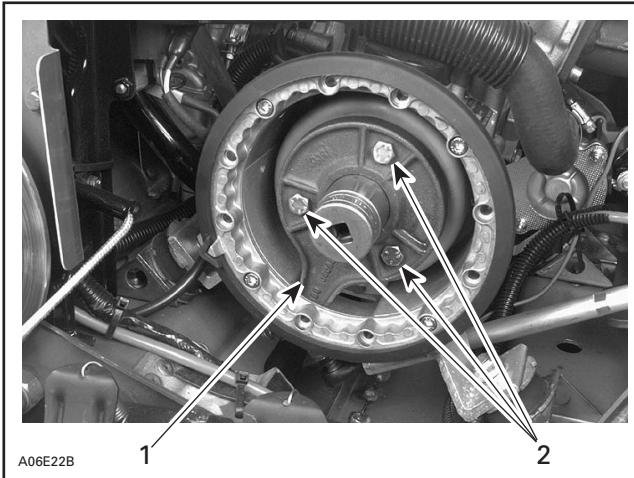

TYPICAL

1. Tab in magneto housing opening
2. M8 screws

- Remove magneto flywheel nut, using a 30 mm socket machined to 40 mm (1.580 in) outside diameter by 16 mm (5/8 in) long.

NOTE: To correctly remove a threadlocked fastener, first tap on the fastener to break threadlocker bond. This will avoid thread breakage.

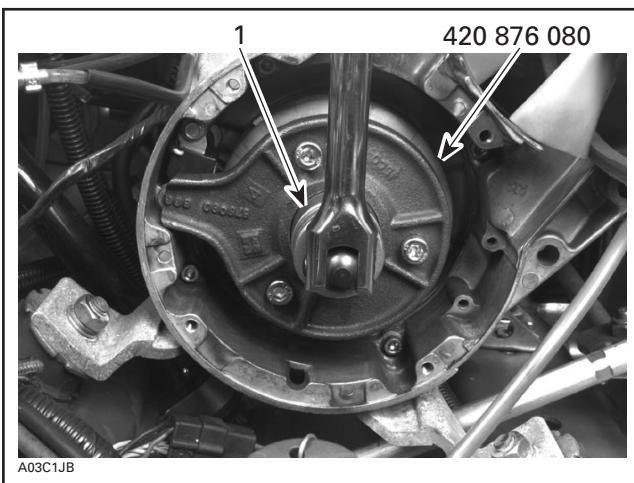

TYPICAL

1. 30 mm socket

To remove magneto flywheel, install the crankshaft protector (P/N 420 876 557) on crankshaft end. Screw the magneto puller (P/N 529 035 547) into puller ring.

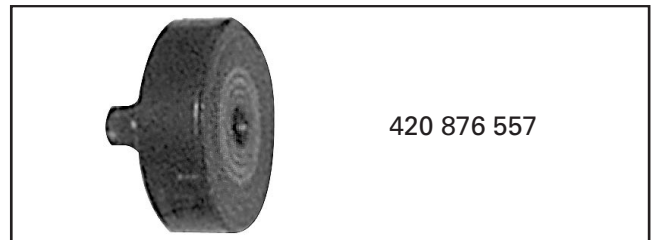
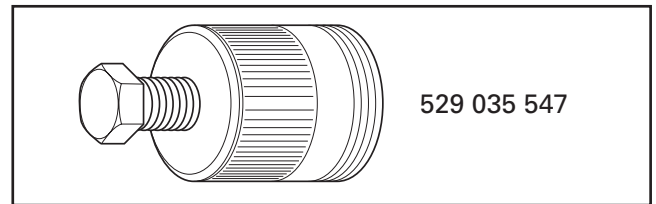

Tighten puller bolt and at the same time, tap on bolt head using a hammer to release magneto flywheel from its taper.

Installation

Clean crankshaft extension (taper) and apply Loctite 243 (blue) (P/N 293 800 060) on taper, then position Woodruff key, magneto flywheel **no. 1** and lock washer on crankshaft.

Clean magneto flywheel nut threads and apply Loctite 243 (blue) (P/N 293 800 060) then tighten nut.

ENGINES	TORQUE
377 and 552	105 N•m (77 lbf•ft)
593, 593 HO, 593 HO SDI and 793 HO Power Tek	125 N•m (92 lbf•ft)

At reassembly coat all electric connections except Deutsch housings (waterproof housing) with silicone dielectric grease (P/N 293 550 004) to prevent corrosion or moisture penetration.

CAUTION: Do not use silicone «sealant», this product will corrode contacts. Do not apply silicone dielectric grease on any Deutsch waterproof housing otherwise housing seal will be damaged.

Ignition Timing

Check as described in IGNITION TIMING.

Section 03 ENGINES

Subsection 04 (MAGNETO SYSTEM)

STATOR

Inspection

Always check stator **no. 3** before changing it. Refer to CHARGING SYSTEM.

Cleaning

Clean all metal components in a non-ferrous metal cleaner.

CAUTION: Clean stator using only a clean cloth.

Removal

Remove:

- magneto flywheel **no. 1**
- all Allen socket screws **no. 4** retaining stator to magneto housing
- grommet from crankcase where CPS/trigger coils **no. 5** and stator wires exit magneto housing.

Unplug the CPS/trigger coil connectors and pull the wires through the grommet location.

NOTE: To pass the stator connector into the grommet location it is necessary to pass the CPS/trigger coil connector first.

Unplug the stator connector and remove the stator **no. 3**.

Installation

Insert the stator connector into crankcase grommet then the CPS/trigger coil connector(s).

Install the grommet on crankcase

Position stator **no. 3** so that its wire protectors are over crankcase recess.

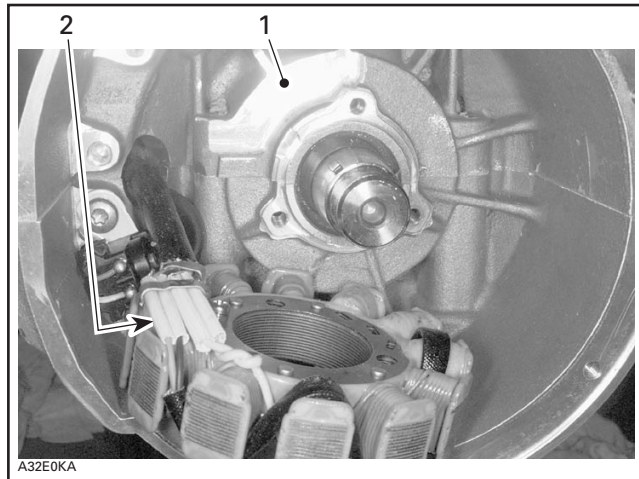

1. Crankcase recess
2. Wire protectors

NOTE: During installation, make sure the stator harness is located on the left side.

Apply Loctite 243 (blue) (P/N 293 800 060) on threads of stator screws then torque them to 9 N•m (80 lbf•in).

Reinstall all other removed parts.

CPS/TRIGGER COIL

Inspection

Always check CPS or trigger coils before changing it. Refer to IGNITION SYSTEM.

Removal

NOTE: Always check CPS or trigger coils **no. 5** before changing them. Refer to OVERVIEW section.

To replace the CPS or the trigger coil(s), remove or disconnect the following:

- magneto flywheel **no. 1**
- air intake silencer to allow an access to the CPS/trigger coil connectors (if necessary)
- trigger coil connector housing(s)
- grommet from crankcase where CPS/trigger coil wire(s) exit(s) magneto housing
- retaining screws **no. 6**
- CPS or trigger coil(s) and carefully pull wires.

Installation

For installation, reverse the removal procedure.

Section 03 ENGINES
Subsection 04 (MAGNETO SYSTEM)

NOTE: It is important to remove the old silicon at CPS/trigger coil location then apply new silicon. Screw CPS/trigger coil then stick the CPS/trigger coil wires in the silicon.

TOP END

SERVICE TOOLS

Description	Part Number	Page
bearing heater.....	529 035 969	86, 105
centering tool.....	529 009 100	87
piston circlip installer	529 035 561	87
piston circlip installer	529 035 686	89, 106
piston pin puller	529 035 503	87
rubber pad	529 023 400	84, 101

SERVICE PRODUCTS

Description	Part Number	Page
Loctite 243.....	293 800 060	107
Loctite 518.....	293 800 038	90, 107
Loctite Chisel.....	413 708 500	84, 98
sealing compound Drei Bond	420 297 906	104

Section 03 ENGINES
Subsection 05 (TOP END)

377 Engine

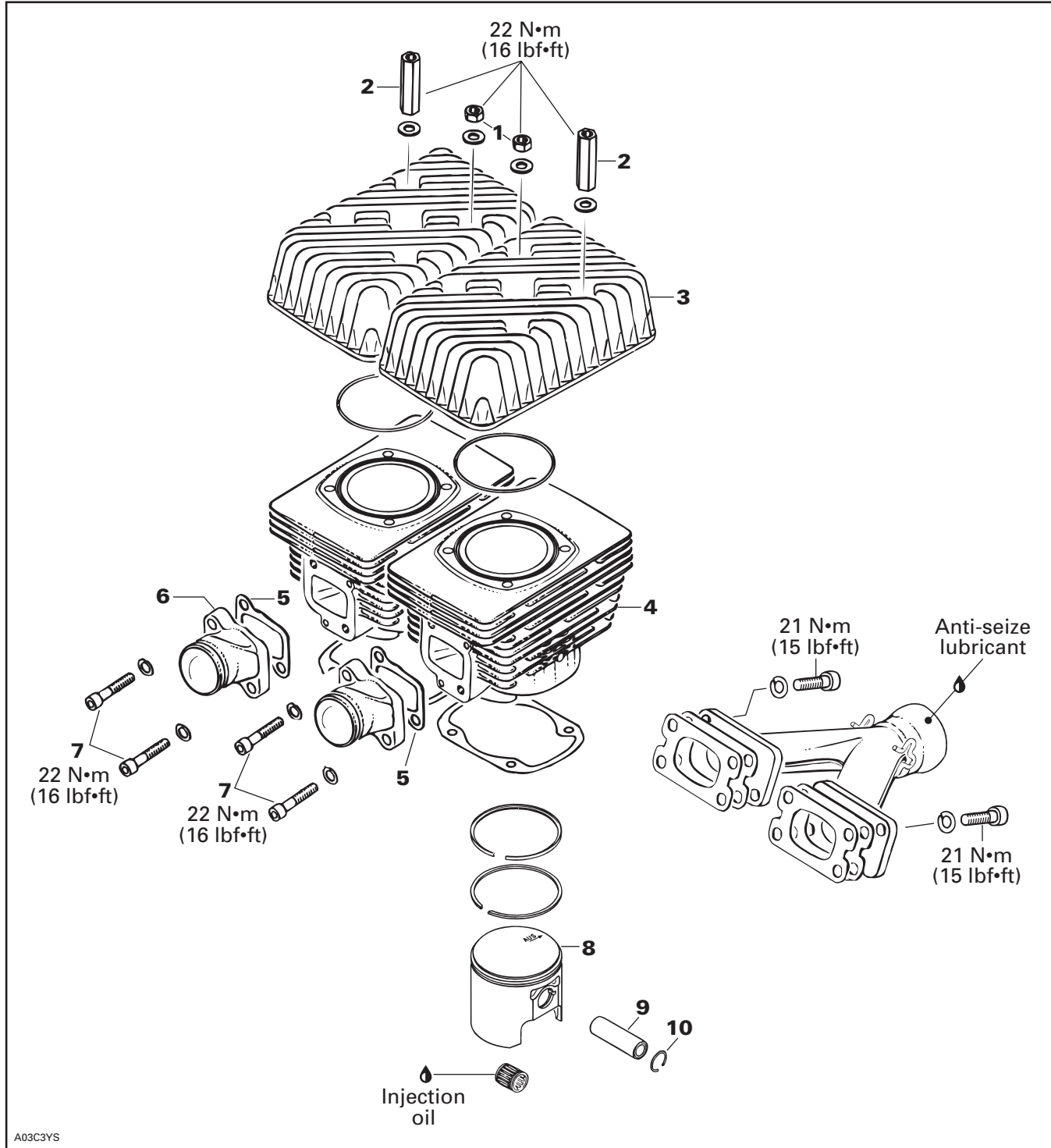

552 Engine

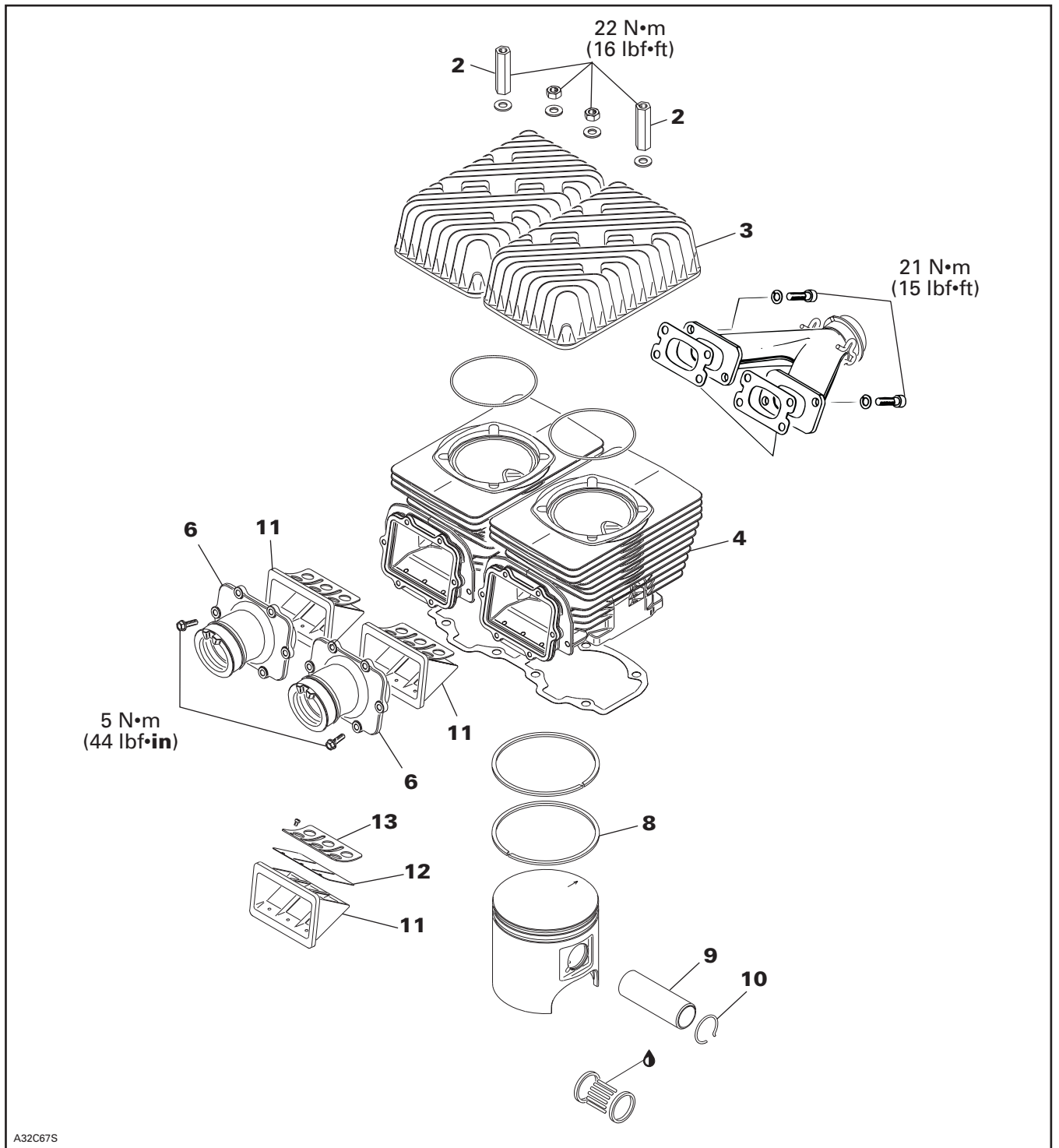

A32C67S

Section 03 ENGINES

Subsection 05 (TOP END)

TROUBLESHOOTING

Before completely disassemble engine, proceed with an engine leak test. Refer to LEAK TEST.

Component Removal with the Engine Installed

Most engine components can be removed with engine on vehicle such as:

- engine fan cowls
- cylinder head
- cylinder(s)
- piston(s)
- reed valve(s).

CLEANING

Discard all gaskets. Use Loctite Chisel (P/N 413 708 500) to clean mating surfaces.

Clean all metal components in a non-ferrous metal cleaner.

Scrape off carbon formation from cylinder exhaust port, cylinder head and piston dome.

NOTE: The letters "AUS" and arrow on the piston dome must be visible after cleaning.

Clean the piston ring grooves with a groove cleaner tool, or with a piece of broken ring.

DISASSEMBLY

Remove top fan cowl, intake sockets and lower fan cowl.

Remove cylinder heads.

Remove cylinders.

NOTE: If engine is being taken apart in vehicle, cylinder studs must be removed first.

Place a clean cloth or rubber pad (P/N 529 023 400) over crankcase to prevent circlips **no. 10** from falling into crankcase. Then with a pointed tool inserted in piston notch, remove both circlips from piston **no. 8**.

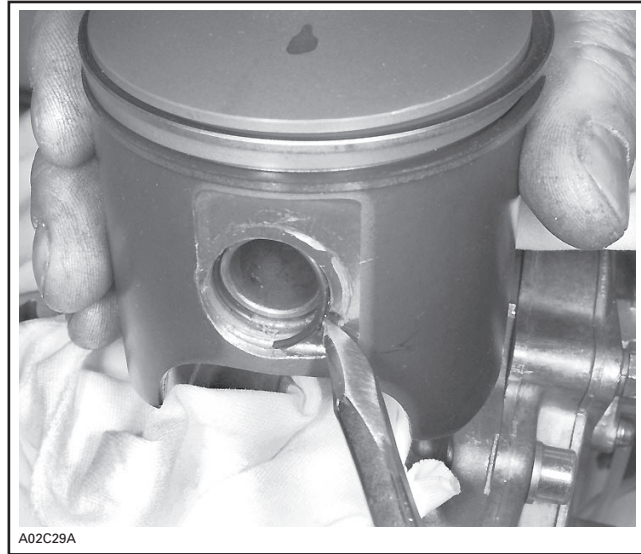

TYPICAL

To remove piston **no. 8**, use the following tools:

NOTE: The PTO cylinder or fan housing have to be removed to give access to MAG piston with puller.

377 Engine

ENGINE	PULLER P/N
377	529 035 503

Extract piston pin **no. 9**, with puller.

Fully screw puller handle.

Insert puller end into piston pin.

Screw (LH threads) extracting nut.

Hold puller firmly and rotate puller handle counter-clockwise to pull piston pin.

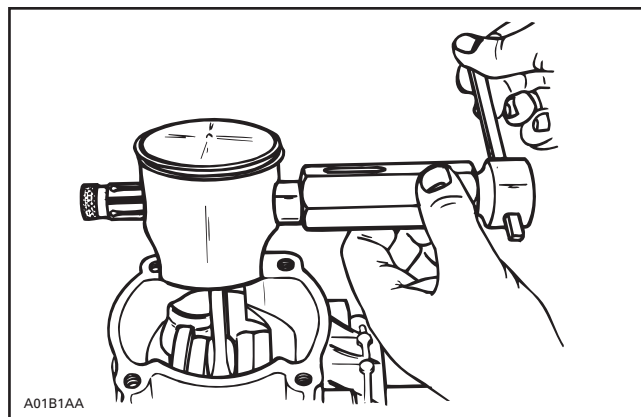

TYPICAL

Section 03 ENGINES
Subsection 05 (TOP END)

552 Engine

ENGINE	PULLER P/N	SLEEVE KIT P/N	LOCATING SLEEVE P/N
552	529 035 503	529 035 542 (20 mm)	529 023 800

NOTE: On this engine, piston pin needle bearing is mounted without a cage. The locating sleeve is the same that contains new cageless bearing.

Insert piston pin puller making sure it sits squarely against piston.

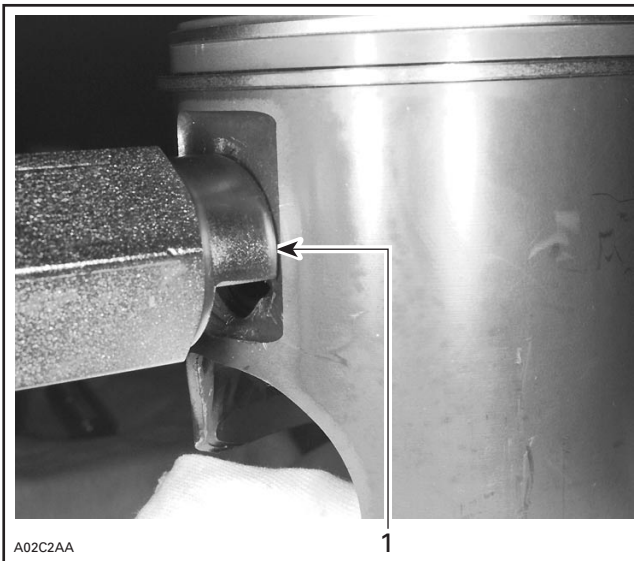

TYPICAL
 1. Properly seated all around

Install sleeve then shouldered sleeve over puller rod.

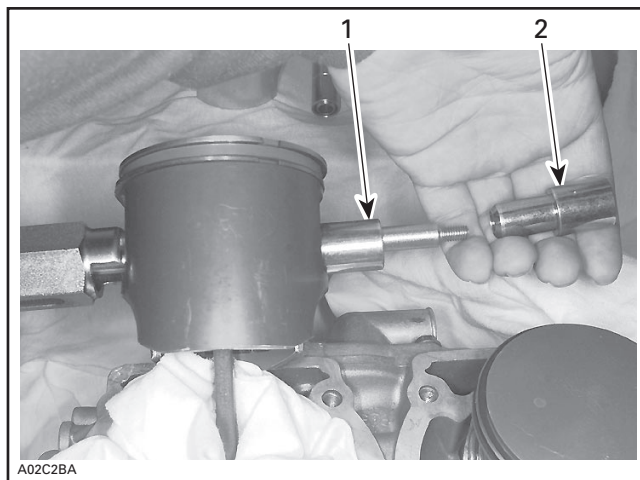

TYPICAL — INSTALLATION OF SLEEVE KIT
 1. Sleeve
 2. Shouldered sleeve

Extract piston pin no. 10 by unscrewing puller until shouldered sleeve end is flush with thrust washer of piston pin bearing.



TYPICAL — PISTON PIN EXTRACTION

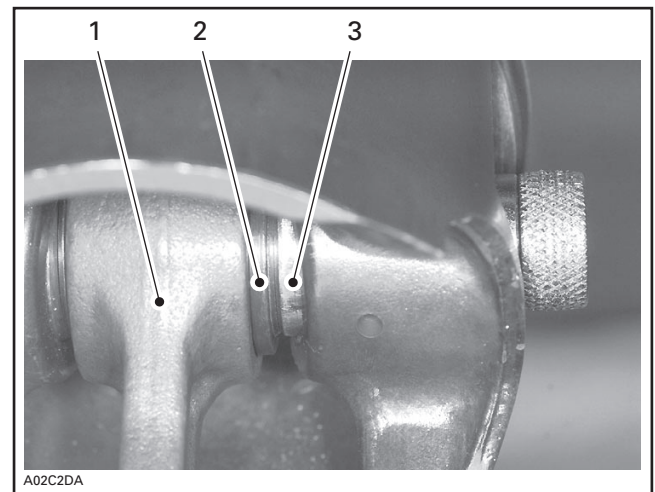

TYPICAL
 1. Sleeve inside bearing
 2. Thrust washer
 3. Shouldered sleeve end

Remove puller. Pull out shouldered sleeve carefully.

Section 03 ENGINES

Subsection 05 (TOP END)

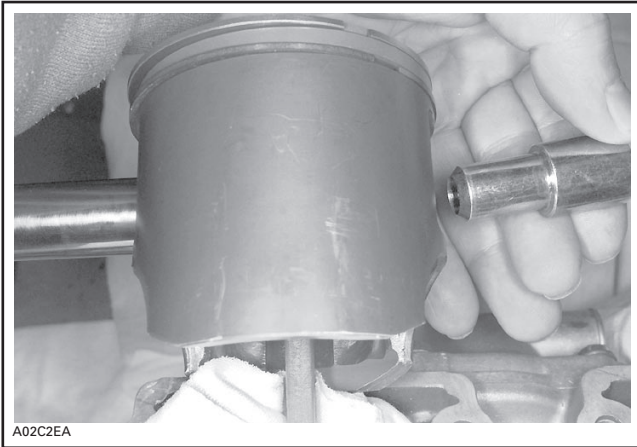

TYPICAL

Remove piston from connecting rod.
Install locating sleeve. Then push needle bearings along with thrust washers and sleeve.

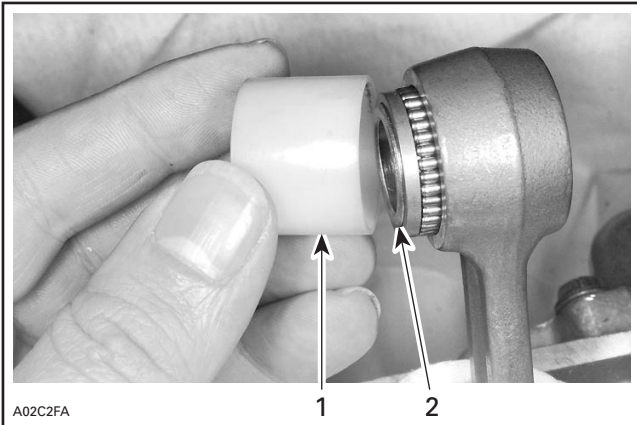

TYPICAL

1. Locating sleeve
2. Sleeve

NOTE: 0.25 and 0.5 mm oversized pistons are available if necessary.

Use a locking tie to fasten all needles and thrust washers along with locating sleeve.

INSPECTION

NOTE: Refer to table below to find top end engine dimension specifications. For dimension measurement procedures, refer to ENGINE MEASUREMENT.

ENGINE MEASUREMENT	TOLERANCES		
	NEW PARTS (min.)	(max.)	WEAR LIMIT
Cylinder head volume 377 engine	19.55 cc	21.15 cc	N.A.
Cylinder head volume 552 engine	34.34 cc	36.74 cc	N.A.
Cylinder head warpage	N.A.	N.A.	0.5 mm (.02 in)
Cylinder taper	N.A.	0.05 mm (.002 in)	0.1 mm (.004 in)
Cylinder out of round	N.A.	0.010 mm (.0004 in)	0.08 mm (.003 in)
Piston/cylinder wall clearance 377 engine	0.054 mm (.002 in)	0.086 mm (.003 in)	0.20 mm (.008 in)
Piston/cylinder wall clearance 552 engine	0.12 mm (.005 in)	0.17 mm (.007 in)	0.20 mm (.008 in)
Ring/piston groove clearance 377 engine	0.040 mm (.0016 in)	0.110 mm (.0043 in)	0.20 mm (.008 in)
Ring/piston groove clearance 552 engine	0.037 mm (.0015 in)	0.077 mm (.003 in)	0.20 mm (.008 in)
Ring end gap 377 engine	0.20 mm (.008 in)	0.35 mm (.014 in)	1.0 mm (.039 in)
Ring end gap 552 engine	0.40 mm (.016 in)	0.55 mm (.022 in)	1.0 mm (.039 in)

ASSEMBLY

To ease piston installation, heat piston using bearing heater (P/N 529 035 969).



CAUTION: Piston temperature must not exceed 46°C (115°F). NEVER USE DIRECT FLAME to heat the piston and never freeze the pin. Inappropriate heating procedure(s) may damage the piston.

377 Engine

To center the piston pin with the connecting rod bearing, use centering tool (P/N 529 009 100).

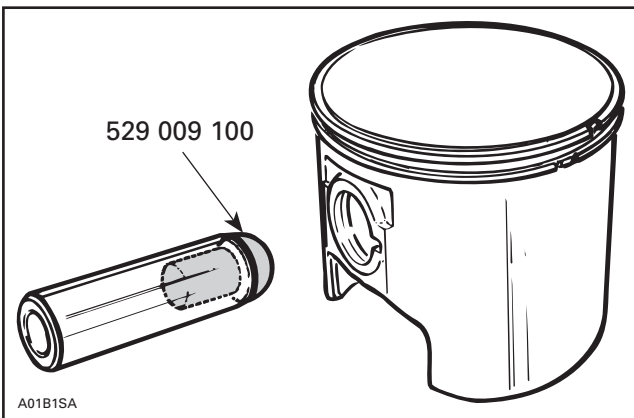

NOTE: The circlip on the opposite side can be installed before pin installation, the tool will easily go out.

Use piston pin puller (P/N 529 035 503) to install a piston pin that cannot be installed as described above.

To minimize the effect of acceleration forces on circlip, install each circlip so the circlip break is at 6 o'clock as illustrated. Use piston circlip installer (P/N 529 035 561).

Insert circlip in tool at an angle.

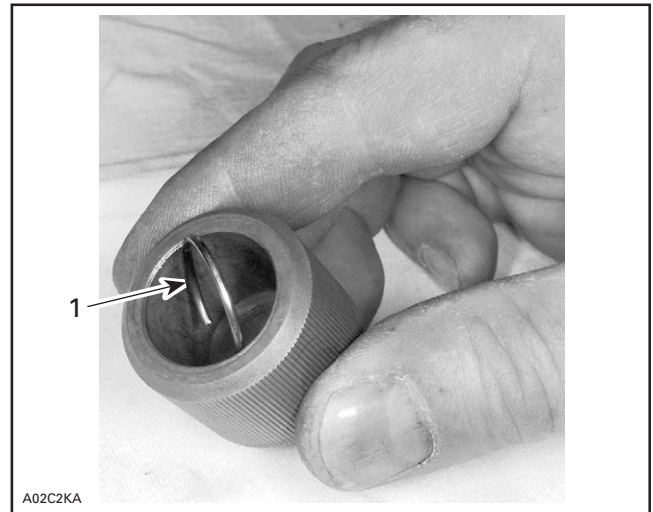

1. Circlip

Square it up using a finger.

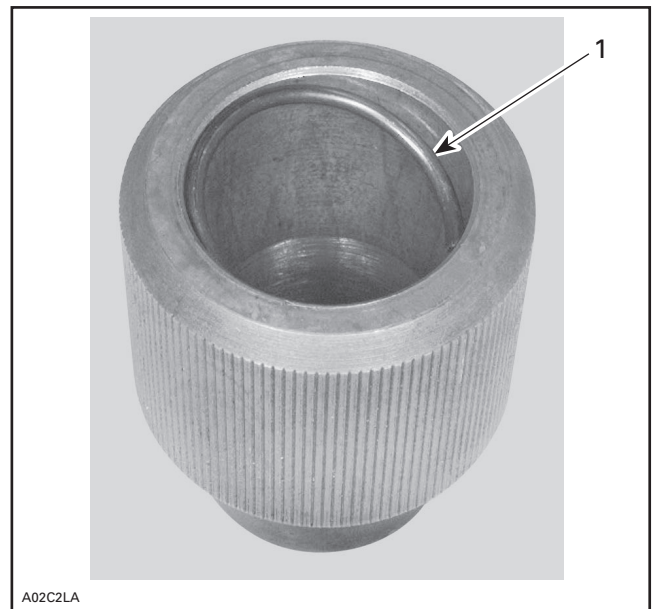

1. Circlip

Continue to square it up using round end of circlip installer.

Section 03 ENGINES
Subsection 05 (TOP END)

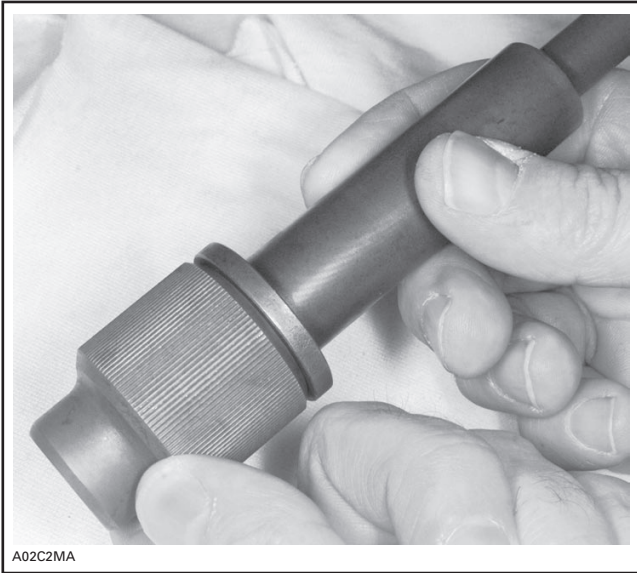

Using square end of tool, push circlip in until it rests in groove.

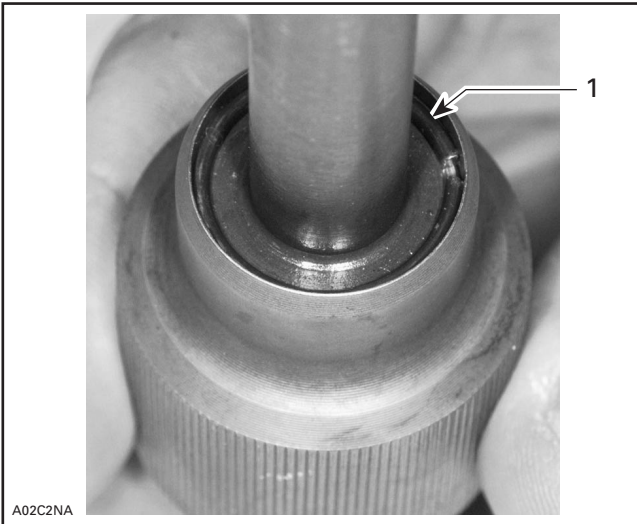

1. Circlip in groove

Mount tool in piston making sure that circlip break is facing down.

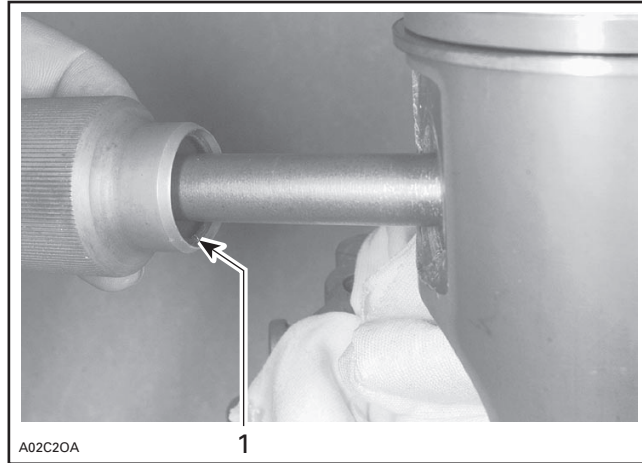

TYPICAL
 1. Circlip break facing down

Hold tool firmly against piston then strike on round end of tool with a plastic hammer. Circlip will move from tool groove to piston groove.

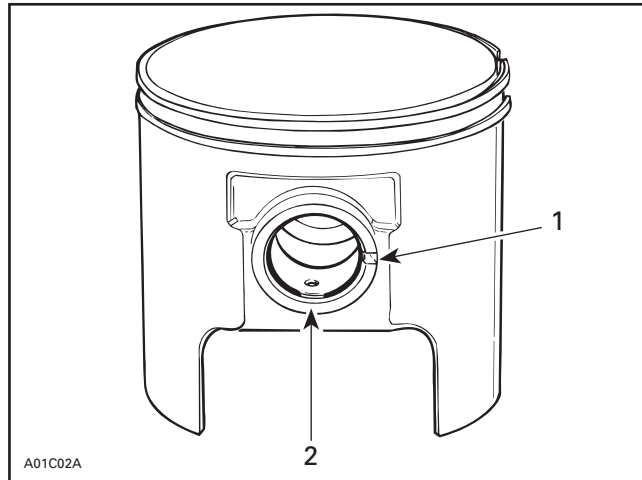

1. Piston notch
 2. Circlip break at 6 o'clock

CAUTION: Circlips must not move freely in the groove after installation. If so, replace them.

552 Engine

When reinstalling original needle bearings, make sure that 34 needles are inserted between sleeve and locating sleeve.

When installing a new cageless bearing, replace half plastic cages by sleeve.

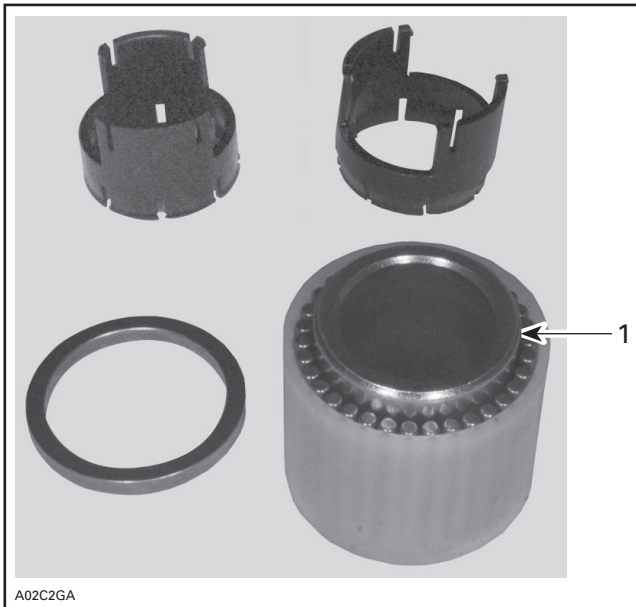

TYPICAL
 1. Sleeve

Grease thrust washers and install them on each end of needles.

Insert cageless bearing into connecting rod.



TYPICAL — CAGELESS BEARING AND SLEEVE INSTALLED

Mount piston over connecting rod with the letters "AUS" (over an arrow on the piston dome) facing in the direction of exhaust port.

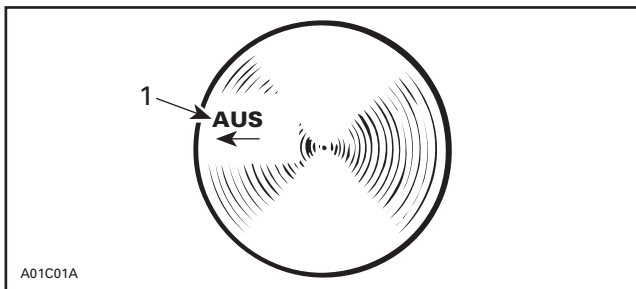

1. Exhaust

Install shouldered sleeve.



TYPICAL — SHOULDERED SLEEVE INSTALLATION

Install piston pin puller and turn handle until piston pin is correctly positioned in piston.



TYPICAL

- Remove piston pin puller and sleeve kit.
- Use piston circlip installer (P/N 529 035 686) to install new mono-hook circlips **no. 10**.
- Insert circlip into support in such a way that when installed in piston groove, the tab will face upward.

Section 03 ENGINES
Subsection 05 (TOP END)



With round end of pusher, position circlip perpendicular to the support axis.

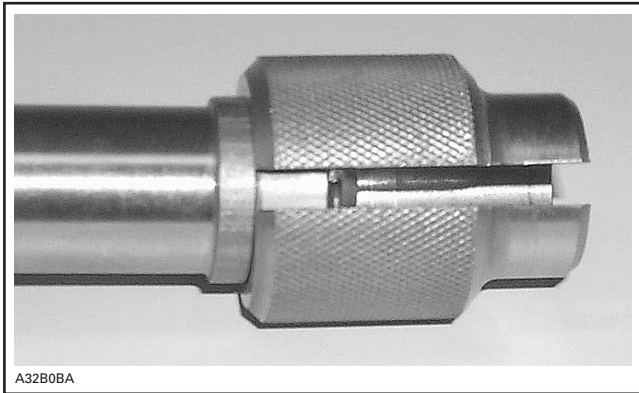

With the other end of the pusher, push circlip into the support groove.

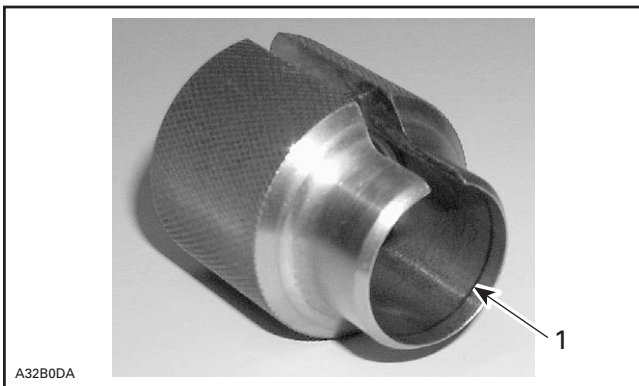
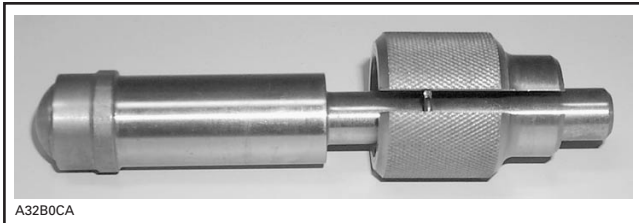

1. Groove

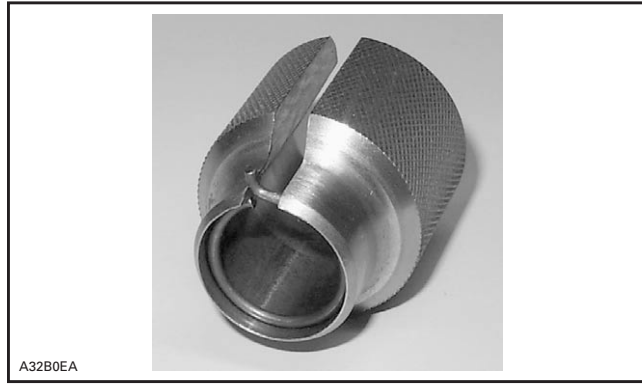

CIRCLIP READY TO BE INSTALLED ON PISTON

Using a plastic hammer, tap pusher to insert circlip in place. Take care to install new circlips with tab toward top as per following photo.

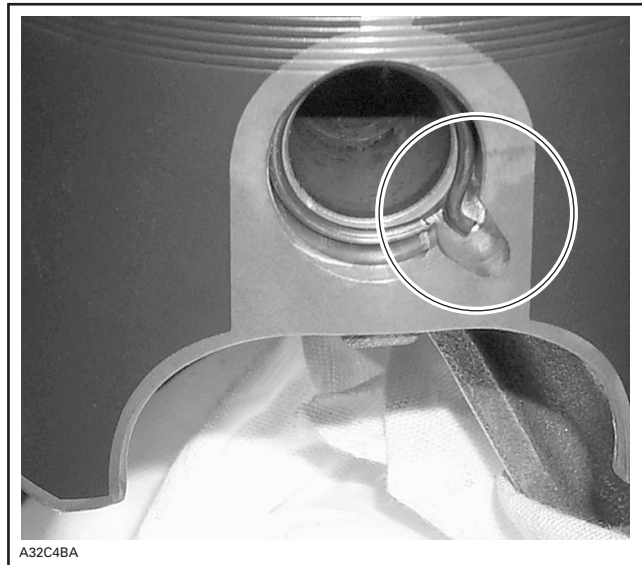

TAB TOWARD TOP

CAUTION: Always install new mono-hook circlips. If circlip installation fails at the first attempt, always retry with a new one as on a second attempt circlip will lose its normal retaining capabilities.

CAUTION: Circlips must not move freely after installation; if so, replace them.

377 and 552 Engines

Apply a thin layer of Loctite 518 (P/N 293 800 038) to crankcase mating surface of base gasket. Choose the right gasket thickness according to combustion chamber volume. Install it on crankcase. Apply a thin layer of Loctite 518 to gasket surface area.

Section 03 ENGINES
Subsection 05 (TOP END)

CAUTION: Always install a gasket of the proper thickness. Failure to do so may cause detonation and severe engine damage.

NOTE: Be sure to restore the chamfer around all cylinder sleeve port openings.

Before inserting piston in cylinder **no. 4**, lubricate the cylinder with new injection oil or equivalent.

Install proper ring compressor on piston assembly.

ENGINE	RING COMPRESSOR P/N
377	420 876 090
552	420 876 972

NOTE: The ring compressor will not fit on over size pistons.

Check flatness of intake sockets **no. 6**.

At cylinder **no. 4** and/or cylinder head **no. 3** installation, use aligning tool or exhaust manifold itself to ensure sealing of intake manifold and exhaust before tightening cylinder head nuts.

ENGINE	ALIGNING TOOL P/N
377 and 552	420 876 171

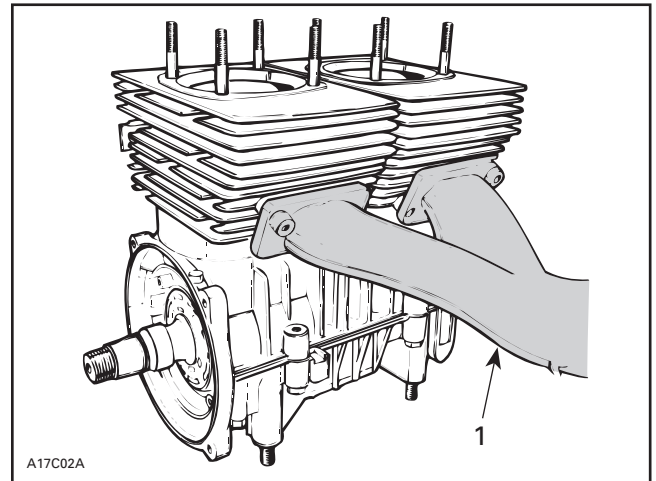
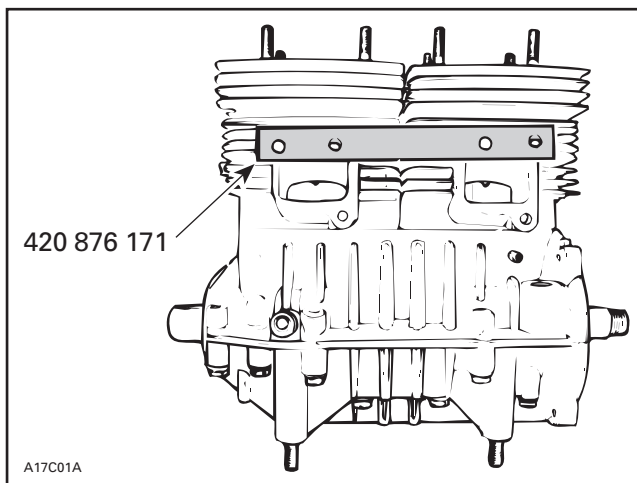

1. Or use exhaust manifold to align cylinders

Position distance nuts **no. 2** as shown below.

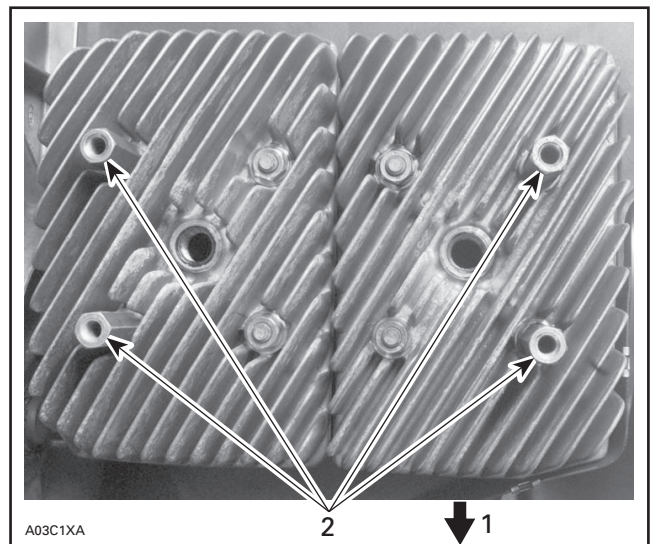

1. Exhaust
2. Distance nuts

Cross torque cylinder head nuts **no. 1** and **no. 2** to 22 N•m (16 lbf•ft); torque each cylinder head individually.

Torque intake socket bolts to 22 N•m (16 lbf•ft).
Install engine fan cowls.

552 Engine

12, Reed Valve

Blades **no. 12** have a curved shape. Install with their curve facing reed block.

Section 03 ENGINES

Subsection 05 (TOP END)

With blade stopper no. 13 removed, check reed valve for proper tightness. There must be no play between blade and valve body when exerting a finger pressure on blade at blade stopper location.

In case of a play, turn blade upside down and recheck. If there is still a play, replace blade and/or valve body.

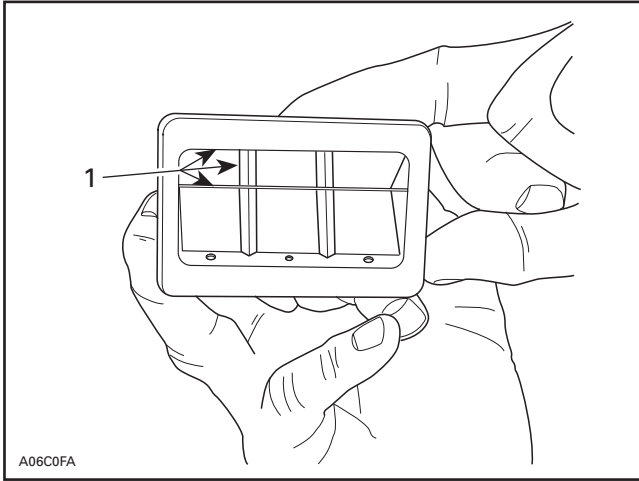

1. No play

Check distance from blade stopper inner edge and distance from center of reed valve block.

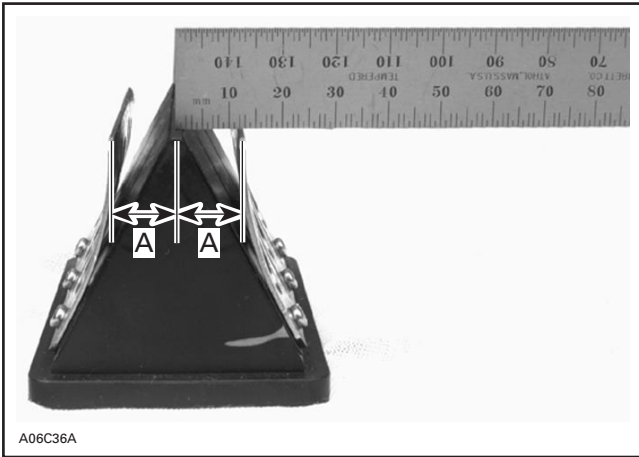

TYPICAL

A. 14.75 - 0, + 0.75 mm (.580 - 0, + .030 in)

Bent blade stopper as required to obtain the proper distance.

Blade stoppers may slightly interfere with cylinder during installation. Adjusted distance will be reduced automatically upon installation.

593 Engine

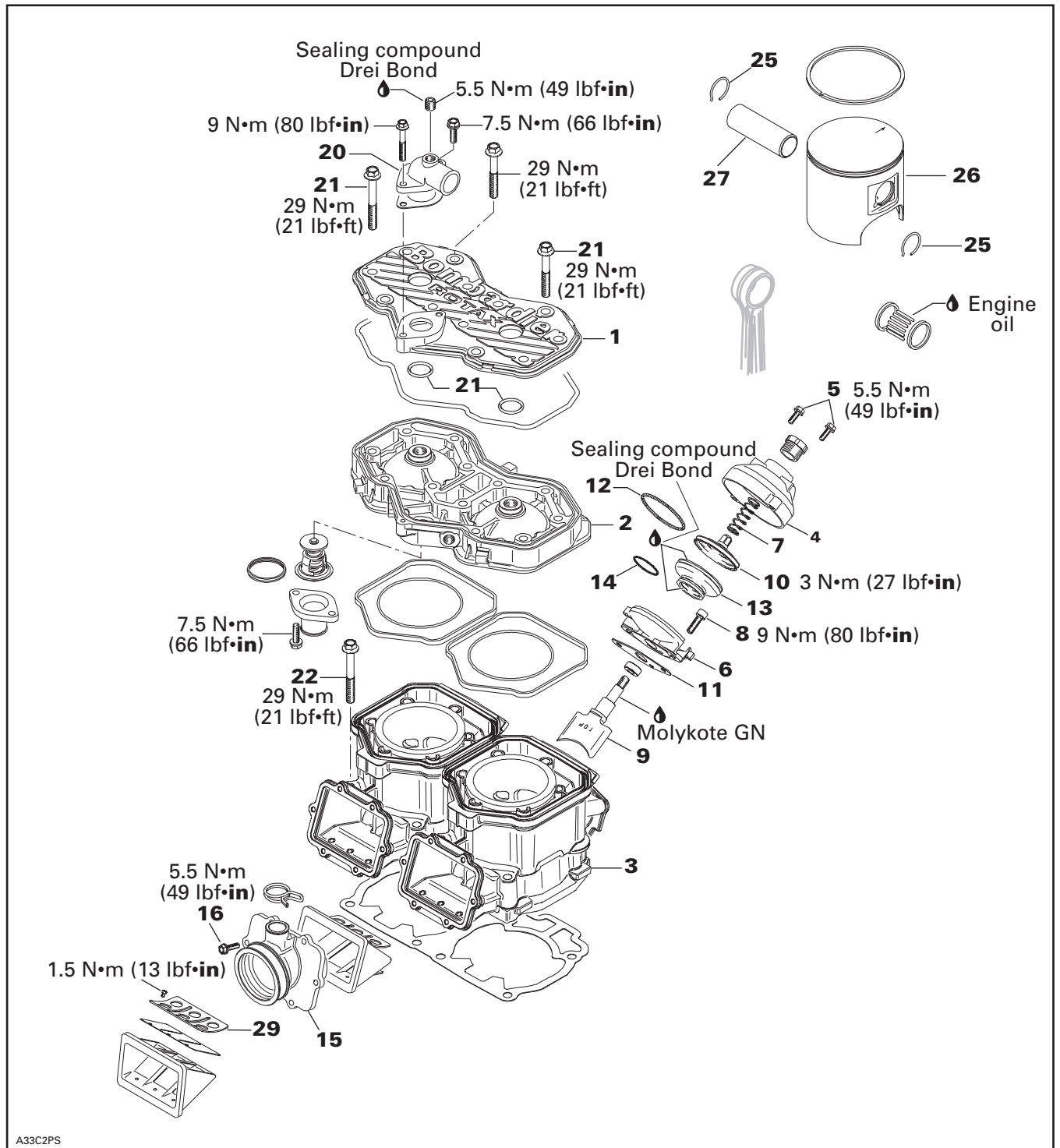

A33C2PS

Section 03 ENGINES
Subsection 05 (TOP END)

593 HO Engine

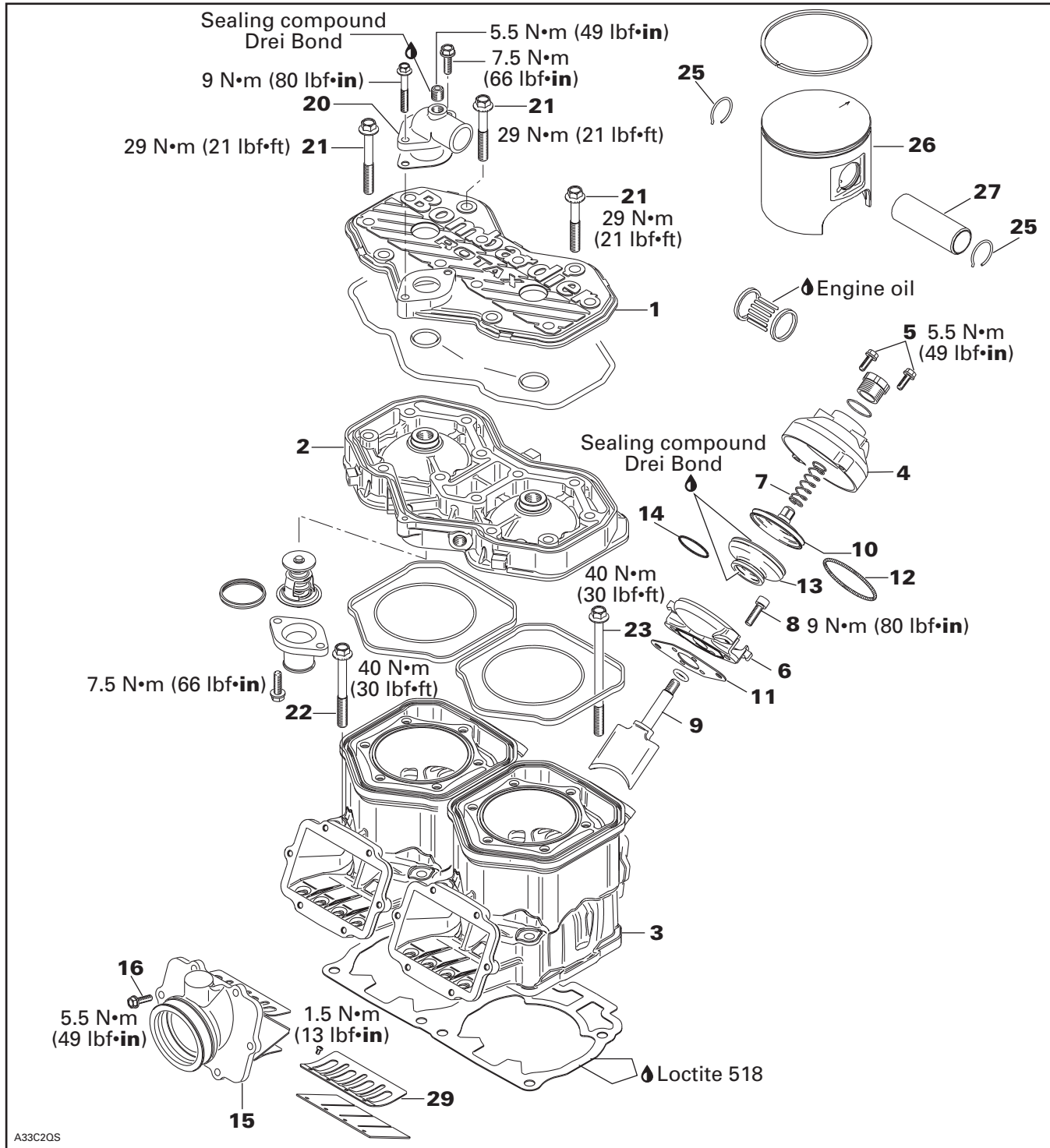

A33C2QS

Section 03 ENGINES
Subsection 05 (TOP END)

593 HO SDI Engine

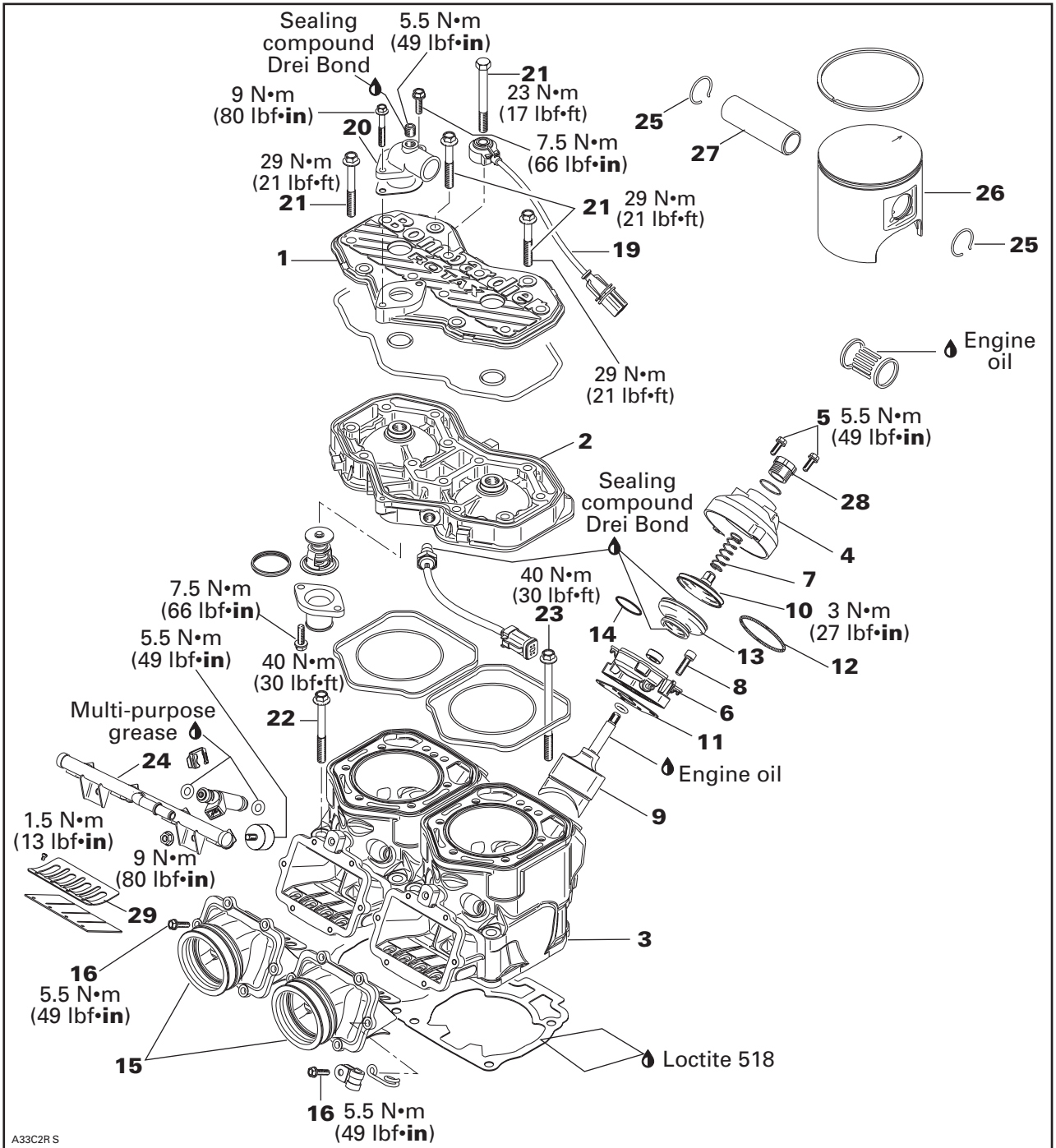

Section 03 ENGINES
Subsection 05 (TOP END)

793 HO Engine

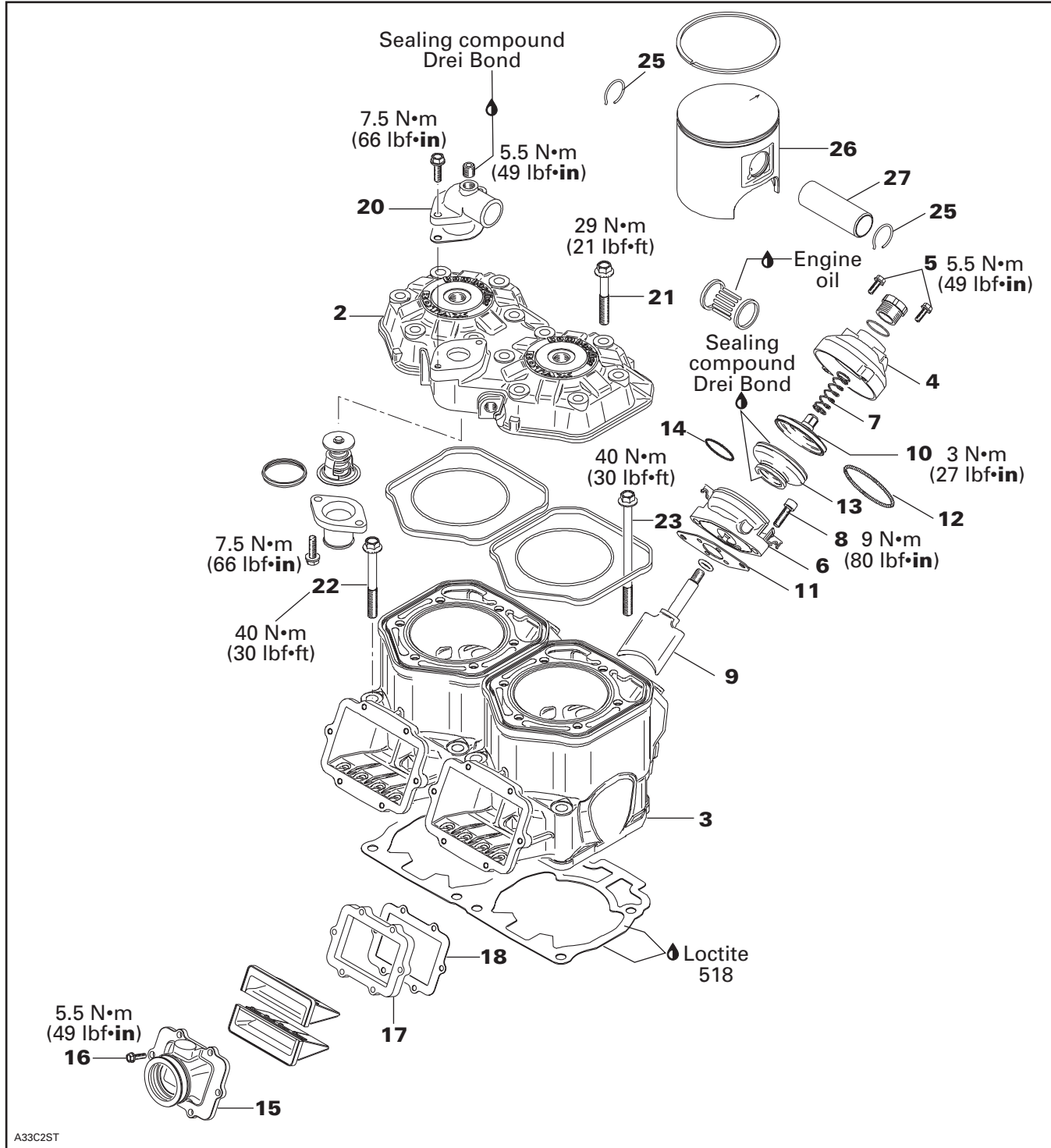

A33C2ST

Section 03 ENGINES
Subsection 05 (TOP END)

793 HO Engine (Power Tek)

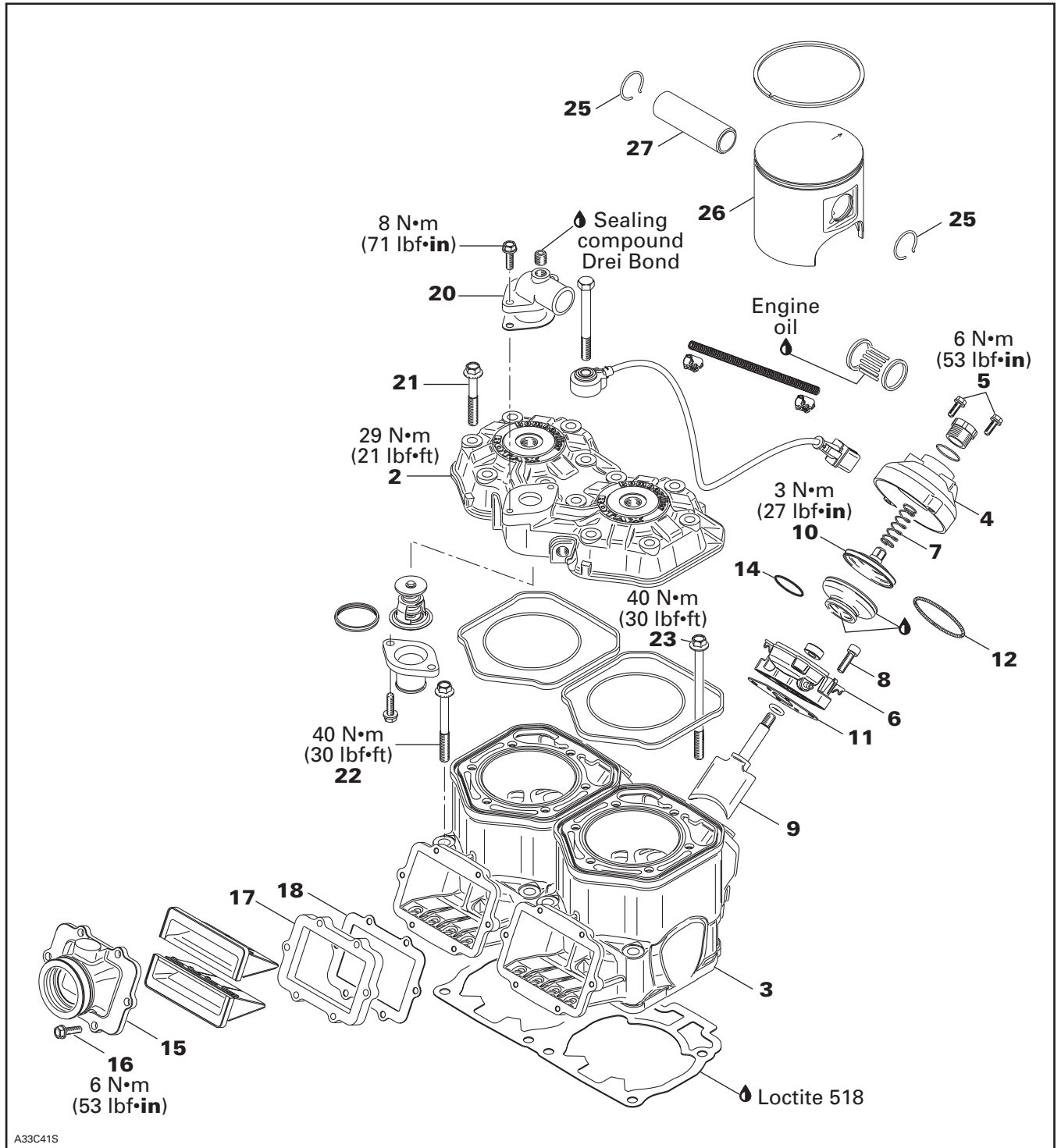

A33C41S

Section 03 ENGINES

Subsection 05 (TOP END)

TROUBLESHOOTING

Before completely disassembling the engine, proceed with an engine leak test. Refer to LEAK TEST.

COMPONENT REMOVAL WITH THE ENGINE INSTALLED

Most engine components can be removed with engine on vehicle such as:

- cylinder head
- cylinder(s)
- piston(s)
- RAVE valve(s)
- reed valve(s).

CLEANING

Discard all gaskets and O-rings. Use Loctite Chisel (P/N 413 708 500) to clean mating surfaces.

Clean all metal components in a non-ferrous metal cleaner.

Scrape off carbon formation from cylinder exhaust port cylinder head and piston dome.

NOTE: The letters "AUS" (over an arrow on the piston dome) must be visible after cleaning.

Clean the piston ring groove with a groove cleaner tool or with a piece of broken ring.

RAVE VALVE BASIC OPERATION

NOTE: RAVE stands for Rotax Adjustable Variable Exhaust.

The RAVE valves change the height of the exhaust port to enhance the engine powerband and torque according to the engine RPM and throttle position (e-RAVE on Power Tek and SDI engines).

All Engines except Power Tek and SDI

Exhaust pressure is used to inflate the bellows and open the RAVE valves at the proper engine RPM.

Power Tek and SDI Engines with E-RAVE

According to engine RPM and throttle position, the ECM activates a solenoid which allows crankcase positive pressure to inflate the bellows and open the RAVE valves.

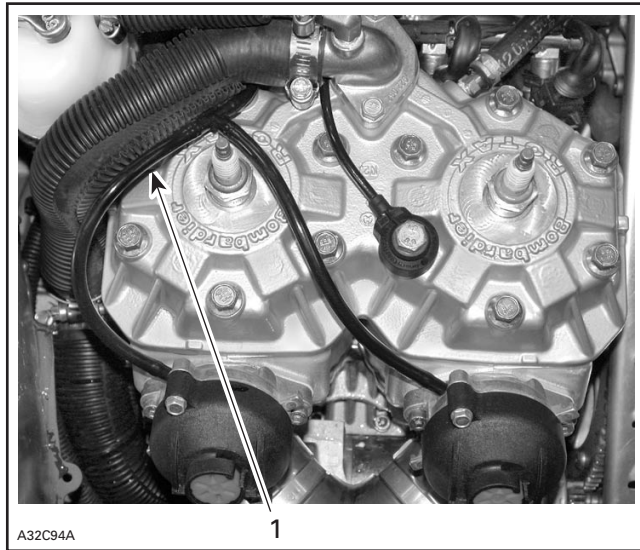

TYPICAL — SDI ENGINE SHOWN
1. Pressure from solenoid

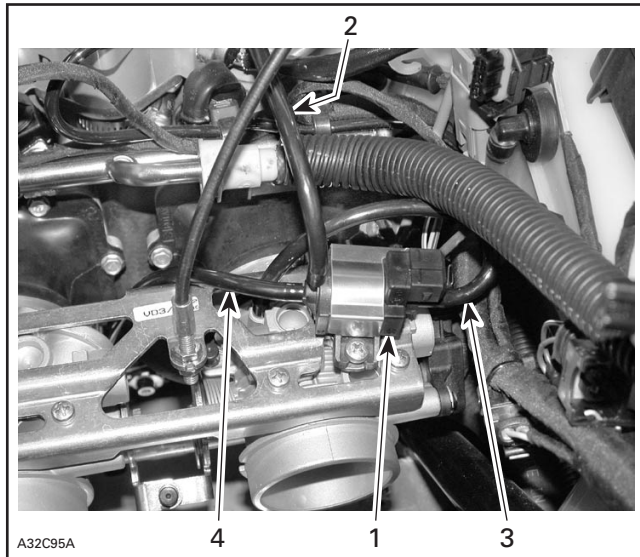

TYPICAL — SDI ENGINE SHOWN
1. Solenoid
2. Pressure to RAVE valves
3. Vent to throttle body
4. Pressure with check valve from crankcase

To close the RAVE valves, the ECM deactivates the solenoid. The RAVE valves are opened to the intake.

DISASSEMBLY

RAVE Valves

Remove RAVE valve cover no. 4 by removing screws no. 5.

⚠ WARNING

Firmly hold cover to valve base no. 6. The compression spring no. 7 inside the valve is applying pressure against the cover.

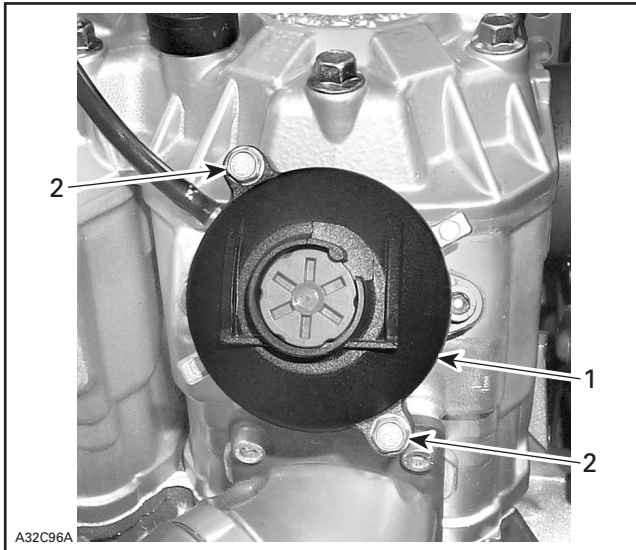

TYPICAL
1. Cover
2. Retaining screws

Remove the compression spring no. 7.



TYPICAL

Unscrew the Allen socket screw no. 8 then remove the RAVE valve base no. 6.

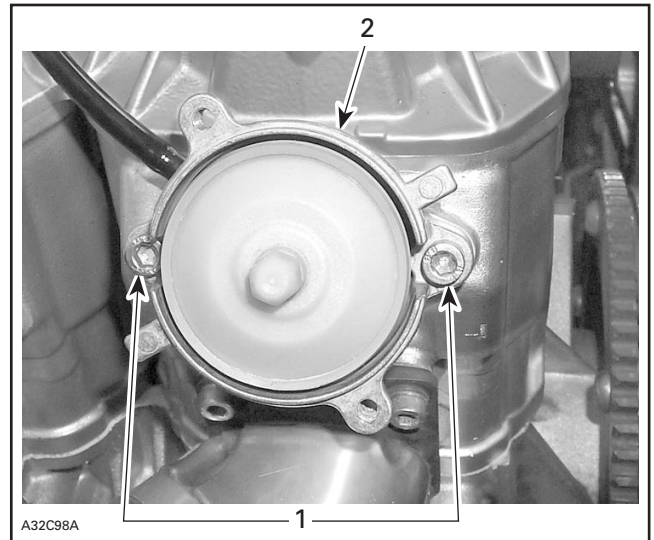

TYPICAL
1. Allen socket screws
2. RAVE valve base

Unscrew and remove the guillotine no. 9 from the valve piston no. 10 then remove the gasket no. 11.

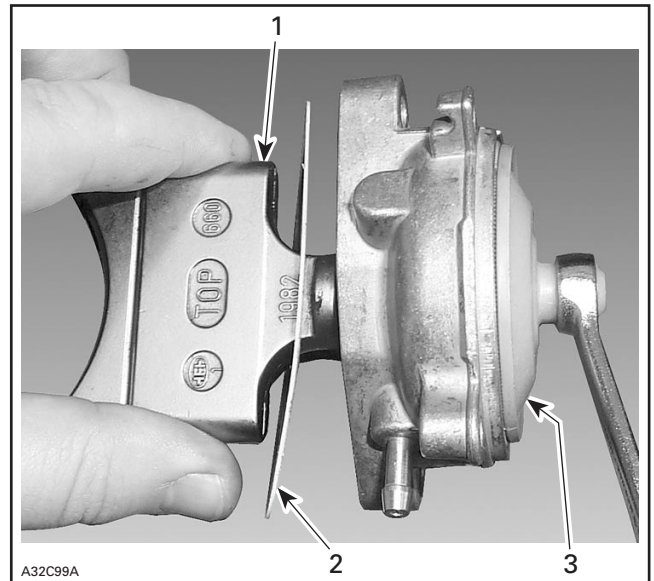

TYPICAL
1. Guillotine
2. Gasket
3. Valve piston

Remove spring no. 12 retaining bellows no. 13 to valve piston.

Section 03 ENGINES
Subsection 05 (TOP END)

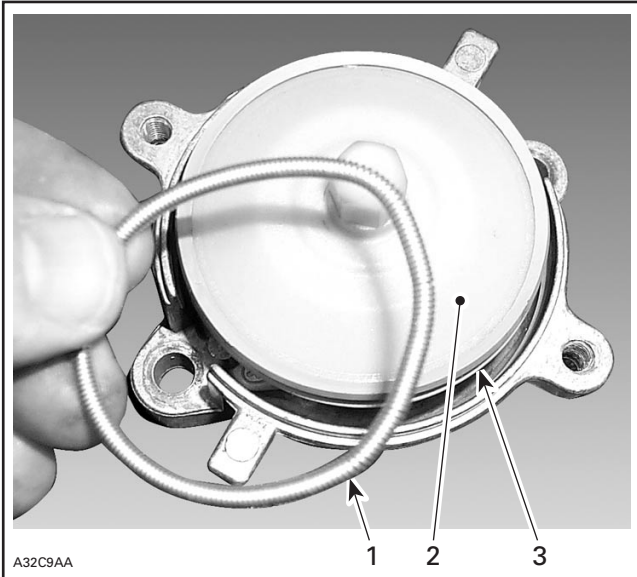

TYPICAL
1. Spring
2. Valve piston
3. Bellows

Remove valve piston.

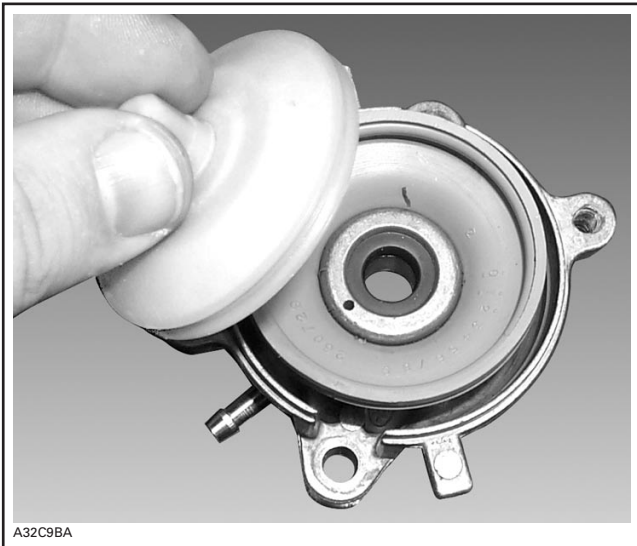

TYPICAL

Remove the small spring no. 14 retaining bellows to valve base.

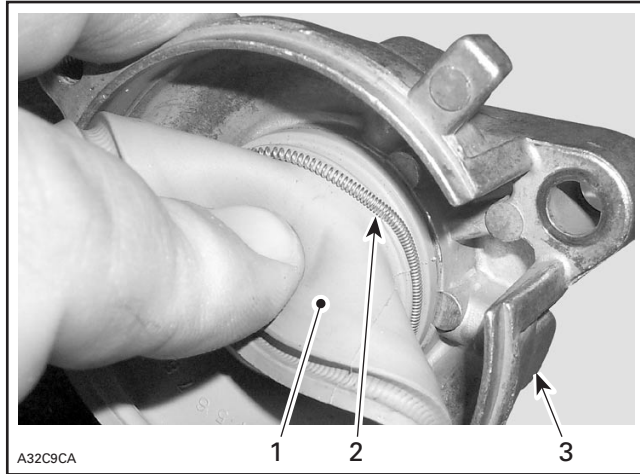

TYPICAL
1. Bellows
2. Small spring
3. Valve base

Remove bellows from valve base.

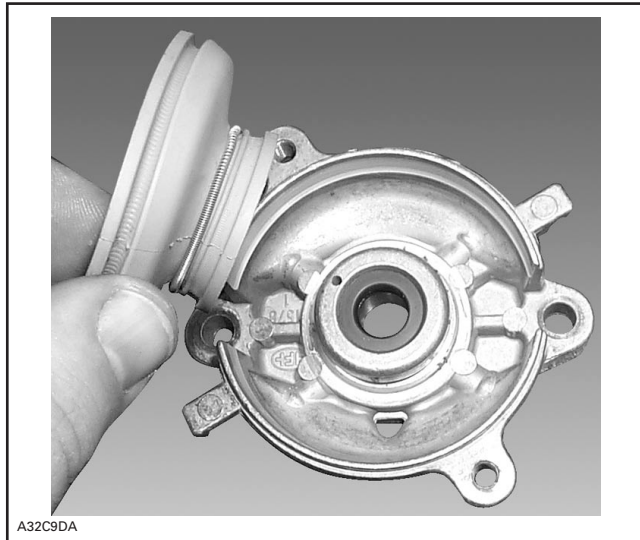

TYPICAL

REED Valve

593 Engine

Remove intake resonator on top of reed valves no. 15.

All Engines

Unscrew reed valve screws no. 16 then remove reed valve(s).

793 HO Engine

Remove connecting flange no. 17 and gasket no. 18.

Cylinder Head Cover
All Engines Except 793 HO

Unplug spark plug cables.
Disconnect the knock sensor **no. 19** (593 HO SDI engine).
Unplug coolant hose from upper thermostat housing **no. 20**.
Unscrew all cylinder head cover screws **no. 21**.

Cylinder Head
All Engines except 793 HO

Remove the cylinder head cover **no. 1** as explained above.
Disconnect the temperature sensor connector.
Remove the cylinder head **no. 2**.

793 HO Engines

Unplug spark plug cables.
Disconnect the knock sensor **no. 19** (793 HO Power Tek engine).
Disconnect the temperature sensor connector.
Unplug coolant hose from upper thermostat housing **no. 20**.
Unscrew all cylinder head screws **no. 21**.
Remove the cylinder head **no. 2**.

Cylinder
593 HO SDI Engine

Release the fuel pressure of the system.
Unplug fuel injector connectors then remove the fuel rail **no. 24**. Refer to COMPONENT INSPECTION, REPLACEMENT AND ADJUSTMENT.

All Engines

Remove cylinder head **no. 2** as explained above.
Remove manifold and RAVE valves.
Unscrew cylinder screws **no. 22** and **no. 23** then remove the cylinder(s) **no. 3**.

Piston

Place a clean cloth or rubber pad (P/N 529 023 400) over crankcase. Then with a pointed tool inserted in piston notch, remove both circlips **no. 25** from piston **no. 26**.

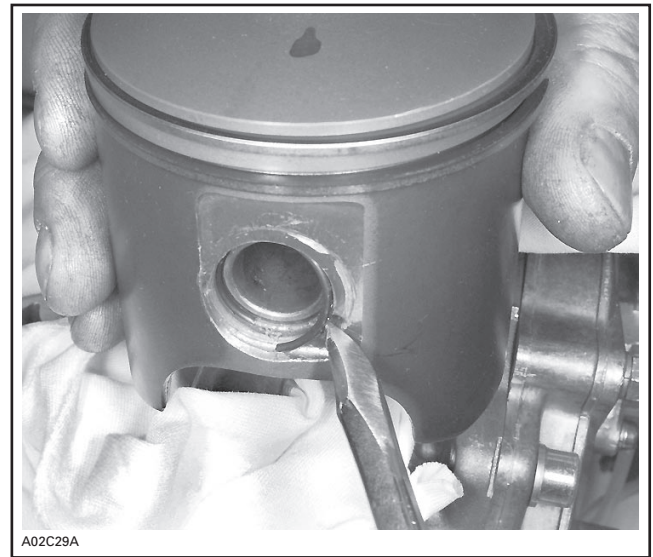

TYPICAL

NOTE: All engines are equipped with cageless piston pin bearings.

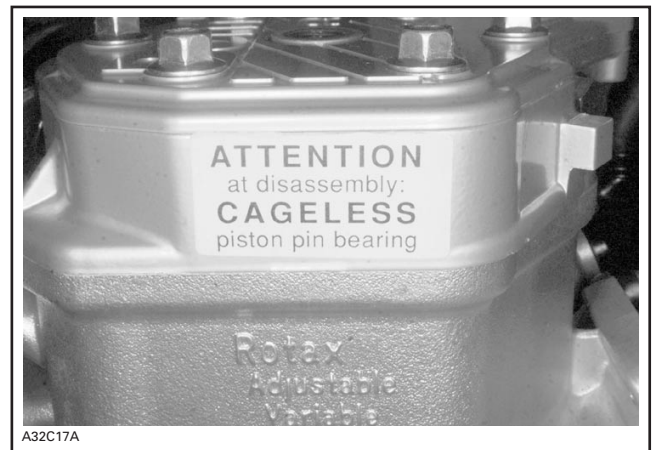

To remove piston **no. 26**, use the following tools:

ENGINE	PULLER P/N	SLEEVE KIT P/N	LOCATING SLEEVE P/N
All	529 035 503	529 035 542 (20 mm)	529 023 800

NOTE: The locating sleeve is the same that contains new cageless bearing.

Insert piston pin puller making sure it sits squarely against piston.

Section 03 ENGINES
Subsection 05 (TOP END)



TYPICAL
 1. Properly seated all around

Install sleeve then shouldered sleeve over puller rod.

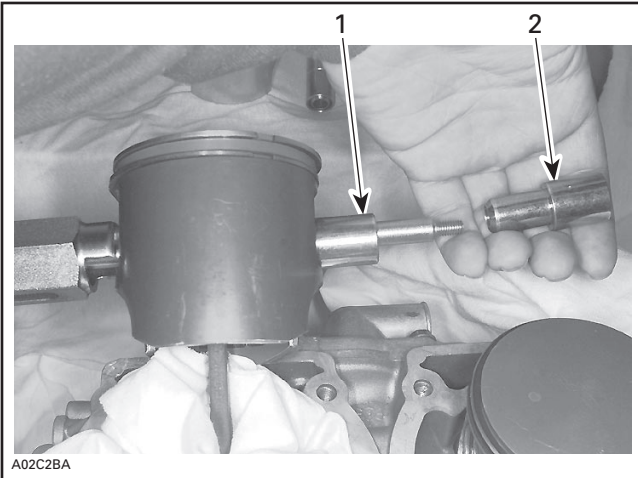

TYPICAL — INSTALLATION OF SLEEVE KIT
 1. Sleeve
 2. Shouldered sleeve

Screw (LH threads) extracting nut.

Pull out piston pin **no. 27** by unscrewing puller until shouldered sleeve end is flush with thrust washer of piston pin bearing.

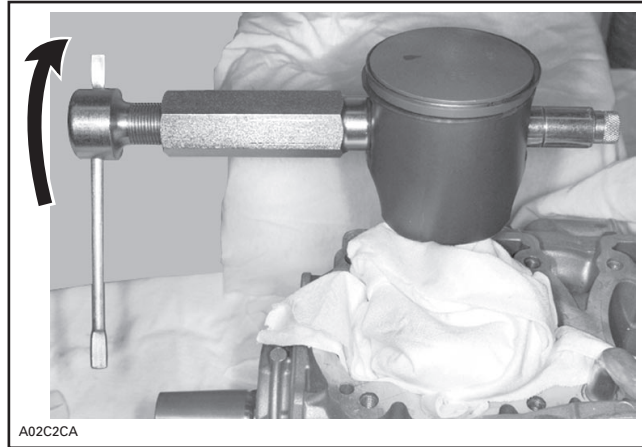

TYPICAL — PISTON PIN EXTRACTION

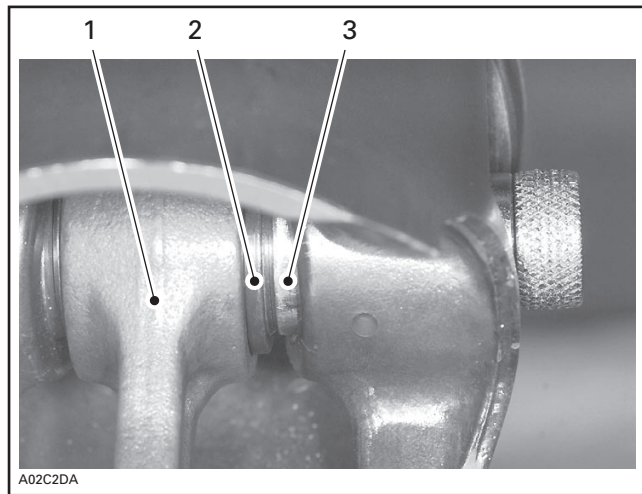

TYPICAL
 1. Sleeve inside bearing
 2. Thrust washer
 3. Shouldered sleeve end

Remove puller. Pull out shouldered sleeve carefully.

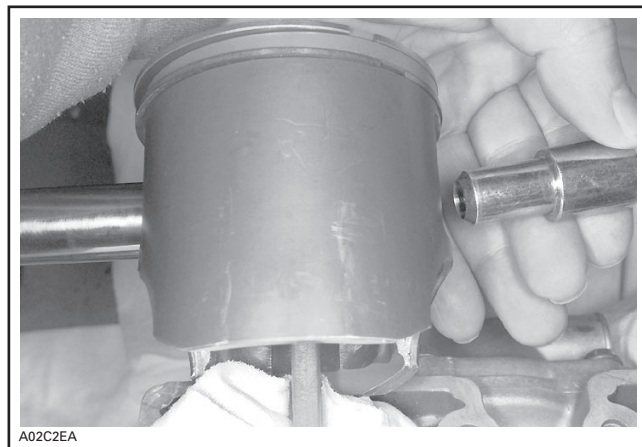

TYPICAL

Remove piston from connecting rod.
 Install locating sleeve. Then push needle bearings along with thrust washers and sleeve.

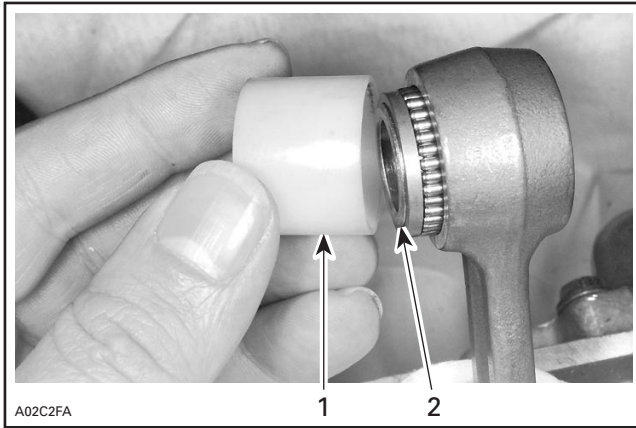

TYPICAL
 1. Locating sleeve
 2. Sleeve

INSPECTION

NOTE: For dimension measurement procedures, refer to ENGINE MEASUREMENT.

RAVE Valves

There are no wear parts anywhere in the system and there are no adjustments to be periodically checked. The only possible maintenance required would be cleaning of carbon deposits from the guillotine slide. Cleaning intervals would depend upon the user's riding style and the quality of the oil used.

BRP suggests annual cleaning of the valve. If a customer uses lower quality oil, than recommended, more frequent cleaning may be required.

No special solvents or cleaners are required when cleaning the valve.

Check valve rod housing and cylinder for clogged passages (all models except Power Tek and SDI).

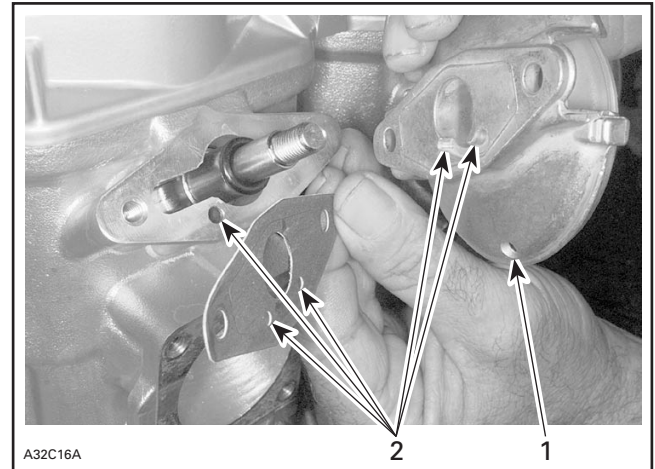

1. Draining hole
 2. Passages

NOTE: Oil dripping from draining hole indicates a loosen spring or damaged bellows.

Check for cracked, dried or perforated bellows no. 13.

Check if the compression springs no. 7 are in specifications.

ENGINE	SPRING P/N	COLOR	WIRE DIA. mm (in)	FREE LENGTH mm (in)
593	420 239 944	Brown	0.9 (.035)	48.5 (1.91)
593 HO	420 239 944	Brown	0.9 (.035)	48.5 (1.91)
593 HO SDI	420 239 942	Black	0.8 (.031)	42.5 (1.67)
793 HO (All models except Summit)	420 239 941	Blue	0.8 (.031)	52.5 (2.07)
793 HO (Summit)	420 239 942	Black	0.8 (.031)	42.5 (1.67)

Power Tek and SDI Engines

Check if solenoid heating element is still functional once a year, the element should be warm after one minute of riding. At the same time, check if crankcase check valve is still functional.

NOTE: Make sure hoses are not kinked or damaged.

Section 03 ENGINES
Subsection 05 (TOP END)

Cylinder Head, Cylinder and Piston

ENGINE MEASUREMENT	TOLERANCES		
	NEW PARTS (min.)	(max.)	WEAR LIMIT
Cylinder head volume 593 engine	25.49 cc	27.96 cc	N.A.
Cylinder head volume 593 HO/SDI engine	25.30 cc	27.60 cc	N.A.
Cylinder head volume 793 HO engine	34.76 cc	38.07 cc	N.A.
Cylinder head warpage All engines	N.A.	N.A.	0.50 mm (.02 in)
Cylinder taper All engines	N.A.	0.05 mm (.002 in)	0.10 mm (.004 in)
Cylinder out of round All engines	N.A.	0.010 mm (.0004 in)	0.08 mm (.003 in)
Piston/cylinder wall clearance 593 engine	0.104 mm (.004 in)	0.136 mm (.005 in)	0.20 mm (.008 in)
Piston/cylinder wall clearance 593 HO/SDI engines	0.092 mm (.0036 in)	0.118 mm (.0046 in)	0.18 mm (.007 in)
Piston/cylinder wall clearance 793 HO engine	0.103 mm (.002 in)	0.147 mm (.003 in)	0.20 mm (.008 in)
Ring/piston groove clearance 593 engine	0.040 mm (.002 in)	0.090 mm (.004 in)	0.20 mm (.008 in)
Ring/piston groove clearance 593 HO/SDI and 793 HO engines	0.050 mm (.002 in)	0.100 mm (.004 in)	0.20 mm (.008 in)
Ring end gap All engines	0.40 mm (.016 in)	0.55 mm (.022 in)	1.0 mm (.039 in)

Cylinder Boring Precaution

593 Engine

In its stock configuration, the RAVE valve guillotine has a minimum of 0.5 mm (.020 in) clearance to the cylinder bore measured at the center line of the cylinder. This is the minimum production clearance.

ASSEMBLY

RAVE Valves

Apply sealing compound Drei Bond (P/N 420 297 906) in the groove of valve base and in the piston valve groove, then install bellows.

Install RAVE valve with its mention top as illustrated in the following photo.



Tighten red cap screw **no. 28** to bottom.

Piston

When installing a new cageless bearing, replace half plastic cages with sleeve.

NOTE: Cageless bearing contains 28 needles on all engines.

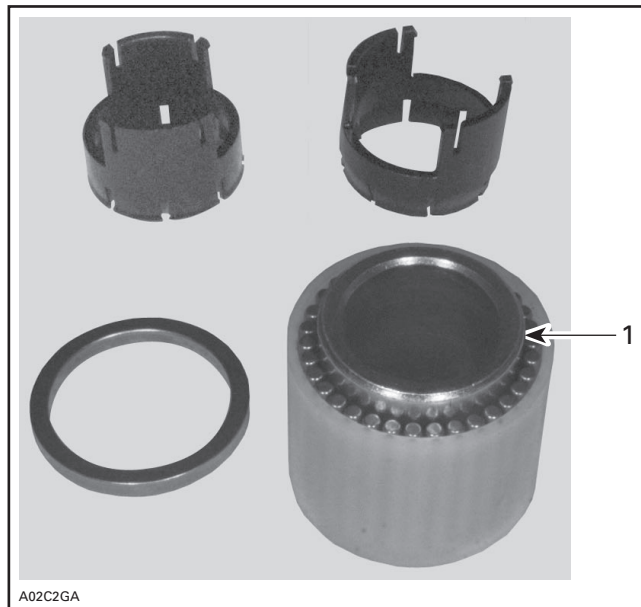

TYPICAL
 1. Sleeve

Section 03 ENGINES
Subsection 05 (TOP END)

Lubricate needle bearings and thrust washers with injection oil then install washers on each end of needles.

Insert cageless bearing into connecting rod.



TYPICAL — CAGELESS BEARING AND SLEEVE INSTALLED

Heat piston using bearing heater (P/N 529 035 969).



CAUTION: Piston temperature must not exceed 46°C (115°F). Never use direct flame to heat the piston and never freeze the pin.

At assembly, place the pistons over the connecting rods with the letters "AUS" (over an arrow on the piston dome) facing towards the exhaust port.

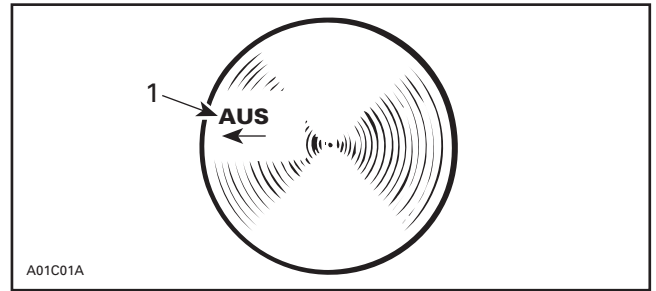

1. Exhaust

Install shouldered sleeve.



TYPICAL — SHOULDERED SLEEVE INSTALLATION

Install piston pin puller and turn handle until piston pin is correctly positioned in piston.



TYPICAL

CAUTION: Always install new circlips.

Section 03 ENGINES
Subsection 05 (TOP END)

To minimize the effect of acceleration forces on circlip, install each circlip so the circlip break is at 6 o'clock as illustrated. Use appropriate piston circlip installer to install mono-hook circlips no. 25.

ENGINE	TOOL
All	piston circlip installer (P/N 529 035 686)

Insert circlip into support so that, when installed in piston groove, the tab faces upward.



With round end of pusher, position circlip perpendicularly to the support axis.

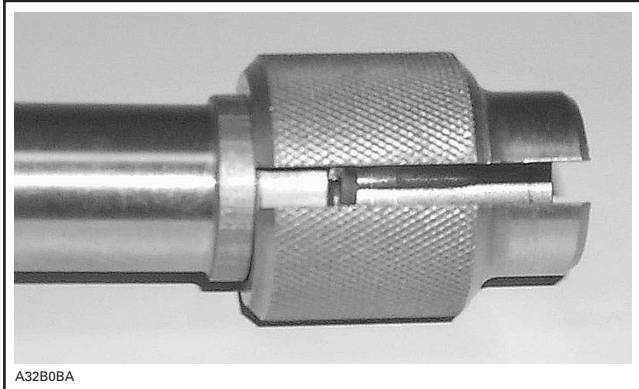

With the other end of the pusher, push circlip into the support groove.

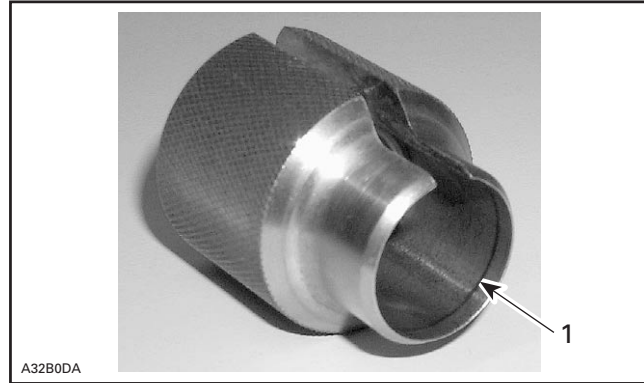
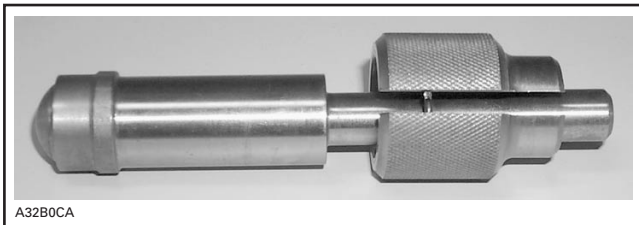

1. Groove



CIRCLIP READY TO BE INSTALLED ON PISTON

Using a plastic hammer, tap pusher to put circlip in place. Make sure to install new circlips with tab toward top as per following photo.

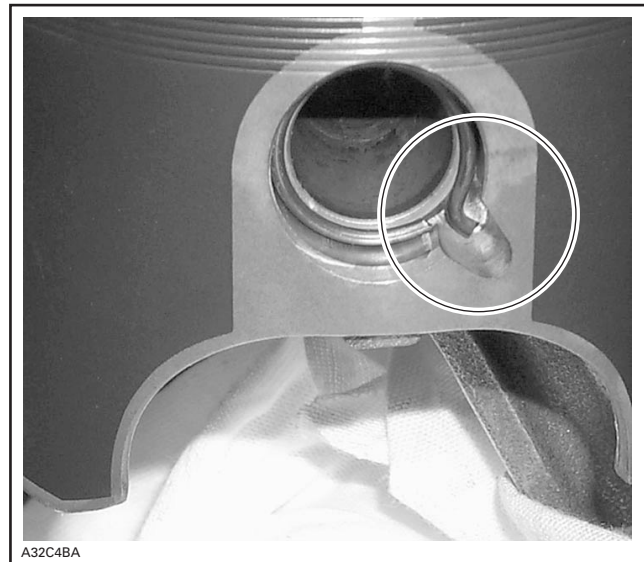

TAB TOWARD TOP

CAUTION: Always install new mono-hook circlips. If circlip installation fails at the first attempt, always retry with a new one because, on a second attempt, the circlip will lose its normal retaining capabilities.

CAUTION: Circlips must not move freely after installation; if so, replace them.

Before inserting piston in cylinder, lubricate the cylinder with new injection oil or equivalent.

Cylinder Head Cover, Cylinder Head and Cylinder

Apply a thin layer of Loctite 518 (P/N 293 800 038) to crankcase mating surface of base gasket. Choose the right gasket thickness according to combustion chamber volume. Refer to ENGINE MEASUREMENT. Install it on crankcase. Coat gasket with Loctite 518.

CAUTION: Always install a gasket of the proper thickness. Failure to do so may cause detonation and severe engine damage.

Before inserting piston in cylinder, lubricate the cylinder with new injection oil or equivalent.

Install cylinders. Do not tighten.

Install new rubber ring and round O-rings on each cylinder.

NOTE: Carefully clean screws before reinstallation, specifically under screw head.

Install exhaust manifold with gaskets. Do not tighten yet.

Torque cylinder screws in a crisscross sequence as per the following table.

M8	29 N•m (21 lbf•ft)
M10	40 N•m (29 lbf•ft)

At assembly, torque cylinder head screws to 29 N•m (21 lbf•ft) in the following illustrated sequence.

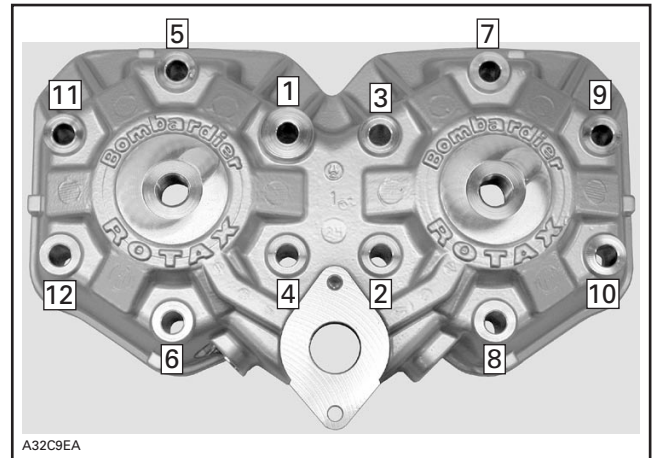

TYPICAL

Tighten exhaust manifold bolts in a criss-cross sequence.

Apply Loctite 243 (P/N 293 800 060) on screw threads. Install outlet socket and tighten screws. Note position of longer screw.

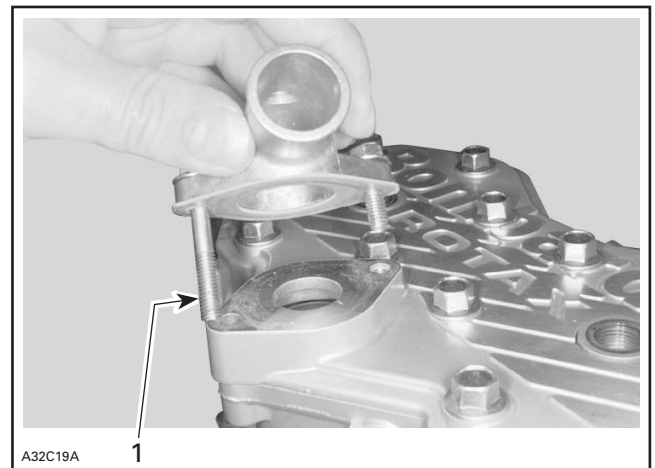

1. Longer screw

Reed Valve

Blades have a curved shape. Install with their curve facing reed block.

Check reed valve for proper tightness. There must not be any play between blade and valve body when exerting a finger pressure on blade at blade stopper location.

In case of a play, turn blade upside down and recheck. If there is still a play, replace blade and/or valve body.

Section 03 ENGINES

Subsection 05 (TOP END)

All Engines Except 793 HO

Check distance from blade stopper no. 29 outer edge and distance from center of reed valve block.

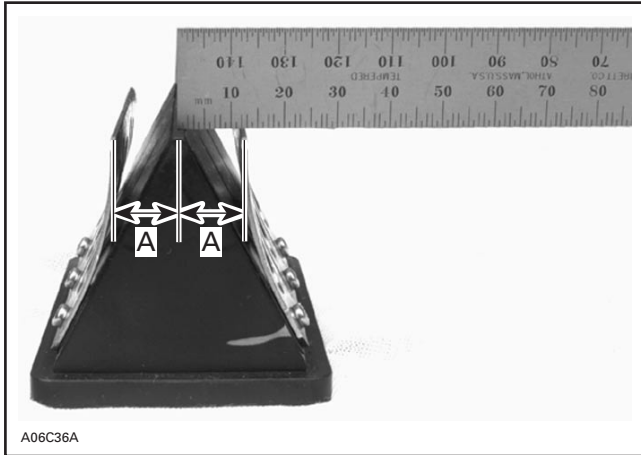

TYPICAL

A. 18.7 - 0, + 0.75 mm (.736 - 0, + .030 in)

Bent blade stopper as required to obtain the proper distance.

Blade stoppers may slightly interfere with cylinder during installation. Adjusted distance will be reduced automatically upon installation.

BOTTOM END

SERVICE TOOLS

Description	Part Number	Page
bearing heater.....	529 035 969	114, 124
bearing puller.....	420 877 635	112, 122
crankshaft protector	420 876 552	112, 122
crankshaft protector	420 876 557	113, 122
distance gauge	420 876 822	115
distance gauge	529 035 965	115
Distance gauge.....	529 035 966	125
Distance gauge.....	529 035 967	125
Distance gauge.....	529 035 968	125
feeler gauge.....	420 876 620	115
half rings	420 977 475	112
half rings	420 977 479	122
indicator stick.....	529 035 970	114
puller ring.....	420 977 490	112
puller ring.....	420 977 494	122
screws	420 840 681	112, 122
support plate.....	529 035 976	115, 125

SERVICE PRODUCTS

Description	Part Number	Page
anti-seize lubricant.....	413 701 000	113, 123
Bombardier Lube	293 600 016	122
Isoflex grease	293 550 021	117
Loctite 5910.....	293 800 081	117, 127
Loctite Chisel.....	413 708 500	112, 122
Petamo grease	420 899 271	123
pulley flange cleaner.....	413 711 809	113, 123
synthetic grease	413 711 500	112

Section 03 ENGINES

Subsection 06 (BOTTOM END)

377 Engine

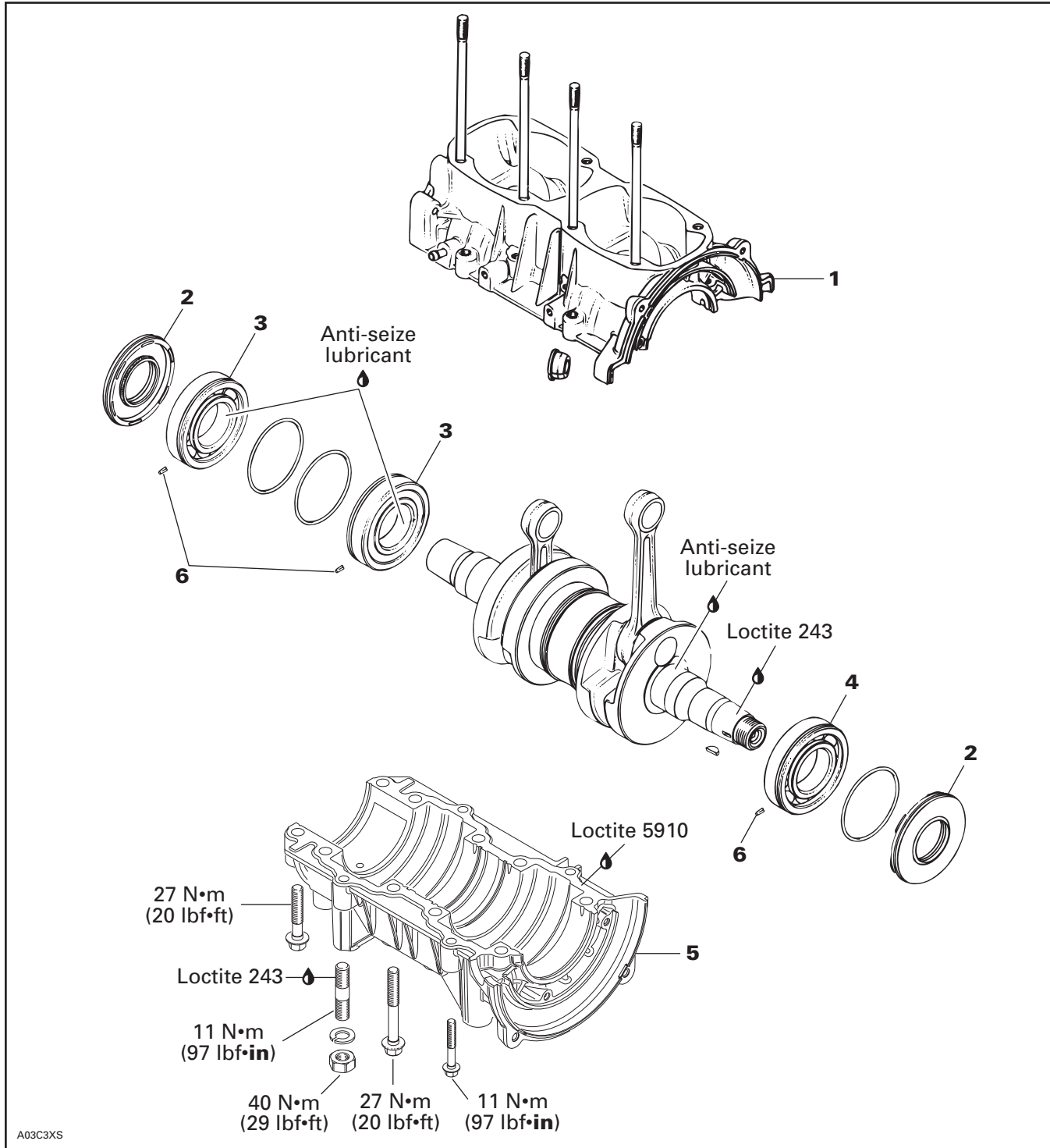

552 Engine

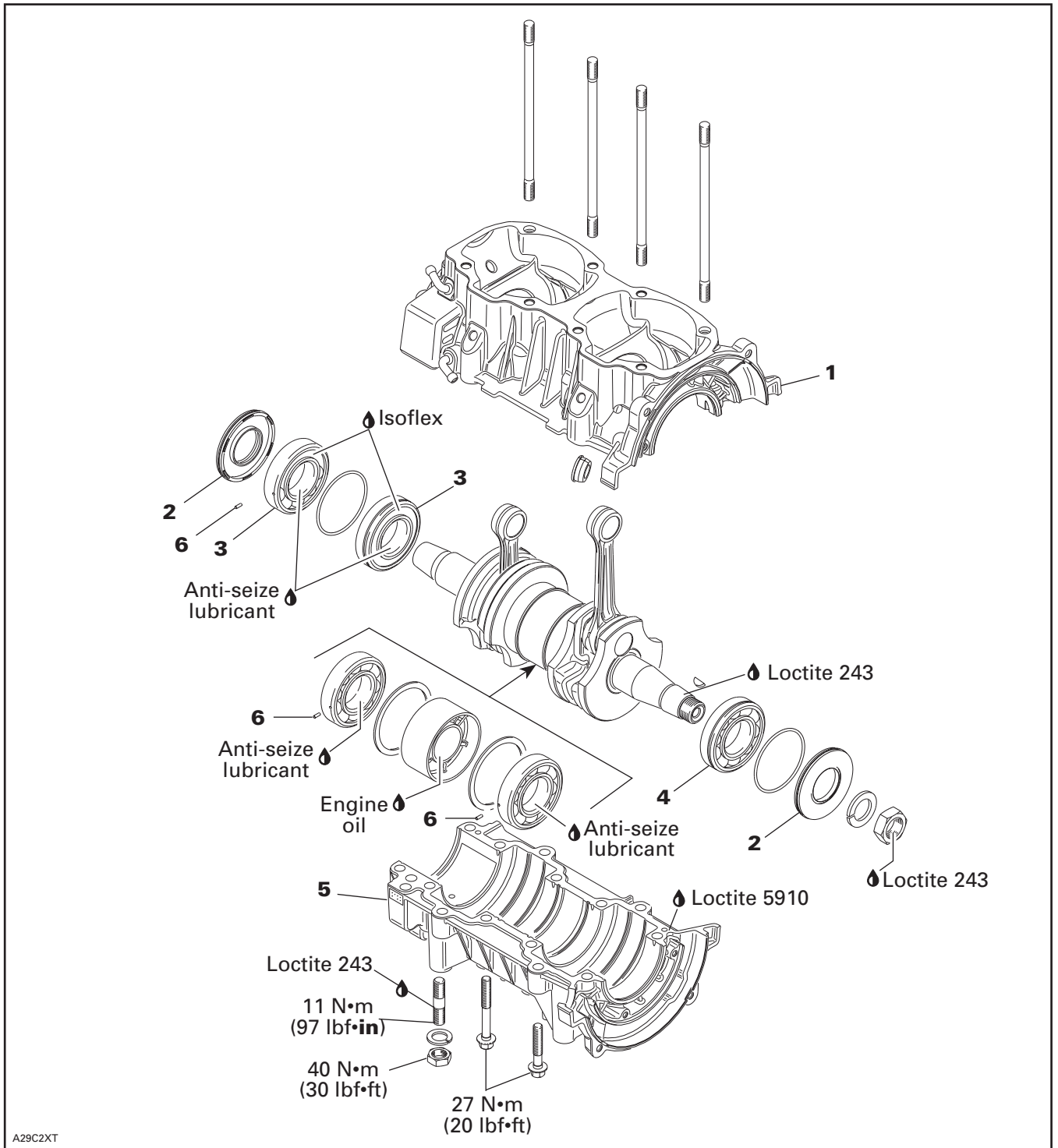

A29C2XT

Section 03 ENGINES

Subsection 06 (BOTTOM END)

Remove engine from chassis. Refer to REMOVAL AND INSTALLATION.

Remove engine fan cowls, cylinder heads and cylinders. Refer to TOP END.

Remove rewind starter. Refer to REWIND STARTER.

Remove fan belt pulley, trigger coils, magneto fly-wheel and stator plate. Refer to MAGNETO SYSTEM.

CLEANING

Discard all seals, gaskets and O-rings.

Clean all metal components in a non-ferrous metal cleaner. Use Loctite Chisel (P/N 413 708 500) accordingly.

Remove all trace of Loctite 243 from crankshaft taper.

Remove old sealant from crankcase mating surfaces with Loctite Chisel.

CAUTION: Never use a sharp object to scrape away old sealant as score marks incurred are detrimental to crankcase sealing.

DISASSEMBLY

To remove PTO side bearings **no. 3** from crankshaft, install half rings (P/N 420 977 475) and puller ring (P/N 420 977 490) on the bearing.

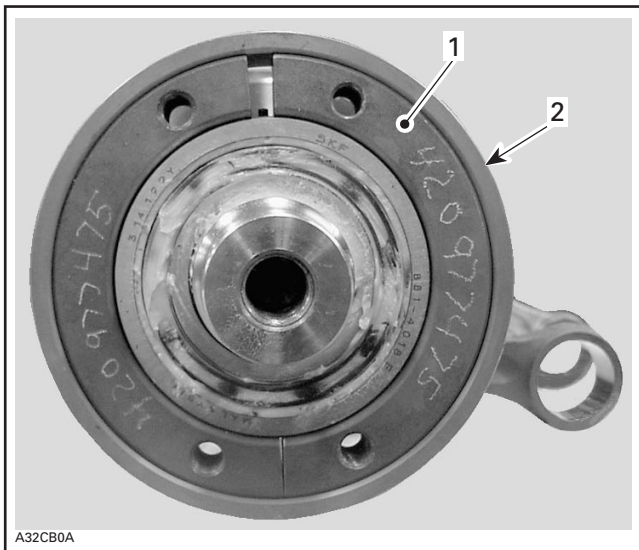

1. Half ring
2. Puller ring

Apply synthetic grease (P/N 413 711 500) on the crankshaft end and install crankshaft protector (P/N 420 876 552).

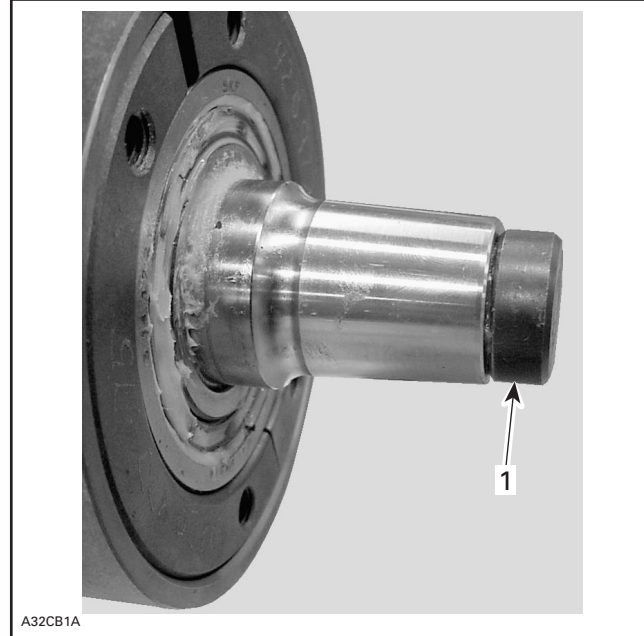

1. Crankshaft protector

Install bearing puller (P/N 420 877 635) and secure to half rings using screws (P/N 420 840 681).

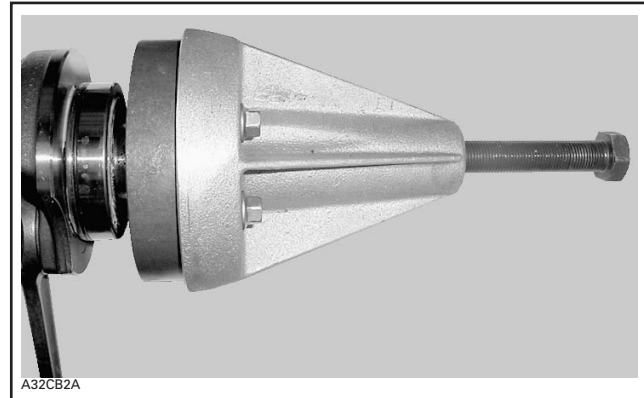

PULLER INSTALLED ON THE HALF RINGS

Secure the bearing puller in a vise by one of its rib.



BEARING PULLER SECURED IN THE VISE

CAUTION: Never use any air impact tool for tightening the puller bolt.

Lubricate the puller bolt and then proceed with tightening the puller bolt until the bearing comes out.

Follow the same procedure for the inner bearing.

NOTE: In the case of damaged bearing or less clearance between crankshaft counterbalance and the bearing or on the MAG side bearing, use bearing separator (SNAP-ON tool (P/N CJ951 or SPX/OTC) tool (P/N 1124) to facilitate the removal.

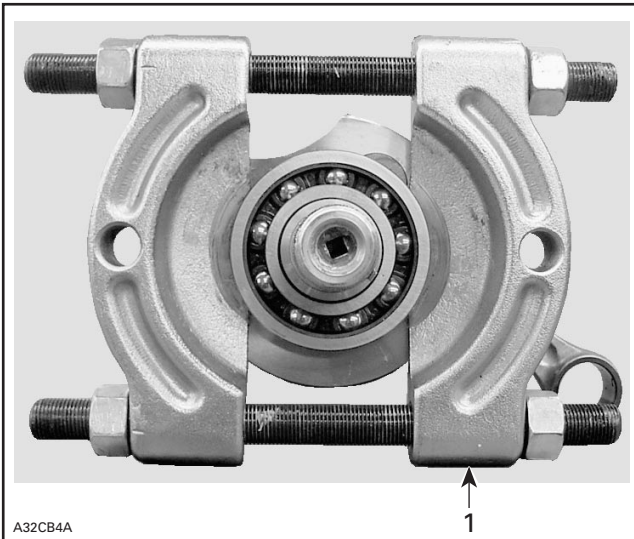

1. Bearing separator

Procedure for MAG side bearings **no. 4** is same as of PTO side with the exception of the crankshaft protector (P/N 420 876 557).

INSPECTION

Refer to table below to find bottom end engine dimension specifications. For dimension measurement procedures, refer to ENGINE MEASUREMENT.

ENGINE MEASUREMENT	TOLERANCES		
	NEW PARTS (min.)	(max.)	WEAR LIMIT
Crankshaft deflection on PTO side	N.A.	0.06 mm (.0024 in)	N.A.
Crankshaft deflection on MAG side	N.A.	0.03 mm (.001 in)	N.A.
Crankshaft Deflection in center of crankshaft	N.A.	0.08 mm (.0031 in)	N.A.
Connecting rod big end axial play	0.2 mm (.007 in)	0.53 mm (.026 in)	1.20 mm (.047 in)
Crankshaft end-play	0.10 mm (.004 in)	0.30 mm (.012 in)	N.A.

ASSEMBLY

Crankshaft Preparation

Clean crankshaft end with sand paper no. 180 and remove all residue using pulley flange cleaner (P/N 413 711 809).



Smear anti-seize lubricant (P/N 413 701 000) on part of crankshaft where bearing fits.

Section 03 ENGINES

Subsection 06 (BOTTOM END)



Crankshaft Bearing Preparation

Heat up the bearing(s) using bearing heater (P/N 529 035 969). This will expand bearings and ease installation. If required, put a suitable plate or shim to avoid the direct contact between integrated seal (if applicable) with the heating surface.



CAUTION: Bearing should not be heated to more than 80°C (176°F). Do not heat bearing with direct flame or heat gun or heated oil. Inappropriate heating procedure(s) may cause inner seal failure.

Turn bearing(s) several times during heating process for heating it (them) properly.

NOTE: Normally it takes approximately 10 minutes to heat up a bearing so in the event of replacing bearing, it's recommended to start the bearing heating process prior to removal operation. Two bearings can be heated at the same time on one bearing heater.



1. Bearings

Touch the inner race of the bearing with the temperature indicator stick (P/N 529 035 970). Stick will liquefy when the bearing reach the proper temperature.

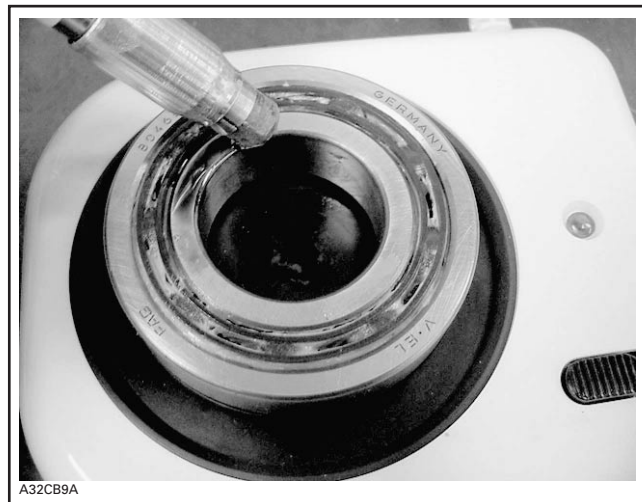

⚠ WARNING

Do not touch heated bearing with bare hands. Wear heat resisting gloves before handling the heated bearing(s).

Crankshaft Bearing Installation

377 Engine

To check proper clearance between bearing no. 3 and crankshaft counterbalance, use feeler gauge (P/N 420 876 620).

Mount second bearing with distance gauge (P/N 420 876 822) for proper positioning.

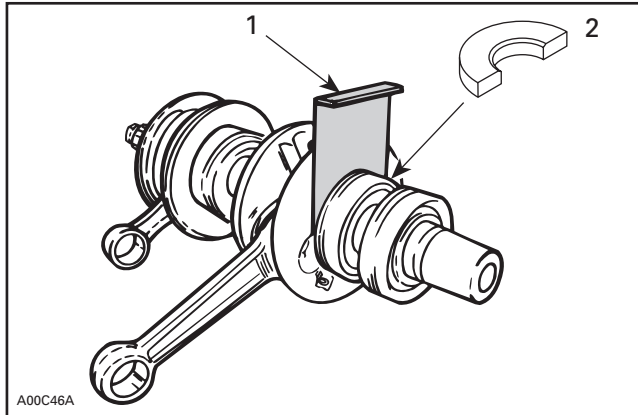

1. Feeler gauge
2. Distance gauge

552 Engine

Slide in the inner PTO bearing with the integrated seal facing crankshaft. Push bearing to end position.

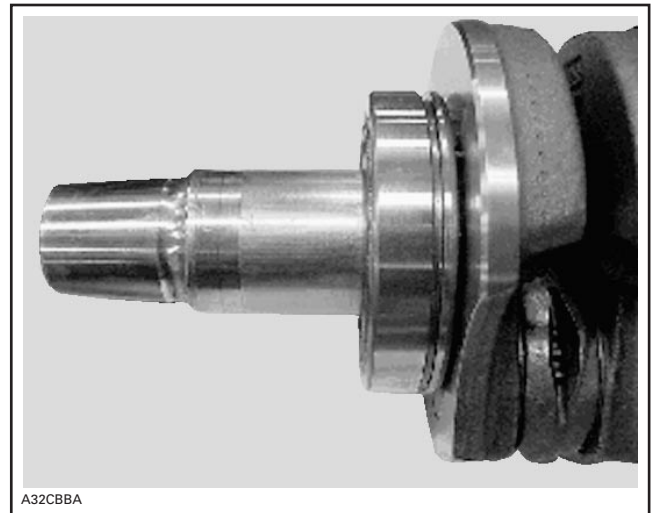

BEARING TO END POSITION

Install the O-ring.

Make a bearing locator tool using support plate (P/N 529 035 976) and distance gauge (P/N 529 035 965).

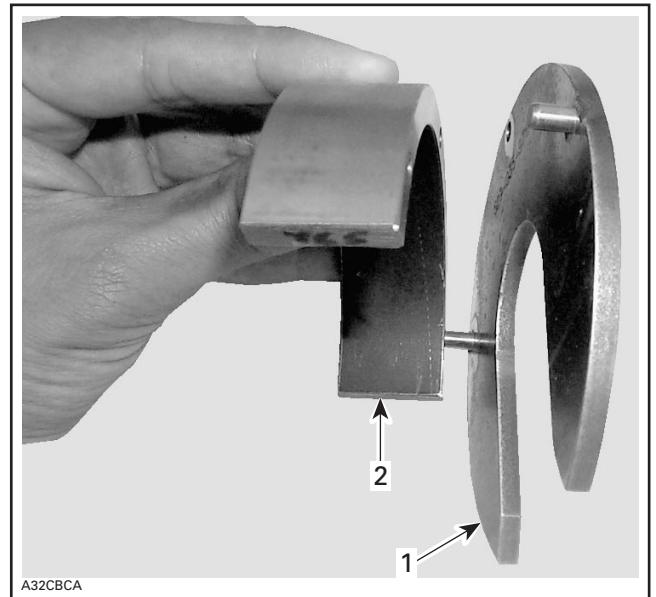

1. Support plate
2. Distance gauge

Install bearing locator tool.

Section 03 ENGINES

Subsection 06 (BOTTOM END)



Slide in the heated outer PTO bearing onto the crankshaft.



Install the MAG side heated bearing.

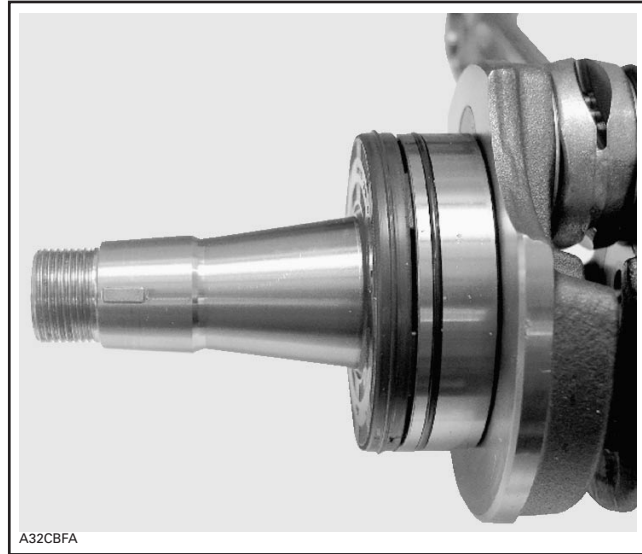

Crankshaft Installation

When installing crankshaft, position drive pins no. 6 as illustrated.

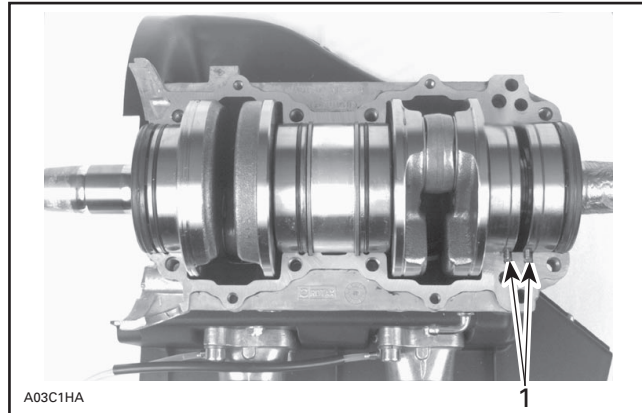

TYPICAL
1. Drive pins

At seal no. 2 assembly, apply a light coat of lithium grease on seal lip.

377 Engine

For bearing lubrication purpose, a gap of 1.0 mm (.040 in) must be maintained between seals and bearings.

When installing plain oil seals (seal without locating ring or without spacing legs), ensure to maintain 1.0 mm (.040 in) gap.

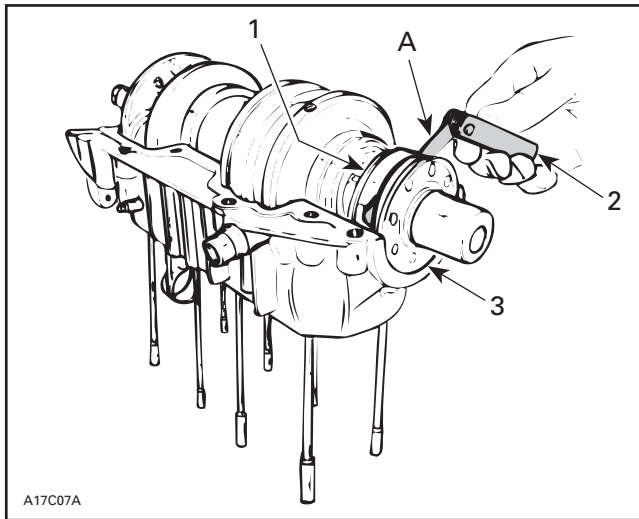

- 1. Bearing
- 2. Feeler gauge
- 3. Plain oil seal
- A. 1 mm (.040 in)

552 Engine

Put 27 to 32 mL of grease in a syringe.

With the syringe, fill in the PTO side ball bearings of Isoflex grease as shown below.

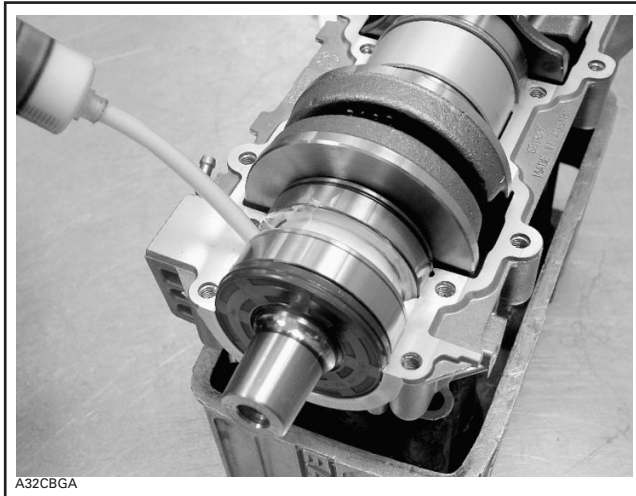

TYPICAL — BALLS COATED WITH A SEAM OF GREASE

CAUTION: Use only the recommended Isoflex grease (P/N 293 550 021). Make sure not to push Isoflex grease between outside bearing race and half crankcase.

Crankcase Assembly

Crankcase halves nos.1 and 5 are factory matched and therefore, are not interchangeable as single halves.

IMPORTANT: The total assembly sequence, including sealing compound spreading, screwing and torquing of bolts according to the proper sequence must be performed within 10 minutes. Do not wait between each bolt torquing. All bolts must be torqued in a row.

Before screwing both parts of crankcase, seal it with Loctite 5910 (P/N 293 800 081).

NOTE: It is recommended to apply this specific sealant as described here to get an uniform application without lumps. If you do not use the roller method, you may use your finger to uniformly distribute the sealant.

CAUTION: Do not use Loctite Primer N with the Loctite 5910. Using these products or non silicone-based sealant over a previously sealed crankcase with Loctite 5910 will lead to poor adhesion and possibly a leaking crankcase. These products are chemically incompatible. Even after cleaning, the Loctite 5910 would leave incompatible microscopic particles.

Use a plexiglass plate and apply some sealant on it. Use a soft rubber roller (50 - 75 mm (2 - 3 in)) (available in arts products suppliers for printmaking) and roll the sealant to get a thin uniform coat on the plate (spread as necessary). When ready, apply the sealant on crankcase mating surfaces.

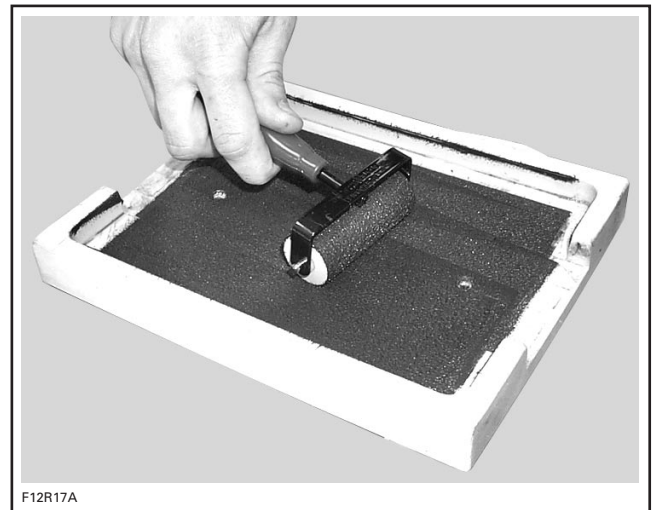

Section 03 ENGINES

Subsection 06 (BOTTOM END)

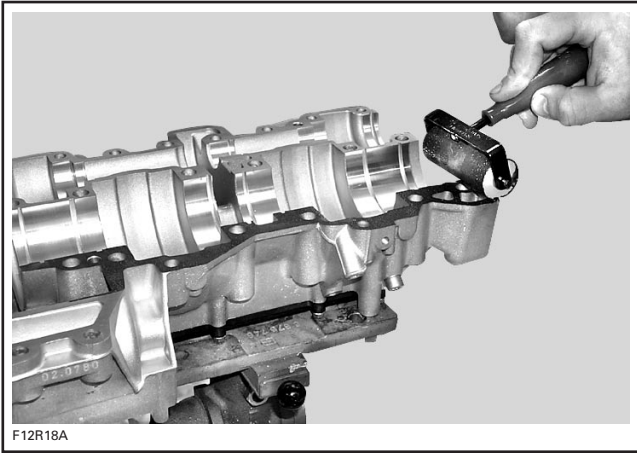

TYPICAL

Screw all crankcase bolts in place in the following sequence and to the appropriate torque through a two steps torquing: first, screw bolts up to 60% of the final torque 13 N•m (115 lbf•in) for M8 bolts), then, tighten to the required torque (i.e. 22 N•m (16 lbf•ft).

377 Engine

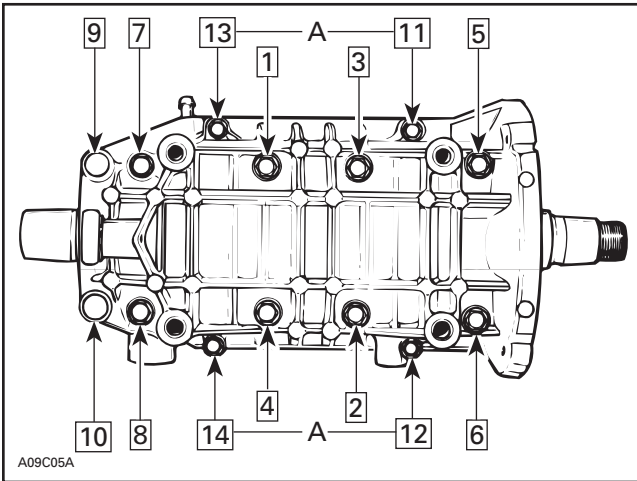

TIGHTENING SEQUENCE FOR 377 ENGINE TYPE

A. 10 N•m (89 lbf•in)

All the other screws are torqued to 22 N•m (16 lbf•ft)

552 Engine

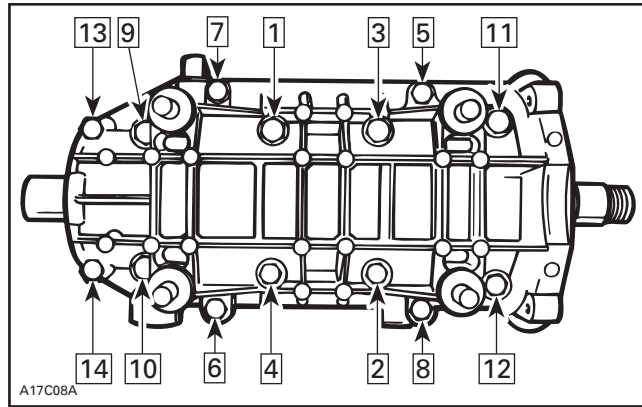

TIGHTENING SEQUENCE FOR 552 ENGINE TYPE

BREAK-IN

After rebuilding an engine always observe a break-in period as described in *Operator's Guide*.

Section 03 ENGINES
Subsection 06 (BOTTOM END)

593 Engine

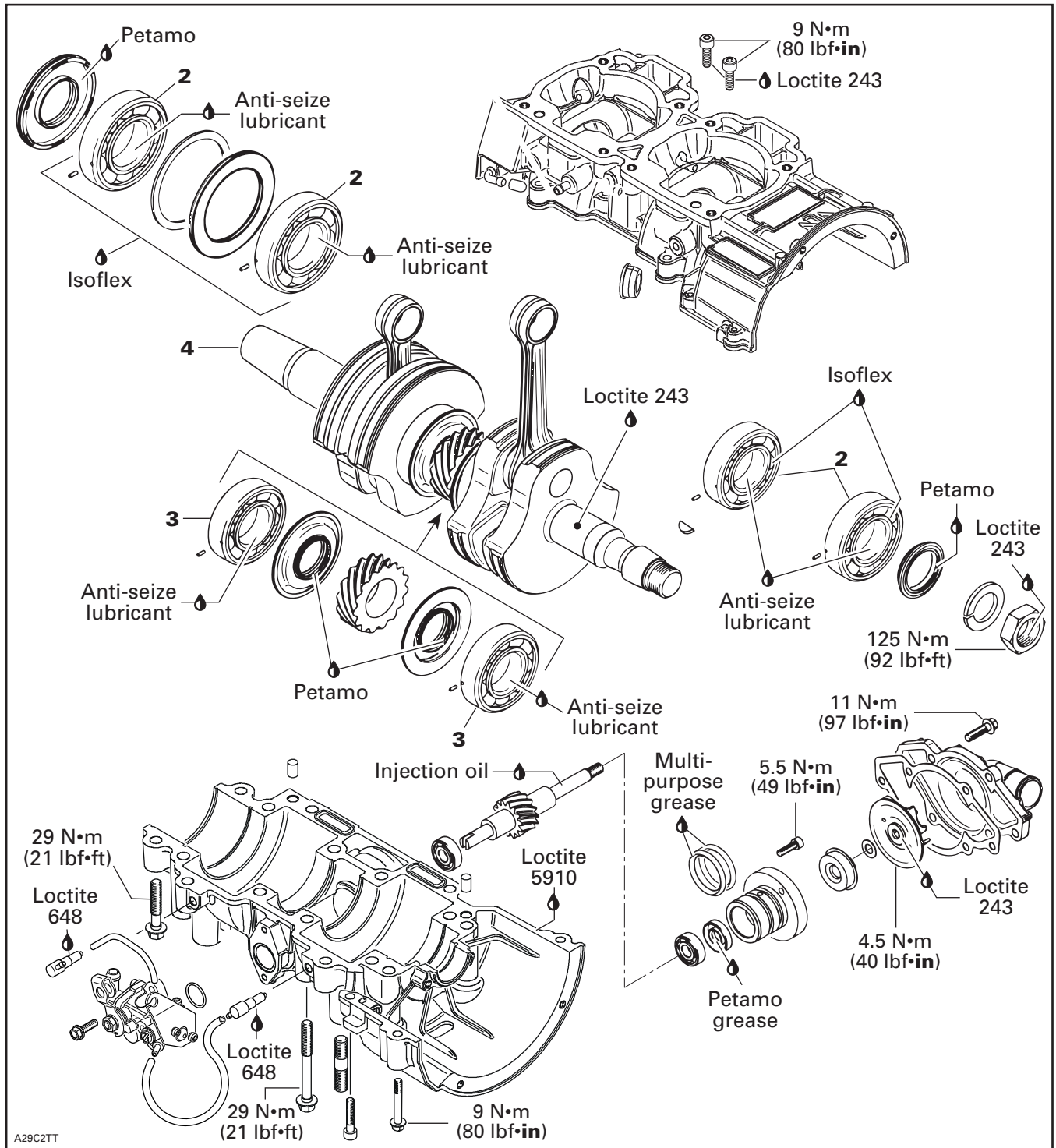

Section 03 ENGINES

Subsection 06 (BOTTOM END)

593 HO Engine

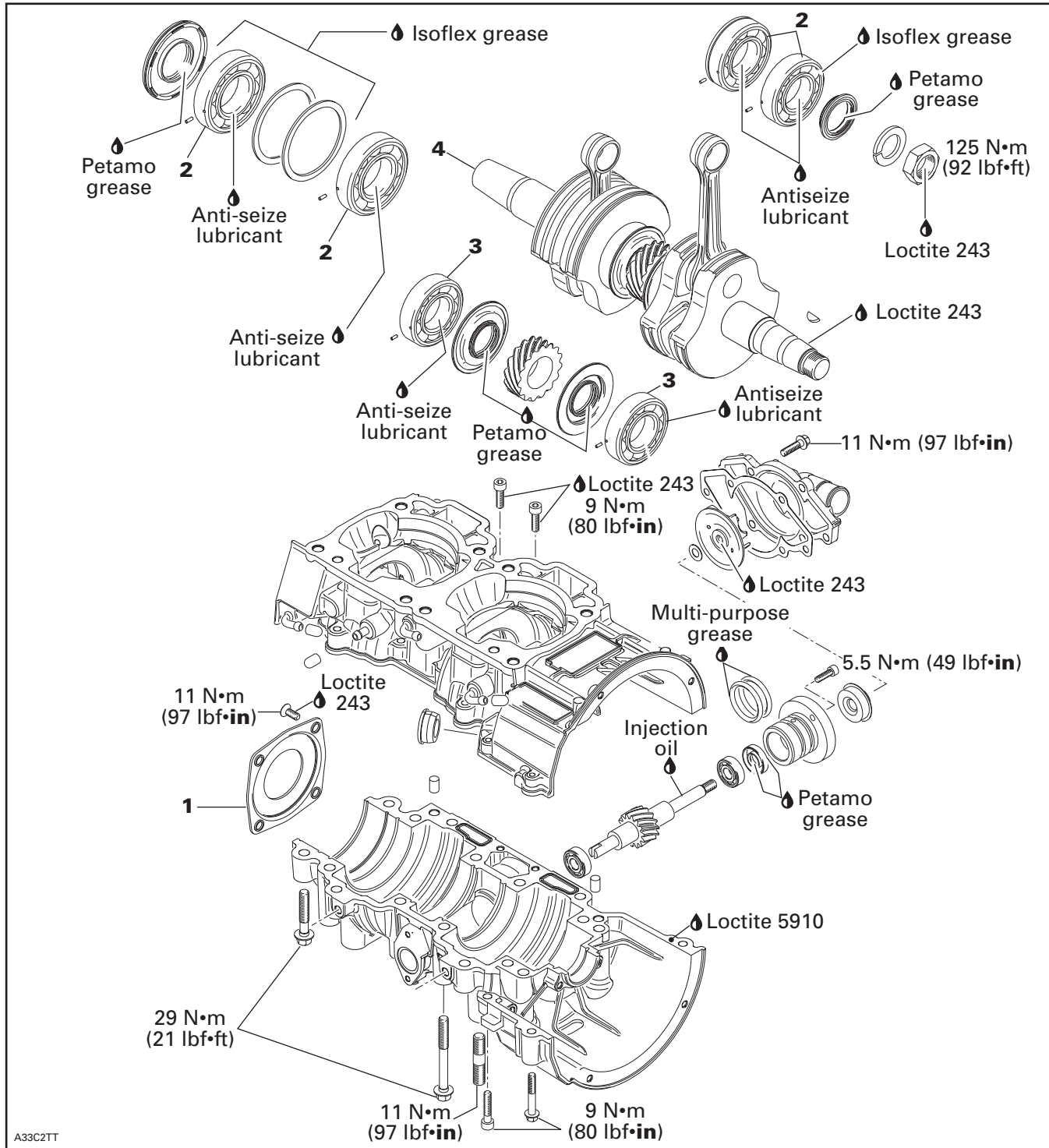

A33C2TT

Section 03 ENGINES
Subsection 06 (BOTTOM END)

593 HO SDI and 793 HO Engines

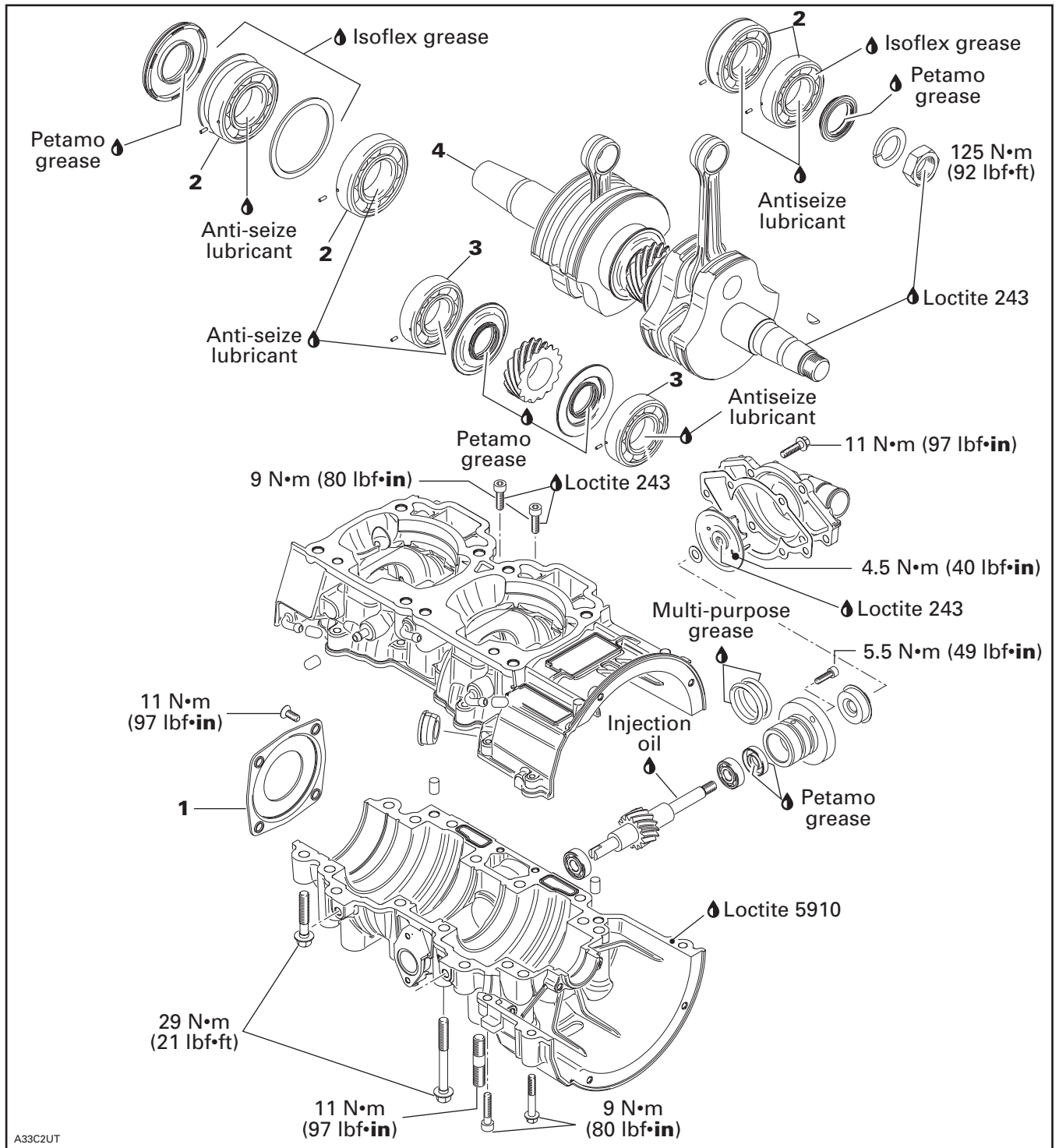

Section 03 ENGINES

Subsection 06 (BOTTOM END)

CLEANING

Discard all oil seals, gaskets, O-rings and sealing rings.

Clean all metal components in a non-ferrous metal cleaner. Use Loctite Chisel (P/N 413 708 500) accordingly.

Remove old paste gasket from crankcase mating surfaces using also Loctite Chisel.

CAUTION: Never use a sharp object to scrape away old sealant as score marks incurred are harmful to crankcase sealing.

DISASSEMBLY

General

Remove cylinder head and cylinder. Refer to TOP END.

Remove rewind starter. Refer to REWIND STARTER.

Remove trigger coils, magneto flywheel and stator. Refer to MAGNETO SYSTEM.

593 HO, 593 SDI and 793 HO Engines

Remove oil seal cover no. 1.

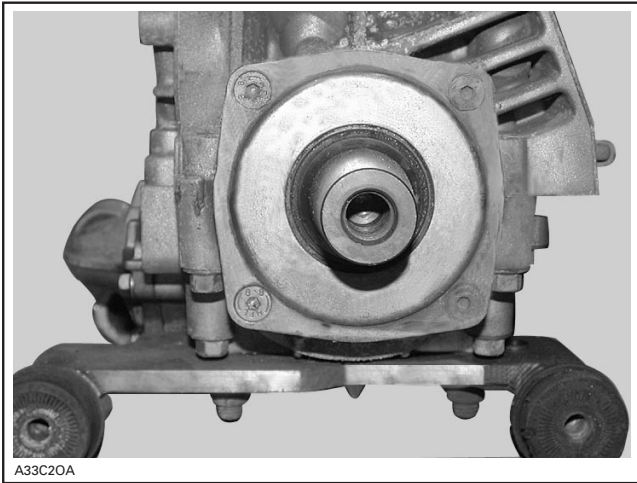

TYPICAL

Crankshaft Bearing

To remove bearings no. 2 and no. 3 from crankshaft no. 4, install half rings (P/N 420 977 479) and puller ring (P/N 420 977 494) on the outer bearing.

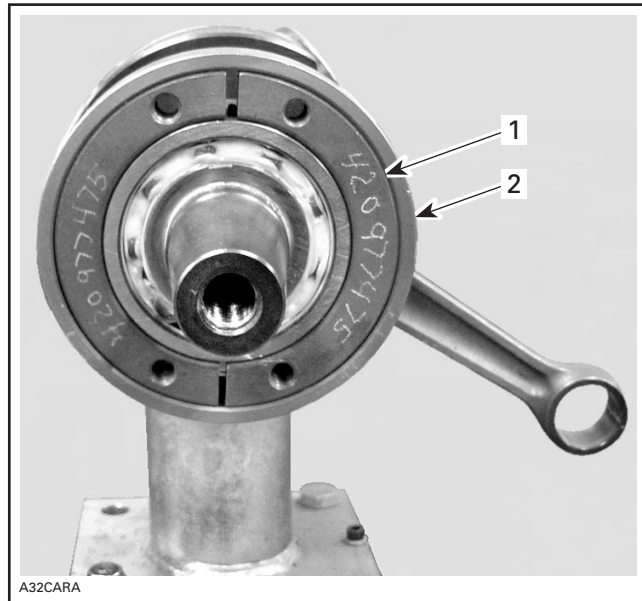

1. Half ring
2. Puller ring

NOTE: Apply grease on crankshaft end in order to hold in place the crankshaft protector (P/N 420 876 552) on PTO side and crankshaft protector (P/N 420 876 557) on MAG side.

Using screws (P/N 420 840 681), install bearing puller (P/N 420 877 635) on the half rings.

Secure the bearing puller in a vise by one of its rib.



BEARING PULLER SECURED IN THE VISE

CAUTION: Never use any air impact tool for tightening the puller bolt. Lubricate the bolt with Bombardier Lube (P/N 293 600 016) to avoid damaging the threads.

Screw in the puller bolt until the bearing comes out.

Follow the same procedure for the inner bearing

NOTE: In the case of damaged bearing or less clearance between crankshaft counterbalance and the bearing or on the MAG side bearing, use a bearing separator such as Snap-On tool CJ 951 or SPX/OTC tool 1124 to facilitate the removal.

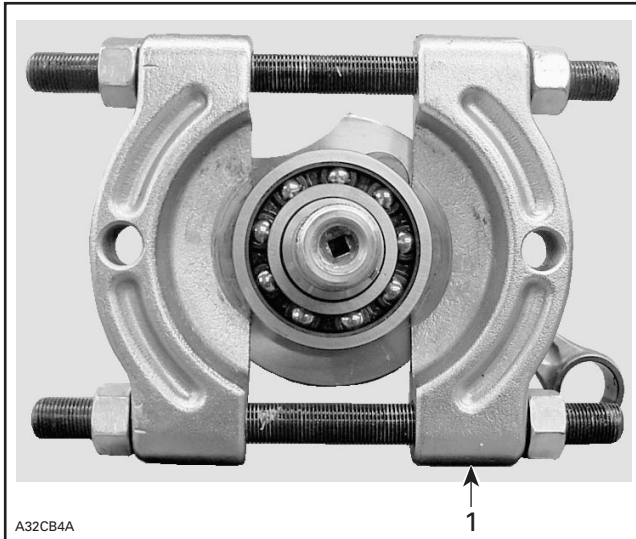

1. Bearing separator

INSPECTION

Refer to table below to find bottom end engine dimension specifications. For dimension measurement procedures, refer to ENGINE MEASUREMENT.

ENGINE MEASUREMENT	TOLERANCES		
	NEW PARTS (min.)	(max.)	WEAR LIMIT
Crankshaft deflection on PTO side	N.A.	0.06 mm (.0024 in)	N.A.
Crankshaft deflection on MAG side	N.A.	0.05 mm (.002 in)	N.A.
Crankshaft Deflection in center of crankshaft	N.A.	0.08 mm (.0031 in)	N.A.
Connecting rod big end axial play	0.39 mm (.015 in)	0.74 mm (.029 in)	1.20 mm (.047 in)
Crankshaft end-play	0.10 mm (.004 in)	0.30 mm (.012 in)	N.A.

ASSEMBLY

Coat lip of all seals with Petamo grease (P/N 420 899 271).

Crankshaft Preparation

Inspect crankshaft ends for damage.

Clean crankshaft ends with sand paper no. 180 to remove possible seal marks and debris.



A32CB5A



A32CBWB

Remove all residue using pulley flange cleaner (P/N 413 711 809).

Smear anti-seize lubricant (P/N 413 701 000) on part of crankshaft where bearing fits.

Section 03 ENGINES

Subsection 06 (BOTTOM END)

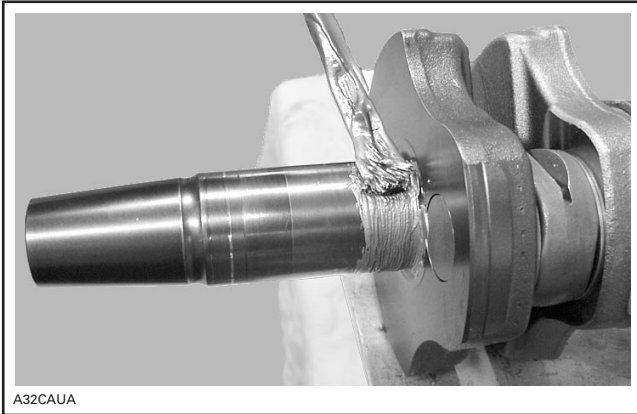

Crankshaft Bearing Preparation

Heat up the bearing(s) using bearing heater (P/N 529 035 969). This will expand bearings and ease installation. If required, put a suitable plate or shim to avoid the direct contact between integrated seal with the heating surface.



CAUTION: Bearing(s) should not be heated to more than 80°C (176°F). Do not heat bearing(s) on direct flame, or with a heat gun or in an oil bath. Inappropriate bearing(s) heating may result in inner seals or cage failure.

Turn bearing several times to obtain an even heating process.

NOTE: Normally it takes approximately 10 minutes to heat up a bearing so in the event of replacing bearing, it's recommended to start the bearing heating process prior to removal operation. Two bearings can be heated at the same time on one bearing heater.



1. Bearings

Probe the inner race of the bearing with the temperature indicator stick (P/N 529 035 970). Stick will liquefy when the bearing reach the proper temperature

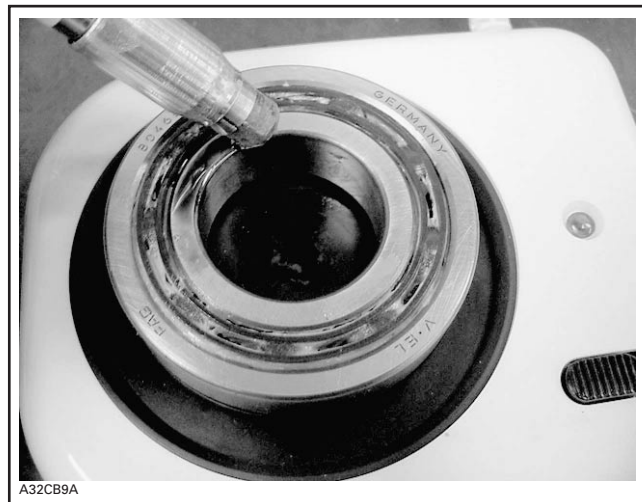

⚠ WARNING

Do not touch heated bearing with bare hands. Always wear heat resisting gloves before handling the heated bearing(s).

Crankshaft Bearing Installation

CAUTION: Never reinstall a bearing that has been removed.

Slide in the inner PTO bearing with the integrated seal facing crankshaft. Push bearing to end position.



NOTE: Heated bearings will slide onto the crankshaft. If required, push with a steel tube on the inner ring of the bearing. **Pay special attention to correct positioning of the drive pins and/or retaining discs.**

Install retaining discs.

Install support plate (P/N 529 035 976) with appropriate distance gauge; refer to following table.

TOOL	ENGINE
Distance gauge (P/N 529 035 966)	593
Distance gauge (P/N 529 035 967)	593 HO
Distance gauge (P/N 529 035 968)	593 HO SDI and 793 HO

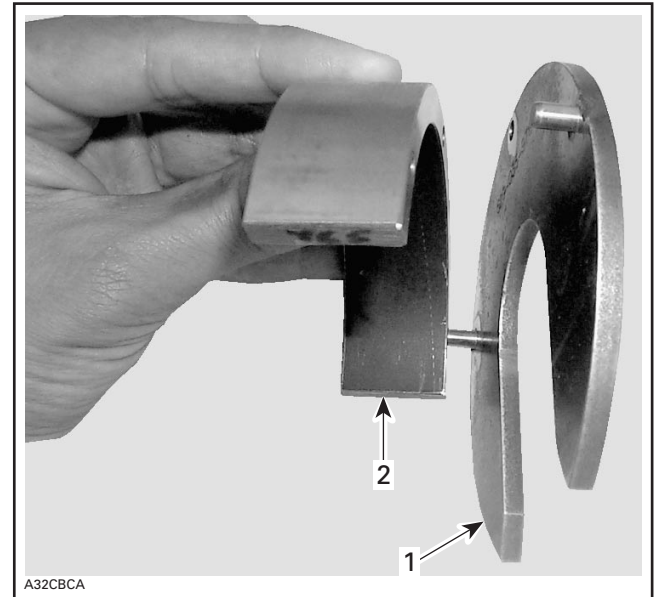

1. Support plate
2. Distance gauge

Install bearing locator tool.

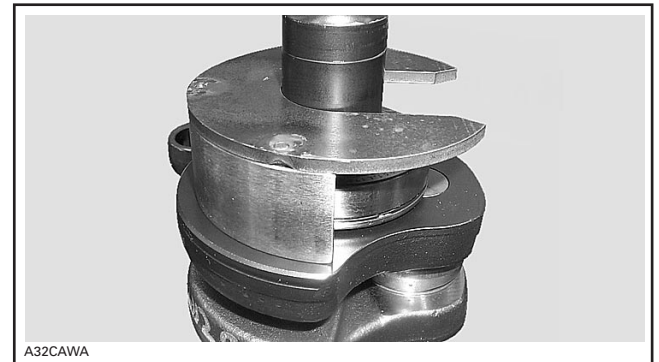

Slide in the heated outer PTO bearing onto the crankshaft until it contacts the distance gauge.

Slide-in the first MAG bearing **with the integrated seal facing crankshaft**. Push bearing to the bottom with pusher, using a rubber hammer.

Section 03 ENGINES

Subsection 06 (BOTTOM END)



Slide-in the second bearing until it contacts the first one.



Crankshaft Installation

At crankshaft installation, position drive pins as illustrated.

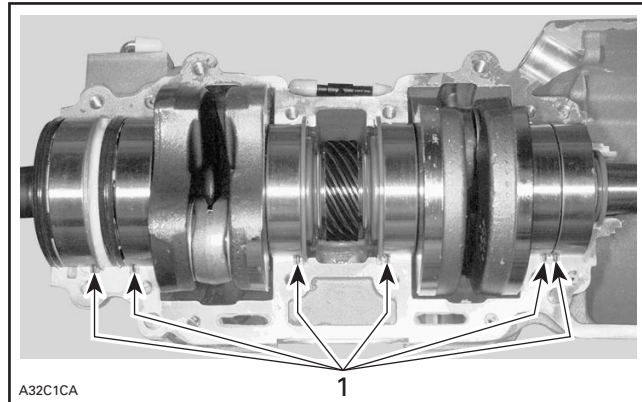

TYPICAL

1. Position pins

Pour 50 mL (2 U.S. oz) of injection oil in the pan under central gear to lubricate pump gearing as per photo.

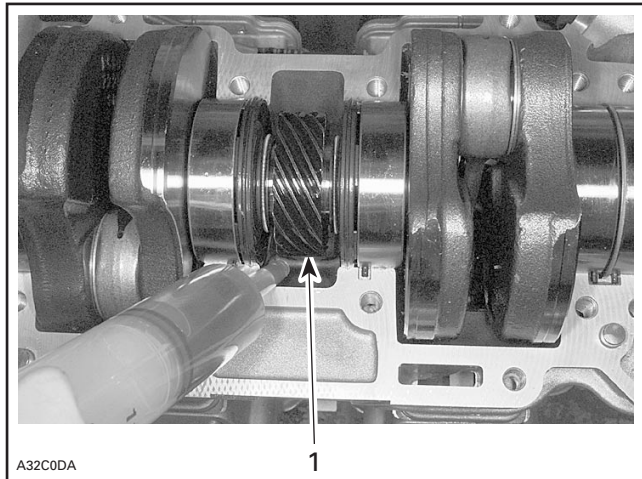

1. Oil bath

Apply Isoflex grease as per following procedure:

CAUTION: Use only the recommended Isoflex grease. Make sure not to push Isoflex grease between outside bearing race and half crankcase.

NOTE: The 50 g tube corresponds to 50 cc of grease.

Put 50 to 55 mL of grease in a syringe.

CAUTION: Do not exceed the recommended amount of grease

Fill inner side of PTO side bearing with Isoflex grease (about 10 mL).

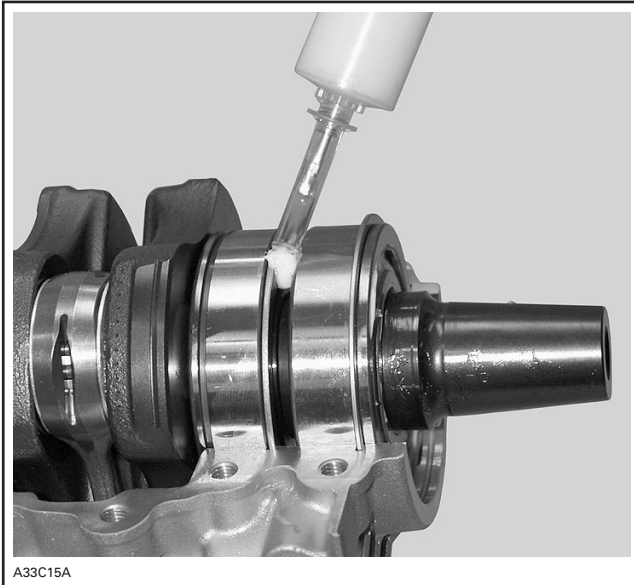

PTO SIDE BEARING FILLED WITH ISOFLEX GREASE

With the syringe, fill the outer ball bearing and inner side of outer seal with 40 to 45 mL of Isoflex grease.



BALLS COATED WITH A SEAM OF GREASE

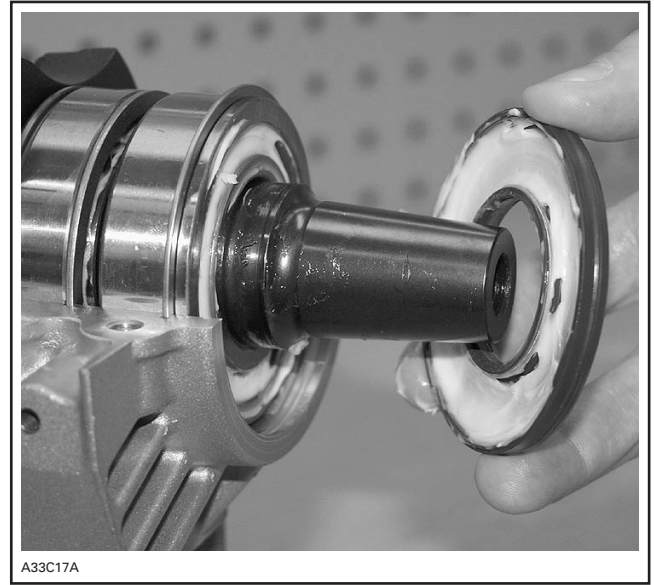

TYPICAL — FILL WITH GREASE AND SET IN PLACE

Apply 6 mL of grease to MAG side outer bearing.

NOTE: If replaced with new bearing, do not apply grease as new bearings come with grease already applied.

Crankcase Assembly

IMPORTANT: The total assembly sequence, including sealing compound spreading, screwing and torquing of bolts according to the proper sequence, must be performed within 10 minutes. Do not wait between each bolt torquing. All bolts must be torqued in a row.

Before screwing both parts of crankcase, seal it with a Loctite 5910 (P/N 293 800 081).

NOTE: It is recommended to apply this specific sealant as described here to get an uniform application without lumps. If you do not use the roller method, you may use your finger to uniformly distribute the sealant.

CAUTION: Do not use Loctite Primer N with the Loctite 5910. Using these products or non silicone-based sealant over a previously sealed crankcase with Loctite 5910 will lead to poor adhesion and possibly a leaking crankcase. These products are chemically incompatible. Even after cleaning, the Loctite 5910 would leave incompatible microscopic particles.

Section 03 ENGINES

Subsection 06 (BOTTOM END)

Use a plexiglass plate and apply some sealant on it. Use a soft rubber roller (50 - 75 mm (2 - 3 in)) (available in arts products suppliers for printmaking) and roll the sealant to get a thin uniform coat on the plate (spread as necessary). When ready, apply the sealant on crankcase mating surfaces.

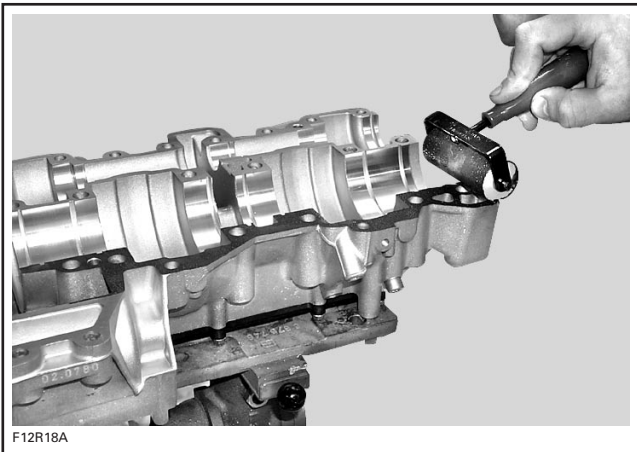
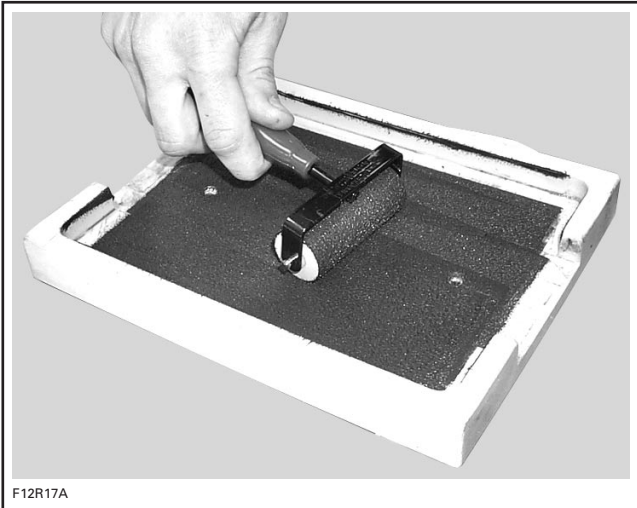

Screw all crankcase bolts in place in the following sequence and to the appropriate torque; this must be done in two steps torquing: first, screw bolts up to 60% of the final torque (18 N•m (13.5 lbf•ft) for most of the bolts), then, tighten to the required torque (i.e. 29 N•m (21 lbf•ft)).

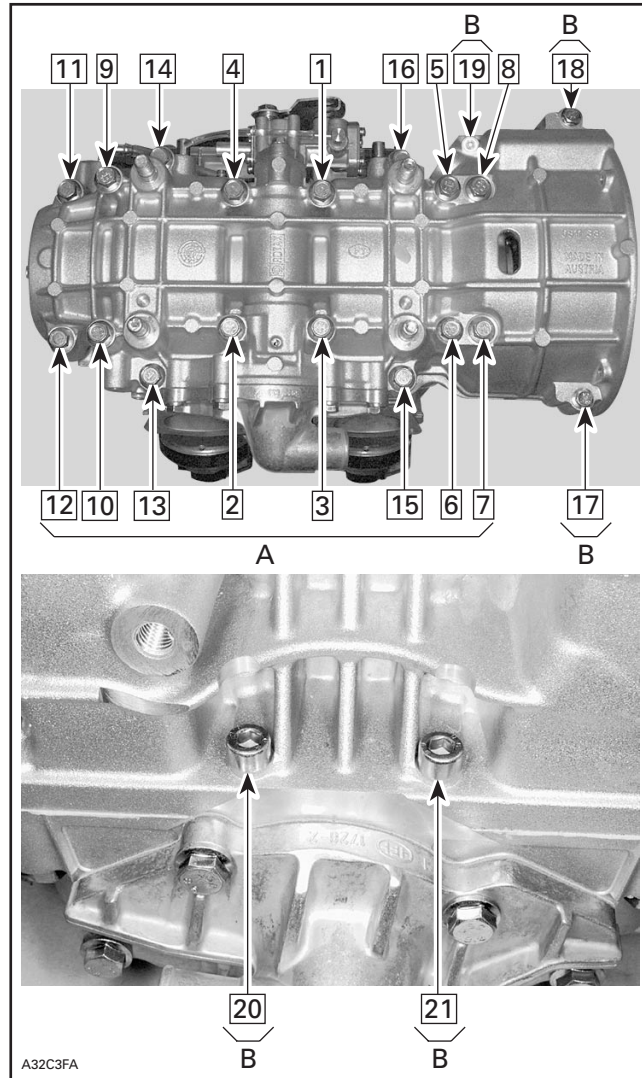

- A. Torque bolts 1 through 16 to 29 N•m (21 lbf•ft)
- B. Torque bolts 17 through 21 to 9 N•m (80 lbf•in)

593 HO, 593 HO SDI and 793 HO Engines

Install oil seal cover.

BREAK-IN

After rebuilding an engine, always observe a break-in period as described in *Operator's Guide*.

ENGINE MEASUREMENT

SERVICE TOOLS

Description	Part Number	Page
degree wheel	529 035 607	134
TDC gauge	414 104 700	130, 134

NOTE: This subsection explains the procedures to correctly measure engine components. For the engine technical specifications, refer to INSPECTION in the appropriate engine subsection.

CYLINDER HEAD WARPAGE

Check gasketed surface of the cylinder head with a straightedge and a feeler gauge. Make sure part is within the given specification. If cylinder head is out of specification, replace it. Verify combustion chamber volume to use the correct cylinder base gasket with the new part.

CYLINDER TAPER

Compare cylinder diameter 16 mm (5/8 in) from top of cylinder to just below its intake port area.

If the difference exceeds the specified dimension the cylinder should be rebored and honed or should be replaced. Nikasil cylinder can be honed using diamond hone but can not be rebored.

NOTE: Be sure to restore the chamfer around all cylinder sleeve port openings.

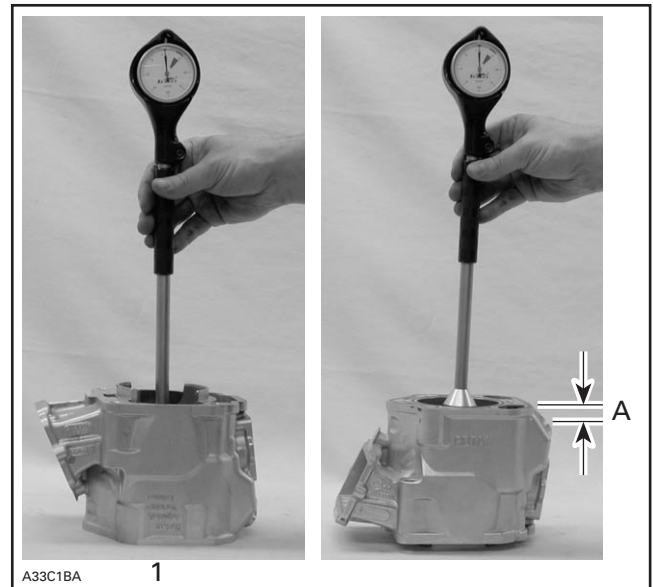

1. Below the intake port
A. 16 mm (5/8 in) from top

CYLINDER OUT OF ROUND

Measuring 16 mm (5/8 in) from top of cylinder with a cylinder gauge, check if the cylinder out of round is more than the specified dimension. If larger, cylinder should be rebored and honed or should be replaced. Nikasil cylinder can be honed using diamond hone but cannot be rebored.

NOTE: Be sure to restore the chamfer around all cylinder sleeve port openings.

Section 03 ENGINES

Subsection 07 (ENGINE MEASUREMENT)

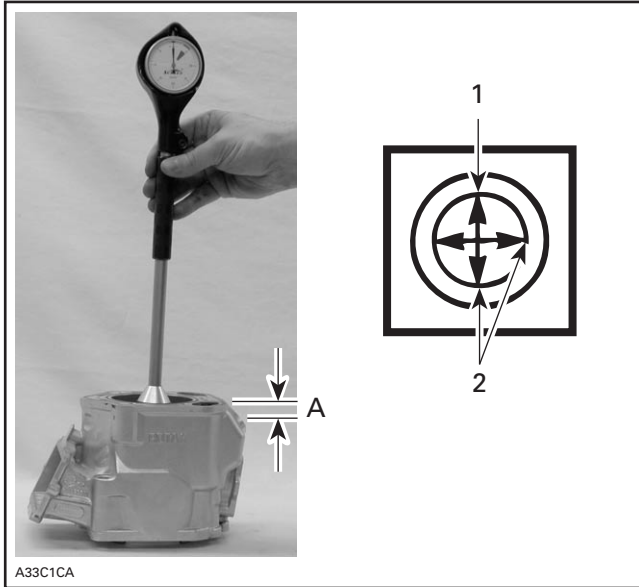

1. Piston pin position
 2. Measures to be compared
- A. 16 mm (5/8 in)

COMBUSTION CHAMBER VOLUME MEASUREMENT

The combustion chamber volume is the region in the cylinder head above the piston at Top Dead Center. It is measured with the cylinder head installed on the engine.

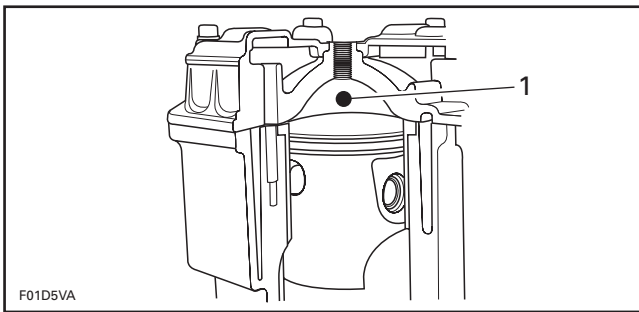

1. Combustion chamber

NOTE: When checking the combustion chamber volume, engine must be cold, piston must be free of carbon deposits and cylinder head must be leveled.

- Remove both spark plugs and bring one piston to Top Dead Center using a TDC gauge (P/N 414 104 700).

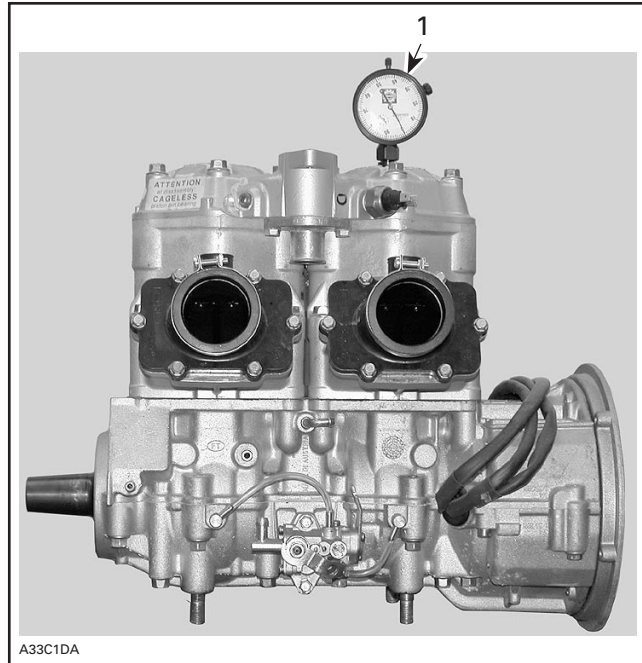

1. Bring piston to TDC

- Obtain a graduated burette (capacity 0 - 50 cc) and fill with an equal part (50/50) of gasoline and injection oil.

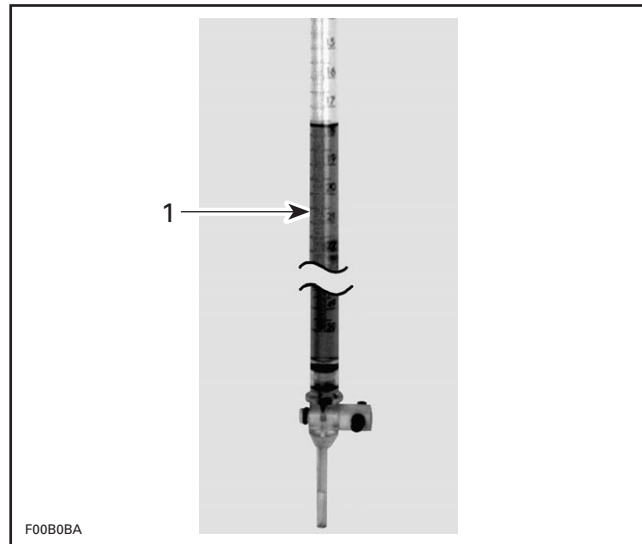

1. Graduated burette (0 - 50 cc)

- Open burette valve to fill its tip. Add liquid in burette until level reaches 0 cc.
- Inject the burette content through the spark plug hole until liquid touches the top spark plug hole.

Section 03 ENGINES

Subsection 07 (ENGINE MEASUREMENT)

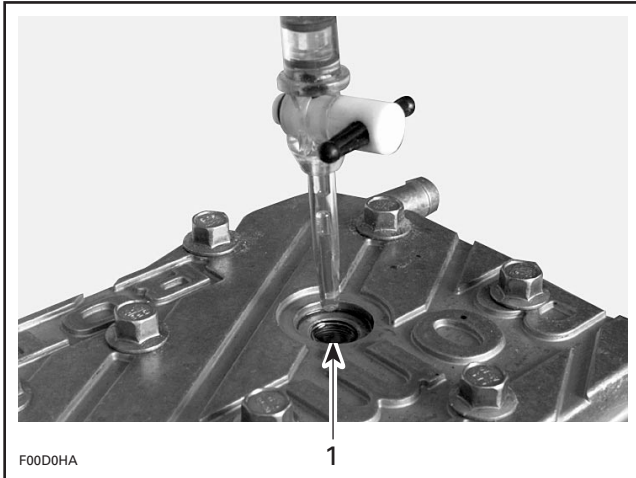

1. Top of spark plug hole

NOTE: The liquid level in cylinder must not drop for a few seconds after filling. If so, there is a leak between piston and cylinder. The recorded volume would be false.

- Let burette stand upward for about 10 minutes, until liquid level is stabilized.
- Read the burette scale to obtain the quantity of liquid injected in the combustion chamber.

NOTE: When the combustion chamber is filled to top of spark plug hole, it includes an amount of 2.25 cc corresponding to the spark plug well.

- Repeat the procedure for the other cylinder.
- Install a thicker or thinner cylinder/crankcase gasket (refer to *Parts Catalogs*) in order to obtain the specified combustion chamber volume or the nearest.

USED PISTON MEASUREMENT

Note the measurement on the piston dome.

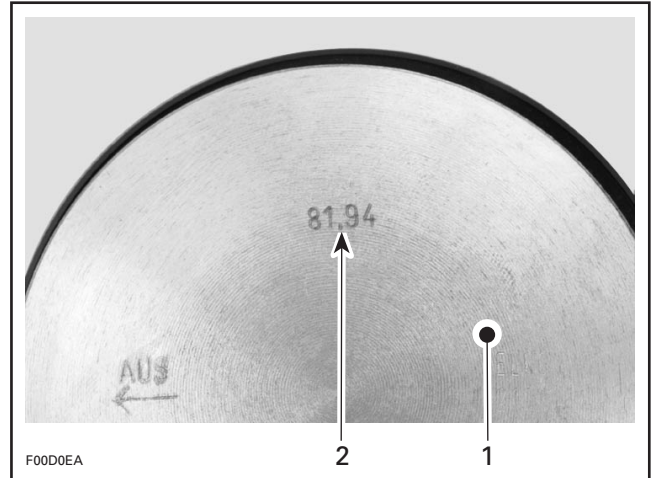

1. Piston dome
2. Piston measurement

Using a micrometer, measure piston skirt at 15 mm (.590 in) perpendicularly (90°) to piston pin.

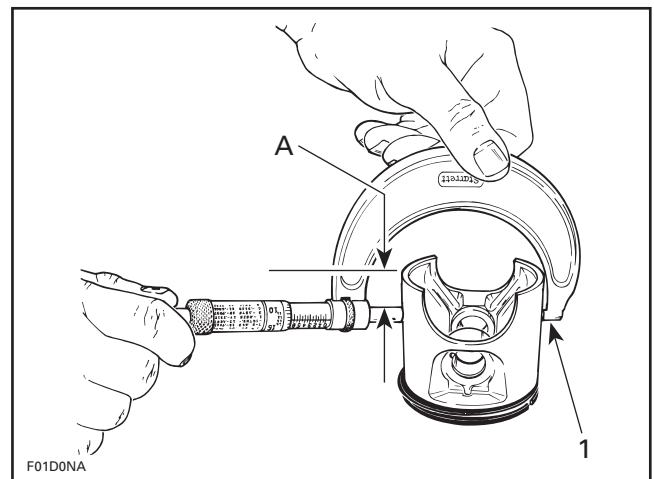

1. Measuring perpendicularly (90°) to piston pin axis
A. 15 mm (.590 in)

CYLINDER/PISTON CLEARANCE

Used and New Pistons

IMPORTANT: Make sure used piston is not worn more than specified. See USED PISTON MEASUREMENT above.

Take the measurement on the piston dome.

Section 03 ENGINES

Subsection 07 (ENGINE MEASUREMENT)

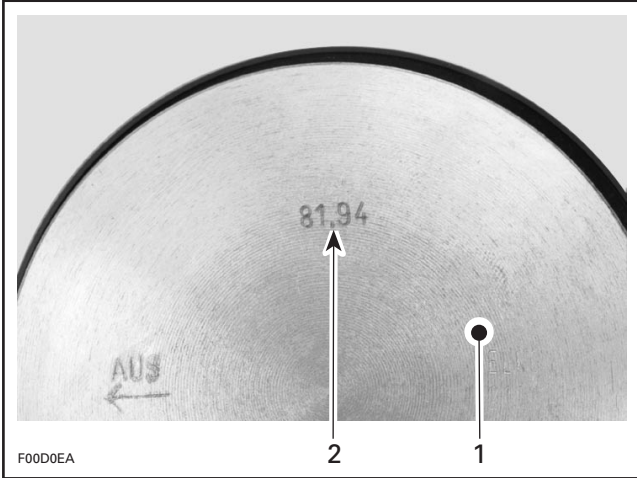

1. Piston dome
2. Piston measurement

Adjust and lock a micrometer to the specified value on the piston dome.

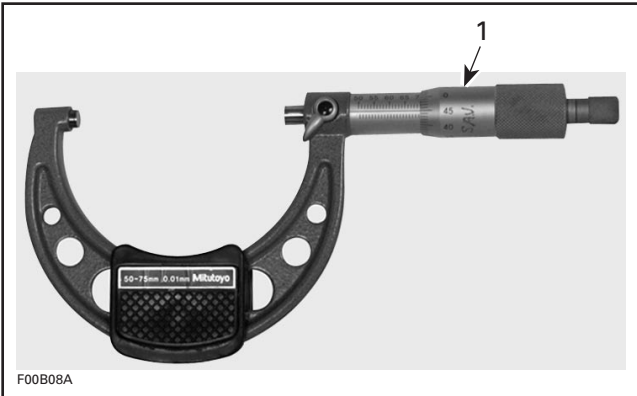

1. Micrometer set to the piston dimension

With the micrometer set to the piston dimension, adjust a cylinder bore gauge to the micrometer dimension and set the indicator to 0.

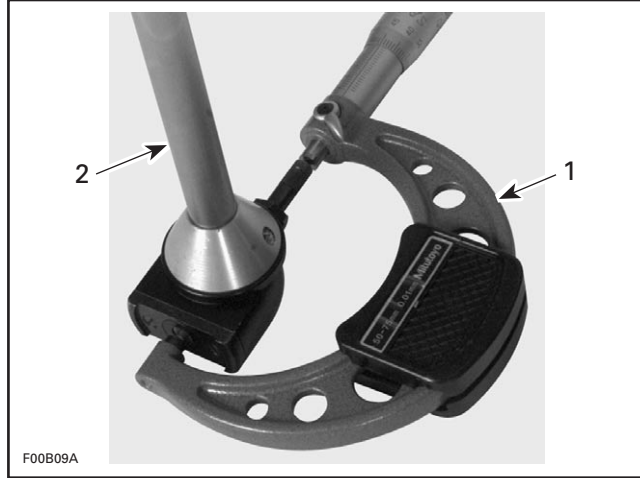

1. Use the micrometer to set the cylinder bore gauge
2. Dial bore gauge

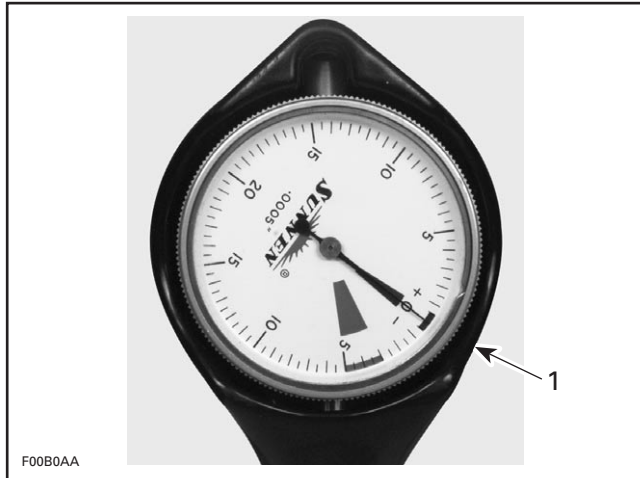

1. Indicator set to 0 (zero)

IMPORTANT: Always remove cylinders from crankcase before measuring.

Position the dial bore gauge at 16 mm (5/8 in) below cylinder top edge.

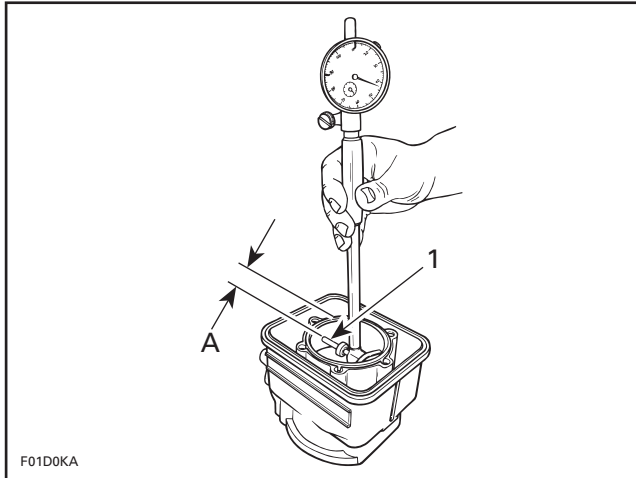

1. Measuring perpendicularly (90°) to piston pin axis
A. 16 mm (5/8 in)

Read the measurement on the cylinder bore gauge. The result is the exact piston/cylinder wall clearance. If clearance exceeds specified tolerance, replace cylinder or rebores and install oversize piston depending on engine.

NOTE: Make sure the cylinder bore gauge indicator is set exactly at the same position as with the micrometer, otherwise the reading will be false.

RING/PISTON GROOVE CLEARANCE

Using a feeler gauge check clearance between rectangular ring and groove. Replace piston if clearance exceeds specified tolerance.

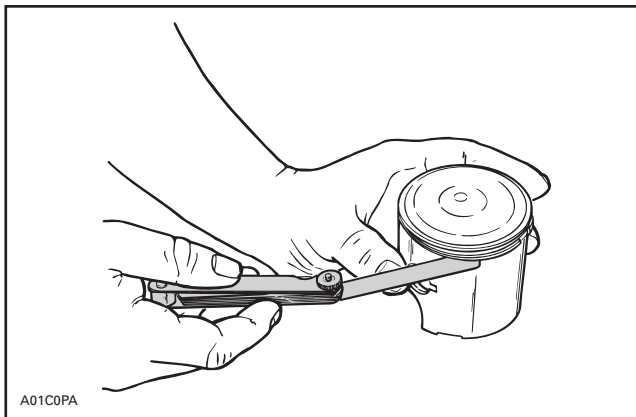

RING END GAP

Position ring half-way between transfer ports and intake port.

NOTE: In order to correctly position the ring in the cylinder, use piston as a pusher.

Using a feeler gauge, check ring end gap. Replace ring if gap exceeds specified tolerance.

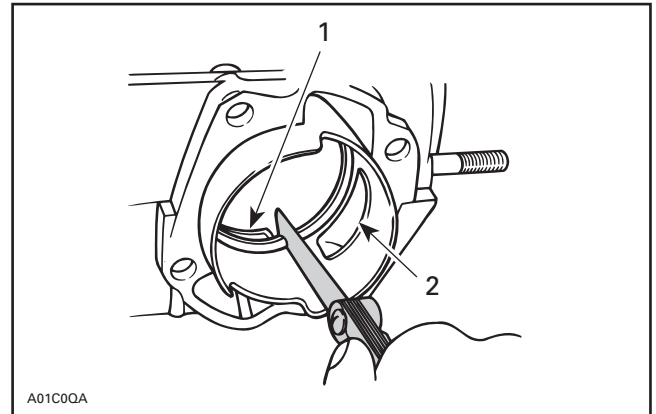

1. Transfer port
2. Intake port

CRANKSHAFT DEFLECTION

Crankshaft deflection is measured with a dial indicator.

Measuring (in crankcase)

First, check deflection with crankshaft in crankcase. If deflection exceeds the specified tolerance, recheck deflection using V-shaped blocks to determine the defective part(s). See below.

Measuring (on bench)

Once engine is disassembled, check crankshaft deflection on V-shaped blocks. If deflection exceeds the specified tolerance, it can be worn bearings or a bent crankshaft. Remove crankshaft bearings and check deflection again on V-shaped blocks to determine the defective part(s). See measurement A in following illustration.

Section 03 ENGINES

Subsection 07 (ENGINE MEASUREMENT)

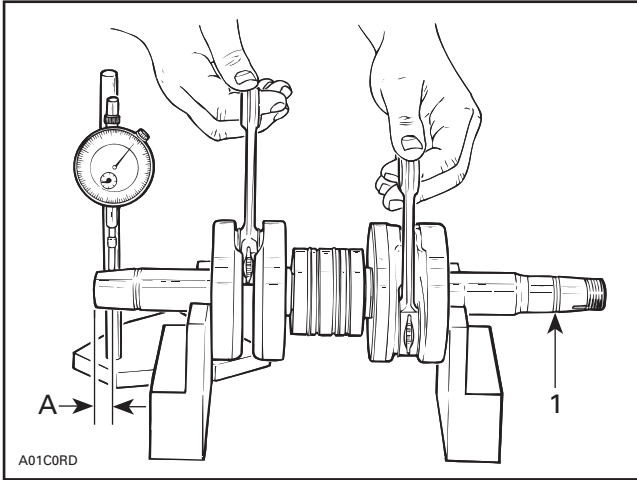

TYPICAL

1. Measure at mid point between the key and the first thread

A. 3 mm (1/8 in)

NOTE: Crankshaft deflection cannot be correctly measured between centers of a lathe.

If the deflection exceeds the specified tolerance, crankshaft should be repaired or replaced.

CONNECTING ROD BIG END AXIAL PLAY

Using a feeler gauge, measure distance between thrust washer and crankshaft counterweight. If the distance exceeds specified tolerance, repair or replace the crankshaft.

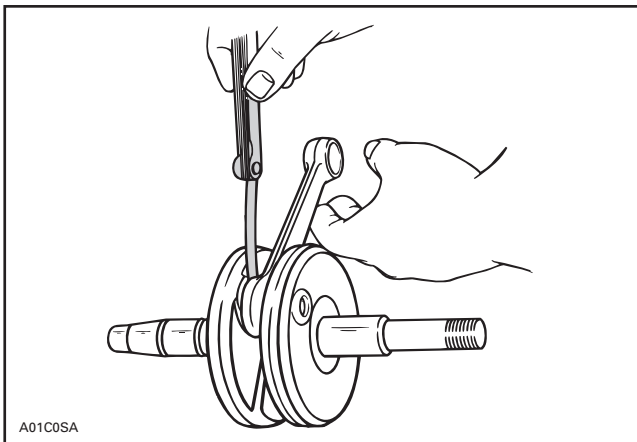

TYPICAL

CHECKING CRANKSHAFT ALIGNMENT

Install a degree wheel (P/N 529 035 607) on crankshaft end.

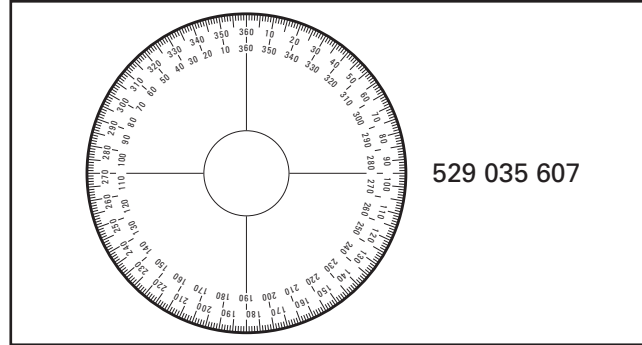

Remove both spark plugs.

Install a TDC gauge (P/N 414 104 700) in spark plug hole on MAG side.

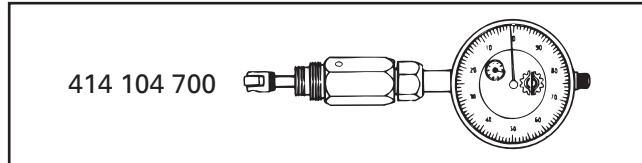

Bring MAG piston at top dead center.

Rotate degree wheel (not crankshaft) so that 360° mark aligns with center of crankcase. Scribe a mark on crankcase.

Remove TDC gauge and install it on center cylinder.

Bring PTO piston to top dead center. Degree wheel must rotate with crankshaft.

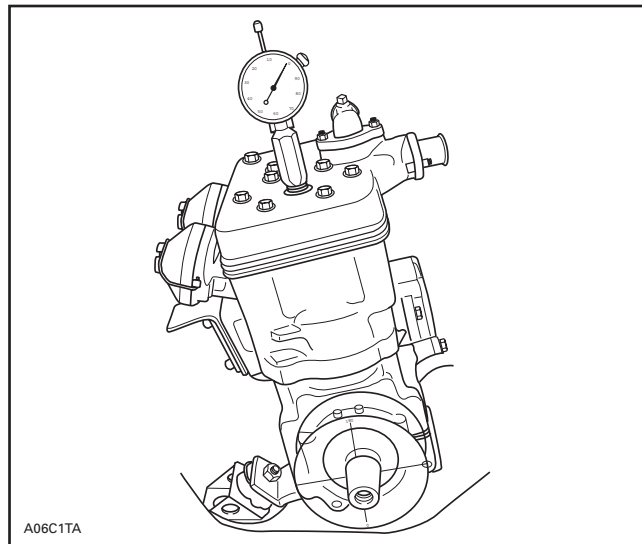

TYPICAL

Interval between cylinders must be $180^\circ \pm 0.5$.

Any other reading indicates a misaligned (twisted) crankshaft.

COOLING SYSTEM

SERVICE TOOLS

Description	Part Number	Page
engine leak tester kit	861 749 100	145
Holder wrench	420 876 357	138
Holder wrench	529 036 006	138
hose pincher.....	295 000 076	145
siphon tool.....	529 035 880	145
special radiator cap	529 021 400	145
Supertanium™ bit	529 031 800	145

SERVICE PRODUCTS

Description	Part Number	Page
Loctite 592.....	293 800 018	145
PREMIXED COOLANT	293 600 038	146

Section 03 ENGINES

Subsection 08 (COOLING SYSTEM)

Axial Fan Cooling System

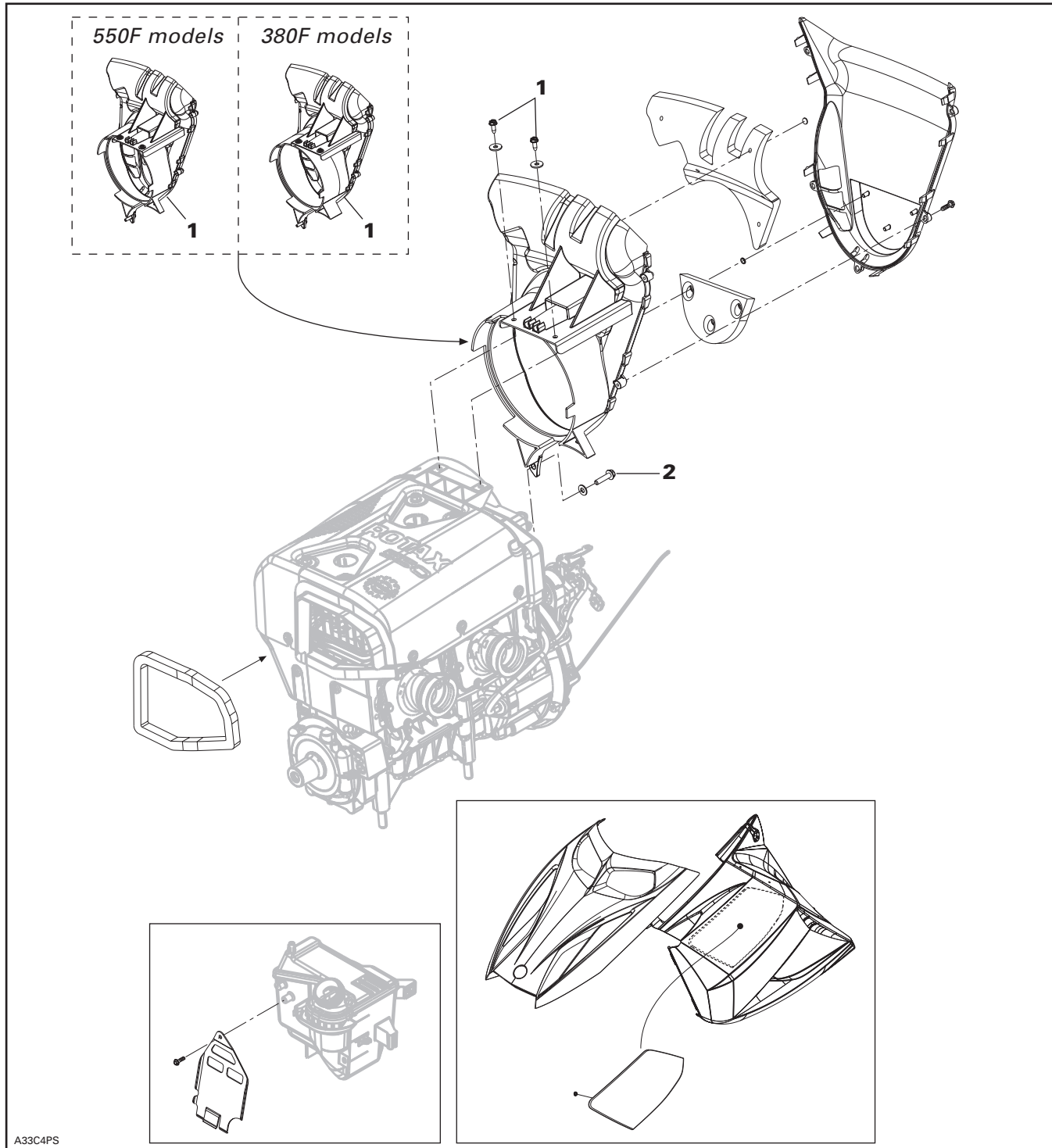

A33C4PS

Section 03 ENGINES
Subsection 08 (COOLING SYSTEM)

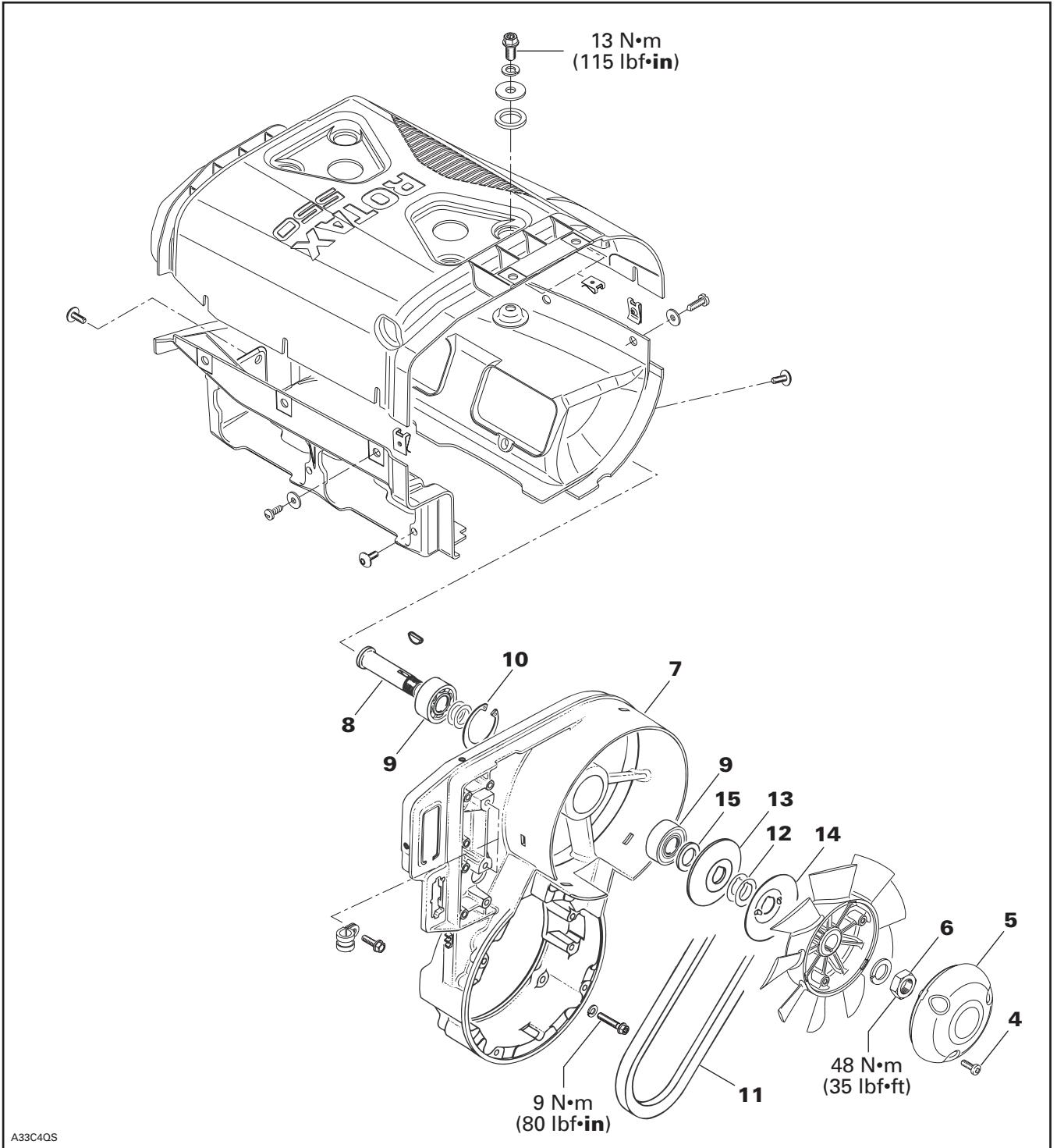

Section 03 ENGINES

Subsection 08 (COOLING SYSTEM)

COOLING FAN REMOVAL AND INSTALLATION

Remove the tuned pipe to gain access. Refer to EXHAUST SYSTEM.

Unscrew the 2 screws **no. 1** and **no. 2** of inlet duct **no. 3**. Remove the inlet duct by unclipping the tabs using a flat screwdriver from the engine fan housing.

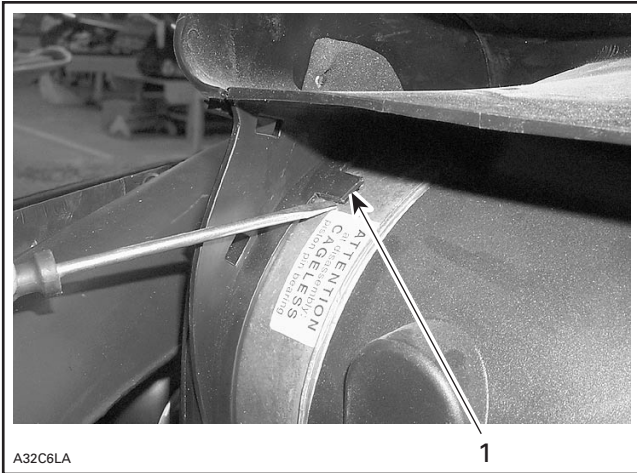

A32C6LA

TYPICAL

1. Tab

Unscrew the screws **no. 4** to remove the fan cover **no. 5**.

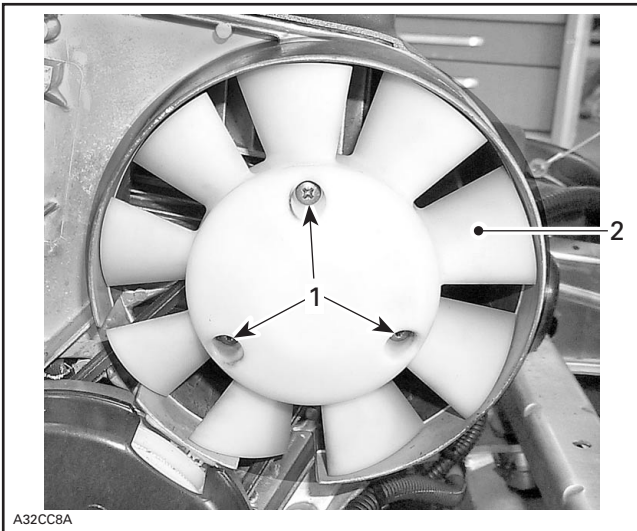

A32CC8A

1. Screws
2. Cover

To remove or install fan pulley retaining nut **no. 6**, lock fan pulley with special holder wrench and 3 screws as per following table:

ENGINE	TOOL
377	Holder wrench (P/N 420 876 357)
552	Holder wrench (P/N 529 036 006)

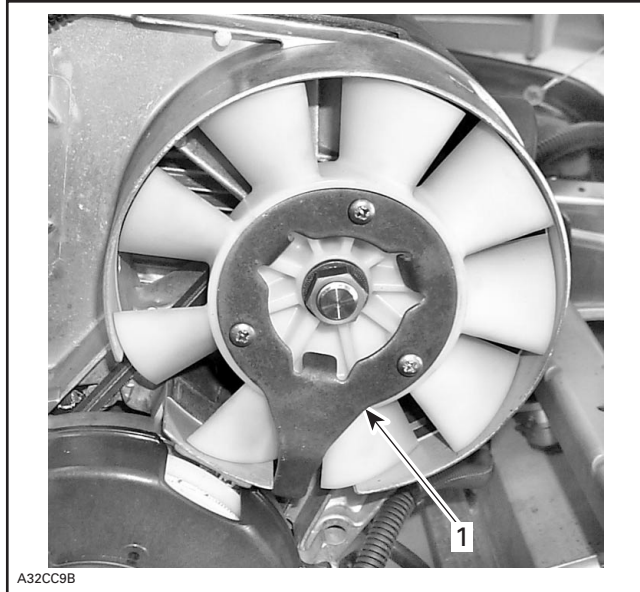

A32CC9B

1. Holder wrench

At assembly, torque nut **no. 6** to 48 N•m (35 lbf•ft).



A32CCA

TYPICAL

COOLING FAN BEARING REPLACEMENT

Remove cooling fan as explained in this section.

Remove support fan housing **no. 7**. Refer to TOP END and MAGNETO SYSTEM.

Using a press, drive the fan shaft **no. 8** out.

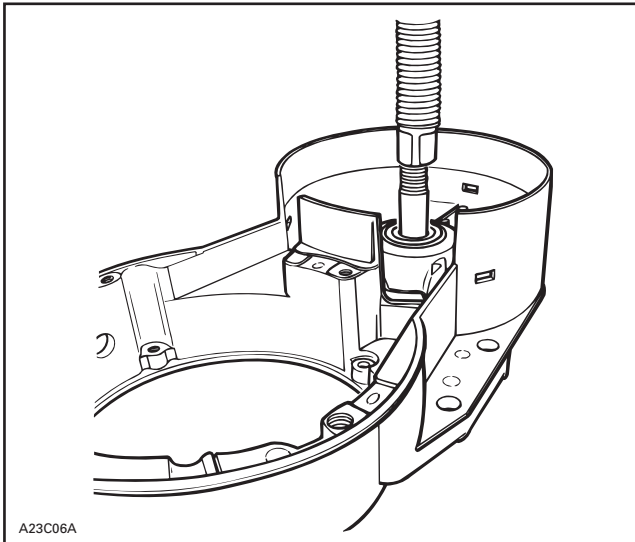

Support fan housing **no. 7** with a ring. With a punch, working all around bearing **no. 9** inner race, drive bearing out of fan housing. Keep shims for installation.

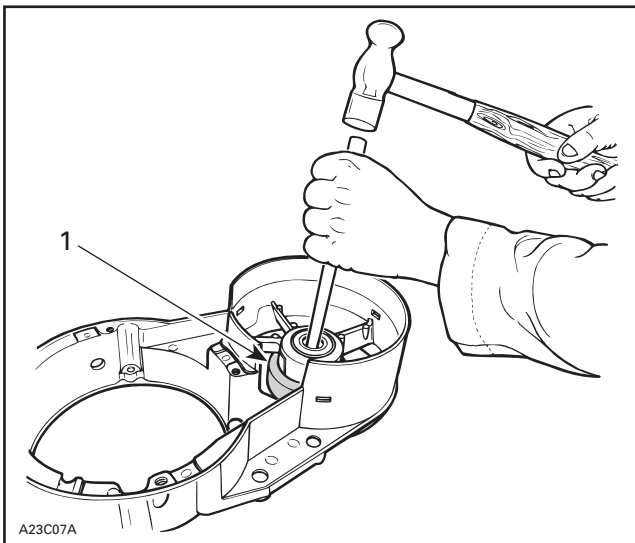

1. Ring supporting fan housing

Remove circlip **no. 10** then remaining bearing.

To install, press one bearing in place then install circlip and shims. Press the other bearing from opposite side until it is flush with housing. Press fan shaft from engine side of fan housing. Check for free rolling action.

FAN BELT REPLACEMENT AND DEFLECTION ADJUSTMENT

Remove tuned pipe and muffler. Refer to EX-HAUST SYSTEM.

Remove rewind starter and oil pump with gear case. Refer to REWIND STARTER.

Remove cooling fan as explained in this section.

Remove pulley half.

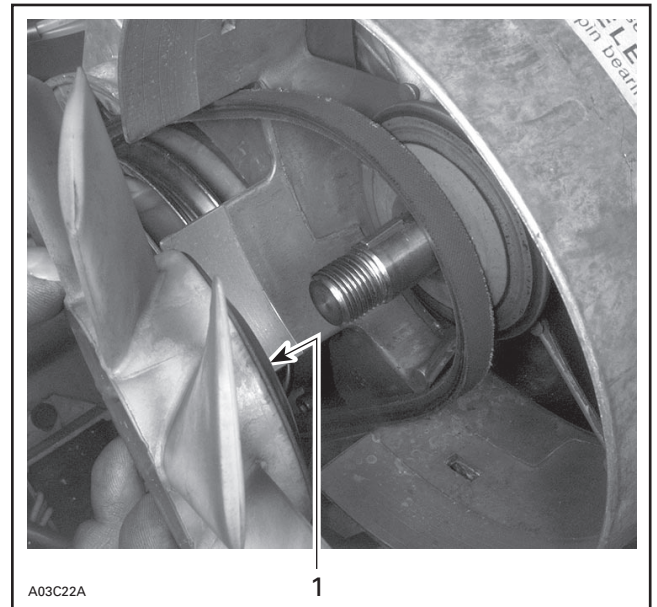

1. Fan with pulley half

Remove fan belt **no. 11**.

Leave shims and second half pulley in place. Refer to the following photo.

Section 03 ENGINES

Subsection 08 (COOLING SYSTEM)

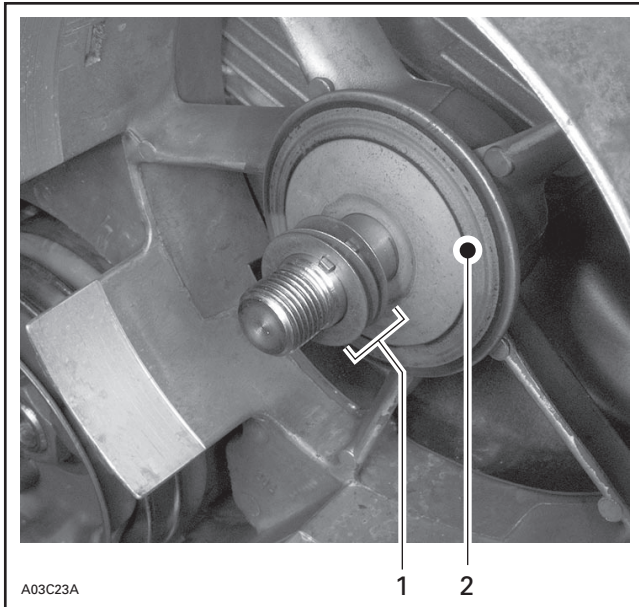

A03C23A

1. Keep shims
2. Leave second half pulley in place

Install new fan belt on bottom pulley first then position onto fan shaft, as shown in the next photo.

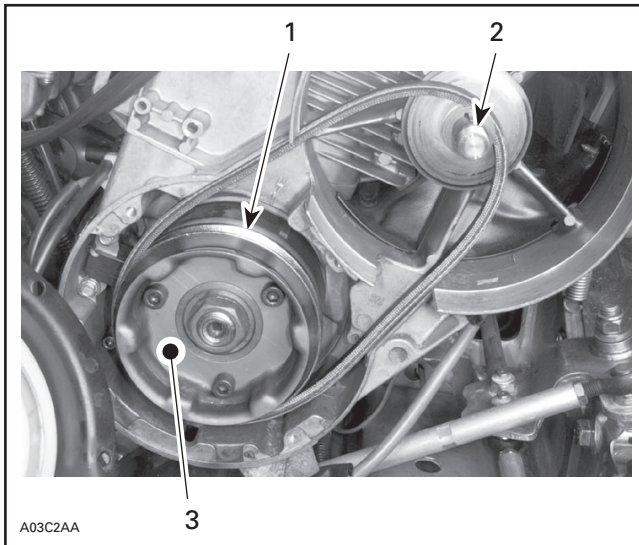

A03C2AA

FAN BELT PROPERLY INSTALLED ON BOTTOM PULLEY AND FAN SHAFT

1. Bottom pulley
2. Fan shaft
3. Starting pulley

Reinstall fan assembly on fan shaft. Temporarily tighten fan nut.

CAUTION: When reinstalling fan assembly, ensure that key is properly positioned into fan shaft keyway.

Fan Belt Deflection Adjustment

Check fan belt deflection using a ruler and a fish scale positioned midway between pulleys as per following photo.

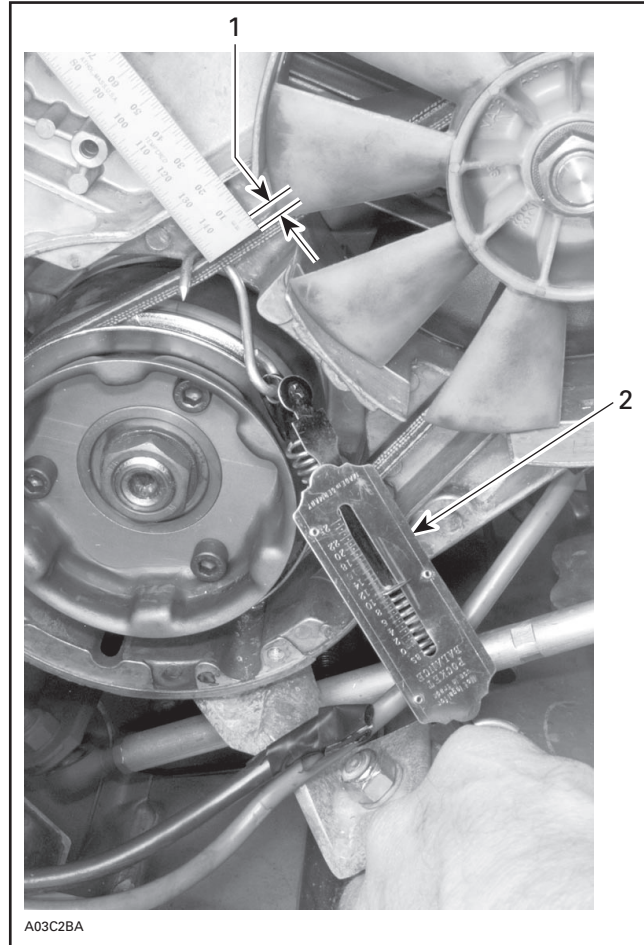

A03C2BA

TYPICAL

1. Measure deflection here
2. Fish scale

Belt deflection must be according to the following specifications:

ENGINE	BELT DEFLECTION	FORCE APPLIED
377 and 552	9.5 mm (3/8 in)	5 kg (11 lb)

To adjust deflection tension, add or remove shim(s) no. 12 between pulley halves no. 13 and no. 14. Install excess shim(s) between distance sleeve no. 15 and pulley half no. 13 (housing side).

Section 03 ENGINES
Subsection 08 (COOLING SYSTEM)

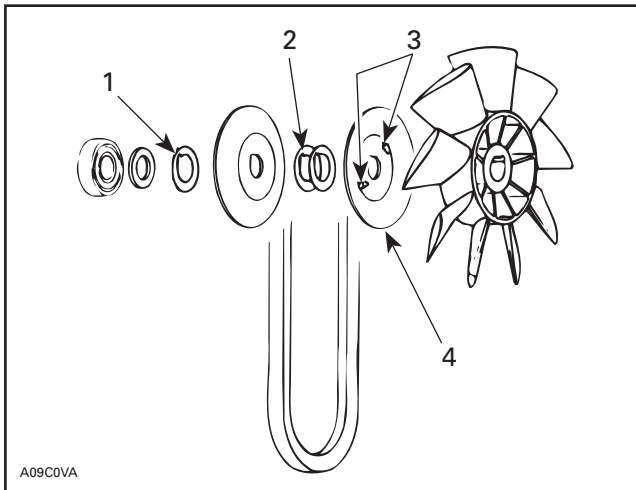

TYPICAL

1. Unused shim(s) here
2. Adjust here
3. Positioning noses
4. Some engines only

Select pulley halves so that the one with 2 positioning noses will be on fan side. Ensure to insert these noses into fan notches.

Once fan belt is properly adjusted, torque fan nut to 48 N•m (35 lbf•ft) using holder wrench, as shown in the following photo.



TYPICAL — TORQUE FAN NUT USING HOLDER WRENCH

Finalizing Reassembly

Reinstall rewind starter and oil pump with gear case. Refer to REWIND STARTER.

Section 03 ENGINES
Subsection 08 (COOLING SYSTEM)

LIQUID COOLING SYSTEM

Carbureted Models except Summit

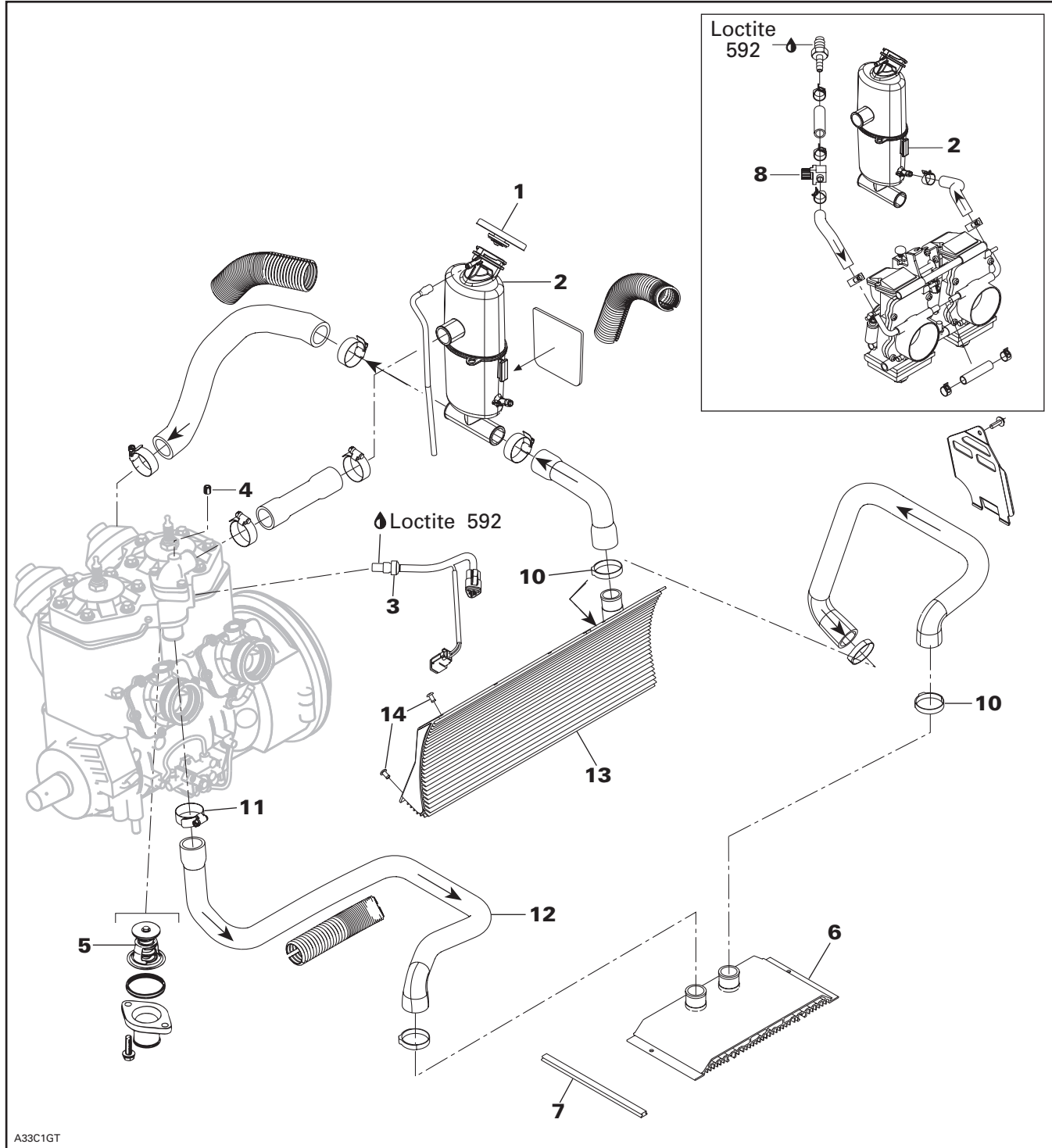

A33C1GT

Section 03 ENGINES
Subsection 08 (COOLING SYSTEM)

SDI Models

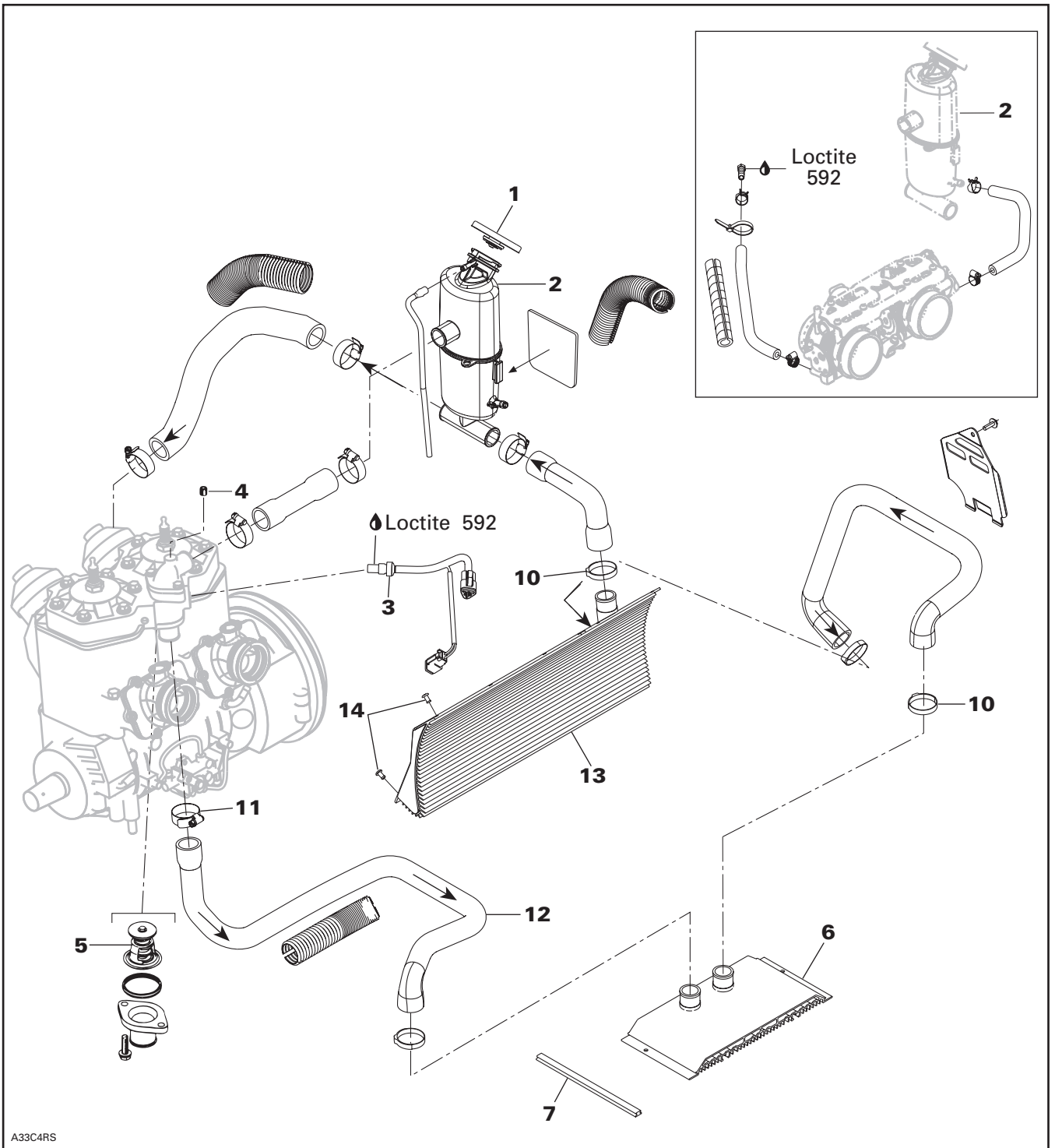

A33C4RS

Section 03 ENGINES
Subsection 08 (COOLING SYSTEM)

Summit Models

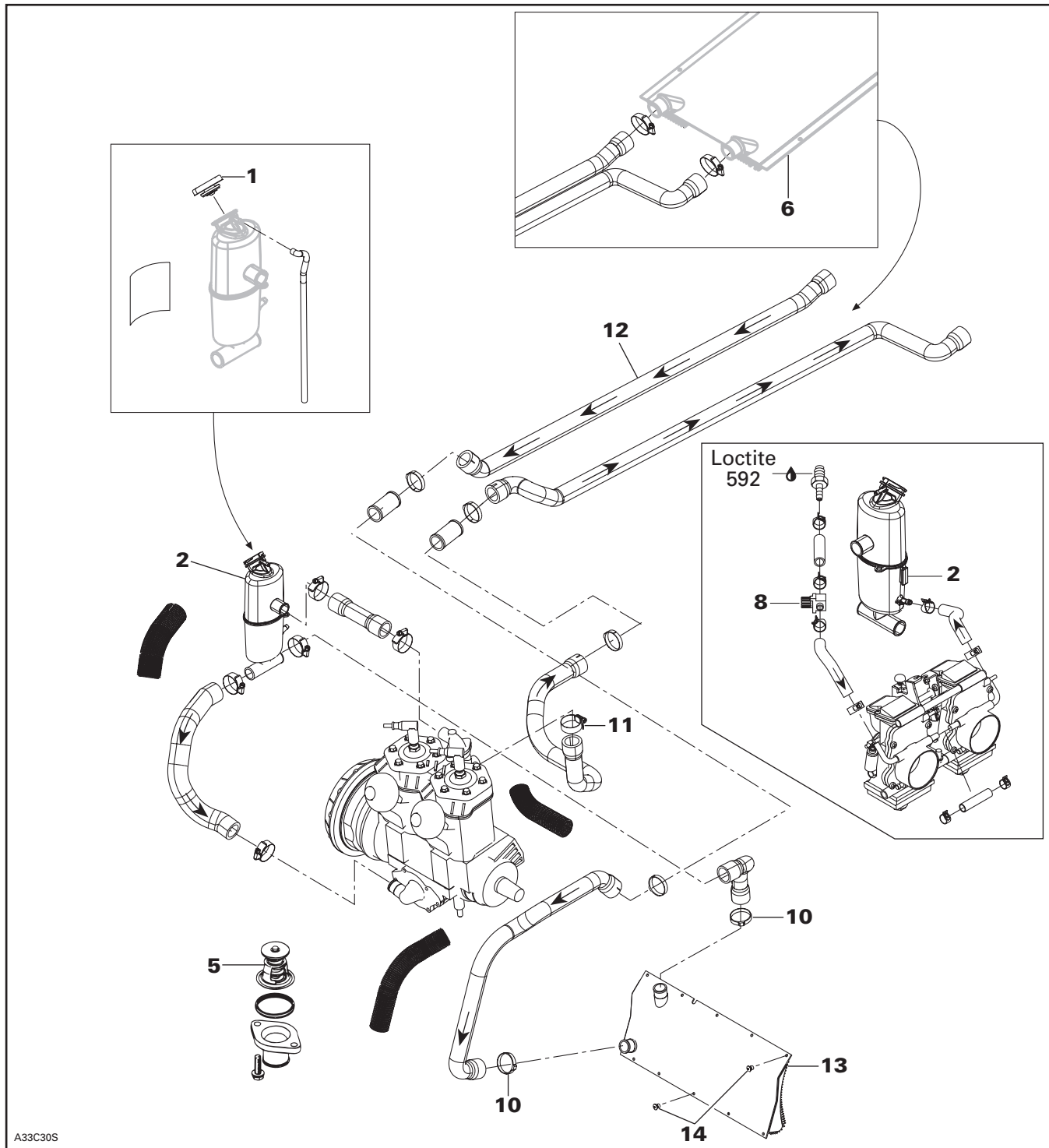

A33C30S

COOLING SYSTEM LEAK TEST

⚠ WARNING

To prevent burning yourself, do not remove the radiator cap if the engine is hot.

Install special radiator cap (P/N 529 021 400) included in the engine leak tester kit (P/N 861 749 100) on coolant tank. Install hose pincher (P/N 295 000 076) on overflow hose. Using pump also included in kit pressurize all system through coolant reservoir to 100 kPa (15 PSI).

Check all hoses and cylinder/base for coolant leaks. Spray a soap/water solution and look for air bubbles.

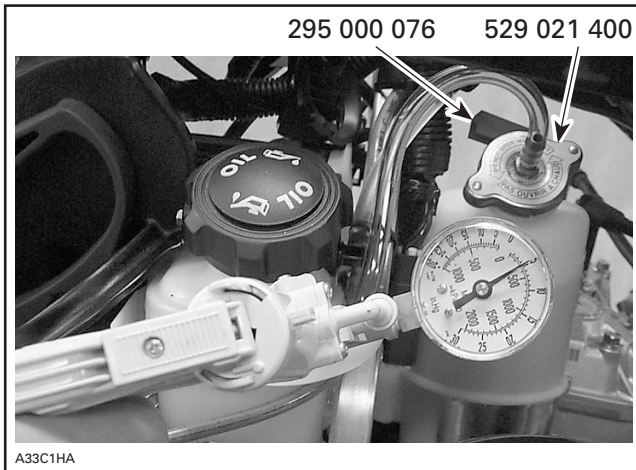

INSPECTION

Check general condition of hoses and clamp tightness.

DRAINING THE SYSTEM

⚠ WARNING

Never drain or refill the cooling system when engine is hot.

To drain the cooling system, siphon the coolant mixture from the coolant tank **no. 2** using the siphon tool (P/N 529 035 880). Disconnect hose at water pump to drain coolant from engine.

When the coolant level is low enough, lift the rear of vehicle to drain the radiator.

DISASSEMBLY AND ASSEMBLY

Coolant Pump

Refer to BOTTOM END section.

Sender and Plug

Apply Loctite 592 (P/N 293 800 018) thread sealant on sender **no. 3** and plug **no. 4** to avoid leaks.

Pressure Cap

Check if the cap **no. 1** pressurizes the system for 3 minutes. If not, install a new 90 kPa (13 PSI) cap (do not exceed this pressure).

Coolant Tank

For removal, drain cooling system before removing coolant tank **no. 2**.

Remove all hoses from coolant tank.

Remove injection oil reservoir retaining screws to slide down the coolant tank to disengage it from oil tank.

NOTE: It is necessary to move oil tank for an easier removal/installation of coolant tank.

Check if the tank is cracked or melted. Replace if necessary.

For installation, reverse the removal procedure.

Front Radiator

Remove all debris between radiator fins. A clean radiator is more efficient than a dirty one.

Check if the radiator fins are damaged. Replace the front radiator **no. 13** if necessary.

NOTE: A radiator with many broken fins does not work properly.

For disassembly, drain cooling system.

Remove rear suspension (refer to REAR SUSPENSION).

Using Supertanium™ bit (P/N 529 031 800), drill all rivets **no. 14** retaining front radiator to the frame or grind the rivets with a grinding disk.

Pull the radiator a little and remove the Oetiker clamps **no. 10**.

For installation, reverse the removal procedure.

Section 03 ENGINES

Subsection 08 (COOLING SYSTEM)

Rear Radiator and Rear Radiator Protector

Refer to FRAME for rear radiator removal/installation procedures.

For cleaning and inspection refer to FRONT RADIATOR.

Radiator and Radiator Protector

Insert radiator protector no. 7 into radiator C-rail and crimp C-rail at rear end. Refer to FRAME for radiator no. 6 removal.

Thermostat

For disassembly of thermostat no. 5, drain the cooling system (see above).

Unscrew clamp no. 11 retaining hose no. 12 to the water outlet socket.

Remove:

- water outlet
- socket screws
- gasket thermostat.

To check thermostat, put in water and heat water. Thermostat should start to open when water temperature reaches the following degree.

To check thermostat, put in water and heat water. Thermostat should start to open when water temperature reaches the following degree.

ENGINE	TEMPERATURE
All	42°C (108°F)

It will be almost fully open at 50°C (122°F).

For installation, reverse the removal procedure.

COOLING SYSTEM REFILLING PROCEDURE

CAUTION: To prevent rust formation or freezing condition, always replenish the system with the BRP premixed coolant or with 50% antifreeze and 50% water. Pure antifreeze without water freezes (like slush ice). Always use ethylene glycol antifreeze containing corrosion inhibitors specifically recommended for aluminum engines.

System Capacity

Refer to TECHNICAL DATA.

Refilling Procedure

IMPORTANT: USE THE PREMIXED COOLANT (P/N 293 600 038). Do not reinstall pressure cap.

With engine cold, refill coolant tank up to COLD LEVEL line. Start engine. Refill up to line while engine is idling until rear radiators are warm to the touch (about 4 to 5 minutes). Always monitor coolant level while filling tank to avoid emptying. Install pressure cap.

Lift rear of vehicle and support it safely.

Activate throttle lever 3 - 4 times to bring engine speed to 7000 RPM.

Apply the brake.

Lower vehicle back on ground and add coolant up to 15 mm (1/2 in) above the COLD LEVEL line.

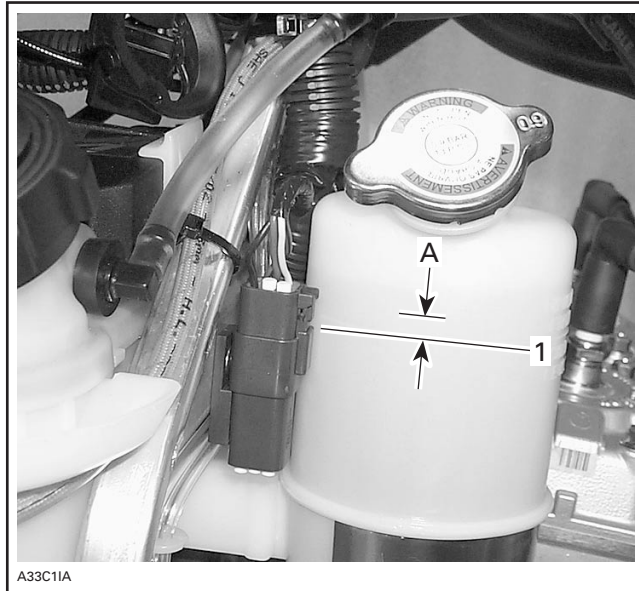

1. Cold level line

A. 15 mm (1/2 in)

Lift front of vehicle of 60 cm (24 in) and support it safely. Let the vehicle idle for two minutes.

Put vehicle back on ground and add coolant up to 15 mm (1/2 in) over COLD LEVEL line.

When engine has completely cooled down, recheck coolant level in coolant tank and refill up to line if needed.

Check for coolant mixture freezing point. Specification is - 37°C (- 35°F). Adjust as necessary.

REWIND STARTER

SERVICE PRODUCTS

<u>Description</u>	<u>Part Number</u>	<u>Page</u>
Molykote PG 54.....	420 899 763	151, 153

Section 03 ENGINES

Subsection 09 (REWIND STARTER)

Rewind Starter on Fan Cooled Models

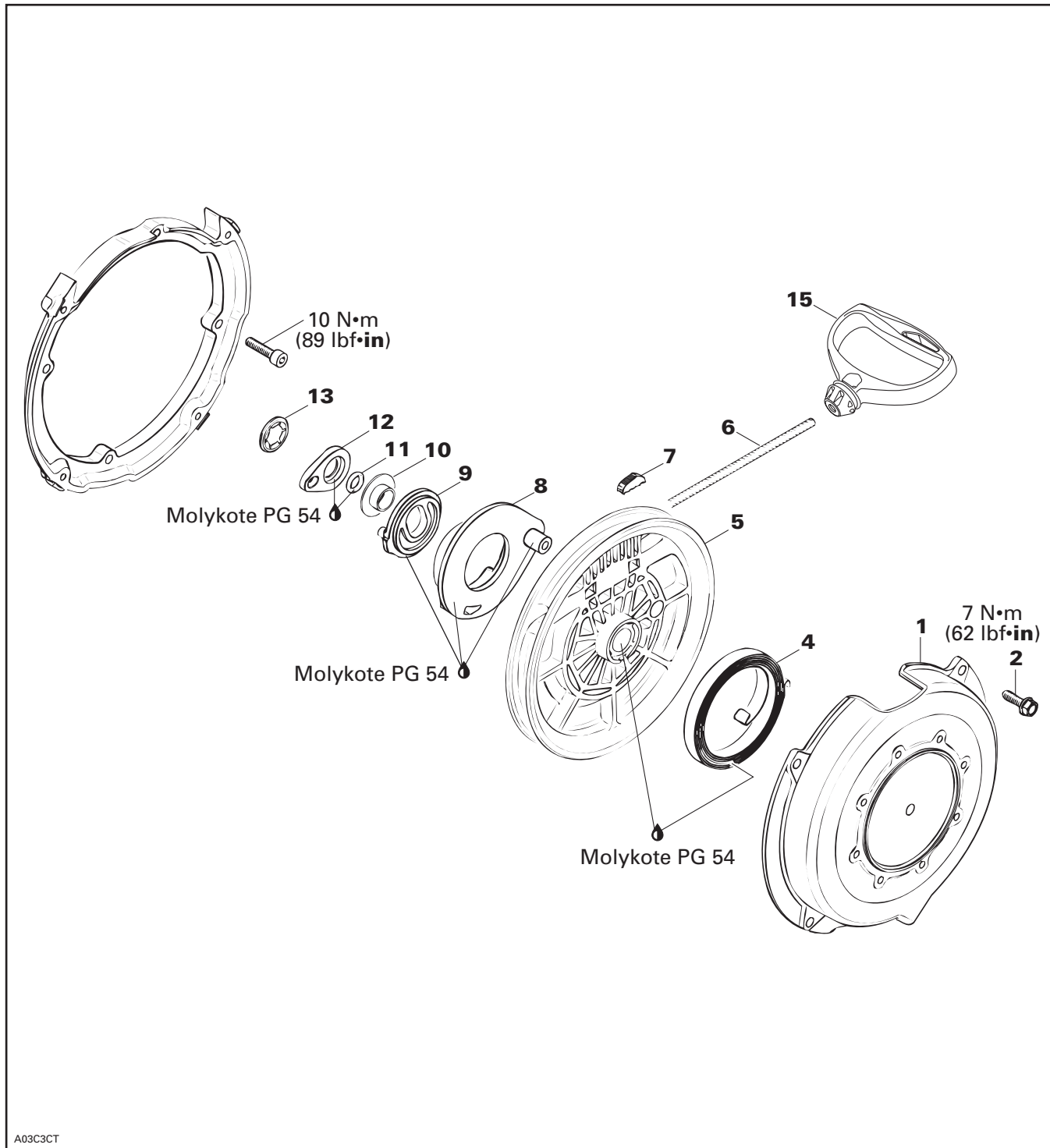

TYPICAL

Rewind Starter on Liquid Cooled Models

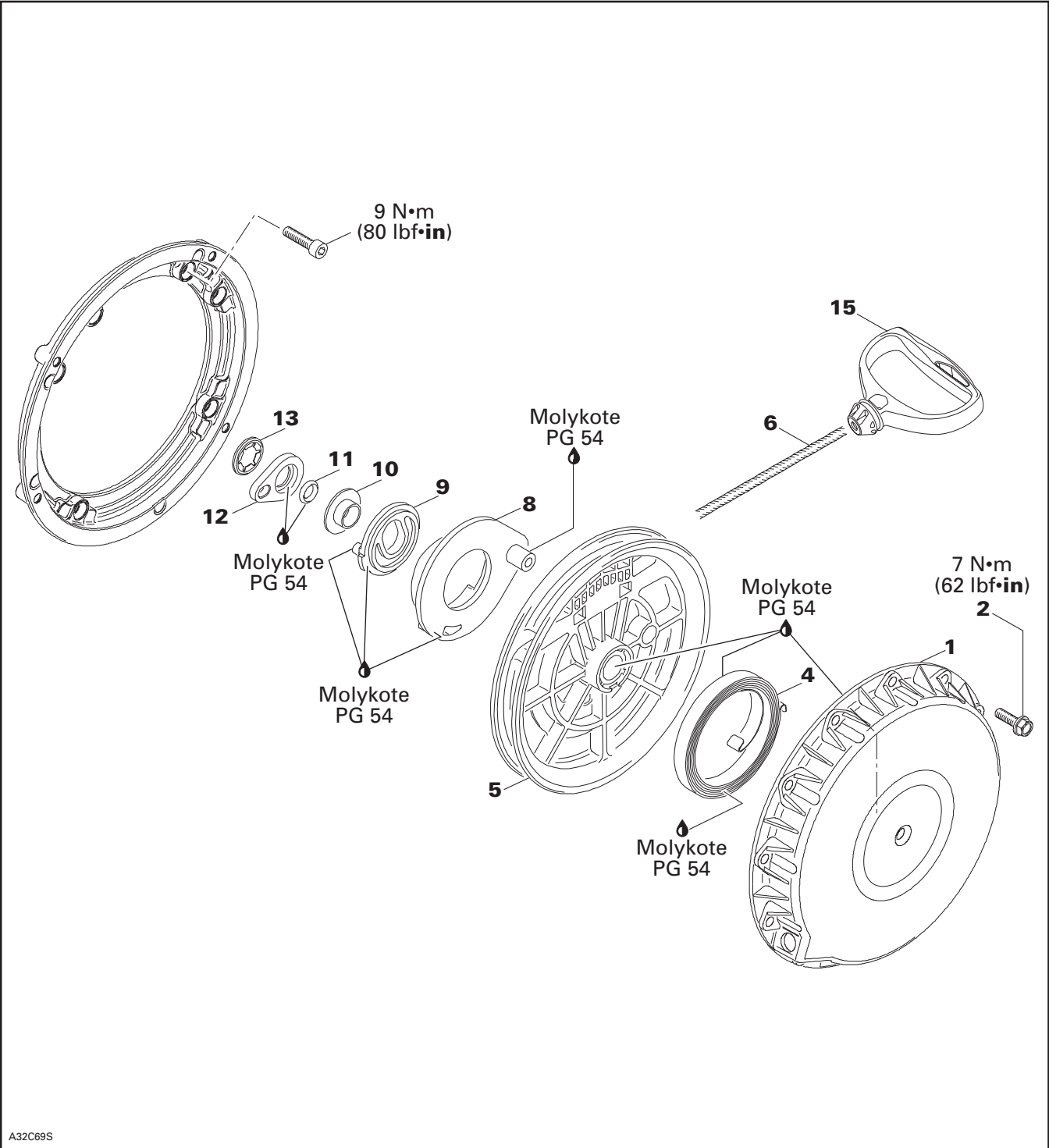

Section 03 ENGINES

Subsection 09 (REWIND STARTER)

INSPECTION

NOTE: Due to dust accumulation, rewind starter must be periodically cleaned, inspected and relubricated.

CAUTION: It is of the utmost importance that the rewind starter spring be lubricated periodically using specific lubricant. Otherwise, rewind starter component life will be shortened and/or rewind starter will not operate properly under very cold temperatures.

Check if rope no. 6 is fraying, replace if so.

When pulling starter grip, mechanism must engage within 30 cm (1 ft) of rope pulled. If not, disassemble rewind starter, clean and check for damaged plastic parts. Replace as required, lubricate, reassemble and recheck. Always replace O-ring no. 11 every time rewind starter is disassemble.

When releasing starter grip, it must return to its stopper and stay against it. If not, check for proper spring preload or damages. Readjust or replace as required.

When pulling starter grip 10 times in a row, it must return freely. If not, check for damaged parts or lack of lubrication. Replace parts or lubricate accordingly.

REMOVAL

Using a small screwdriver, extract rope knot from starter grip no. 15. Cut rope close to knot. Tie a knot near starter.

Remove screws no. 2 securing rewind starter no. 1 to engine then remove rewind starter.

Fan Cooled Models Only

Remove pump from rewind starter cover.

ROPE REPLACEMENT

Fan Cooled Models Only

Completely pull out rope. Hold rewind starter in a vise.

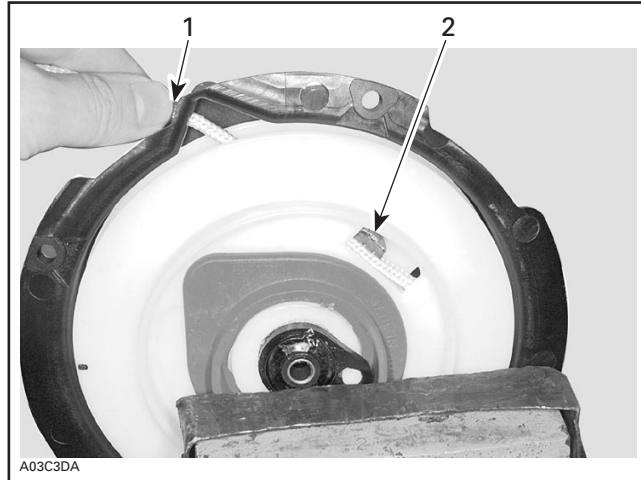

1. Rope exit hole
2. Key to be removed

With a long thin pin punch inserted through rope exit hole, push key no. 7. Remove key and rope. Install a new rope and lock it using key no. 7.

NOTE: When rope is completely pulled out, spring preload is 4-1/2 turns.

Liquid Cooled Models Only

Pull out rope. Hold rewind starter in a vise. Slide rope and untie the knot. Pull out the rope completely.

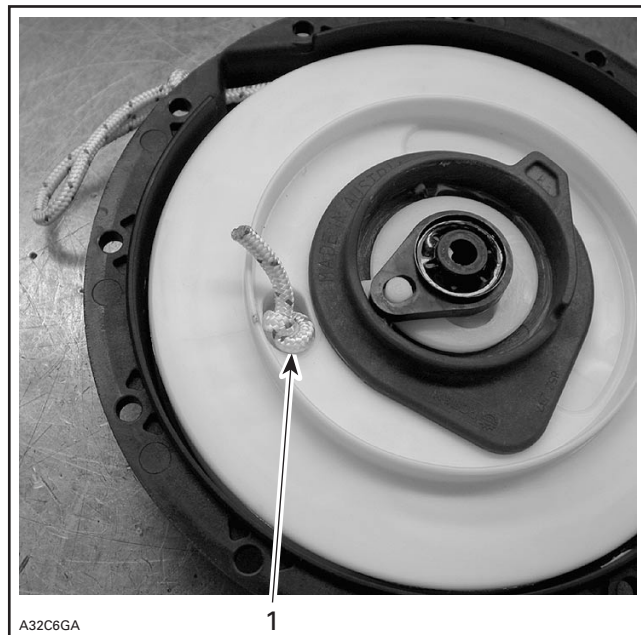

1. Knot to be untied

NOTE: When rope is completely pulled out, spring preload is 4-1/2 turns.

DISASSEMBLY

Undo knot previously tied at removal. Let sheave get free to release spring preload.

Cut push nut no. 13 and discard. Remove locking element no. 12, O-ring no. 11, step collar no. 10, pawl lock no. 9 and pawl no. 8.

Remove sheave no. 5 from starter housing no. 1. Hold spring with a screwdriver.

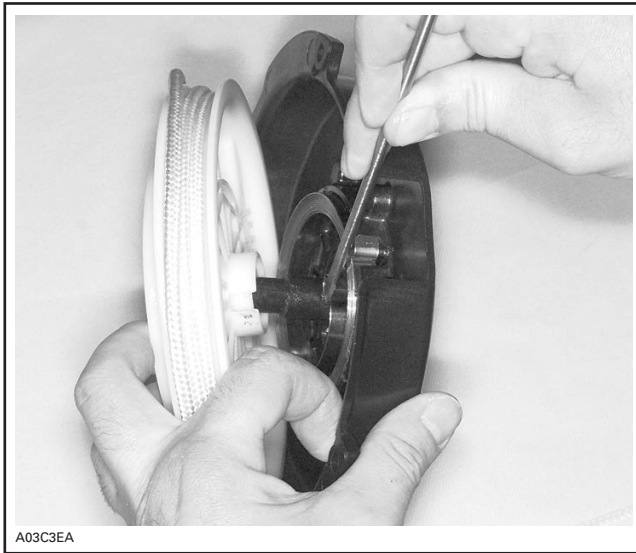

Fan Cooled Models Only

Disengage key no. 7 and pull out rope no. 6.

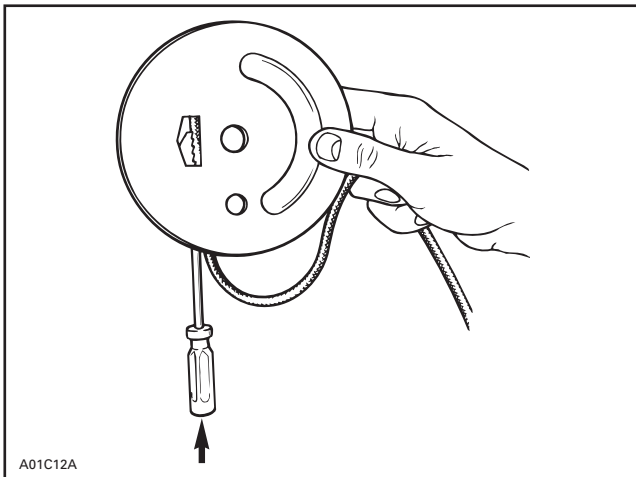

GENTLY TAP ON KEY

Liquid Cooled Models Only

Take out the knot and then rope no. 6.

ASSEMBLY

At assembly, position spring no. 4 outer end into spring guide notch then wind the spring counter-clockwise into guide.

⚠ WARNING

Since the spring is tightly wound inside the guide it may fly out when rewind is handled. Always handle with care.

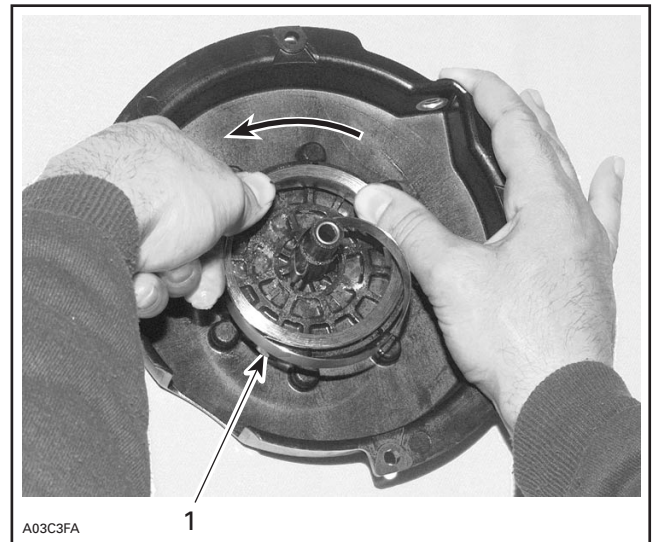

1. Outer end into guide notch

CAUTION: It is of the utmost importance that the rewind starter spring be lubricated periodically using Molykote PG 54 (P/N 420 899 763). Otherwise, rewind starter component life will be shortened and/or rewind starter will not operate properly under very cold temperatures.

Lubricate spring assembly and 1 cm (1/2 in) wide on bottom of housing with Molykote PG 54 (P/N 420 899 763).

Section 03 ENGINES

Subsection 09 (REWIND STARTER)

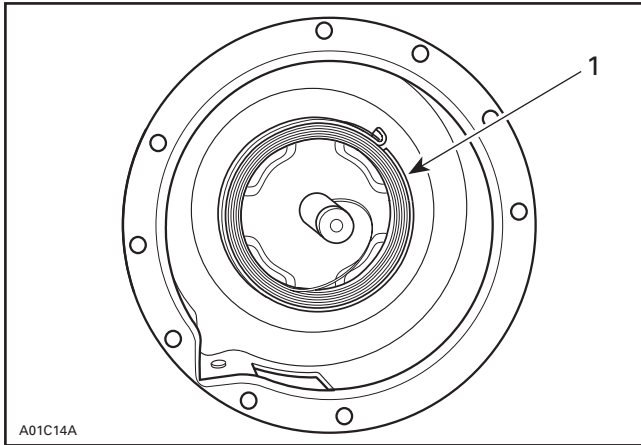

A01C14A

TYPICAL
1. Molykote PG 54 inside spring guide

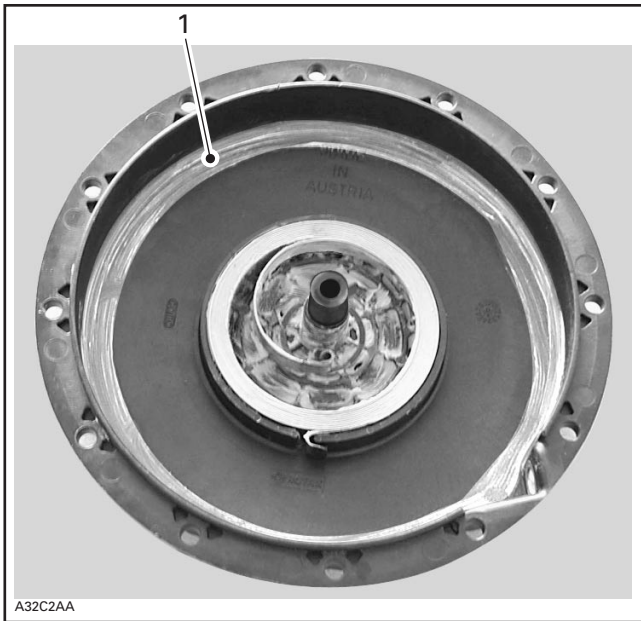

A32C2AA

1. Molykote PG 54 applied 1 cm (1/2 in) wide on bottom of housing

CAUTION: The use of standard multipurpose grease could result in rewind starter malfunction.

Fan Cooled Models Only

To install rope no. 6, insert rope into sheave no. 5 orifice and lock it with the key no. 7 as illustrated.

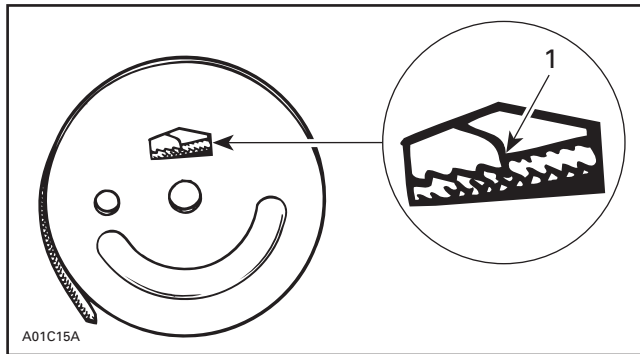

A01C15A

1. Push to lock

Lubricate housing post with silicone compound grease. Install sheave.

Liquid Cooled Models Only

To install rope no. 6, insert rope into sheave no. 5 orifice and lock it by making a knot, leaving behind a free portion of about 25 mm in length. Fuse rope end with a lit match and insert it into sheave.



A32C6HA

FREE PORTION

Section 03 ENGINES
Subsection 09 (REWIND STARTER)



FREE PORTION INSERTED INTO SHEAVE

Lubricate housing post with silicone compound grease. Install sheave.

To adjust rope tension:

Wind rope on sheave and place rope sheave into starter housing making sure that the sheave hub notch engages in the rewind spring hook.

Rotate the sheave counterclockwise until rope end is accessible through rope exit hole. This will give 1/2 turn of preload.

Pull the rope out of the starter housing and temporarily make a knot to hold it.

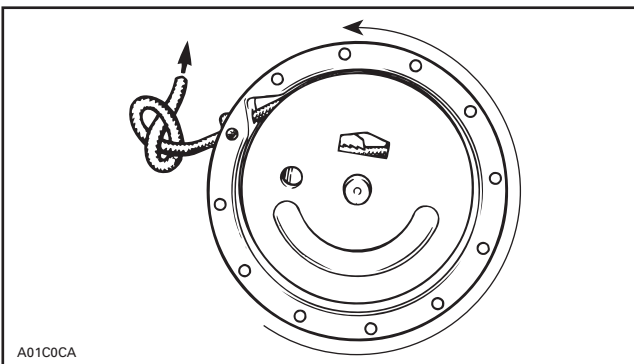

TYPICAL

Lubricate pawl **no. 8** with Molykote PG 54 (P/N 420 899 763) then install over rope sheave.



Lubricate pawl lock **no. 9** with Molykote PG 54 (P/N 420 899 763). Install over pawl.



Install step collar **no. 10** with its sleeve first. Lubricate a new O-ring **no. 11** and locking element **no. 9** with Molykote PG 54 (P/N 420 899 763). Install over pawl lock.

Section 03 ENGINES

Subsection 09 (REWIND STARTER)

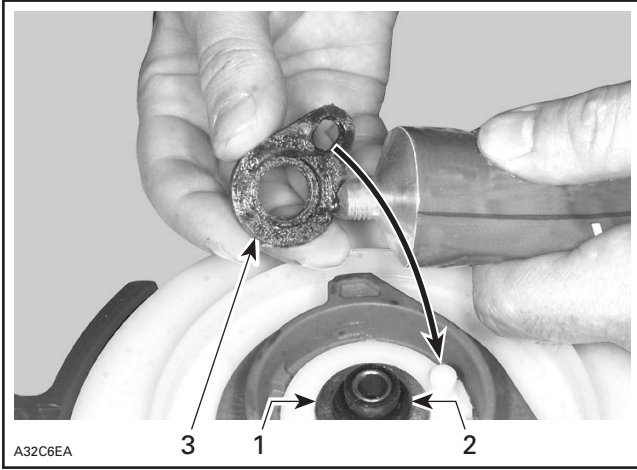

1. Step collar
2. O-ring
3. Locking element

Position a new push nut no. 13.

INSTALLATION

Thread starter rope no. 6 through rope guide when applicable.

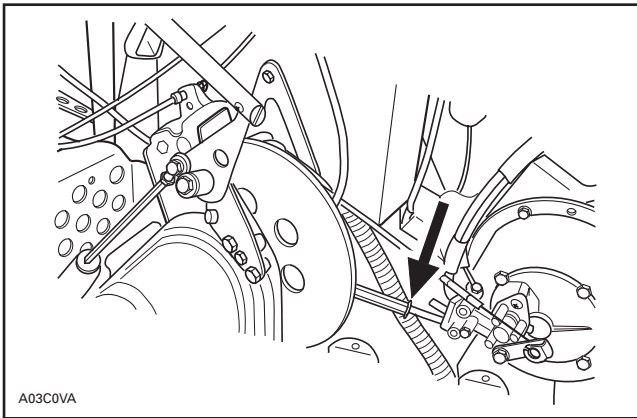

TYPICAL

Reinstall rewind starter assembly on engine.

Prior to installing starter grip no. 15 on new rope, it is first necessary to fuse the rope end with a lit match. Pass rope through starter grip and tie a knot in the rope end. Fuse the knot with a lit match then insert rope end down and pull the starter grip over the knot.

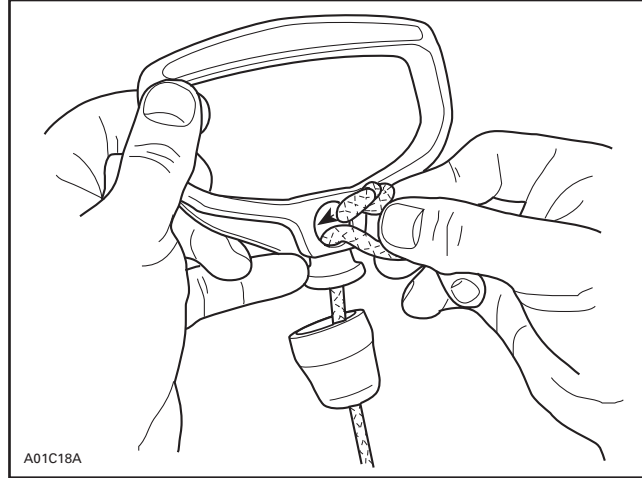

TYPICAL

Fan Cooled Models Only

Reinstall oil pump with gear case (552 engine). Refer to LUBRICATION SYSTEM.

OIL INJECTION SYSTEM

SERVICE TOOLS

Description	Part Number	Page
gear holder.....	420 876 695	161
hose pincher.....	295 000 076	158, 160
leak testing kit	529 033 100	158
small hose pincher.....	295 000 076	158

SERVICE PRODUCTS

Description	Part Number	Page
Loctite 648 (green)	413 711 400	161
Molykote 111.....	413 707 000	161
pulley flange cleaner.....	413 711 809	161

Section 03 ENGINES

Subsection 10 (OIL INJECTION SYSTEM)

Fan-cooled Models

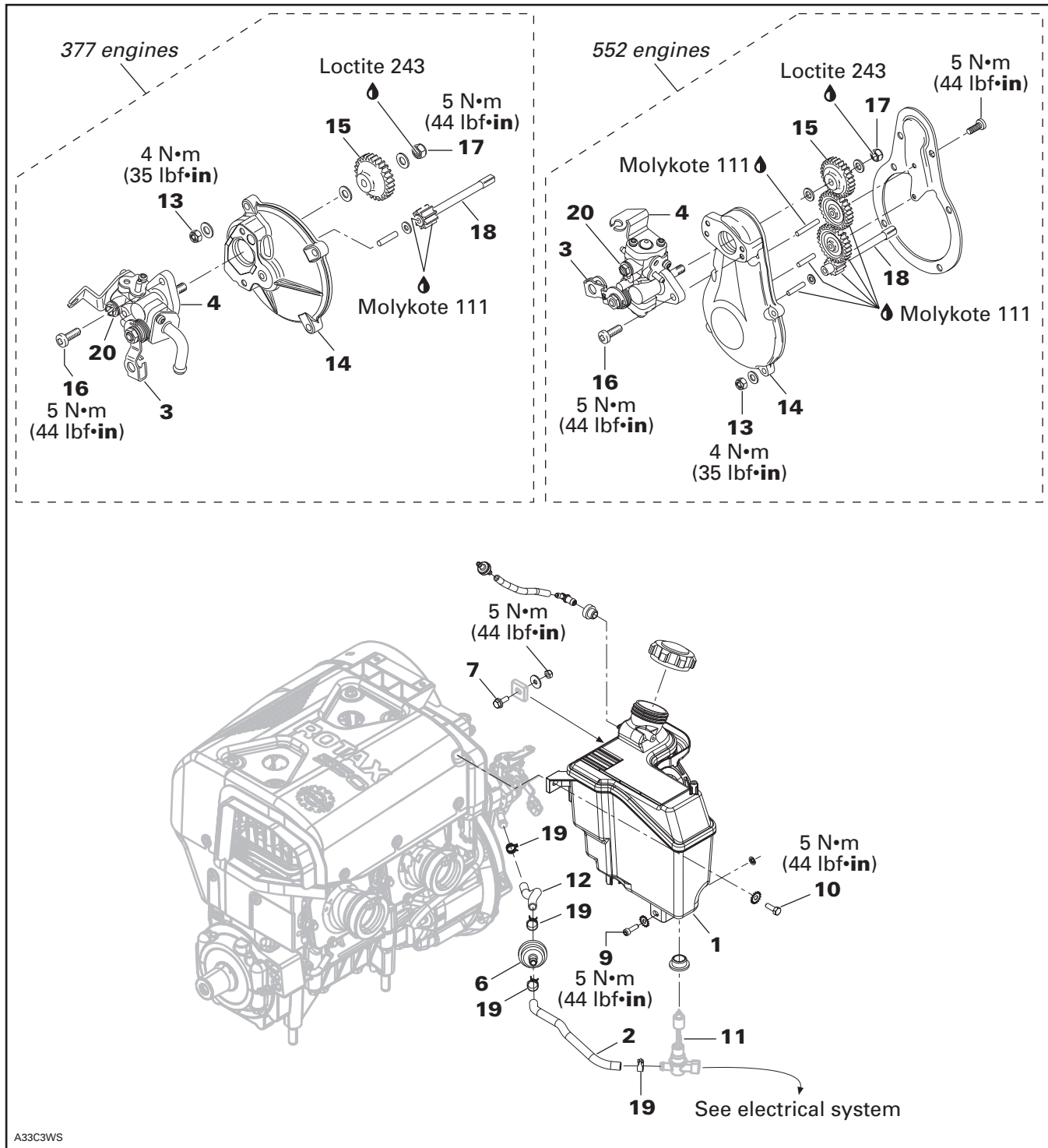

A33C3WS

Liquid-cooled Models

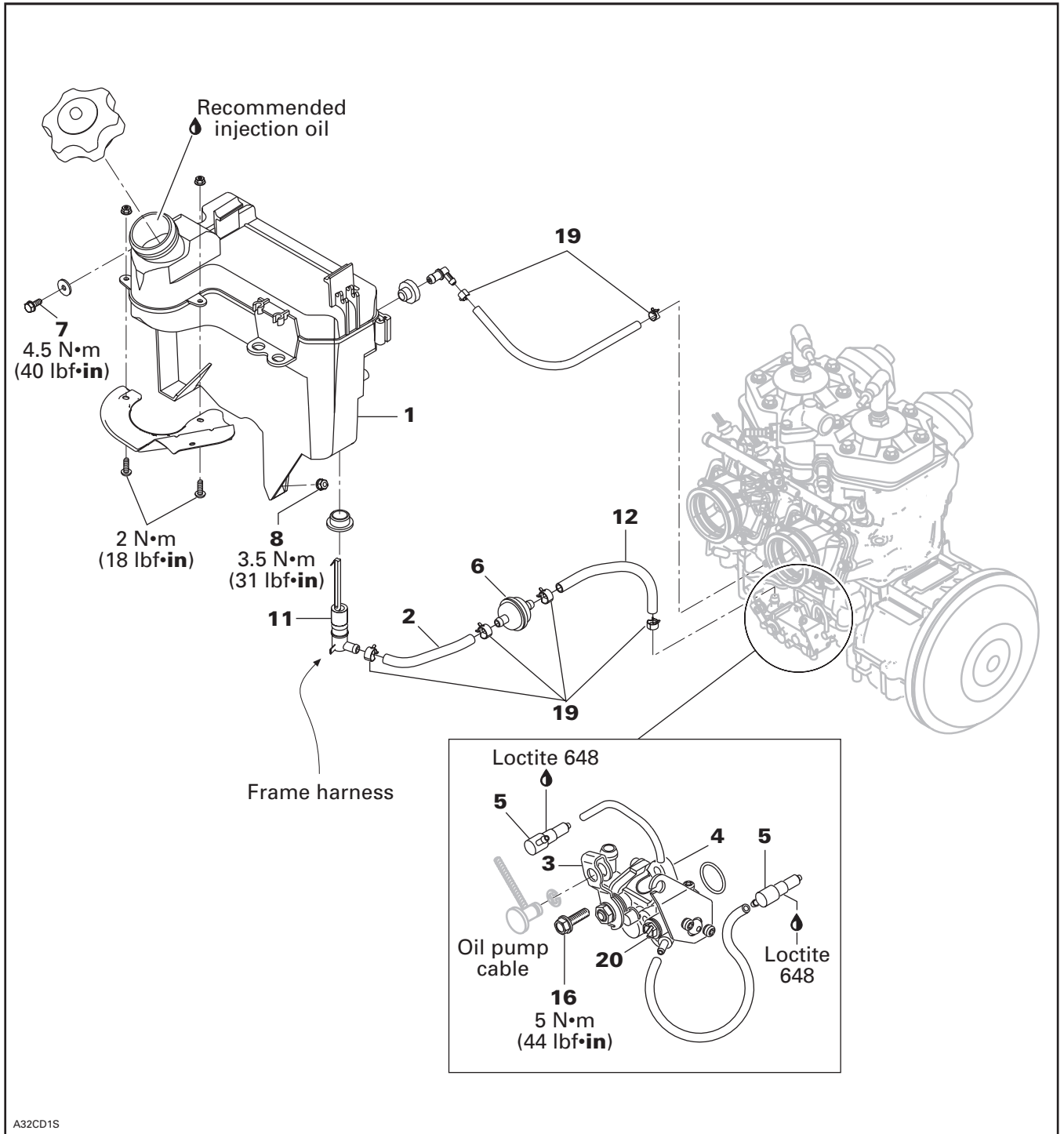

A32CD1S

Section 03 ENGINES

Subsection 10 (OIL INJECTION SYSTEM)

GENERAL

During assembly/installation, use the torque values and service products as in the exploded views.

Clean threads before applying a threadlocker. Refer to SELF-LOCKING FASTENERS and LOCTITE APPLICATION at the beginning of this manual for complete procedure.

WARNING

Torque wrench tightening specifications must strictly be adhered to.

Locking devices (e.g.: locking tabs, elastic stop nuts, self-locking fasteners, etc.) must be installed or replaced with new ones where specified. If the efficiency of a locking device is impaired, it must be renewed.

WARNING

Wipe off any oil spills. Oil is highly flammable.

NOTE: The following procedures can be done without removing the engine from chassis.

OIL TYPE

MODEL	OIL TYPE
2-TEC SDI	XP-S synthetic 2-stroke oil or XP-S synthetic blend 2-stroke oil ⁽¹⁾
All others 2-stroke engines	All XP-S 2-stroke oil (synthetic, synthetic blend or mineral) can be used. ^{(2) (3)}

- (1) **CAUTION:** The XP-S synthetic 2-stroke oil and the XP-S synthetic blend 2-stroke oil are specially formulated and tested for the severe requirements of these engines. Use of any other brand two-stroke oil may void the limited warranty. Use only XP-S synthetic 2-stroke oil or XP-S synthetic blend 2-stroke oil. There is no known equivalent on the market for the moment. If a high quality equivalent were available, it could be used.
- (2) If XP-S 2-stroke oil (synthetic, synthetic blend or mineral) is not available, API TC high-quality low ash two-stroke injection oil may be used.
- (3) XP-S synthetic 2-stroke oil, XP-S synthetic blend 2-stroke and XP-S mineral injection oil are compatible, they can be mixed together.

OIL SYSTEM LEAK TEST

The following test will indicate any leak from oil reservoir no. 1 and all other component of oil system.

Install on oil reservoir special cap of leak testing kit (P/N 529 033 100).



Install hose pincher (P/N 295 000 076) on oil reservoir check valve outlet hose no. 2.

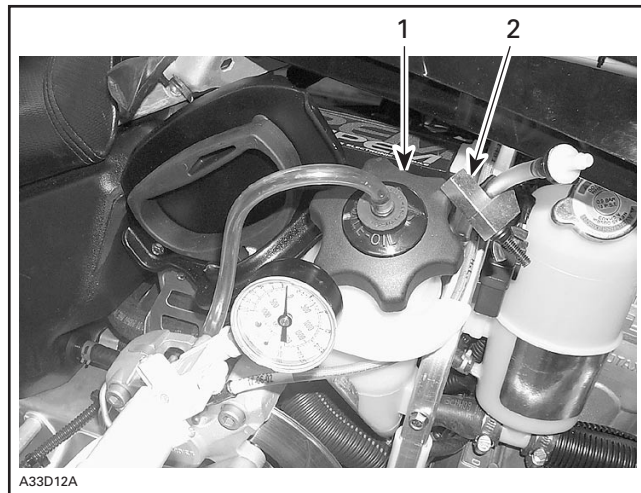
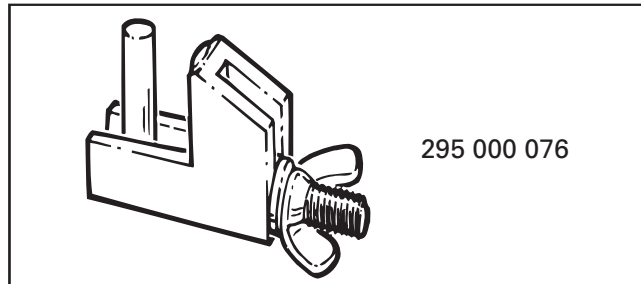

1. Special cap on reservoir
2. Hose pincher on check valve outlet hose

Remove air silencer and carburetor or throttle body to gain access to the oil pump hoses. Install small hose pincher (P/N 295 000 076) on outlet hoses.

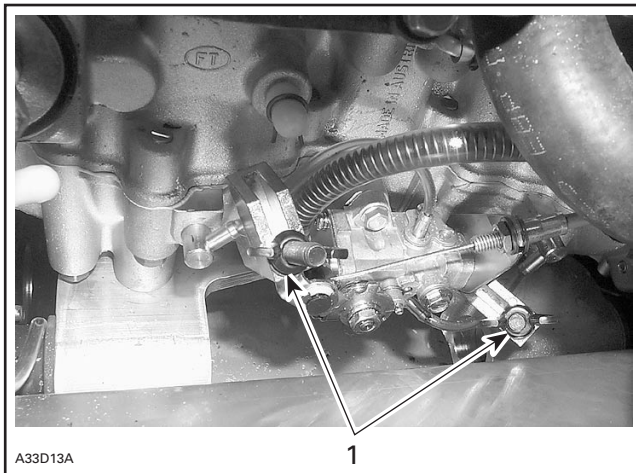

1. Hose pinchers on outlet hoses

Connect leak testing kit pump to special cap. Pressurize oil system to 21 kPa (3 PSI). That pressure must not drop during 3 minutes.

If pressure drops, locate leak(s) and repair/replace leaking component(s).

NOTE: An oil pump shaft test must be done to complete the oil system leak test. Refer to LEAK TEST AND ENGINE DIMENSION MEASUREMENT for the procedure.

OIL PUMP IDENTIFICATION

Different engines need different pumps. See identification on lever **no. 3**.

CAUTION: Always mount proper pump on engine.

ENGINE TYPE	OIL PUMP IDENTIFICATION
377	05
552	06
593, 593 HO and 593 HO SDI	02
793 HO	01
793 HO POWER TEK	08

CLEANING

Clean all metal components in a non-ferrous metal cleaner.

CHECKING OPERATION

Oil Pump

On Vehicle

NOTE: Main oil line must be full of oil. See bleeding procedure below.

Lift rear of vehicle and support with a mechanical stand. Unplug small oil lines from pump. Start engine and stop it as soon as it fires.

Check that oil in small oil lines has been sucked up (this will be indicated by a clear section of small oil lines). Repeat the procedure until this condition is attained.

Reconnect small oil lines, start engine and run at idle while holding the pump lever **no. 3** in fully open position. Oil columns must advance into small oil lines.

If not, remove pump assembly **no. 4** and check the pump gear and drive shaft (if applicable) for defects, replace as necessary. Test pump as describes below.

NOTE: Through normal use, oil level must not drop in small tubes. If oil drops, verify check valve **no. 5** operation in injection nozzle. Replace as necessary.

Test Bench

Connect a hose filled with injection oil to main line fitting. Insert other hose end in an injection oil container. Using a clockwise rotating drill rotate pump shaft. Oil must drip from outer fittings while holding lever in a fully open position. If not replace pump.

Check Valve

For all engines, check valve **no. 5** is part (built-in) of injection nozzle.

To verify the check valve, proceed the same as for checking pump operation on vehicle. First unplug oil line from check valve. After restarting the engine, check that a clear section in small oil line is present. Reconnect oil line.

Run engine at idle. Oil column must advance. If the check valve is faulty, oil column will go back and forth. Replace if so.

Section 03 ENGINES

Subsection 10 (OIL INJECTION SYSTEM)

Oil Reservoir Check Valve

It allows air to get into the reservoir. To verify this one-way check valve, remove it along with the hose. Make sure that it holds pressure and that it does not let air go through.

While installing this check valve make sure that the black side is towards the reservoir.

DISASSEMBLY

NOTE: Some oil pump components are not available as single parts.

Injection Oil Reservoir

Empty injection oil reservoir **no. 1** by siphoning injection oil.

Remove:

- air box
- upper screw **no. 7** (near reservoir cap)
- rewind starter support and grip
- hose protector support
- electronic module (if the module is located on the reservoir)
- lower nut **no. 8** or screw **no. 9** and **no. 10**.

NOTE: Cut the ties retaining the wiring harness if necessary.

Injection Oil Level Sensor

To remove the switch **no. 11**, use the following procedure.

Remove injection oil reservoir, as mentioned above.

Unplug switch connector.

Pull oil level switch **no. 7** out of reservoir.

Before replacing the injection oil level switch **no. 11**, check it according to the following procedure:

CAUTION: Do not remove or bend the reed switch protective float lock. It can damage the reed switch glass.

With the float magnet ring at the lowest position. Using an ohmmeter, probe the connector.

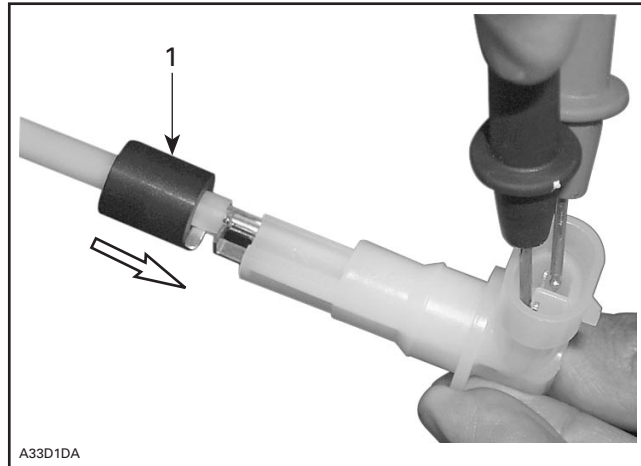

1. Float magnet at the lowest position

Reading below 0 ohm reflects the proper switch function. Replace the oil level switch if reading above 0 ohm.

Injection Oil Filter

Remove air box and carburetor or throttle body.

Siphon injection oil reservoir.

Disconnect oil filter hose **no. 2** from the reservoir **no. 1**.

Disconnect oil hoses **no. 2** and **no. 12** from the oil filter **no. 6** and remove it.

Injection Oil Pump

NOTE: Before removing the injection oil pump **no. 4**, check its operation. Refer to CHECKING OPERATION, above in this section.

Fan-cooled Models

Drain injection oil reservoir.

Remove the muffler.

Disconnect oil pump cable.

Install a hose pincher (P/N 295 000 076) on each oil pump outlet hoses then disconnect them.

NOTE: Mark hoses locations for installation.

Unscrew nut **no. 13**.

Remove oil pump mounting flange **no. 14**.

Remove oil pump gear **no. 5**.

Remove screws **no. 16**.

Remove oil pump.

Liquid-cooled Models

Remove:

- air box
- carburetor or throttle body
- screw **no. 16**.

Unplug all hoses connected to oil pump **no. 4**.

NOTE: Mark hose locations for installation.

Disconnect the oil pump cable.

Oil Pump Gear

Fan-cooled Models

Remove the oil pump from engine.

To remove the gear retaining nut **no. 17**, first extract the needle roller **no. 18** with pliers then lock gear in place using the gear holder (P/N 420 876 695).

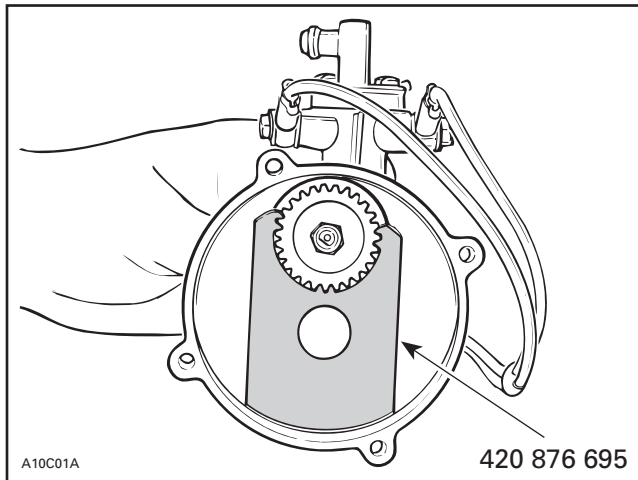

TYPICAL

Separate the oil pump from the pump mounting flange **no. 14** by removing oil pump screws **no. 16**.

Check Valve

Liquid-cooled Models

NOTE: Before removing check valve **no. 5**, check its operation. Refer to the end of this section.

Remove air box and carburetor or throttle body.

Clean check valve area to remove oil or dirt.

Heat check valve **no. 5** then pull it out of crankcase.

ASSEMBLY

CAUTION: Always bleed oil pump when the system has been opened.

NOTE: During installation, always check for spring clips **no. 19** tightness.

Injection Oil Reservoir

For installation, reverse the removal procedure.

Injection Oil Level sensor

For installation, reverse the removal procedure.

Injection Oil Filter

For installation, reverse the removal procedure.

NOTE: The filter must be installed with the arrow pointing toward the pump.

Injection Oil Pump

For installation, reverse the removal procedure. However, pay attention to the following.

Torque the screws **no. 16** to 5 N•m (44 lbf•in).

Make sure cable barrel is well seated in oil pump lever.

Secure barrel with plastic washer and circlip.

Install cable lock washer on left side of support.

Verify cable and oil pump lever operation then adjust cable.

Oil Pump Gear

Fan-cooled Models

The installation is the reverse of the removal procedure. However, pay attention to the following details.

At gear assembly, apply a light coat of Molykote 111 (P/N 413 707 000) on gear teeth.

The needle roller **no. 18** must be engaged as deep as possible in the pump mounting flange.

Check Valve

Liquid-cooled Models

Prior to coating it with Loctite, make sure check valve body is clean and dry. Clean from dirt or oil, if any, with pulley flange cleaner (P/N 413 711 809).

Apply Loctite 648 (green) (P/N 413 711 400) on the outer diameter of the check valve (machined section). Take care that Loctite is ONLY in this area.

Section 03 ENGINES

Subsection 10 (OIL INJECTION SYSTEM)

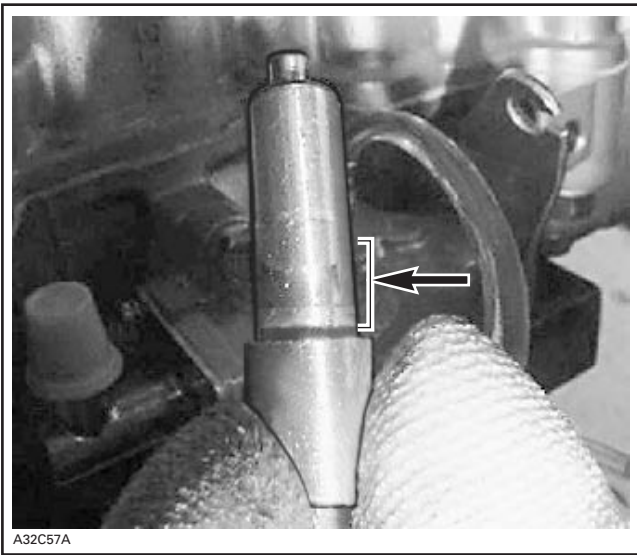

APPLY LOCTITE ON THIS AREA ONLY

Install the check valve in the correct position as described on next photos into the crankcase lower side.

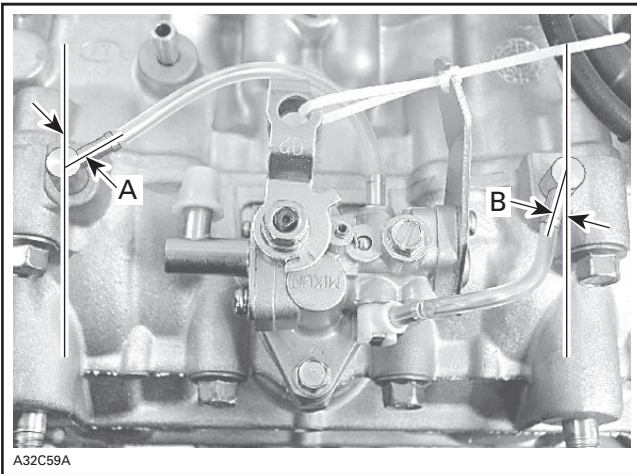

TYPICAL

- A. PTO side $45^\circ \pm 5^\circ$ from cylinder axis to the top
- B. MAG side $20^\circ \pm 5^\circ$ from cylinder axis to the bottom

Punch in the check valve carefully with a plastic hammer.

Clean the crankcase from surplus of Loctite 648 with a rag.

BLEEDING PROCEDURE

Bleed main oil line (between reservoir and pump) by loosening the bleeder screw no. 20 until air has escaped from the line. Add injection oil as required.

Reinstall all parts.

Bleed the small oil line between pump and engine by running engine at idle while holding the pump lever in fully open position.

NOTE: Make a J hook out of mechanical wire to lift the lever.

WARNING

No ensure not operate carburetor throttle mechanism. Secure the rear of the vehicle on a stand.

ADJUSTMENT

Oil Pump Cable

Fan-cooled Models

Prior to adjusting the pump, make sure all carburetor adjustments are completed and engine is stopped.

Eliminate the throttle cable free-play by pressing the throttle lever until a light resistance is felt, then hold in place.

The mark on the pump casting and on the lever must align. Width of lever mark is the tolerance.

Loosen the adjuster nut and adjust accordingly.

Retighten the adjuster nut.

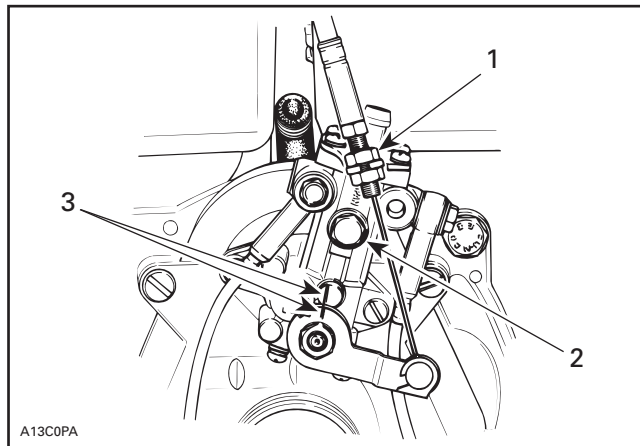

TYPICAL

- 1. Adjuster nut
- 2. Bleeder screw
- 3. Marks

CAUTION: Proper oil injection pump adjustment is very important. Any delay in the opening of the pump can result in serious engine damage.

Section 03 ENGINES
Subsection 10 (OIL INJECTION SYSTEM)

Liquid-cooled Models

Before processing with the oil pump cable adjustment, verify throttle cable adjustment. Refer to CARBURETOR AND THROTTLE CABLE or COMPONENT INSPECTION, REPLACEMENT AND ADJUSTMENT (SDI models).

Depress the throttle lever lightly until the cable is under tension but carburetors or throttle body are not yet opened.

Using a feeler gauge, measure the visible distance between throttle lever and the end of cable housing.

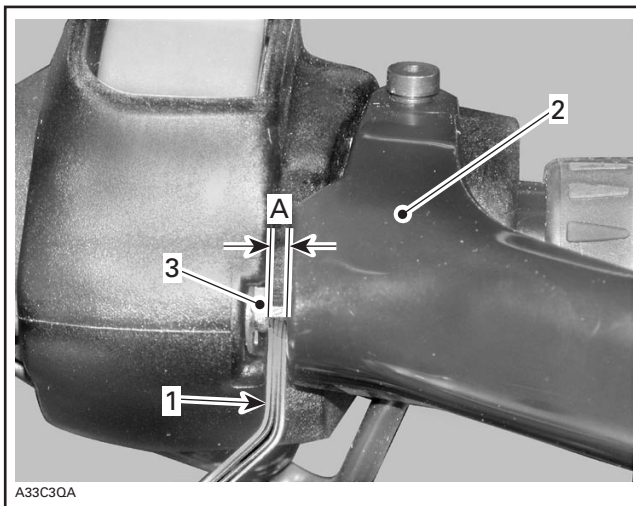

- 1. Feeler gauge
- 2. Throttle lever
- 3. End of cable housing
- A. Visible distance

Note this measure.

Next, add to measurement "A" the appropriate specification "B", using the chart below.

ENGINE TYPE	SPECIFICATION "B"
All liquid-cooled engines except SDI models	16.5 mm (.650 in)
SDI engines	18 mm (.709 in)

Stretch oil pump cable with a force of 32 N (7.2 lbf) and measure the length of its visible distance "C".

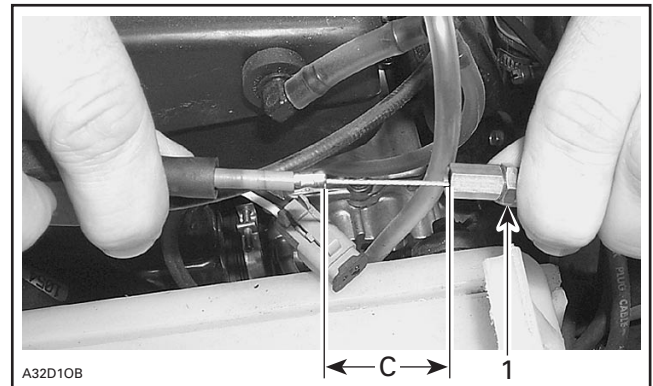

- 1. Adjusting screw lock nut
- C. Visible distance for oil pump adjustment

If the visible distance is less or more than "A" + "B", adjust cable distance. To do so, loosen lock nut, turn adjusting screw in or out and retighten lock nut.

FUEL TANK AND FUEL PUMP

SERVICE TOOLS

Description	Part Number	Page
hose pincher.....	295 000 076	168, 174
leak tester kit.....	529 033 100	171
vacum/pressure pump kit.....	529 021 800	171
wrench.....	529 035 891	169

Section 04 FUEL SYSTEM

Subsection 01 (FUEL TANK AND FUEL PUMP)

All Models except SDI

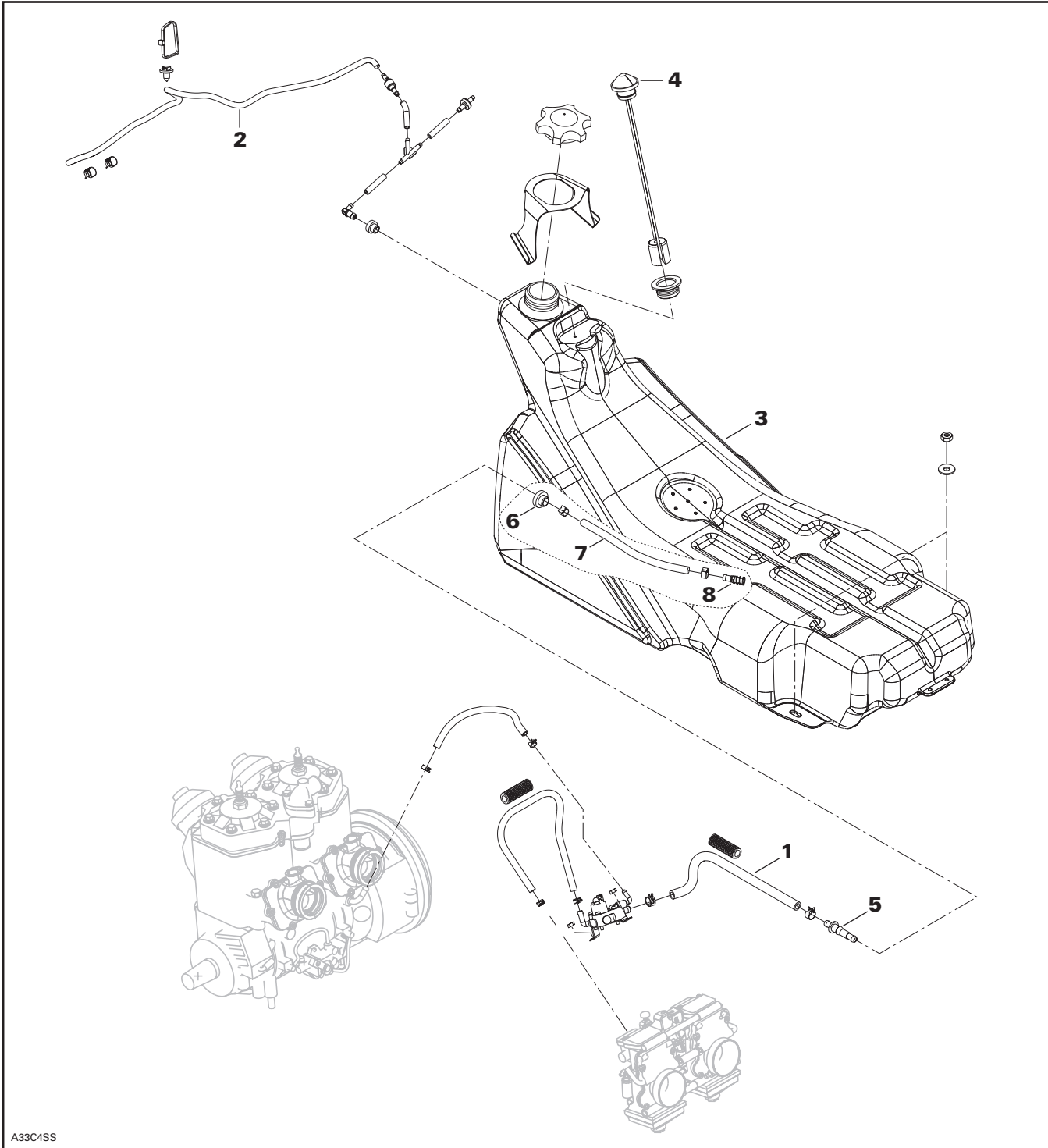

A33C4SS

Section 04 FUEL SYSTEM
Subsection 01 (FUEL TANK AND FUEL PUMP)

SDI Models

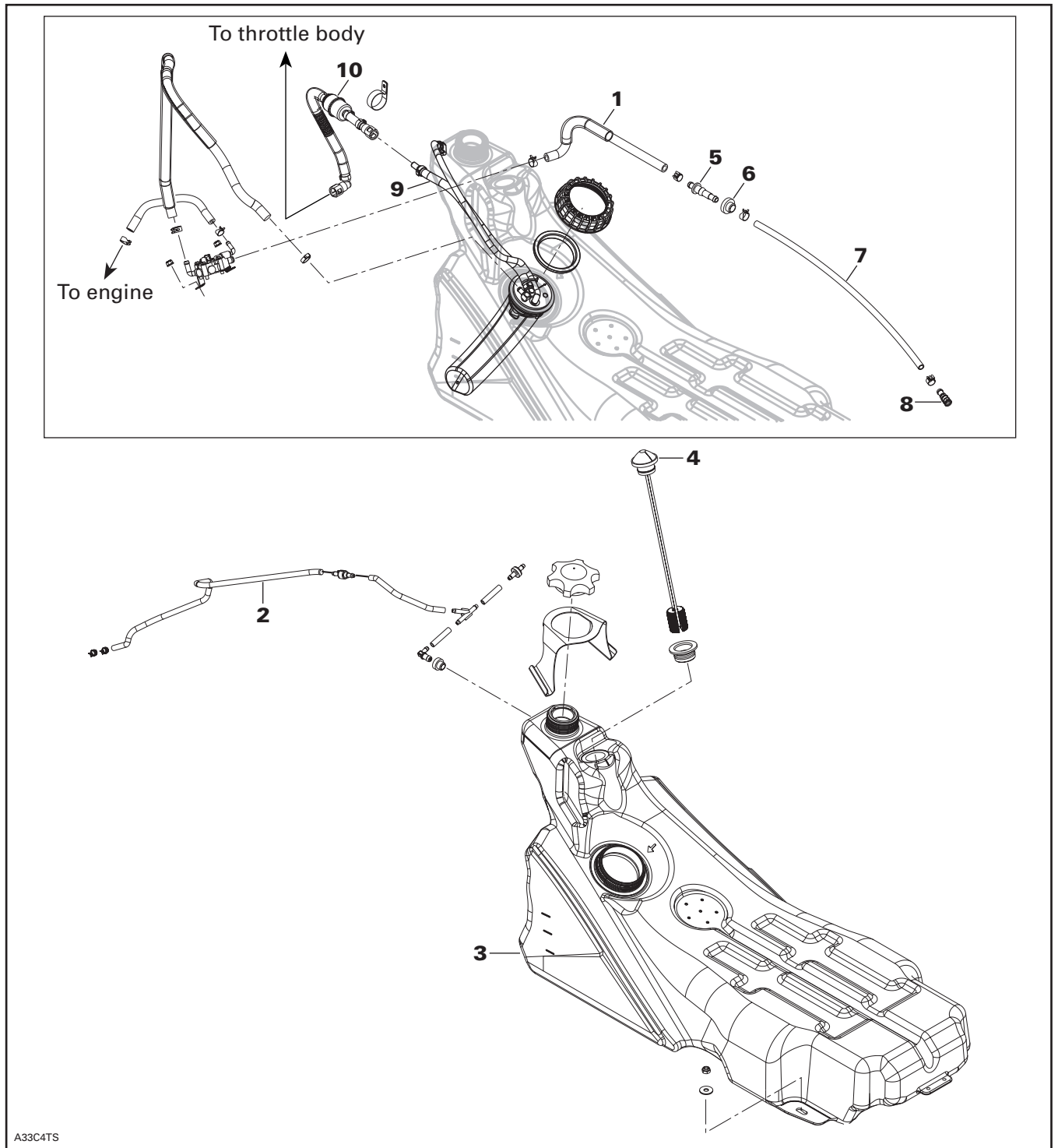

A33C4TS

Section 04 FUEL SYSTEM

Subsection 01 (FUEL TANK AND FUEL PUMP)

IN-TANK FUEL FILTER

Replacement

Drain fuel tank.

Install a hose pincher (P/N 295 000 076) on supply hose then, unplug support hose.

Pull out male connector **no. 5** from grommet.

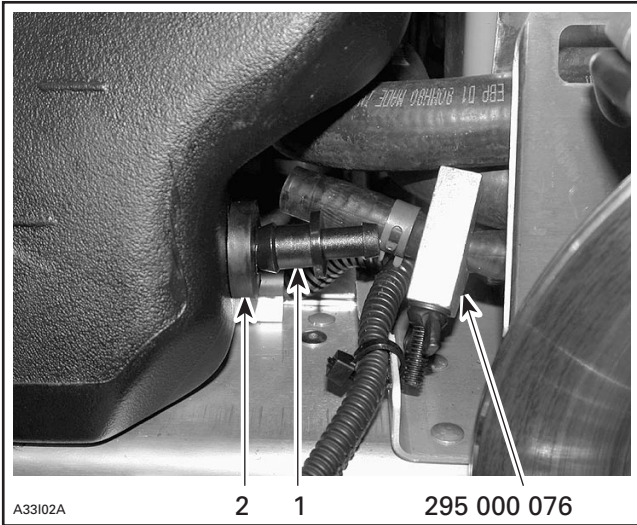

1. Male connector
2. Grommet

Pull out grommet **no. 6** from fuel tank **no. 3** then, pull out pickup hose **no. 7** and fuel filter **no. 8**.

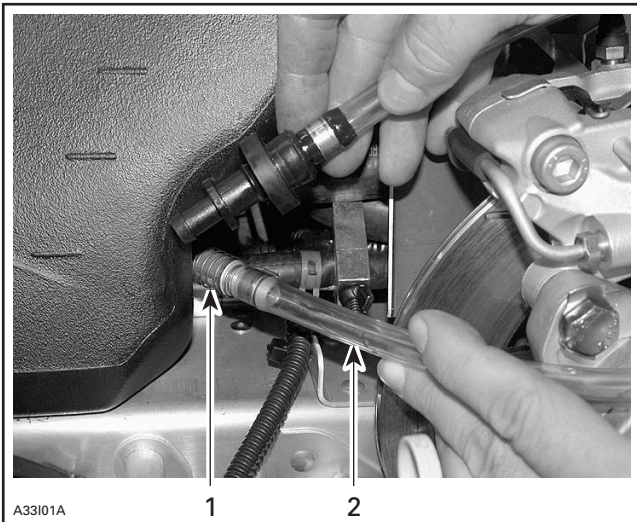

1. Fuel filter
2. Pickup hose

Replace fuel filter and grommet. To facilitate the installation, grommet should be on smaller diameter of male connector. Install grommet on fuel tank and push male connector through grommet.

IN-LINE FUEL FILTER

Replacement

SDI Models Only

⚠ WARNING

Fuel lines remain under pressure at all times. Always proceed with care and use appropriate safety equipment when working on pressurized fuel system. Wear safety glasses and work in a well ventilated area. Do not allow fuel to spill on hot engine parts and/or on electrical connectors. Proceed with care when removing/installing high pressure test equipment or disconnecting fuel line connections. Use the VCK to release fuel pressure prior to removing a hose. Cover the fuel line connection with an absorbent shop rag. Slowly disconnect the fuel hose to minimize spilling. Wipe off any fuel spillage in the engine compartment. Fuel is flammable and explosive under certain conditions. Always disconnect battery prior to working on the fuel system.

Fuel filter, inlet and outlet hoses come as an assembly.

The fuel filter **no. 10** is located beside the steering column, next to coolant tank.

Using B.U.D.S. release the fuel pressure. Refer to COMPONENT INSPECTION, REPLACEMENT AND ADJUSTMENT.

Remove console to gain access to top of fuel pump module.

Disconnect both ends of fuel filter line.

Unfasten clip retaining fuel line to fuse box support.

Unscrew the fuel filter support nut then remove the filter.

The installation is the reverse of removal procedure.

FUEL TANK

Removal

Remove seat, refer to BODY.

Remove fuel tank cap.

Remove filler neck plastic nut using wrench (P/N 529 035 891).



Unclip and remove console center trim cap.

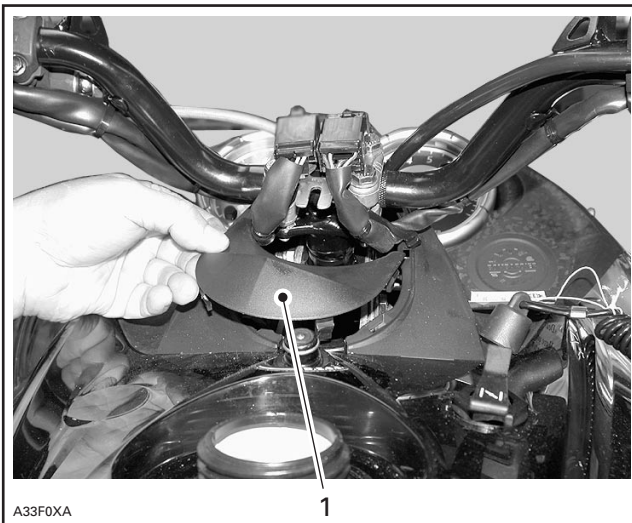

1. Remove this cap

Remove retaining screw on both sides of center console; this will allow lifting of console just enough to ease tank removal.



1. Remove this screw on both sides

Remove both sides fuel tank aluminum braces:

- by removing and discarding lower M8 x 20 Torx screws (2 on each side);
- and by removing upper M8 flanged hexagonal bolts (2 on each side) and discarding their nuts.

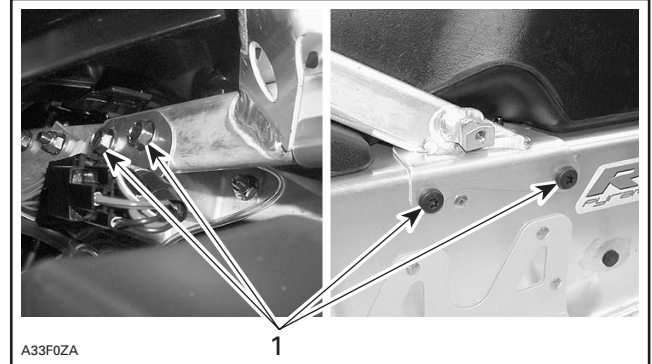

1. Remove and discard lower Torx screws on both sides — remove upper flanged hexagonal bolts and discard their nuts on both sides

Empty fuel tank and install a hose pincher on fuel line no. 1 as shown in following photo.

Section 04 FUEL SYSTEM

Subsection 01 (FUEL TANK AND FUEL PUMP)

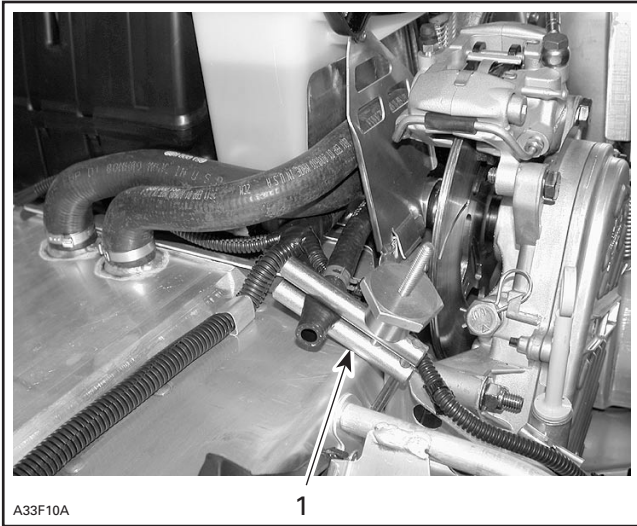

FUEL TANK REMOVED

1. Hose pincher installed on fuel line

SDI Models

Release fuel pressure of the system. Refer to COMPONENT INSPECTION, REPLACEMENT AND ADJUSTMENT.

Install a hose pincher on fuel pump hose no. 9 then disconnect it from fuel filter hose no. 10.

Unplug electric fuel pump connector.

All Models

WARNING

Whenever a fuel line is disconnected, obstruct line with a hose pincher. Fuel is flammable and explosive under certain conditions. Always wipe off any fuel or oil spillage from the vehicle. Ensure work area is well ventilated. Do not smoke or allow open flames or sparks in the vicinity.

Unplug vent tube no. 2 from tank.

If applicable, cut locking tie holding wiring harness to fuel tank at rear.

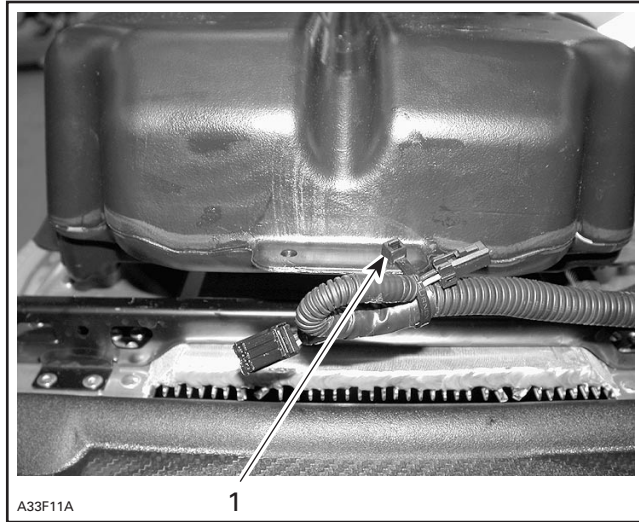

1. Cut this locking tie

Remove fuel tank no. 3 and set it aside.

Installation

Reinstall fuel tank and plug-in vent tube.

WARNING

Make sure vent tube is not kinked.

Connect fuel line and remove hose pincher.

Reinstall right and left fuel tank aluminum braces using new lower Torx screws (with Scotch Grip) and previously removed upper flanged hexagonal bolts with new M8 flanged elastic stop nuts.

Reinstall filler neck nut using special tool (P/N 529 035 891).

Reinstall fuel cap.

Reinstall center console.

Reinstall console center trim cap.

Reinstall seat.

SDI Models

Reinstall fuel filter hose.

Reconnect electric fuel pump connector.

Perform a fuel pressure test.

FLOAT-TYPE FUEL LEVEL GAUGE

To remove gauge no. 4 from fuel tank, pull gauge out of its grommet then remove grommet.

For reinstallation, proceed as follows:

- Install grommet halfway on gauge.

Section 04 FUEL SYSTEM

Subsection 01 (FUEL TANK AND FUEL PUMP)

- Insert grommet in fuel tank until it bottoms.
- Firmly push gauge in grommet until it bottoms and so that its red line aligns with the line on the fuel tank.

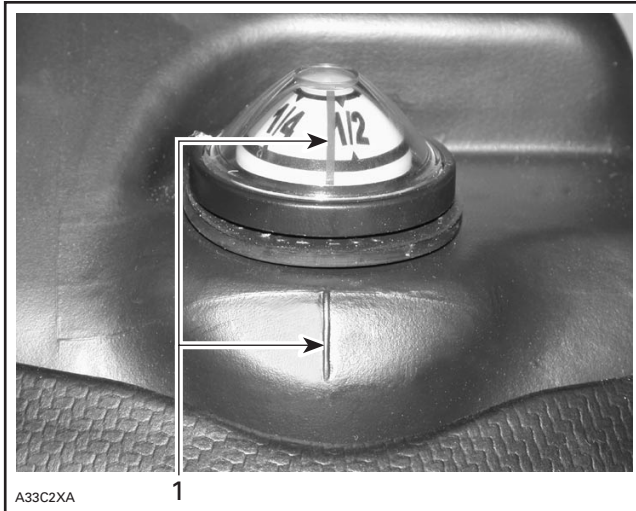

1. Align red line with line on tank

ELECTRIC FUEL LEVEL SENSOR

Inspection

All Models except SDI

Visually inspect the condition of connectors and wiring throughout the circuit. Connections must be clean and tight, and wiring free of damage. Repair as necessary. Use silicone dielectric grease to prevent corrosion at the connectors. Operate the engine to see if the problem has been corrected.

A 0.25 ampere fuse protects fuel level sensor circuitry. Remove seat to gain access.

Torque fuel level sensor retaining screws to 1 N•m (8 lbf•in) in a criss-cross sequence and then to 2.4 N•m (21 lbf•in), using the same sequence.

SDI Models

Fuel level sensor is integrated to the fuel pump. Refer to COMPONENT INSPECTION, REPLACEMENT AND ADJUSTMENT.

A 0.5 amp. fuse protects fuel level sensor circuitry in fuse box.

FUEL SYSTEM PRESSURIZATION

Fill up fuel tank.

Install on fuel tank, the special cap of leak tester kit (P/N 529 033 100).

Using vacuum/pressure pump kit (P/N 529 021 800), inject air into fuel tank. See next photo.

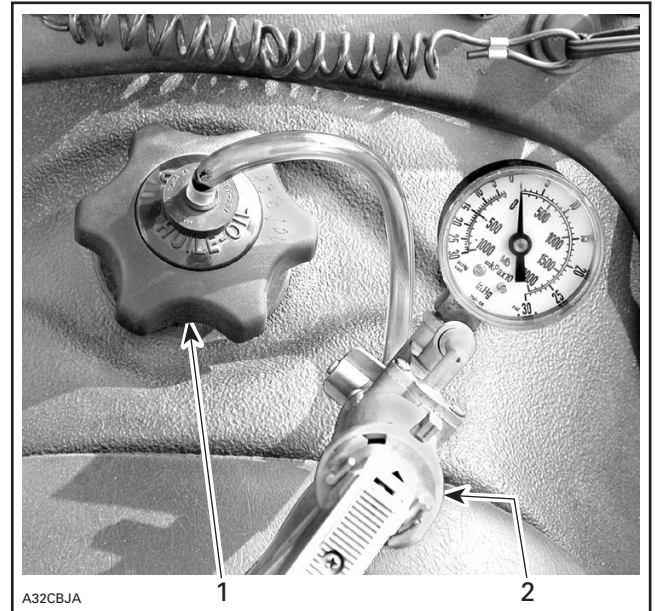

TYPICAL

1. Special cap on tank
2. Air pump

Pressurize fuel system to 21 kPa (3 PSI). The pressure must not drop during 3 minutes.

If pressure drops, locate fuel leak(s) and repair/replace leaking component(s).

To ease locating leak(s) at fuel tank vent fitting, fuel gauge or fuel cap, spray soapy water on components; bubbles will indicate leak location(s).

High Pressure Test (Electric Fuel Pump Circuit)

SDI Models Only

Install tether cord on DESS post. Push the emergency switch to OFF position. Push on start button to activate fuel pump.

Check for any leakage at fuel rail, injectors, in-line fuel filter and fuel hose.

Section 04 FUEL SYSTEM

Subsection 01 (FUEL TANK AND FUEL PUMP)

DIAPHRAGM FUEL PUMP

All Models except SDI

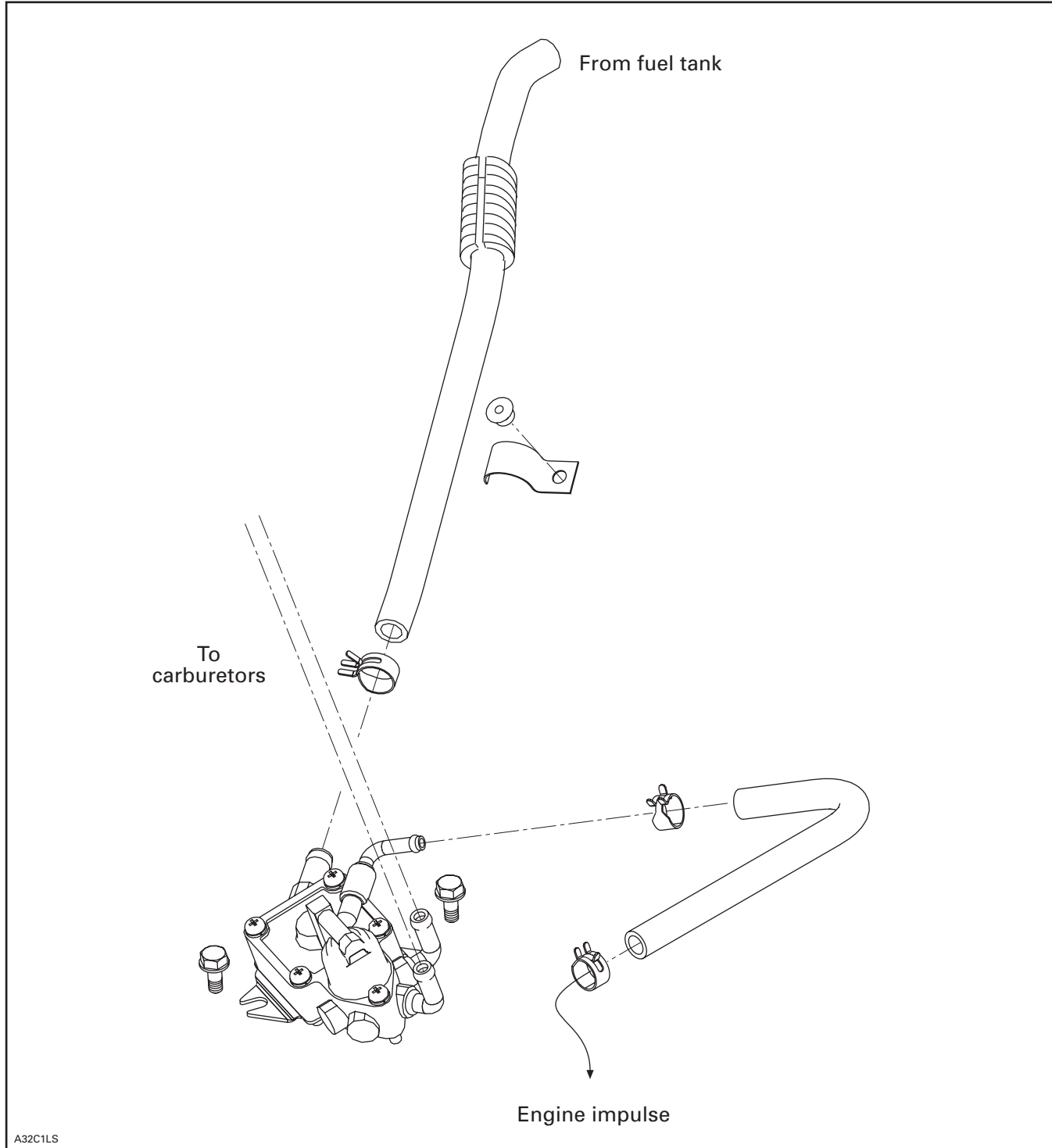

A32C1LS

Section 04 FUEL SYSTEM
Subsection 01 (FUEL TANK AND FUEL PUMP)

SDI Models

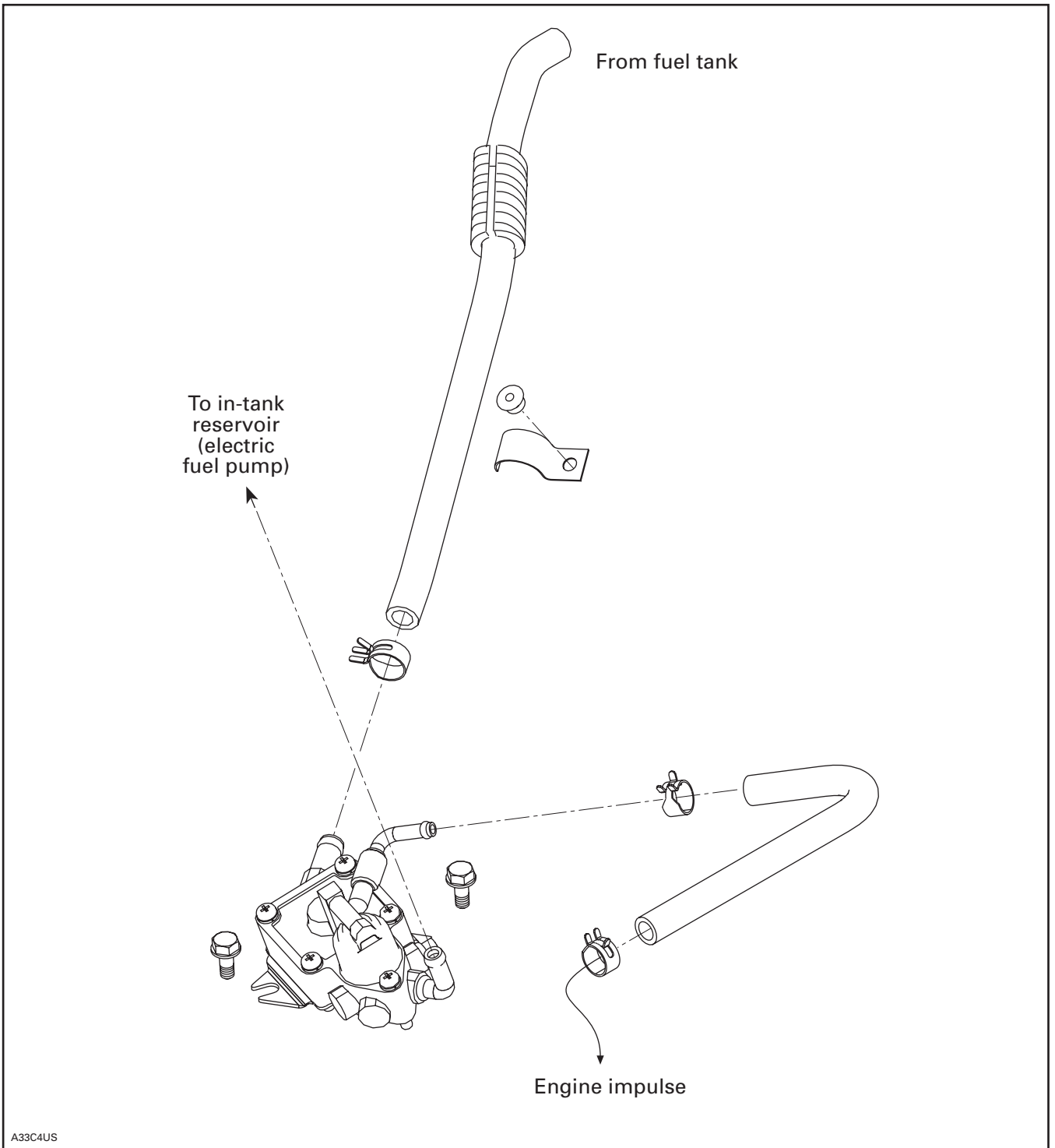

A33C4US

Section 04 FUEL SYSTEM

Subsection 01 (FUEL TANK AND FUEL PUMP)

NOTE: The following instructions are applicable on SDI models for the diaphragm fuel pump. See COMPONENT INSPECTION, REPLACEMENT AND ADJUSTMENT concerning the electric fuel pump.

REMOVAL

Remove air intake silencer and carburetors (throttle body for the SDI models).

NOTE: Do not disconnect cables from carburetors or throttle body.

Install a hose pincher (P/N 295 000 076) on fuel supply line close to pump inlet.

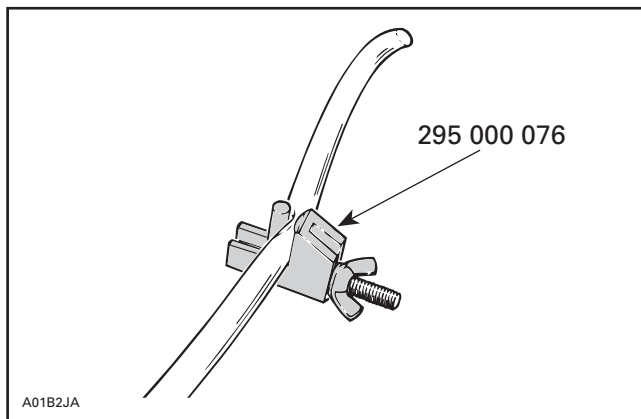

Disconnect fuel outlet line(s).

Disconnect impulse line.

Remove screws securing fuel pump to chassis.

PUMP VERIFICATION

Check fuel pump valves operation as follows:

Connect a clean plastic tubing to the inlet nipple and alternately apply pressure and vacuum with pump of leak test kit. The inlet valve should release with pressure and hold under vacuum.

Repeat the same procedure at the outlet nipple. This time the outlet valve should hold with pressure and also under vacuum.

NOTE: Plug remaining outlet with finger while checking outlet valve.

Check impulse diaphragm and gasket on fuel pump with twin outlets as follows:

Connect a clean plastic tubing to the impulse nipple and plug vent hole on top cover on so equipped models. Either apply pressure or vacuum. The diaphragm/gasket must not leak.

CLEANING AND INSPECTION

The entire pump should be cleaned with general purpose solvent before disassembly.

Fuel pump components should be cleaned in general purpose solvent and dried with compressed air.

⚠ WARNING

Solvent with low flash point such as gasoline, naphtha, benzol, etc, should not be used as each is flammable and explosive.

Inspect diaphragm. The pumping area should be free of holes, tears or imperfections. Replace as needed.

INSTALLATION

Inverse removal procedure.

⚠ WARNING

Pressure test to ensure there is no leak in fuel system.

CARBURETORS, THROTTLE AND CHOKE CABLES

SERVICE TOOLS

Description	Part Number	Page
carburetor tool kit	404 112 000	177–178, 187–188
choke plunger tool	529 035 602	182
float gauge	529 035 520	179

Section 04 FUEL SYSTEM

Subsection 02 (CARBURETORS, THROTTLE AND CHOKE CABLES)

CARBURETOR — VM TYPE

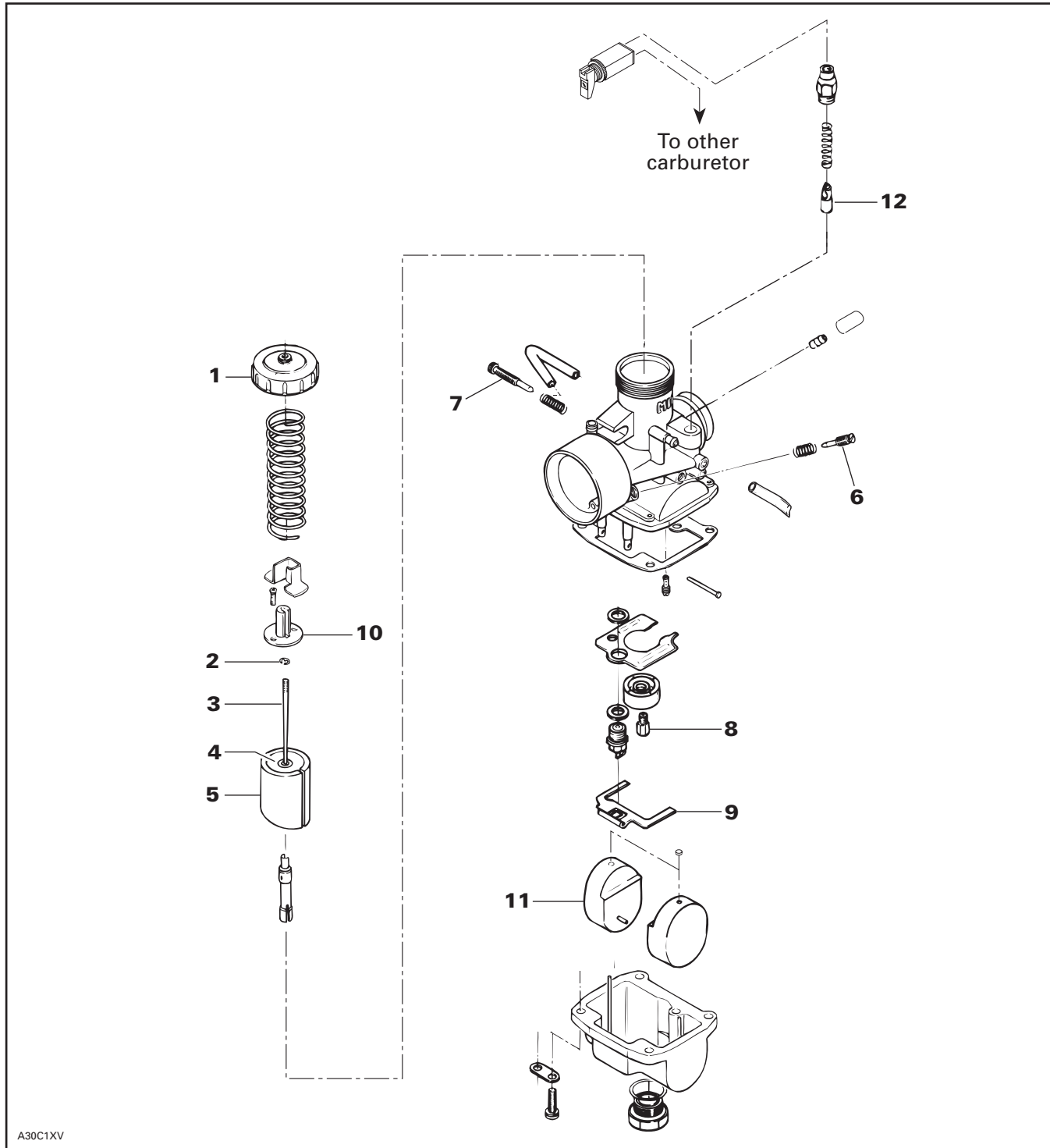

IDENTIFICATION

All carburetors are identified on their body.

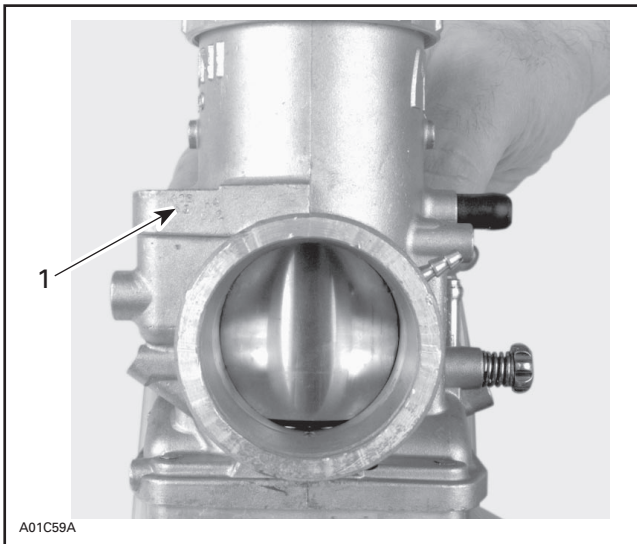

TYPICAL
1. Identification: 34-482

REMOVAL

Lift hood and open LH side panel.

Disconnect carburetor vent hose from air intake silencer.

Loosen clamps retaining air intake silencer adapter to carburetors.

Remove air intake silencer.

NOTE: The following procedure applies to both carburetors. Carburetors can be removed individually.

Disconnect fuel inlet line.

Unscrew carburetor cover **no. 1** then pull out throttle slide **no. 5** from carburetor.

Disconnect throttle cable from throttle slide.

Loosen clamp retaining carburetor to intake adapter.

Remove carburetor from engine.

Unscrew choke plunger from carburetor.

CLEANING AND INSPECTION

The entire carburetor should be cleaned with a general solvent and dried with compressed air before disassembly.

CAUTION: Heavy duty carburetor cleaner may be harmful to the float material and to the rubber parts, O-rings, etc. Therefore, it is recommended to remove those parts prior to cleaning.

Carburetor body and pilot/main jets should be cleaned in a carburetor cleaner following manufacturer's instructions.

WARNING

Solvent with a low flash point such as gasoline, naphtha, benzol, etc., should not be used as they are flammable and explosive.

Check inlet needle tip condition. If worn, the inlet needle and seat must be replaced as a matched set.

NOTE: Install needle valve for snowmobile carburetor only. It is designed to operate with a fuel pump system.

Check throttle slide **no. 5** for wear. Replace as necessary.

Check idle speed screw straightness. Replace as necessary.

Check for fuel soaked into float **no. 11**; replace as necessary.

Check float for cracks or other damages affecting free movement; replace as necessary.

Inspect throttle cable and housing for any damages. Replace as necessary.

DISASSEMBLY AND ASSEMBLY

NOTE: To ease the carburetor disassembly and assembly procedures it is recommended to use carburetor tool kit (P/N 404 112 000).

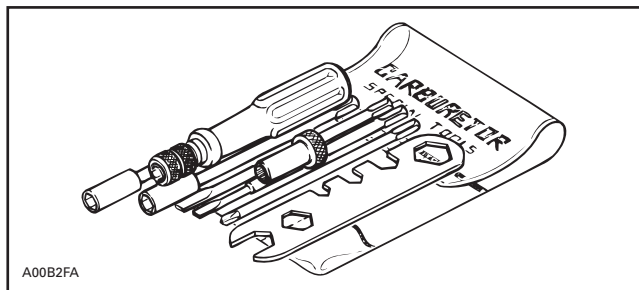

E-Clip and Needle

Remove screws from needle retaining plate **no. 10** to remove the needle **no. 3**.

Section 04 FUEL SYSTEM

Subsection 02 (CARBURETORS, THROTTLE AND CHOKE CABLES)

Float Bowl

Unscrew drain plug of float bowl. Recover the remaining fuel in a container.

Unscrew the 4 screws retaining the float bowl to the carburetor body. Remove float bowl.

NOTE: Upon float bowl removal, make sure not to drop carburetor floats.

Needle Valve Assembly

Remove float bowl as explained above.

Pull out pin retaining float arm to carburetor body. Remove float arm.

Unscrew needle valve.

Pilot Jet

Remove float bowl as explained above.

Unscrew pilot jet using narrow screwdriver from carburetor tool kit (P/N 404 112 000).

Main Jet

Remove float bowl as explained above.

Unscrew main jet from carburetor body.

NOTE: To replace main jet by a different size, main jet is accessible through the drain plug without removing float bowl.

CARBURETOR ADJUSTMENTS

NOTE: Carburetor is calibrated at the factory for a temperature of -20°C (0°F) at sea level. For colder temperature or high altitude applications, carburetor must be recalibrated. A Service Bulletin gives information about carburetor calibration according to altitude and temperature.

Adjustments should be performed following this sequence:

- float arm adjustment
- e-clip and needle
- air screw adjustment
- throttle slide height (preliminary idle speed adjustment)
- throttle cable adjustment
- carburetor synchronization
- idle speed adjustment (engine running)

CAUTION: Oil pump cable must be readjusted whenever throttle cable or idle speed adjustment are changed, otherwise serious engine damage may occur.

Float Arm

CAUTION: Spark plugs will foul if float is adjusted too low. Engine may be damaged if float is adjusted too high.

Correct fuel level in float chamber is vital toward maximum engine efficiency. To check for correct float level proceed as follows:

- Make sure that float arm no. 9 is symmetrical — not distorted.
- Remove float bowl and gasket from carburetor.
- With carburetor chamber upside-down on a level surface, measure height H between bowl seat and top edge of float arm. Keep ruler perfectly vertical and in line with main jet hole.

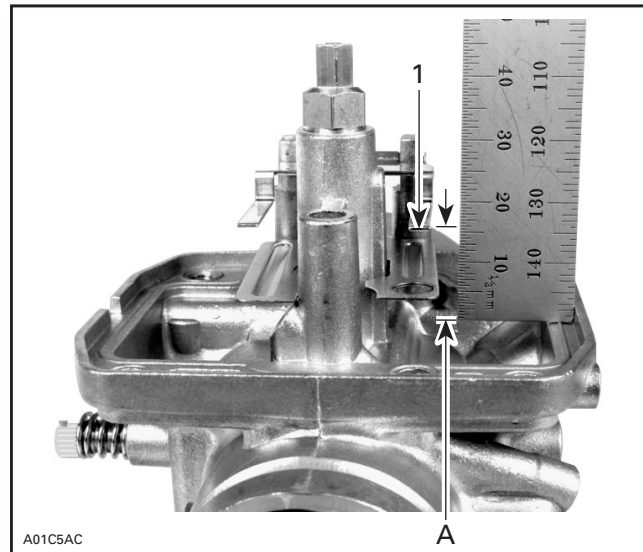

TYPICAL — VM TYPE

1. Measure from top of float arm

A. Float height (including float arm thickness)

Section 04 FUEL SYSTEM
Subsection 02 (CARBURETORS, THROTTLE AND CHOKE CABLES)

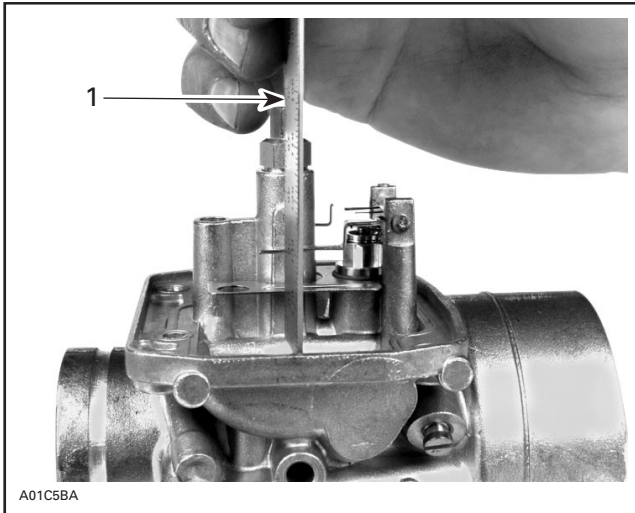

TYPICAL — VM TYPE
1. Ruler vertical and in line with main jet

Float level height can be checked using float gauge (P/N 529 035 520). Keep tool in line with main jet as explained above.

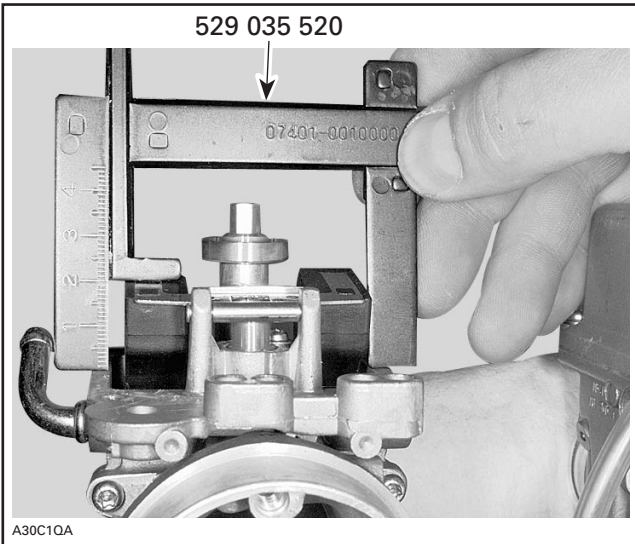

CARBURETOR	FLOAT HEIGHT
VM 30-213 (377 engine)	23.9 ± 1.0 mm
VM 34-617 (552 engine)	(.941 ± .039 in)

To Adjust Height

- Bend the contact tab of float arm until the specified height is reached.

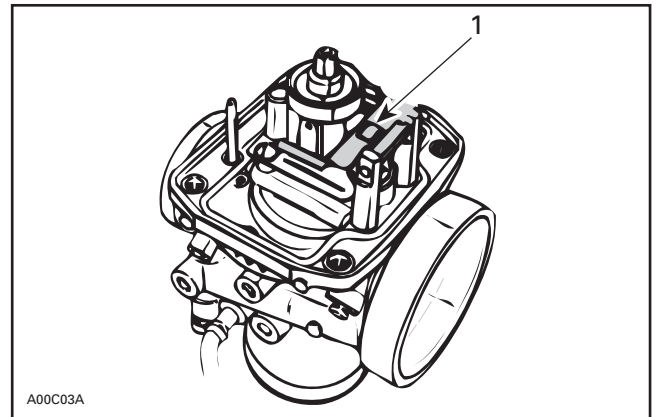

TYPICAL
1. Contact tab

E-Clip and Needle

The position of the needle in the throttle slide is adjustable by means of an E-clip **no. 2** inserted into 1 of 5 grooves located on the upper part of the needle. Position 1 (at top) is the leanest, 5 (at bottom) the richest.

NOTE: The last digit of the needle identification number gives the recommended calibrated position of the E-clip **from the top** of the needle.

EXAMPLE: 6DH4-3

Needle identification Recommended position of the E-clip from top

A00C6FA

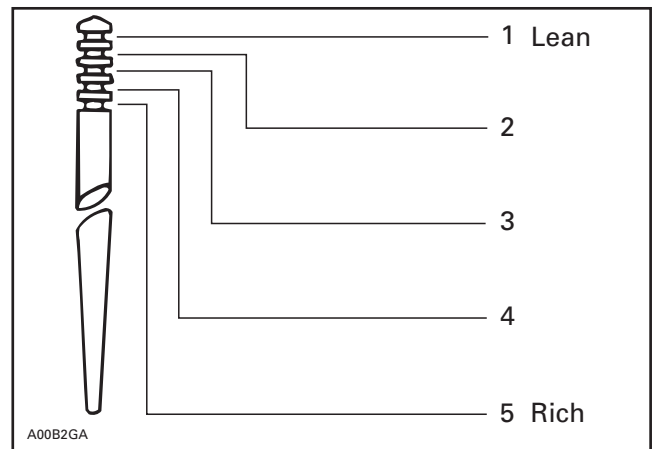

CLIP POSITIONS

Section 04 FUEL SYSTEM

Subsection 02 (CARBURETORS, THROTTLE AND CHOKE CABLES)

Air Screw Adjustment

Completely close the **air screw no. 6** (until a slight seating resistance is felt) then back off as specified.

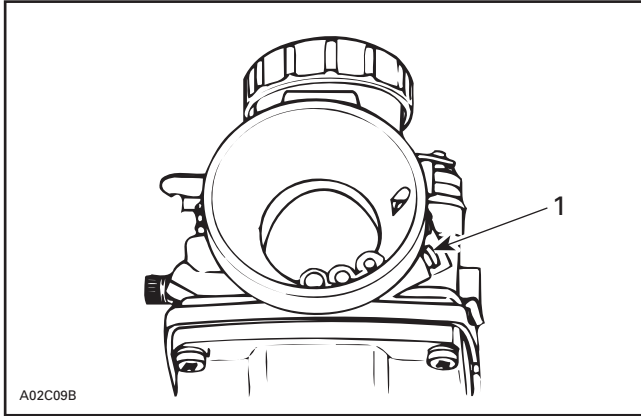

1. Air screw

NOTE: Turning screw in clockwise enriches mixture and conversely, turning it out counterclockwise leans mixture.

CARBURETOR	AIR SCREW
VM-30 213 (377 engine)	2.0 turns
VM-34-617 (552 engine)	2.0 turns

Throttle Slide Height (preliminary idle speed adjustment)

Hook throttle cable into the needle retainer plate.

NOTE: Do not obstruct hole in throttle slide when installing needle retaining plate. This is important to allow air escaping through and thus allowing a quick response.

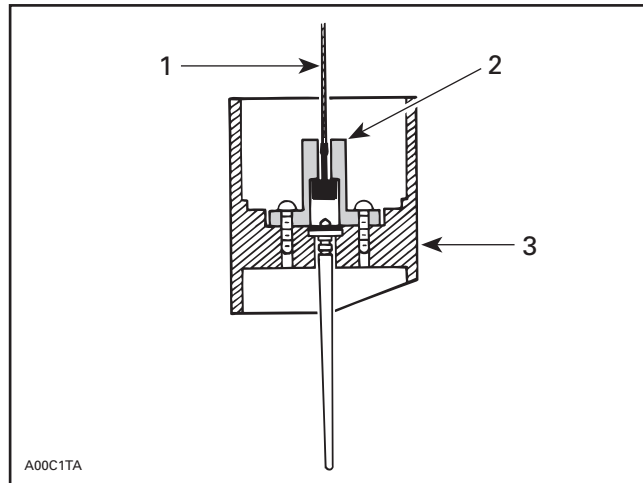

CENTER POST TYPE

1. Throttle cable
2. Needle retaining plate
3. Throttle slide

Make sure the nylon packing **no. 4** is installed on all applicable throttle slides.

CAUTION: Serious engine damage can occur if this notice is disregarded.

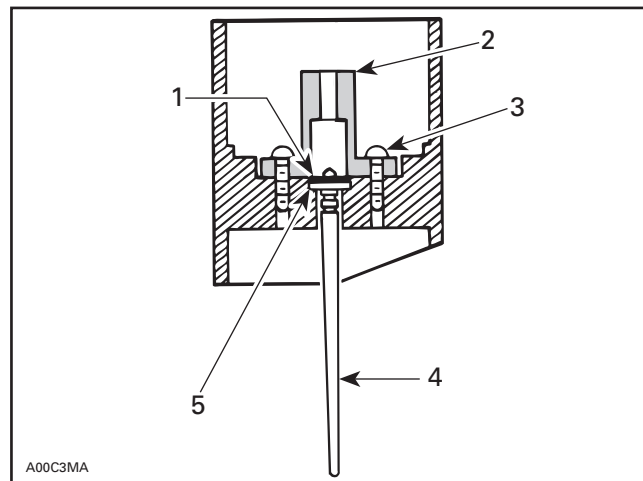

CENTER POST TYPE

1. E-clip
2. Needle retaining plate
3. Screw
4. Needle
5. Nylon packing

Using a drill bit, adjust throttle slide height (see following table) by turning idle speed screw **no. 7**.

Throttle slide height is measured on outlet side of carburetor (engine side).

NOTE: Make sure that throttle cable does not hold throttle slide. Loosen cable adjuster accordingly.

Section 04 FUEL SYSTEM
Subsection 02 (CARBURETORS, THROTTLE AND CHOKE CABLES)

ENGINE	THROTTLE SLIDE HEIGHT (drill bit size) ± 0.1 mm (± .004 in)
377 engine	1.7 (.067)
552 engine except in Summit	1.6 (.063)
552 engine in Summit	1.9 (.075)

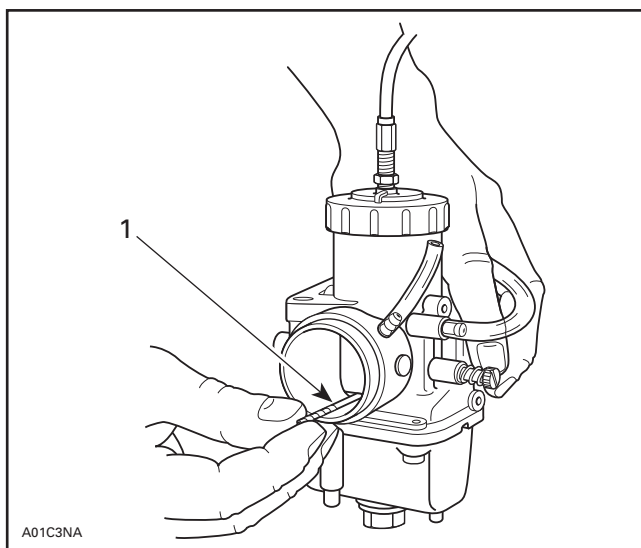

TYPICAL
1. Drill bit used as gauge for throttle slide height

Final idle speed adjustment (engine running at idle speed) should be within 1/2 turn of idle speed screw from preliminary adjustment.

NOTE: Remaining carburetor adjustments are performed once carburetor is installed in vehicle. Refer to INSTALLATION BELOW.

INSTALLATION

CAUTION: Never allow throttle slide(s) to snap shut.

Prior to installing carburetor, adjust air screw and preliminary idle speed as described above.

To install carburetor on engine, inverse removal procedure.

However, pay attention to the following:

On applicable models, make sure to align tab of carburetor with notch of intake adapter.

CAUTION: The rubber intake adapter must be checked for cracks and/or damage. At assembly, the intake adapter must be perfectly matched with carburetor and engine otherwise severe engine damage will occur.

Carburetor Synchronization

When depressing throttle lever, both carburetor slides must start to open at same time.

Unlock cable adjustment lock nut on one carburetor. Screw or unscrew cable adjuster until all carburetor slides start to open at same time. Cable play will be identical on all carburetors. Retighten jam nut.

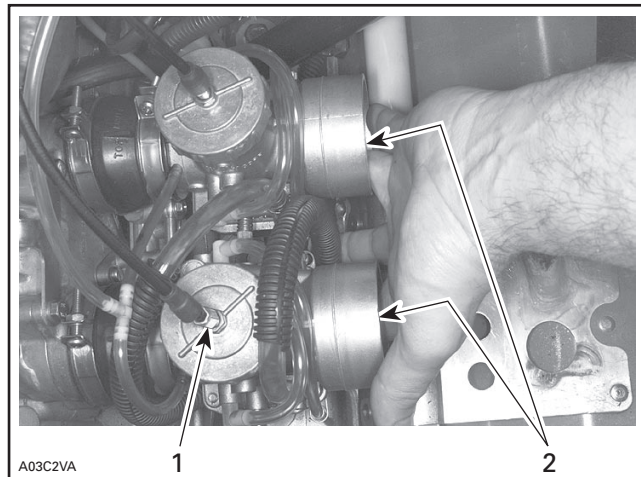

TYPICAL
1. Screw or unscrew adjuster
2. Check that all slides start to open at the same time

Check throttle slide position at wide open throttle. Throttle slide must be flush or 1.0 mm (.040 in) lower than carburetor outlet bore. At that same position, check that throttle slide does not contact carburetor cover. Turn cable adjuster and recheck synchronization.

CAUTION: If the throttle slide rests against the carburetor cover at full throttle opening, this will create too much strain and may damage the throttle cable or other components in throttle mechanism.

CAUTION: Make sure all carburetors start to operate simultaneously.

Section 04 FUEL SYSTEM

Subsection 02 (CARBURETORS, THROTTLE AND CHOKE CABLES)

Idle Speed Adjustment

CAUTION: Before starting engine for the final idle adjustment, make sure that oil pump is adjusted. The oil injection pump adjustment must be checked after each time carburetor idle is adjusted. Refer to OIL INJECTION SYSTEM.

Start engine and allow it to warm then adjust idle speed to specifications by turning **idle speed** screw clockwise to increase engine speed or counterclockwise to decrease it.

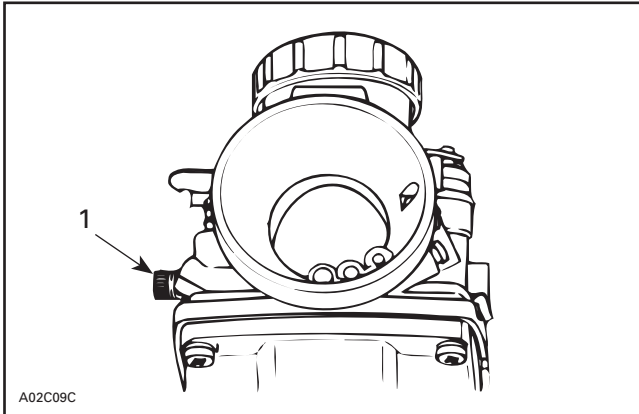

1. Idle speed screw

ENGINE	IDLE SPEED (RPM)
377 and 552	1650

NOTE: Turn adjustment screw the same amount on each carburetor to keep carburetors synchronized.

CAUTION: Do not attempt to set the idle speed by using the air screw. Severe engine damage can occur.

CHOKE

Choke Plunger Adjustment

Set choke lever to half open position.

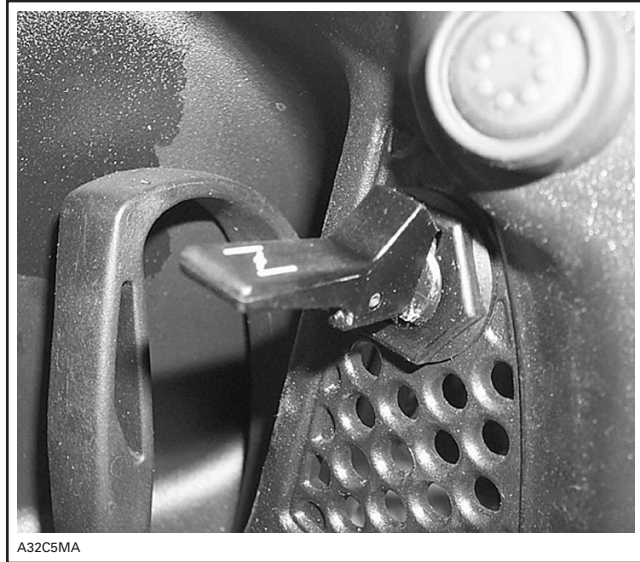

A32C5MA

TYPICAL — CHOKE LEVER — HALF OPEN POSITION

Use choke plunger tool (P/N 529 035 602).

Insert the choke plunger tool into choke air inlet of carburetor. Tool stopper may not lean against recess wall.

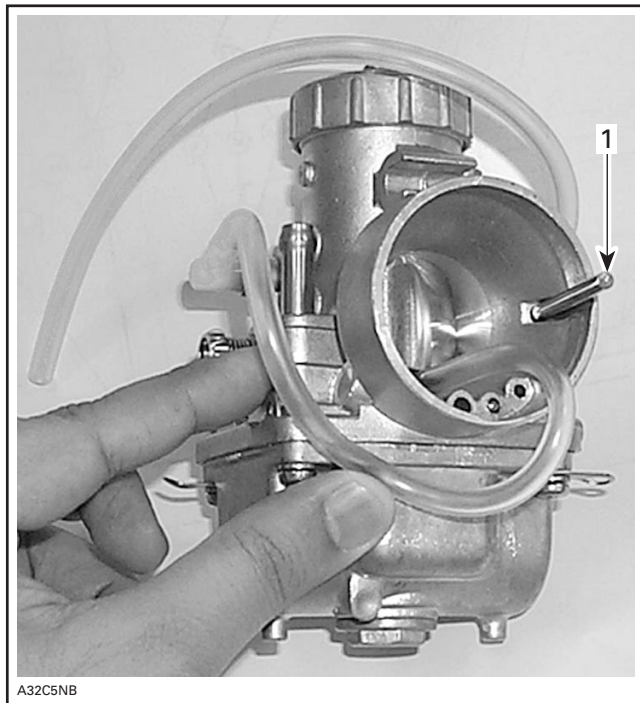

A32C5NB

AIR SILENCER SIDE SHOWN

1. Choke plunger tool

Section 04 FUEL SYSTEM
Subsection 02 (CARBURETORS, THROTTLE AND CHOKE CABLES)

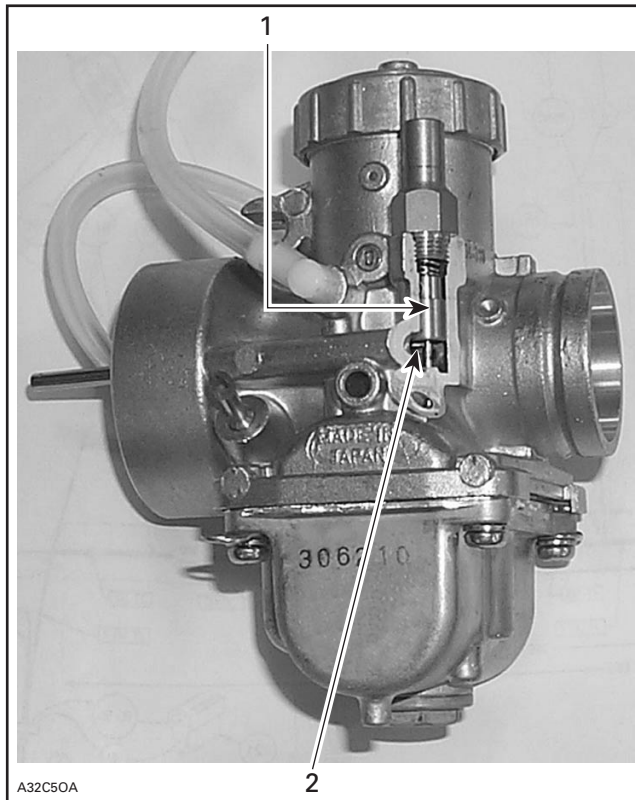

CUT-AWAY (ENGINE SIDE SHOWN)

1. Choke plunger
2. Tool properly seated under choke plunger

If tool tip does not seat under choke plunger **no. 12**, adjust as follows:

Make sure choke lever is at half open position.

Turn choke cable adjustment nut by hand until tool properly seats under choke plunger.

NOTE: A light pressure should be needed to position tool under plunger.

Tighten choke cable lock nut and reinstall protector cap.

Set choke lever to close and open positions and ensure that tool properly seats under plunger **only** when lever is set to half open position.

Set choke lever to close position and, by pulling and pushing choke lever, make sure there is no tension on cable (free play).

Section 04 FUEL SYSTEM

Subsection 02 (CARBURETORS, THROTTLE AND CHOKE CABLES)

CARBURETOR TM TYPE

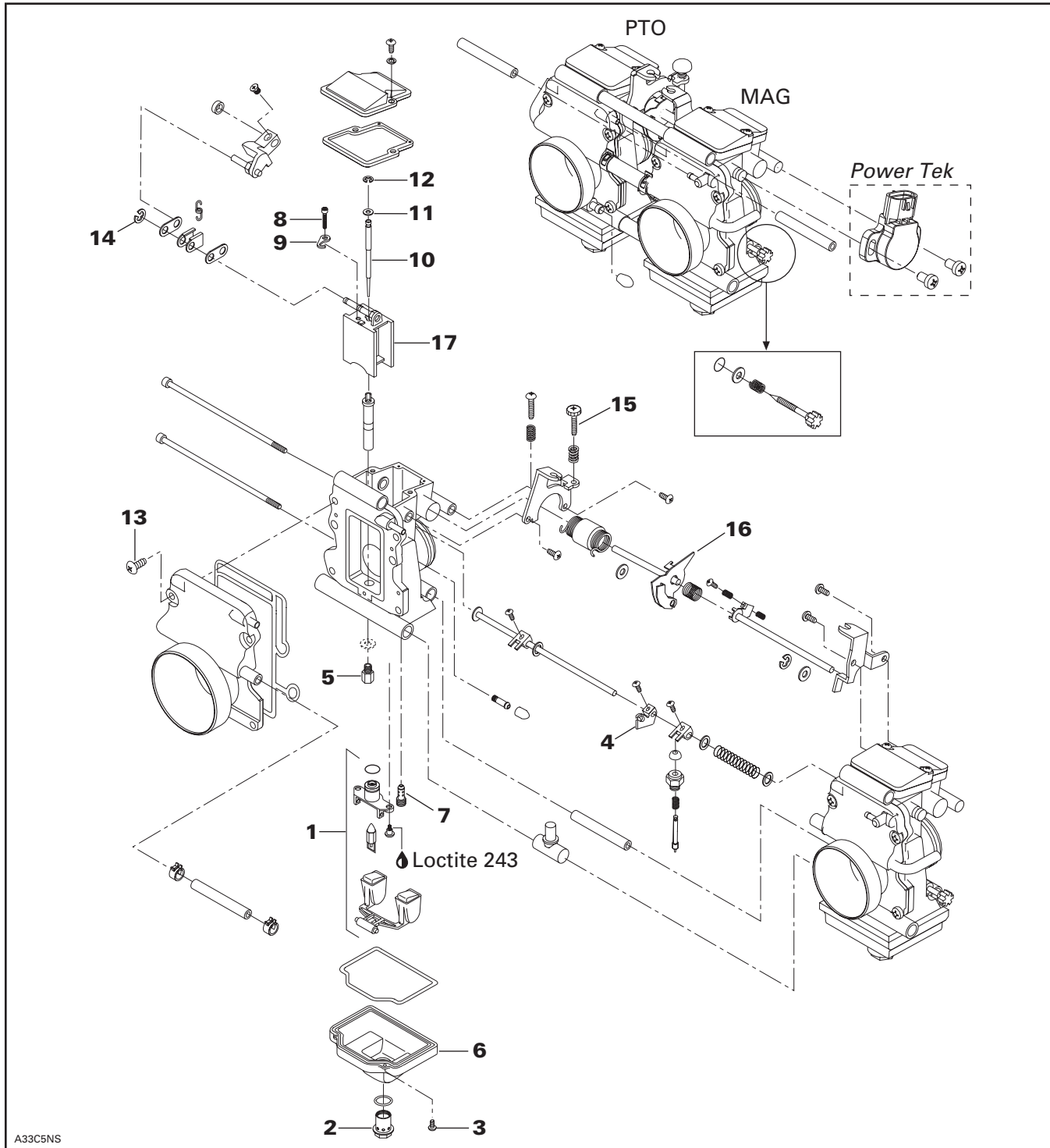

A33C5NS

IDENTIFICATION

TM type dual carburetor ass'y is identified on PTO side carburetor body.

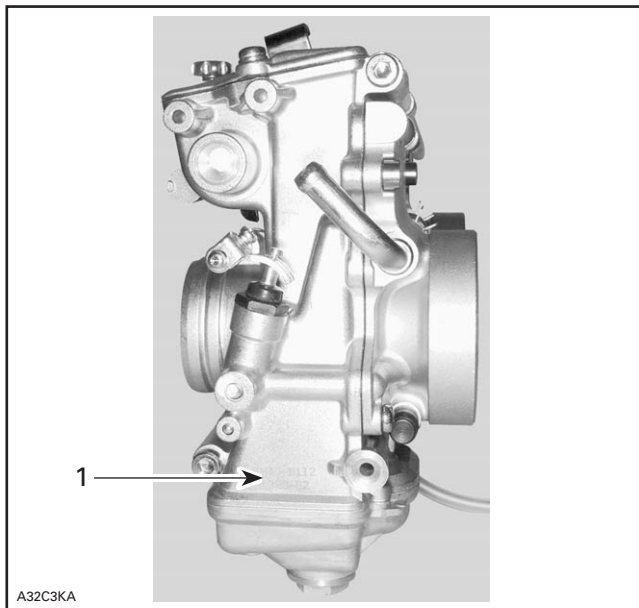

TYPICAL

1. Identification: TM 40-B112

REMOVAL

Throttle Position Sensor (TPS)

793 HO Power Tek Engine Only

For replacement procedure, refer to COMPONENT INSPECTION, REPLACEMENT AND ADJUSTMENT in ENGINE MANAGEMENT (Power Tek).

Throttle/Oil Pump Cable

NOTE: Before removing the cable from vehicle, note its routing for installation.

Using long nose pliers to hold the cable, push the end of cable out of its location.

Remove the retaining circlip.

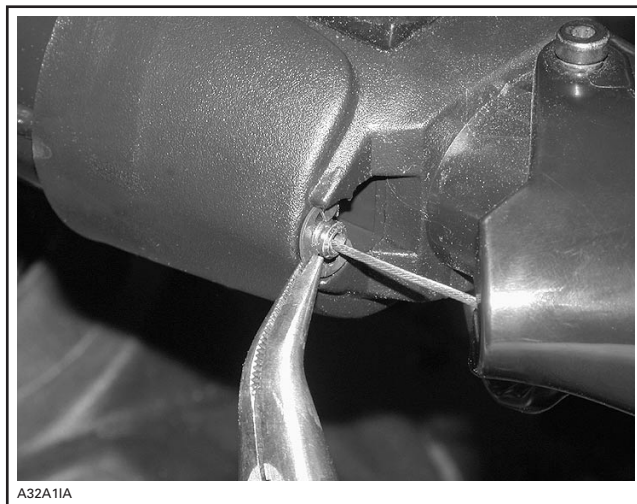

TYPICAL

Remove the handle cover.

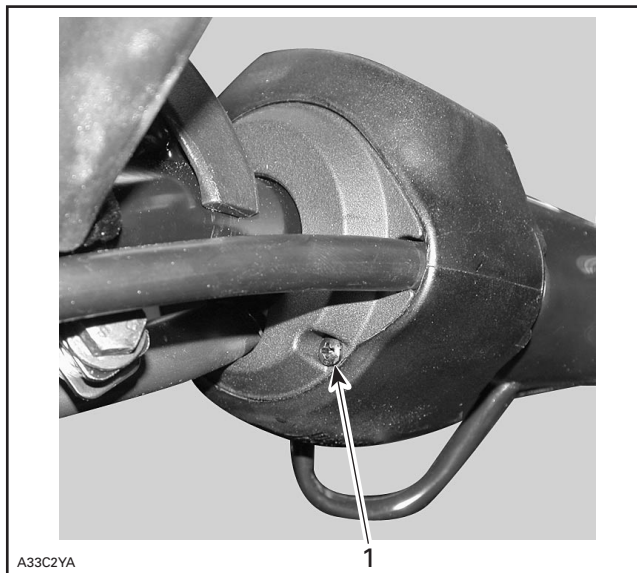

1. Handle cover screw

Unhook the cable sheath then remove the cable from handle.

Remove air intake silencer.

Disconnect the cable end from carburetors or throttle body.

Disconnect cable end from oil pump.

NOTE: The carburetors or the throttle body can be removed to allow an easier access to the oil pump.

Carburetors

Lift hood and open LH side panel.

Section 04 FUEL SYSTEM

Subsection 02 (CARBURETORS, THROTTLE AND CHOKE CABLES)

DPM Models

Disconnect air temperature sensor connector at air intake silencer.

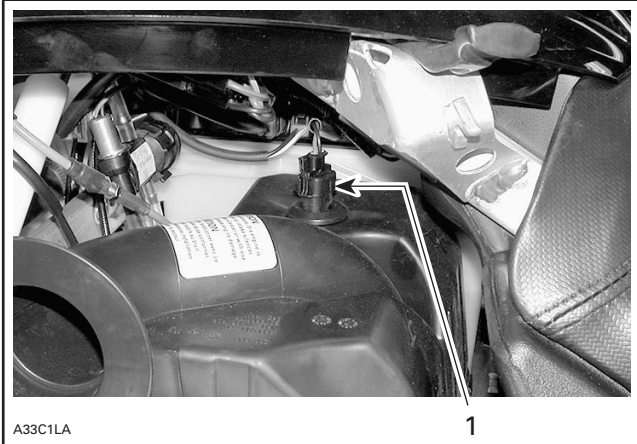

1. Disconnect

All Models

Loosen clamps retaining air intake silencer adapter to carburetors and remove air intake silencer.

DPM Models

Unhook DPM manifold from its support.

Disconnect carburetor vent hose from DPM manifold.

Disconnect TPS connector at carburetor (Power Tek models).

Non-DPM Models

Disconnect carburetor float bowl vent hose.

All Models

Close valve at heated carburetor coolant inlet line.

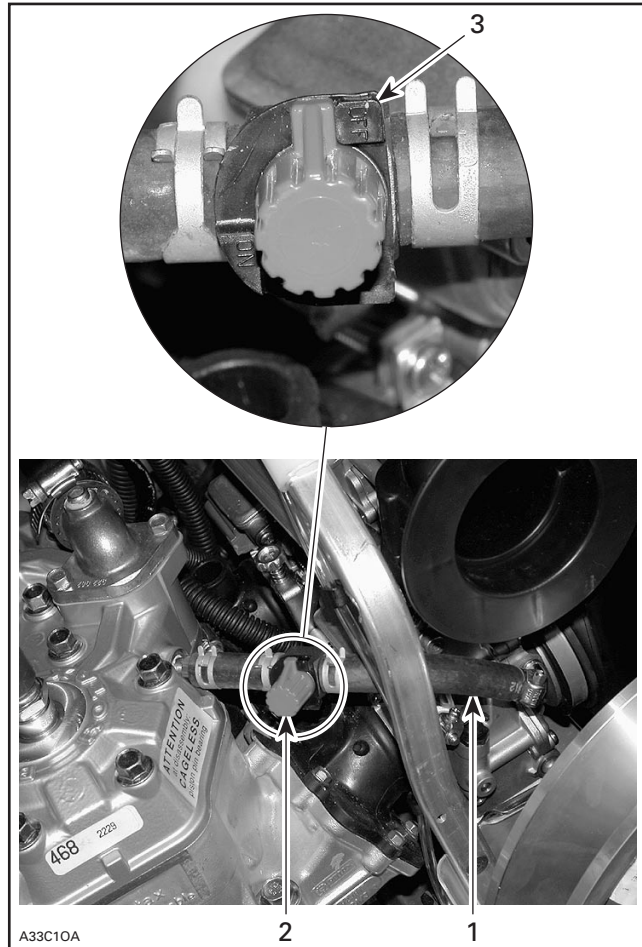

1. Inlet line
2. Valve
3. OFF

Disconnect heated carburetor coolant inlet line taking care to recuperate coolant.

Disconnect throttle and choke cables.

Loosen clamps retaining carburetors to intake adapters.

Remove carburetors, pinch and disconnect fuel line. Take care to recuperate fuel in a proper container.

WARNING

Fuel is flammable and explosive under certain conditions. Always wipe off any fuel or oil spillage from the vehicle. Ensure work area is well ventilated. Do not smoke or allow open flames or sparks in the vicinity.

Pinch heated carburetor coolant outlet line.

Section 04 FUEL SYSTEM

Subsection 02 (CARBURETORS, THROTTLE AND CHOKE CABLES)

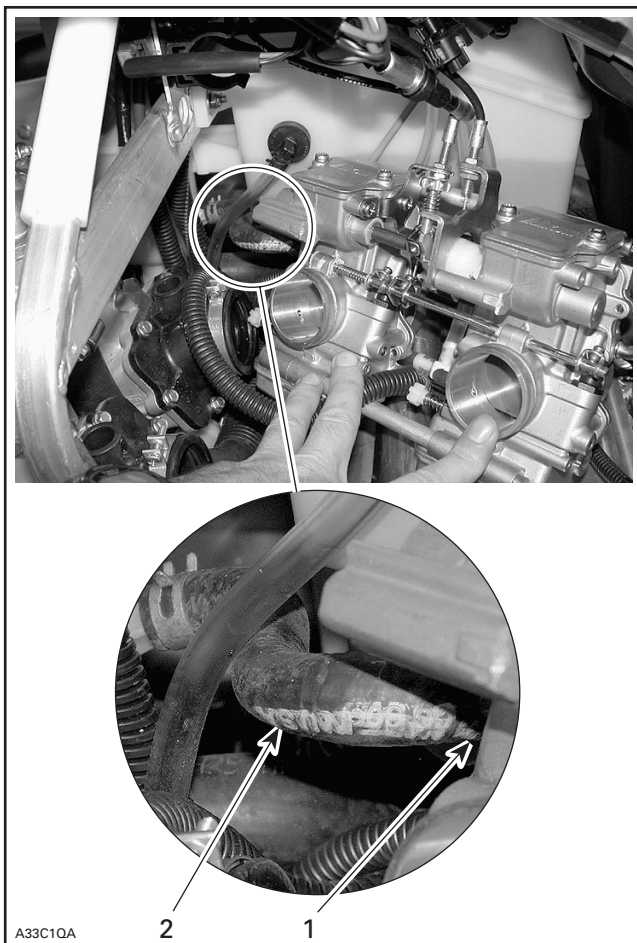

1. Outlet line
2. Pinch here

Disconnect **outlet** line from carburetor assembly taking care to recuperate coolant.

CLEANING AND INSPECTION

The entire carburetor should be cleaned with a general solvent and dried with compressed air before disassembly.

CAUTION: Heavy duty carburetor cleaner may be harmful to the float material and to the rubber parts, O-rings, etc. Therefore, it is recommended to remove those parts prior to cleaning.

Carburetor body and jets should be cleaned in a carburetor cleaner following manufacturer's instructions. When jets are very dirty or coated with varnish and gum, replace them.

⚠ WARNING

Solvent with a low flash point such as gasoline, naphtha, benzol, etc., should not be used as they are flammable and explosive.

Check throttle slide for wear. Replace as necessary.

Check for fuel soaked into float **no. 1**; replace as necessary.

Check float for cracks or other damages affecting free movement; replace as necessary.

Inspect throttle and choke cables and housings for any damage. Replace as necessary.

DISASSEMBLY AND ASSEMBLY

NOTE: To ease the carburetor disassembly and assembly procedures, it is recommended to use carburetor tool kit (P/N 404 112 000).

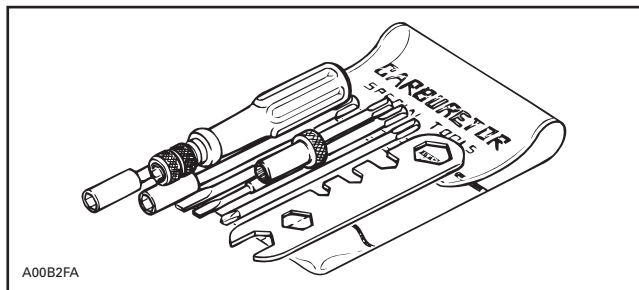

Float Bowl

Unscrew drain plug **no. 2** and screw **no. 3**. Remove float bowl **no. 6**.

Float and Needle Valve Assembly

Unfasten both screws then, pull out float and needle valve assembly.

At assembly, apply Loctite 243 on screw threads.

Main Jet

The main jet **no. 5** installed in the carburetor has been selected for a temperature of -20°C (0°F) at sea level (except Power Tek models, refer to ENGINE MANAGEMENT). Different jetting can be installed to suit temperature and/or altitude changes. A service bulletin gives information about calibration according to altitude and temperature.

Main jet **no. 5** may be removed without removing float bowl **no. 6** by first removing drain plug **no. 2**.

Section 04 FUEL SYSTEM

Subsection 02 (CARBURETORS, THROTTLE AND CHOKE CABLES)

Pilot Jet

Use narrow screwdriver from carburetor tool kit (P/N 404 112 000) to unscrew pilot jet no. 7.

Throttle Slide

WARNING

It is critical to the free operation of the throttle slide that the 2 connecting plates as assembled in one carburetor be of the exact same length. Always replace the connecting plates by a pair of new ones that were matched at the factory for length and discard the old ones. Simultaneously replace all the plates of the carburetors of a same rack.

Do not disassemble throttle slide no. 17 needlessly.

CAUTION: After throttle slide reassembly, proceed with a leak test. See below for procedure.

Disassemble both carburetors at the same time. Coolant hose between carburetor throttle slide covers must remain in place during the complete disassembly and assembly.

Remove carburetor cover.

Loosen needle retainer screw no. 8.

Fully open throttle and hold in this position for the following step.

Move aside needle retainer no. 9.

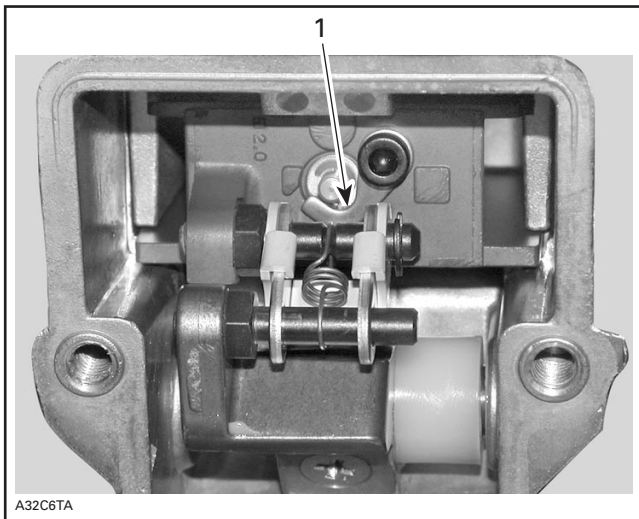

1. Needle retainer moved aside

Turn dual carburetor assembly upside down to free needle no. 10. Take care not to lose plastic washer no. 11 under needle circlip no. 12.

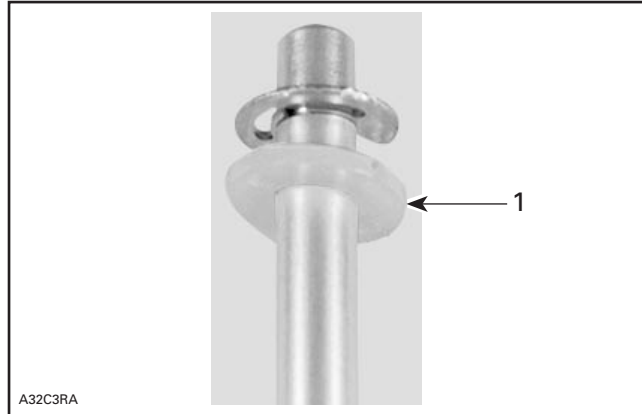

1. Plastic washer

Unscrew throttle slide cover screws no. 13.

Open throttle 3/4 wide and keep that opening.

Lift throttle slide covers bottom first until they are free from carburetor bodies. Then, slide them out.

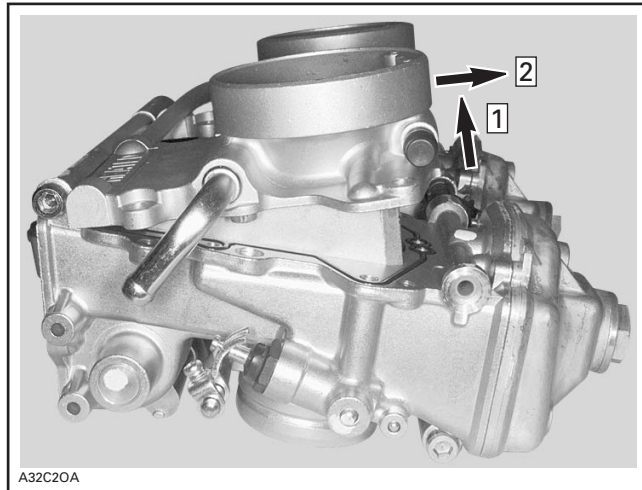

1. Lift bottom first
2. Slide out

Remove circlip no. 14 retaining throttle slide.

Section 04 FUEL SYSTEM

Subsection 02 (CARBURETORS, THROTTLE AND CHOKE CABLES)

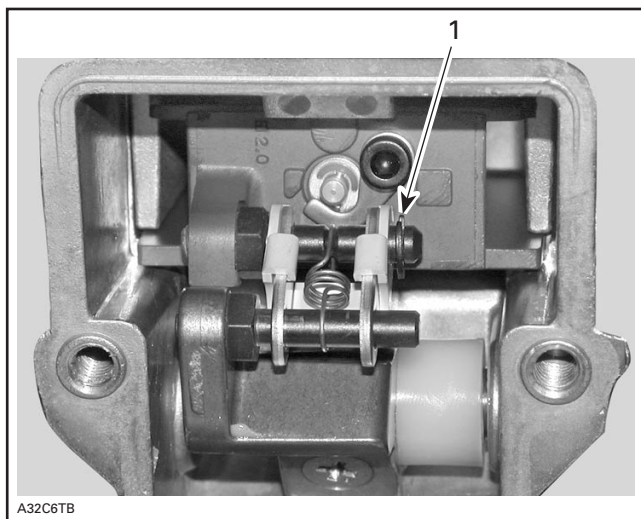

1. Circlip

At throttle slide assembly, needle retainer must face carburetor body.

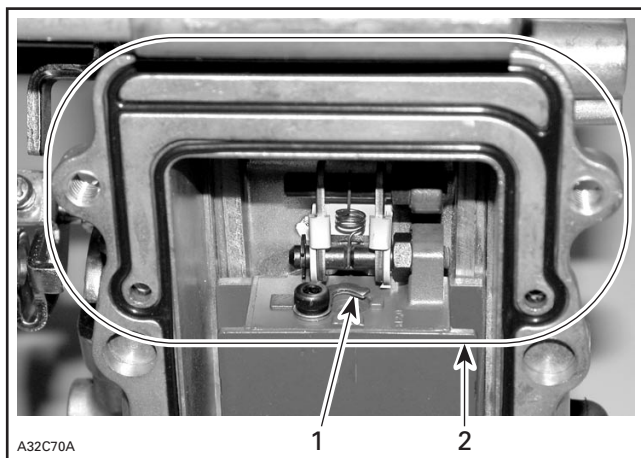

1. Needle retainer
2. Ensure O-ring gasket is properly seated in nipple area

After inserting throttle slide cover in place and before installing screws, ensure O-ring gasket is properly seated in its groove especially in the area around vent nipple. See illustration above.

INSTALLATION

Throttle/Oil Pump Cable

For installation, reverse the removal procedure.

To adjust throttle and oil pump cables see further in this section.

Carburetors

CAUTION: Never allow throttle slide(s) to snap shut.

Install throttle cable to cam lever no. 16.

Install choke cable to cam lever no. 4.

Install dual carburetor assembly.

Make sure dual carburetor assembly is properly inserted into intake adapters, hold it in place and tighten retaining clamps.

Secure heated carburetor inlet and outlet lines with clamps, tighten to 1.5 to 2.0 N•m (13 to 18 lbf•in) and remove pincher on outlet line.

Allow coolant to flow from coolant tank to carburetor before opening valve.

Connect all hoses to dual carburetor assembly and to DPM (if applicable), making sure there are no kinked hoses after reconnection.

Reconnect TPS connector (Power Tek models).

Reinstall air intake silencer.

Make sure dual carburetor assembly properly slides into air intake silencer adapters; hold it in place and tighten clamps.

Non-DPM Models

Reconnect carburetor vent hose.

DPM Models

Reinstall DPM manifold in its support.

Reconnect air temperature sensor connector to air intake silencer.

CARBURETOR ADJUSTMENTS

Adjustments should be performed following this sequence:

- pilot screw adjustment
- carburetor synchronization and throttle slide height (preliminary idle speed adjustment)
- throttle cable adjustment
- TPS reset (Power Tek engine)
- idle speed adjustment (engine warmed up, all components installed).

Section 04 FUEL SYSTEM

Subsection 02 (CARBURETORS, THROTTLE AND CHOKE CABLES)

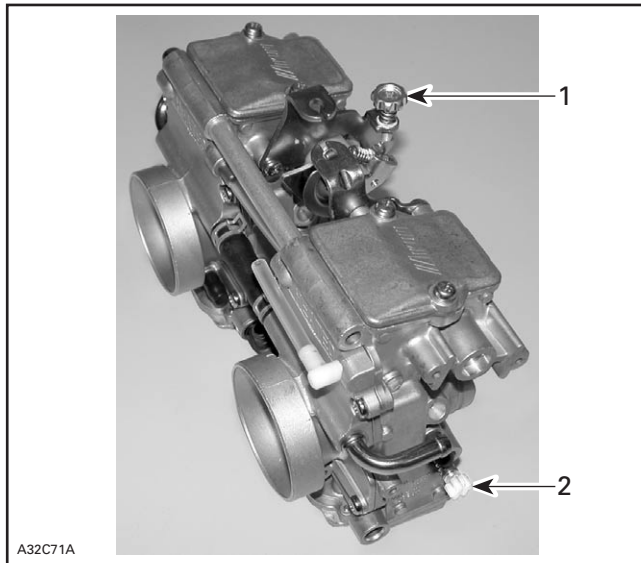

1. Idle speed screw
2. Pilot screw (one on each carburetor)

Pilot Screw Adjustment

Completely close the pilot screw (until a slight seating resistance is felt) then back off as specified.

Turning screw in clockwise leans mixture and conversely, turning it out counterclockwise enriches mixture.

ENGINE	TURNS
All	1.5

Carburetor Synchronization and Throttle Slide Height (preliminary idle speed adjustment)

First proceed on PTO carburetor.

Use a drill bit to measure throttle slide height (see following table) on **outlet** side of carburetor (engine side).

Adjust by turning idle speed screw **no. 15**.

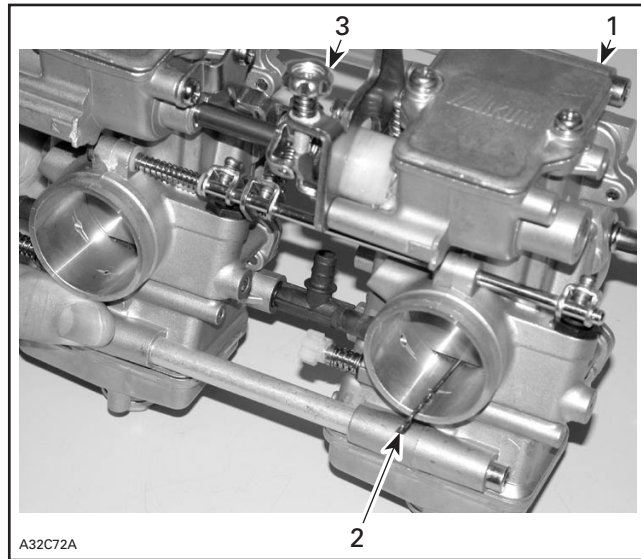

1. Adjust PTO carburetor first
2. Drill bit used as a gauge to measure throttle height
3. Idle speed screw

For MAG carburetor use synchronization screw. Use same drill bit as for PTO carburetor to measure throttle slide height. Turn synchronization screw to adjust.

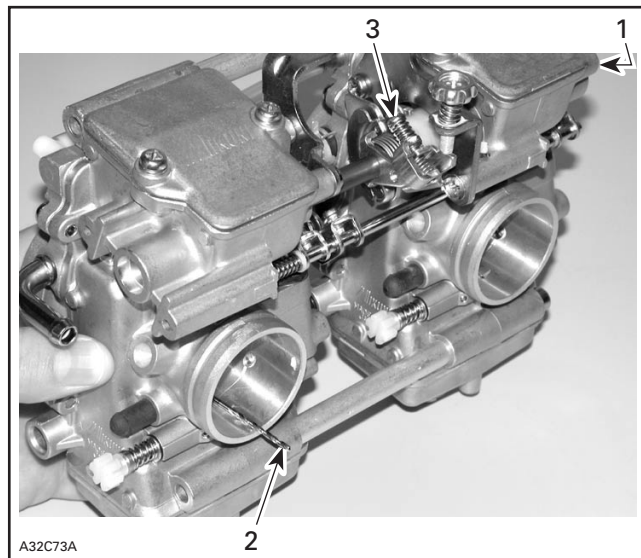

1. PTO carburetor adjusted first
2. Drill bit used as a gauge to measure throttle height
3. Synchronization screw

NOTE: Make sure that throttle cable does not hold throttle slide. Loosen cable adjuster accordingly.

Final idle speed adjustment (engine running at idle speed) should be within 1/2 turn of idle speed screw from preliminary adjustment.

Section 04 FUEL SYSTEM

Subsection 02 (CARBURETORS, THROTTLE AND CHOKE CABLES)

MODELS	THROTTLE SLIDE HEIGHT (drill bit size) ± 0.1 mm ($\pm .004$ in)
593 engine	1.5 (.059)
593 HO engine except in Summit models	1.6 (0.063)
793 HO engines except in Summit Models	1.7 (0.067)
593 HO and 793 HO engines in Summit models	2.0 (.079)

Throttle Cable Adjustment

NOTE: For SDI models, refer to COMPONENT INSPECTION, REPLACEMENT AND ADJUSTMENT in ENGINE MANAGEMENT (SDI).

Adjust throttle cable as per following procedure:

Loosen throttle cable housing adjusting and locking nuts.

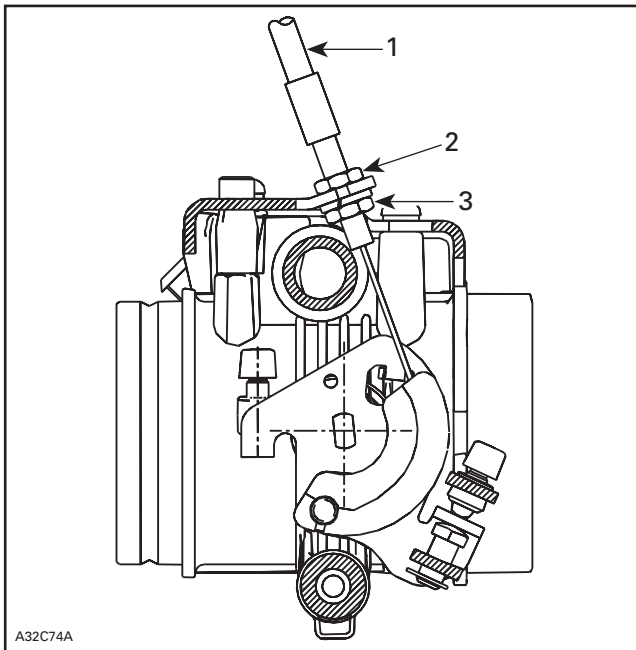

1. Throttle cable
2. Adjusting nut
3. Locking nut

While holding throttle lever to wide open throttle position, adjust throttle cable until cut-away lower edge is equal or 1.0 mm (.04 in) lower than the venturi bore on engine side. In this position, turn cable housing adjusting nut and tighten lock nut.

Also ensure that, when throttle is released to idle position, the idle adjusting screw end touches its stopper. No tension should be applied to throttle cable.

CAUTION: Oil pump cable must be readjusted whenever throttle cable adjustment or idle speed are changed, otherwise serious engine damage may occurs.

793 HO Power Tek Engine

NOTE: On a Power Tek engine, if there is any tension on the throttle cable, it will not be possible to reset the TPS (TPS will be out of range).

Use the VCK (Vehicle Communication Kit) to reset the TPS. For further information, refer to COMPONENT INSPECTION, REPLACEMENT AND ADJUSTMENT in ENGINE MANAGEMENT (Power Tek) section.

CAUTION: Whenever throttle cable is replaced or readjusted, the TPS reset must be performed, otherwise serious engine damaged may occurs.

Idle Speed Adjustment

CAUTION: Before starting engine for the idle adjustment, make sure that oil pump is adjusted. The oil injection pump adjustment must be checked after each time carburetor idle is adjusted. Refer to OIL INJECTION SYSTEM.

Start engine and allow it to warm then adjust idle speed to specifications by turning idle speed screw clockwise to increase engine speed or counterclockwise to decrease it.

ENGINE	IDLE SPEED (RPM)
593 and 593 HO	1600
793 HO	1500

CAUTION: Do not attempt to set the idle speed by using the pilot screw. Severe engine damage can occur.

CHOKE CABLE

Adjustment

Adjust choke cable as per following procedure:

Loosen choke cable housing adjusting and locking nuts.

Section 04 FUEL SYSTEM

Subsection 02 (CARBURETORS, THROTTLE AND CHOKE CABLES)

While choke lever is fully open, pull choke cable until cam lever reaches the stopper. Tighten cable housing adjusting and locking nuts in this position.

As a confirmation, the gap between the stopper and the cam lever should be within 0 and 0.5 mm (0 and 1/64 in).

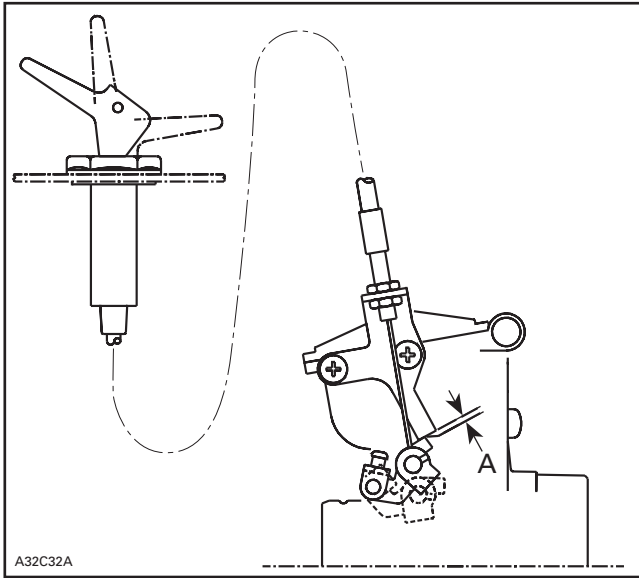

A. Within 0 and 0.5 mm (0 and 1/64 in)

DPM SYSTEM

SERVICE TOOLS

Description	Part Number	Page
Engine leak test kit	529 021 800	196

Section 04 FUEL SYSTEM
Subsection 03 (DPM SYSTEM)

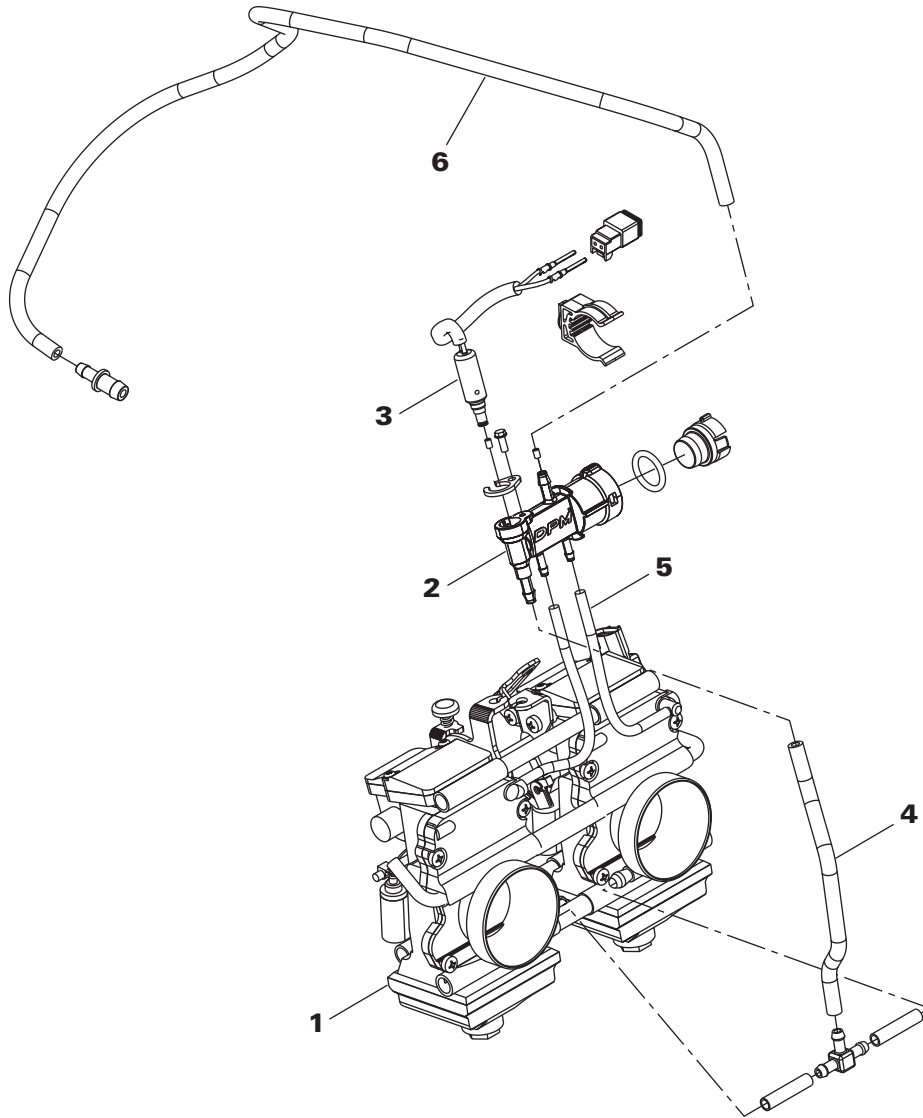

A33C40S

1. TM carburetor
2. DPM manifold
3. DPM solenoid

4. Negative pressure tubes connected to venturi
5. Float bowl tubes
6. Vent tube connected to air intake silencer

OVERVIEW

NOTE: For Power TEK engines, refer to ENGINE MANAGEMENT.

The carburetors are calibrated to operate at -20°C (-4°F), at sea level. Under these conditions the carburetors will properly fulfill engine air/fuel requirements and the DPM is not used. Therefore, the carburetor bowls are under atmospheric pressure and the carburetors work as conventional carburetors.

NOTE: For engine starting and warm-up, the required richer mixture is supplied by a conventional choke (enricher type).

When the temperature and/or altitude increases, then the carburetor jetting becomes inappropriate because engine needs less fuel. The DPM will then decrease the carburetor bowl pressure which in turn, leans the fuel mixture.

The DPM receives negative pressure created in the carburetor venturi. A solenoid (controlled by MPEM) opens the passage, when activated, to decrease the pressure in the carburetor bowls.

SYSTEM TESTING

All DPM Models except Power Tek Engines

NOTE: For Power TEK engines, refer to ENGINE MANAGEMENT.

Air Temperature Sensor

At 20°C (68°F), the sensor resistance must be 2500 Ω ± 300.

Sensor should also be tested through all its operating range. Use the following chart.

Replace sensor if not within specifications.

TEMPERATURE		RESISTANCE (OHMS)
°C	°F	
- 30	- 22	28 000
- 20	- 4	14 500
0	32	5 500
20	68	2 500
40	104	1 200
60	140	600
80	176	320
100	212	180
120	248	120

Solenoid and MPEM

Static Test

Unplug electric connector of solenoid and connect it to a 12 V battery. The solenoid must sound when it opens. Otherwise, replace solenoid. Repeat test several times.

Dynamic Test

Air temperature sensor must be at 20°C (68°F). For the test, operate the engine at the RPM specified in the following chart.

MODEL	TEST RPM
All	3800

The solenoid must vibrate.

Otherwise, ensure fuse(s), wiring harness and connections are in good condition and if so, try a new MPEM and retest. Refer to ELECTRICAL section.

PARTS REMOVAL AND INSTALLATION

All DPM Models

Solenoid

At reassembly, ensure that solenoid seals are in place.

Section 04 FUEL SYSTEM

Subsection 03 (DPM SYSTEM)

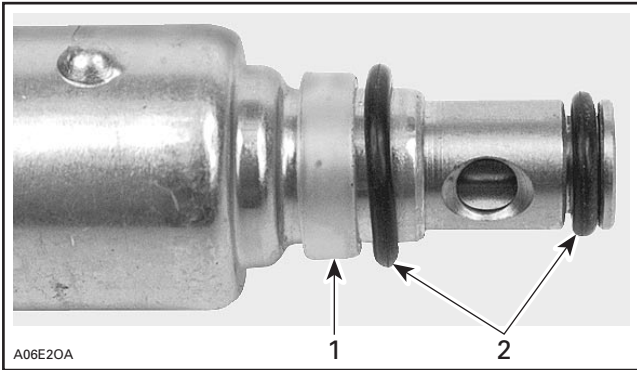

1. Plastic seal
2. O-rings

Jet

When installing jet in DPM, ensure to position the taper end as shown.

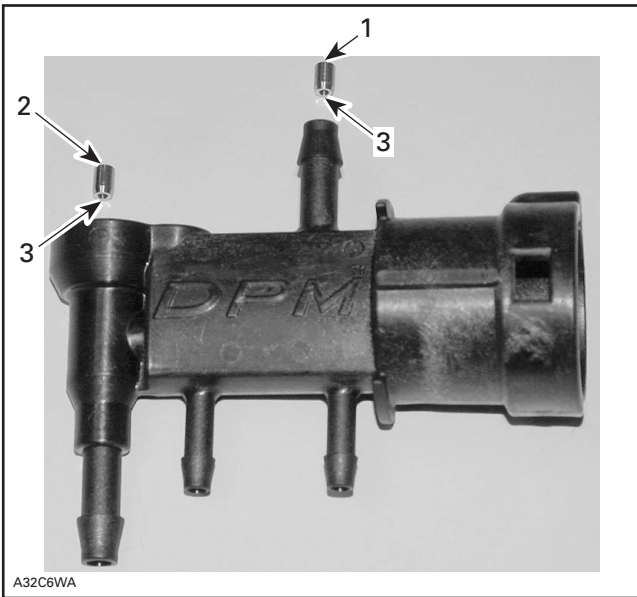

1. Vent jet
2. Lean jet
3. Taper end here

Pay also attention not to mix jets. Refer to the following table for the proper inner diameter size. Refer to the illustration above for the jet location.

MODEL	INSIDE DIAMETER mm (in)	
	VENT JET	LEAN JET
All	1.2 (.047)	2.0 (.079)

Cap

Prior to installing DPM cap, ensure O-ring is in good condition. To install cap, firmly push until tabs click and lock on both sides in DPM.

DPM MANIFOLD TESTING

All DPM Models

Visual Inspection

With DPM manifold removed from vehicle and all hoses disconnected from DPM manifold, inspect for any broken fittings or missing dust caps. If any part is broken, replace DPM manifold and **do not proceed** with leak test procedure. If any part is missing, order necessary part as listed in parts catalog, replace, **then perform leak test procedure**.

If there is no apparent breakage or missing part on DPM manifold, perform the following leak test procedure.

Leak Testing

Required Items

The following items will be required:

- Water column with at least 350 mm (13-3/4 in) in height.
- Engine leak test kit (P/N 529 021 800) .

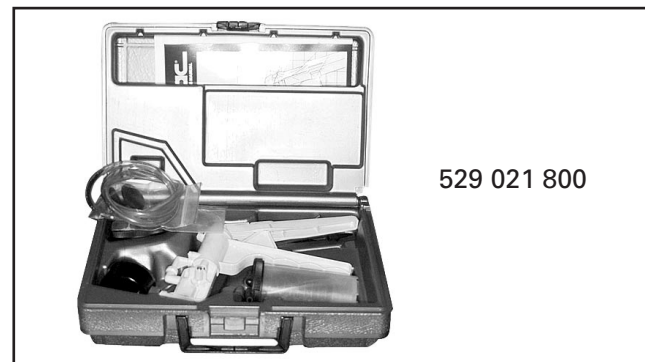

- 4.8 mm (3/16 in) T-fitting.
- 6 mm (15/64 in) T-fitting.
- 3.5 mm (9/64 in) ID x 100 mm (4 in) hose.
- 6 mm (15/64 in) ID x 300 mm (12 in) hose.

DPM Manifold Preparation

Connect hoses as shown.

Section 04 FUEL SYSTEM
Subsection 03 (DPM SYSTEM)

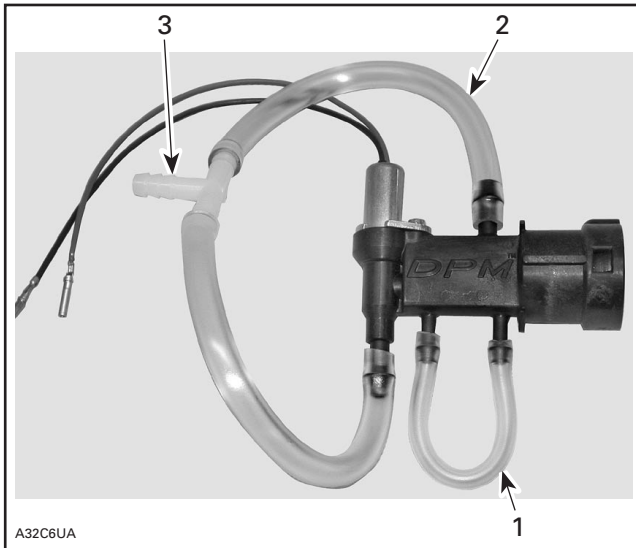

1. 3.5 mm (9/64 in) ID hose
2. 6.0 mm (15/64 in) ID hose
3. 6.0 mm (15/64 in) T-fitting

Water Column Preparation

Mount water column vertically and secure it to a wall or workbench.

Fill water column to center line (at least 175 mm (6-7/8 in)) in height. Refer to following photo.

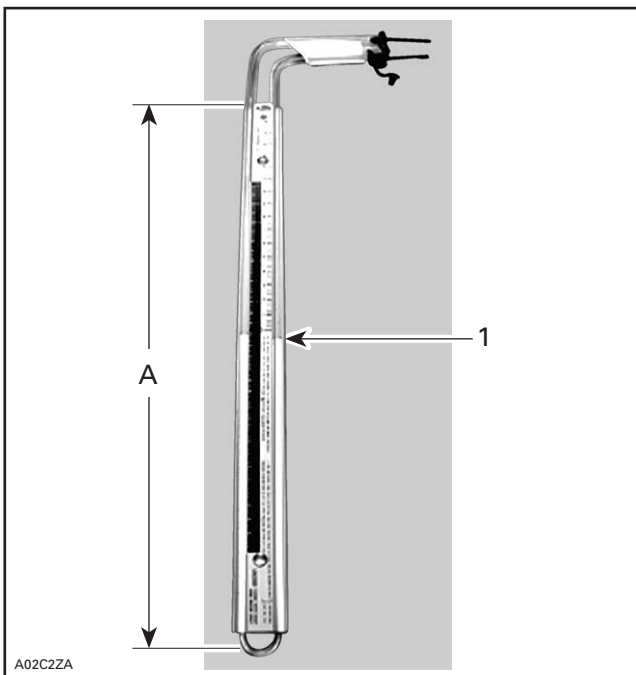

1. Center line at 175 mm (6-7/8 in)
- A. 350 mm (13-3/4 in)

Connecting the Pump, DPM Manifold and Water Column

Connect hoses as shown.

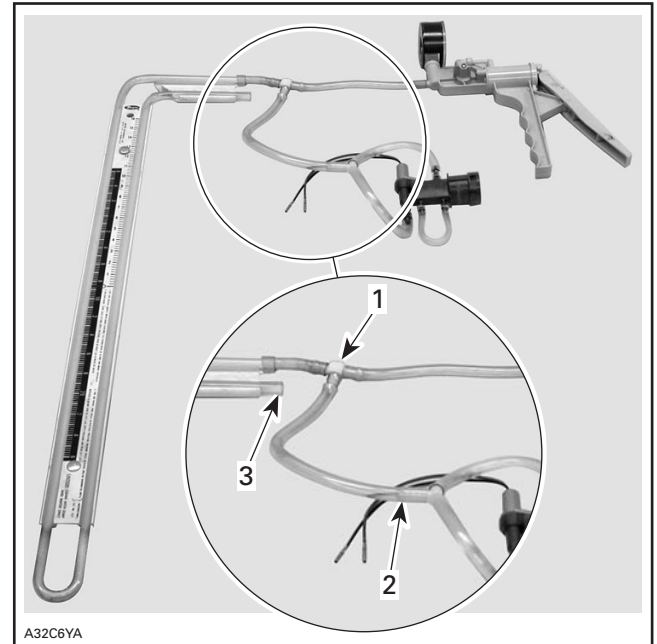

1. 4.8 mm (3/16 in) T-fitting
2. T-fitting
3. Vented to atmosphere

Collect hose into one of the water column tubes, leave the other tube at atmospheric pressure.

Testing

Set pump to «vacuum».

CAUTION: Never use pump directly on DPM to make a pressure test. The vacuum produced by the pump is too high and would damage DPM components. Use the water column as explained above.

Apply negative pressure (vacuum) until the extremities of the water in the tube attain a difference of 350 mm (13-3/4 in).

Stop pumping and allow water levels to stabilize in tube.

Analysis

If water level remains unchanged, the DPM manifold is not defective.

If water level drops slowly to return to an even level in more than 10 seconds, the DPM manifold is not defective.

Section 04 FUEL SYSTEM

Subsection 03 (DPM SYSTEM)

If water level drops to an even level in **less than** 10 seconds, the DPM manifold **is** defective. Replace DPM manifold parts, (refer to *Parts Catalog*) and re-test. If test fails again, replace DPM manifold.

If you are unable to attain any amount of vacuum (water level increases and decreases immediately in tube), check your set-up and re-do the test.

If you still cannot attain any vacuum, DPM manifold **is** defective. Replace DPM manifold.

OVERVIEW

SERVICE TOOLS

Description	Part Number	Page
VCK (Vehicle Communication Kit)	529 035 981	202-203

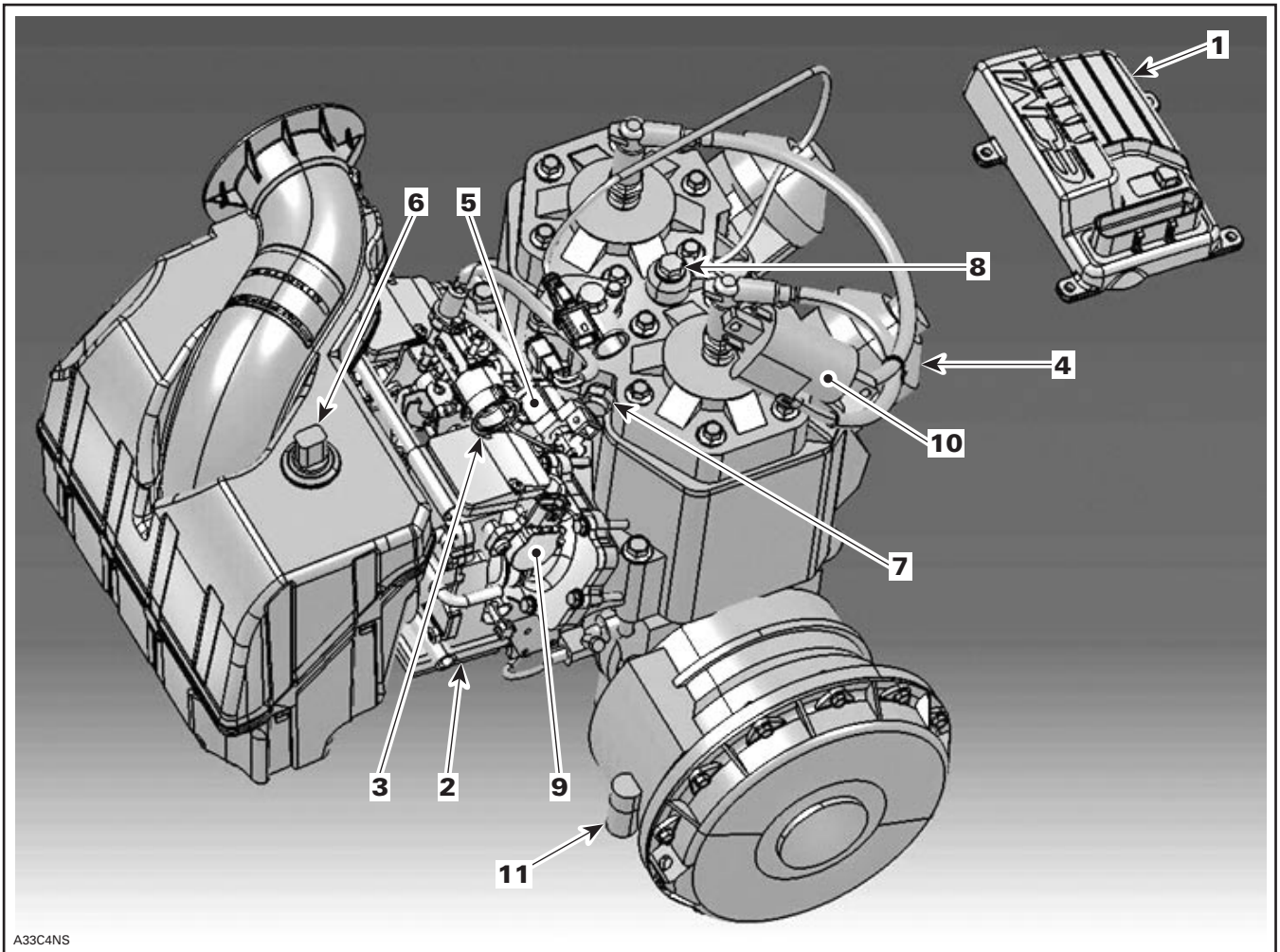

1. Engine control module (ECM) including air pressure sensor (APS)
2. TM carburetors
3. DPM manifold
4. RAVE valves
5. RAVE valve solenoid
6. Air temperature sensor (ATS)
7. Coolant temperature sensor (CTS)
8. Knock sensor (KS)
9. Throttle position sensor (TPS)
10. Ignition coil
11. Trigger coil

Section 05 ENGINE MANAGEMENT (POWER TEK)

Subsection 01 (OVERVIEW)

OPERATING PRINCIPLE

Power TEK

The acronym Power TEK refers to the following technologies found on this engine:

Throttle position sensor
Electronic RAVE
Knock sensor

For this Power TEK 2-stroke engine, a TPS and a knock sensor have been added to provide inputs to the ECM. The engine is equipped with two traditional TM carburetors coupled with the DPM system (Digital Performance Management). The ECM electronically controls the electric RAVE valve solenoid and the DPM solenoid. This achieves an improved fuel economy, a cleaner engine for emission requirements and improved engine protection (against seizure). The use of a TPS along with the trigger coils (engine RPM) allows the ECM to recognize the engine load and thus using 3D DPM and ignition maps. The ECM applies the proper ignition and DPM maps for optimum engine operation in all riding conditions.

FUEL DELIVERY SYSTEM

Fuel Pump

The fuel pump is a conventional diaphragm type that supplies fuel to the carburetors. Refer to FUEL SYSTEM

Carburetors and DPM System

The carburetors are calibrated with the richest jetting required to fulfil the worse operating conditions.

The DPM manifold receives negative pressure created in the carburetor venturi. The DPM solenoid opens the passage from the venturi to decrease the pressure in the carburetor bowls which in turn, lean the fuel mixture.

Using predefined maps, the ECM is constantly activating (duty cycle) the DPM solenoid to optimize the air/fuel mixture.

The ECM receives the signals from different sensors which indicate engine operating conditions at millisecond intervals.

The engine RPM (through the trigger coils) and TPS are the primary sensors used to control the DPM. Other sensors (air pressure, air and coolant temperature) are used as secondary inputs.

As air temperature and altitude change, the ECM uses its 3D mapping to maintain the air/fuel mixture at an optimum.

The ECM begins to lean fuel mixture when engine RPM is above approximately 3500 RPM.

NOTE: For engine starting and warm-up, the required richer mixture is supplied by a conventional choke (enricher type).

For more detailed informations regarding the carburetors and DPM manifold, refer to FUEL SYSTEM section.

ENGINE MANAGEMENT SYSTEM (EMS)

The EMS (Engine Management System) is equipped with an ECM. The ECM is responsible for the following engine management/electrical functions:

- power distribution
- ignition system
- e-RAVE valves
- DESS (Digitally Encoded Security System)
- start/stop functions
- RER (Rotax Electronic Reverse)
- monitoring system
- diagnostic mode
- DPM system

The ECM is the central point of the engine management system. It reads the inputs, makes computations, uses predetermined parameters and sends the proper signals to the outputs for proper engine management.

The ECM also stores the fault codes and general information such as: vehicle hours, serial numbers, customer and maintenance information.

The ECM features a permanent memory that will keep the programmed tether cord cap(s) code, fault codes and other vehicle information, even when the battery is removed from the vehicle on electric start models.

Manual Start Models

At cranking, the magneto sends AC current to the voltage regulator/rectifier that in turn, supplies the ECM with DC current. The ECM then supplies critical functions such as the ignition for engine starting. When engine reaches approximately 800 RPM, the ECM activates the relay that in turn, supplies the electrical loads (lights, accessories etc.).

Electric Start Models

The ECM is directly powered by the battery. When the start switch is activated, it wakes up the ECM which activates the ignition and starting system. When engine reaches approximately 800 RPM, the ECM activates the relay and in turn, it allows current from the voltage regulator/rectifier (supplied by the magneto) to go either to supply the electrical loads (lights, accessories etc.) or to charge the battery through the relay.

EMS — ENGINE MANAGEMENT SYSTEM FUNCTIONS

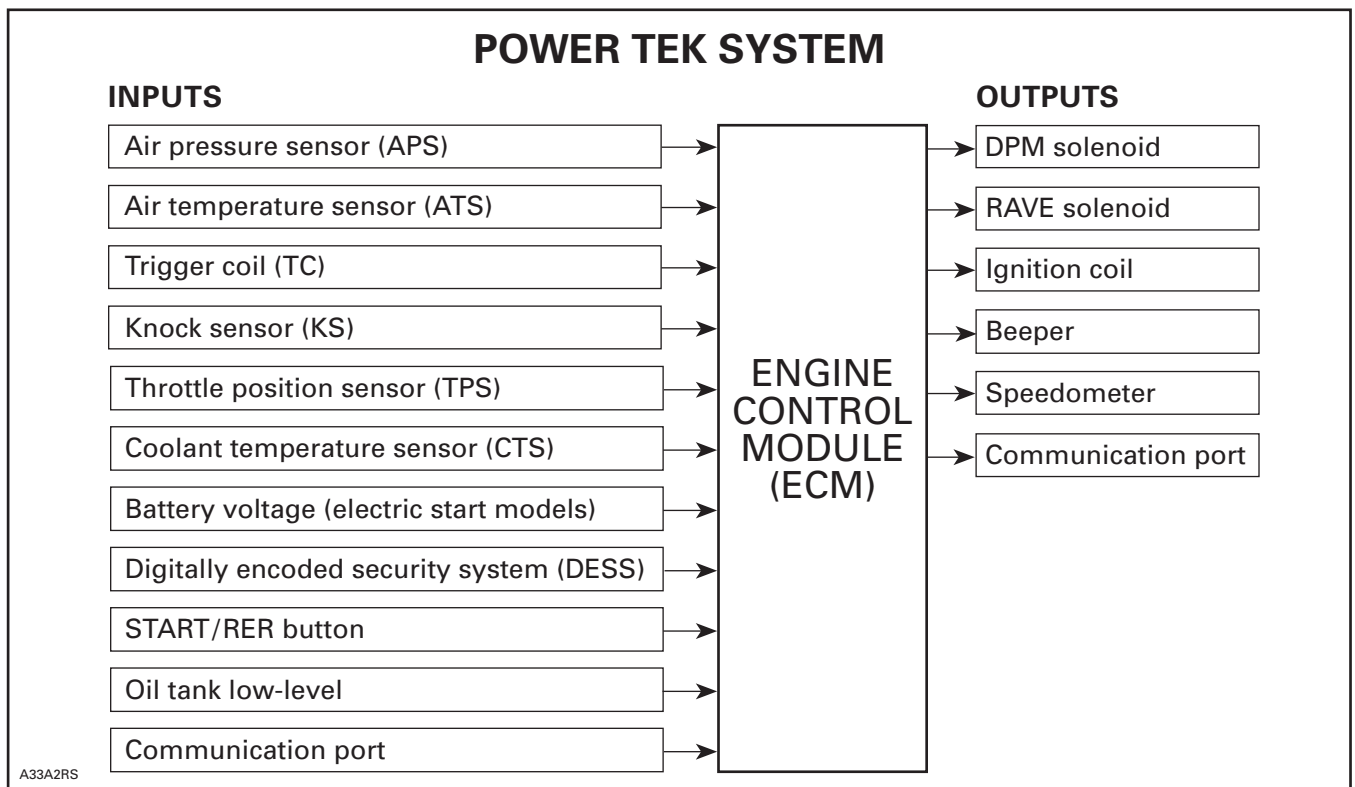

Section 05 ENGINE MANAGEMENT (POWER TEK)

Subsection 01 (OVERVIEW)

POWER DISTRIBUTION

Accessories are protected by fuses. ECM distributes current to low-power devices.

IMPORTANT: Engine-related sensors and actuators are continuously powered when engine runs. **The ECM switches the ground to complete the electrical circuits it controls.** Take this into account when troubleshooting the electrical system.

IGNITION SYSTEM

A CDI ignition system is used. The ECM sends the current to the primary winding of the ignition coil.

Ignition coil induces voltage to a high level in the secondary windings to produce a spark at both spark plugs simultaneously.

Trigger coils are used for:

- 1) Forward engine rotation.
- 2) Reverse engine rotation.
- 3) As a crankshaft position sensor (CPS). This information is sent to the ECM.

The ECM is programmed with data (it contains ignition mappings) for optimum ignition timing under all operating conditions. Using engine operating conditions provided by the sensors, the ECM controls the ignition timing for optimum engine operation.

Knock Sensor

A knock sensor is mounted on top of the cylinder head. It detects specific vibration that would be typically generated by engine detonation.

When knocking occurs, a fault code is generated. Refer to DIAGNOSTIC PROCEDURES.

When knocking occurs, the ECM temporarily retards ignition timing and enriches fuel mixture until knocking disappears. Then, previous parameters automatically resume as required.

Engine RPM Limiter

The ECM will limit the maximum engine speed (approximately 8600 RPM).

ELECTRONICALLY CONTROLLED RAVE

The electronically controlled RAVE (e-RAVE) offers two performance enhancements to conventional RAVE system.

- The opening of the valve is activated electronically. A solenoid holds the valve closed. The ECM monitors throttle position and RPM to operate the solenoid in optimal conditions.
- The valve is opened by crankcase pressure. The greater and more constant pressure from the crankcase opens the valve more crisply.

NOTE: An electric heating element to the RAVE valve solenoid ensures proper function in very cold weather.

Although RAVE valve opening varies according to engine load and RPM, most of the time in usual riding the RAVE valves are held closed up to 50% of throttle opening and 7300 RPM. This gives a quieter engine, better engine efficiency and fuel economy.

DIGITALLY ENCODED SECURITY SYSTEM (DESS)

The following components are specially designed for this system: ECM, tether cord cap and DESS post.

This system allows the engine to reach pulley engagement speed only if a programmed tether cord cap is installed on DESS post. See below for details.

The DESS circuitry is already activated on replacement ECMs.

The tether cord cap contains a magnet and a ROM chip. The magnet actually closes the reed switch inside the post which is the equivalent of a mechanical ON/OFF switch. The chip has a unique digital code.

NOTE: Actually, it is the memory of the ECM which is programmed to recognize the digital code of the tether cord cap. This is achieved with the VCK (Vehicle Communication Kit) (P/N 529 035 981). Refer to its operation manual or help system to program a tether cord cap.

The system is quite flexible. Up to 8 tether cord caps may be programmed in the memory of the ECM. They can also be erased individually.

NOTE: If desired, a tether cord cap can be used on other vehicle equipped with the DESS. It only needs to be programmed for that vehicle.

When starting the engine with a tether cord cap on the post, the DESS is activated and will emit audible signals:

- 2 short beeps indicate a working tether cord cap. Vehicle can be driven.
- 1 short beep indicates a wrong tether cord cap is being used or that something is defective. Vehicle can not be driven.

Engine Starting

If the ECM recognizes a valid tether cord cap, it allows engine to rev above 3000 RPM.

The ECM will shut down immediately after stopping the engine.

ROTAX ELECTRONIC REVERSE (RER)

The ECM recognizes a signal sent by the START/RER switch.

When switch is activated and engine is not running, ECM allows normal engine starting.

When switch is activated and engine is running at idle, the ECM cuts ignition. Therefore, engine RPM gradually drops. When engine reaches a low threshold RPM, the ECM sends an ignition spark at a great advance creating a thrust which reverses engine rotation.

On liquid cooled engines, both trigger coils work all the time.

Under a threshold low RPM or above drive pulley engagement speed, the RER function is disabled. Nothing takes place when pressing Start/RER button.

MONITORING SYSTEM

The ECM monitors the electronic components of the engine and some components of the electrical system.

When a fault occurs, it sends visual messages through the referring LED in speedometer and/or audible signals through a beeper to inform you of a particular condition. Refer to the DIAGNOSTIC PROCEDURES.

Low-Oil Level Warning Device

When the oil falls under a certain level, the low oil level LED will be illuminated.

High Coolant Temperature Warning Device

When the coolant temperature is getting to high, the ECM sends out signals to the beeper and the high temperature LED.

Idle Overheat Protection

If engine overheats when running at idle speed for more than 4 minutes without touching the throttle lever, the beeper will send an audible signal then engine will be automatically stopped.

DIAGNOSTIC MODE

The malfunctions are recorded in the memory of the ECM. The memory of the ECM can be checked using the VCK (Vehicle Communication Kit) (P/N 529 035 981)) to see the fault codes. Refer to the DIAGNOSTIC PROCEDURES.

DIAGNOSTIC PROCEDURES

SERVICE TOOLS

Description	Part Number	Page
12V battery supply cable	529 035 997	210
9V battery supply cable	529 035 675	210
supply harness.....	529 035 869	209
VCK (Vehicle Communication Kit).....	529 035 981	209

GENERAL

Here is the basic order suggested to diagnose a suspected engine management related problem:

- Check the chart in TROUBLESHOOTING section to have an overview of problems and suggested solutions.
- Check if the engine management system (EMS) pilot lamp lights up. If so, use the VCK (Vehicle Communication Kit) and look for fault codes to diagnose the trouble.
- Check all fuses, relay(s) and battery (if so equipped).
- Check spark plugs condition.
- Check all connections of the wiring harness.

Refer to COMPONENT INSPECTION, REPLACEMENT AND ADJUSTMENT section for procedures.

TROUBLESHOOTING

The following chart is provided to help in diagnosing the probable source of simple troubles.

Monitoring Beeper and Light Coded Signals

WARNING SIGNALS				POSSIBLE CAUSE	REMEDY
BEEPER CODE	LED				
	WARNING	DESS/RER	HI-TEMP		
2 short beeps (when engine is started).		Blink		Confirms that proper tether cord cap is installed. NOTE: Engine can rev above clutch engagement.	Normal condition. No problem detected.
2 short beeps every second.				Closed throttle reset was not performed	Perform closed throttle reset.
1 short beep followed by 1 long beep (when engine is running).				Engine overheat at idle NOTE: Engine stops automatically after 4 minutes of idling (without depressing the throttle lever) and engine temperature is higher than 85°C (185°F).	Refer to TROUBLESHOOTING. NOTE: Depressing throttle lever within 4 minutes will reset timer.

Section 05 ENGINE MANAGEMENT (POWER TEK)

Subsection 02 (DIAGNOSTIC PROCEDURES)

WARNING SIGNALS				POSSIBLE CAUSE	REMEDY
BEEPER CODE	LED				
	WARNING	DESS/RER	HI-TEMP		
1 long beep per second.		Blink		Reverse is selected.	Normal condition. No problem detected. Vehicle can be driven in reverse.
1 short beep every 1.5 seconds (when engine is started). NOTE: Engine cannot reach pulley engagement speed. Vehicle cannot be driven.				Bad DESS system connection.	Reinstall tether cord cap correctly over post.
				Defective tether cord.	Use another programmed tether cord cap.
				Dirt or snow in tether cord cap.	Clean tether cord cap.
				Defective DESS post.	Replace DESS post.
Quick beeping.		Blink		Wrong tether cord cap is installed. NOTE: Engine cannot reach pulley engagement speed. Vehicle cannot be driven.	Install proper tether cord cap. Program tether cord into ECM.
2 short beeps every 15 minutes.	Blink		Blink	Engine overheat	Refer to TROUBLESHOOTING.
				EMS fault (1).	Use B.U.D.S. and check fault codes

(1) See EMS Fault code table for more details.

EMS FAULT CODES

General

The faults registered in the ECM (engine control module) are kept when the battery is disconnected.

IMPORTANT: After a problem has been solved, ensure to clear the fault(s) in the ECM using the VCK. This will properly reset their states.

Many fault codes at the same time is likely to be burnt fuse(s).

For more information pertaining to the code faults status and report, refer to B.U.D.S. online help or to the EMS fault code table.

Supplemental Information

When using the service action suggested in the Fault section of B.U.D.S., the system circuits are referred to as DA-41, which means connector on the ECM and the circuit 41.

Fault code P0654

If this code occurs and tachometer works normally, disregard this fault code.

Fault code P0336

This code occurs when engine RPM goes too high which could happen under some mechanical-related circumstances and is not necessarily related to a problem with the engine management system.

Section 05 ENGINE MANAGEMENT (POWER TEK)

Subsection 02 (DIAGNOSTIC PROCEDURES)

Fault code P1102 (TPS "Out of Range" Fault)

It is caused by the sensor reading going out of its allowable range. This fault can occur during the whole range of movement of the throttle.

To diagnose this fully, it is recommended to operate the throttle through its full range. It is also recommended to release the throttle quickly as this may also reveal a fault that is intermittent.

POSSIBLE CAUSES	ACTION
Check if connector is disconnected from TPS	Reconnect.
Check if sensor is loose	Tighten sensor and reset Closed Throttle .
Inspect sensor for damage or corrosion	Replace sensor and reset Closed Throttle .
Inspect wiring (voltage test)	Repair.
Inspect wiring and sensor (resistance test)	If bad wiring, repair. If bad TPS, replace and reset Closed Throttle .
Test sensor operation (wear test)	Replace sensor and reset Closed Throttle .

Fault code P1104 (TPS "Adaptation Failure" Fault)

It is caused by the idle position moving out of an acceptable range.

Following problems can be caused by a TPS "Adaption Failure":

- Idle speed is out of range.
- Engine stops, when throttle is released quickly.
- Engine runs inconsistent in low partload or low RPM.

POSSIBLE CAUSES	ACTION
Sensor has been replaced and TPS closed position not reset	Reset Closed Throttle .
Carburetor has been replaced and TPS closed position not reset	Reset Closed Throttle .
EMS has been replaced and TPS closed position not reset	Reset Closed Throttle .
Throttle cable too tight	Adjust cable and reset Closed Throttle .
Sensor is loose	Tighten sensor and reset Closed Throttle .
Throttle bracket is loose	Fix and reset Closed Throttle .

Section 05 ENGINE MANAGEMENT (POWER TEK)

Subsection 02 (DIAGNOSTIC PROCEDURES)

EMS Fault Code Table

FAULT CODE (P-CODE)	BLINKING LAMP/LED	BEEPER	DESCRIPTION
P0079	Warning light	1 short beep followed by 1 long beep	R.A.V.E.® selenoid open circuit or shorted to ground.
P0080	Warning light	1 short beep followed by 1 long beep	R.A.V.E.® selenoid shorted to battery.
P0107	Warning light	1 short beep followed by 1 long beep	Air pressure sensor voltage too low.
P0108	Warning light	1 short beep followed by 1 long beep	Air pressure sensor voltage too high.
P0112	Warning light	1 short beep followed by 1 long beep	Air temperature sensor voltage too low.
P0113	Warning light	1 short beep followed by 1 long beep	Air temperature sensor voltage too high.
P0117	Warning light	1 short beep followed by 1 long beep	Engine temperature sensor voltage too low.
P0118	Warning light	1 short beep followed by 1 long beep	Engine temperature sensor voltage too high.
P0122	Warning light	1 short beep followed by 1 long beep	Throttle position sensor voltage too low.
P0123	Warning light	1 short beep followed by 1 long beep	Throttle position sensor voltage too high.
P0217	HI-TEMP	1 short beep followed by 1 long beep	High engine temperature detected
P0326	Warning light	1 short beep followed by 1 long beep	Knock sensor reference signal voltage too low.
P0336	None	OFF	High engine RPM detected.
P0513	DESS/RER	3 short beeps every second	Anti-theft security: Invalid key or key not programmed.
P0605	Warning light	1 short beep followed by 1 long beep	ECM Calibration checksum fault.
P0648	None	OFF	DESS lamp shorted to battery, open circuit or shorted to ground.
P0650	None	OFF	Warning light shorted to battery, open circuit or shorted to ground.
P0654	None	OFF	Tachometer RPM signal shorted to battery, open circuit or shorted to ground.
P0655	None	OFF	Engine temperature lamp shorted to battery, open circuit or shorted to ground.
P1102	Warning light	1 short beep followed by 1 long beep	Throttle position sensor learns out of range.
P1104	Warning light	2 short beeps every second	Throttle position sensor offset not programmed.
P1217	HI-TEMP	1 short beep followed by 1 long beep	Overheat shutdown occurred.
P1261	Warning light	1 short beep followed by 1 long beep	DPM selenoid open circuit or shorted to ground.
P1262	Warning light	1 short beep followed by 1 long beep	DPM selenoid shorted to battery.
P1326	Warning light	1 short beep followed by 1 long beep	Engine detonation level too high.
P1655	Warning lamp	1 short beep followed by 1 long beep	DESS® shorted to battery.
P1656	Warning lamp	1 short beep followed by 1 long beep	DESS® line shorted to ground.
P1670	None	OFF	Beeper shorted to battery.
P1671	None	OFF	Beeper open circuit or shorted to ground.
P1675	None	OFF	Relay shorted to battery.
P1676	None	OFF	Relay open circuit or shorted to ground.

VCK (VEHICLE COMMUNICATION KIT)

General

The VCK (Vehicle Communication Kit) (P/N 529 035 981) is the primary tool to diagnose engine management related problems.

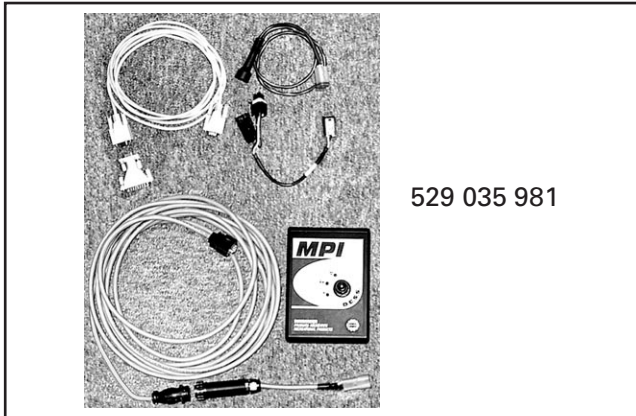

NOTE: The MPEM programmer does not work on Power TEK models.

Ensure to use the latest version of B.U.D.S. available on BOSSWeb.

B.U.D.S. (Bombardier Utility and Diagnostic Software) is designed to allow electrical component inspection, diagnostic options and reset such as the closed throttle.

For more information pertaining to the use of the software B.U.D.S., use its help which contains detailed information on its functions.

⚠ WARNING

If the computer you are using is connected to the power outlet, there is a potential risk of electrocution when working in contact with water. Be careful not to touch water while working with the VCK.

VCK Supply

The VCK (MPI box) can use the vehicle power for its supply. Four AA batteries or an AC/DC power supply can also be used. Make sure to respect MPI specification if a power supply is used.

Connecting VCK to Vehicle

Remove the 6 pin connector from the protective cap on the right side of the vehicle.



Connect supply harness (P/N 529 035 869), to vehicle 6-pin connector.

Connect the 6 pin diagnostic cable from VCK to supply harness.

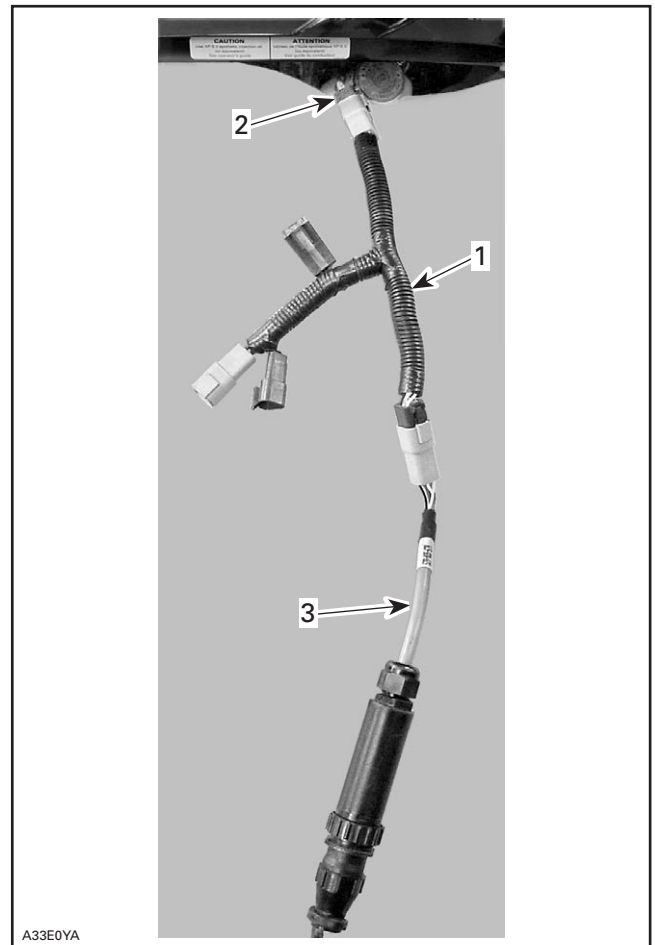

1. Supply harness
2. Vehicle 6-pin connector
3. VCK cable

Section 05 ENGINE MANAGEMENT (POWER TEK)

Subsection 02 (DIAGNOSTIC PROCEDURES)

CAUTION: Connecting VCK directly to vehicle connector (without supply harness) will damage the ECM. Always use the proper supply harness



A33E0ZA

Connect supply harness to a 12V battery, using 12V battery supply cable (P/N 529 035 997); or to a 9V battery, using 9V battery supply cable (P/N 529 035 675).



12V BATTERY SUPPLY CABLE

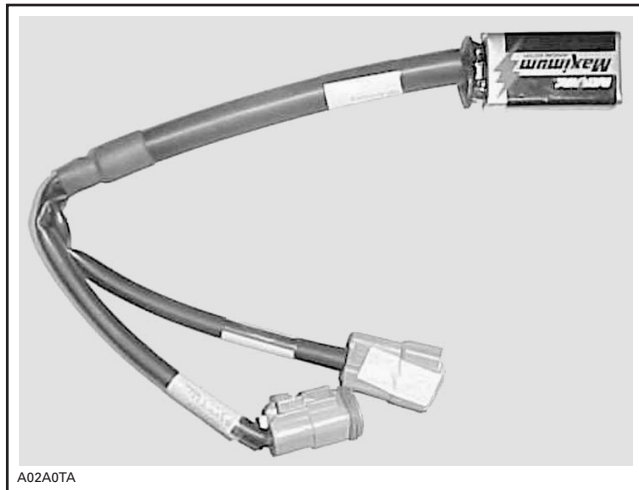

9V BATTERY SUPPLY CABLE

NOTE: The 9V battery allows programming keys, setting ignition timing, reset closed throttle, etc. The 12V battery allows to activate solenoids, spark plugs, etc., from B.U.D.S. Activation tab. In this case, all sensors and actuators will be continuously supplied from the battery. The ECM will switch the circuit to the ground when activated through B.U.D.S. If engine starting is required, disconnect clips from battery.

CAUTION: Always use the proper supply harness and cables. Ensure to respect polarity when connecting cable clips to battery. Match RED cables together.

NOTE

On all models, it is suggested to disconnect headlights fuse to reduce battery discharge rate.

On manual start models, it is necessary to use an external 12V battery and to connect the supply cable clips on it to supply sensors/actuators.

On electric start models, it is necessary to connect the supply cable clips to the battery to supply sensors/actuators.

When using the software B.U.D.S., with the Power TEK:

- ensure that 115200 speed is properly selected in "MPI" under "Choose speed"

Section 05 ENGINE MANAGEMENT (POWER TEK)

Subsection 02 (DIAGNOSTIC PROCEDURES)

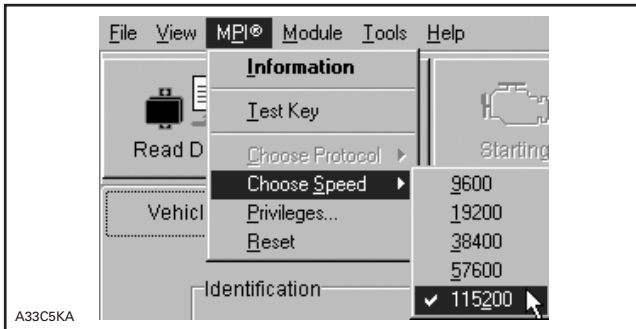

- ensure that the protocol “KW2000” is properly selected in “MPI” under “Choose protocol

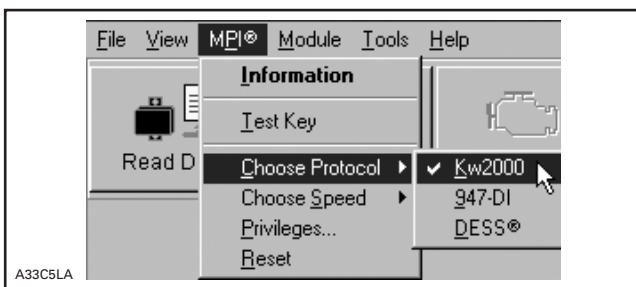

- ensure the status bar shows the KW2000 and the number 1 to the right. To communicate with the ECM, number 1 must be displayed.

Number 1 indicates that the module is recognized by the MPI.

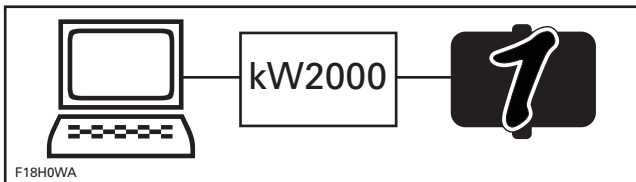

CONNECTION SUCCESSFUL

If an “X” is shown, this means that no communication between the MPI and the ECM is possible. In this case possible causes are:

- ECM is not powered-up
- wrong protocol is used
- bad connection between MPI and module.

When connection is established, a beep pattern will confirm the diagnostic mode is active.

NOTE: Leaving vehicle in diagnostic mode for a long period will discharge battery. Be also aware that some components will generate heat. Always disconnect VCK supply harness and supply cable from vehicle/battery when not working on vehicle.

NOTE: After disconnecting ECM connector for a test and then reconnecting it, it will be necessary to READ data from vehicle again to re-enable B.U.D.S. communication. Otherwise, the following message will occur.

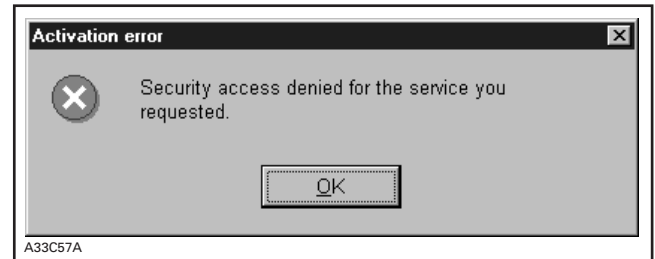

COMPONENT INSPECTION, REPLACEMENT AND ADJUSTMENT

SERVICE TOOLS

Description	Part Number	Page
Fluke 111	529 035 868	213
small hose pinchers	295 000 076	218, 225

GENERAL

Engine problems are not necessarily related to the engine management system.

It is important to ensure that the mechanical integrity of the engine/drive systems are present:

- good transmission system operation
- good engine compression and properly operating mechanical components, no leaks etc.

Check the chart in TROUBLESHOOTING section to have an overview of problems and suggested solutions.

When replacing a component, always check its operation after installation.

ELECTRICAL SYSTEM

It is important to check that the electrical system is functioning properly:

- battery
- fuses
- power relay
- DESS
- ignition (spark)
- ground connections
- wiring connectors.

It is possible that a component seems to operate in static condition but in fact, it is defective. In this case, the best way to solve this problem is to remove the original part and replace it with one which is in good condition.

On electric start models, never use a battery charger to substitute temporarily the battery, as it may cause the ECM (engine control module) to work erratically or not to work at all.

Check related-circuit fuse solidity and condition with an ohmmeter. Visual inspection could lead to false results.

To perform verifications, a good quality multimeter such as Fluke 111 (P/N 529 035 868) should be used.



Pay particular attention to ensure that pins are not out of their connectors or out of shape. The troubleshooting procedures cover problems not resulting from one of these causes.

CAUTION: Ensure all terminals are properly crimped on wires and connector housings are properly fastened.

CAUTION: Check if wiring harness shows any signs of scoring prior to replace the ECM.

Section 05 ENGINE MANAGEMENT (POWER TEK)

Subsection 03 (COMPONENT INSPECTION, REPLACEMENT AND ADJUSTMENT)

Before replacing an ECM, always check electrical connections. Make sure that they are very tight and they make good contact and that they are corrosion-free. Particularly check ECM ground connections. Ensure that contacts are good and clean. A “defective module” could possibly be repaired simply by unplugging and replugging the ECM. The voltage and current might be too weak to go through dirty wire pins. Check carefully if pins show signs of moisture, corrosion or if they look dull. Clean pins properly and then coat them prior to assembling as follows:

NOTE: Do not apply dielectric grease or other lubricant on the ECM connectors.

If the newly replaced ECM works, try the old one and recheck if it works.

Ensure that all electronic components are genuine. Any modification on the wiring harness may lead to generate fault codes or bad operation.

NOTE: For diagnostics purposes, use Vehicle Communication Kit (VCK). See DIAGNOSTIC PROCEDURES for proper connectors/adaptors.

NOTE: After disconnecting ECM connector for a test and then reconnecting it, it will be necessary to READ data from vehicle again to re-enable B.U.D.S. communication. Otherwise, the following message will appear at some point.

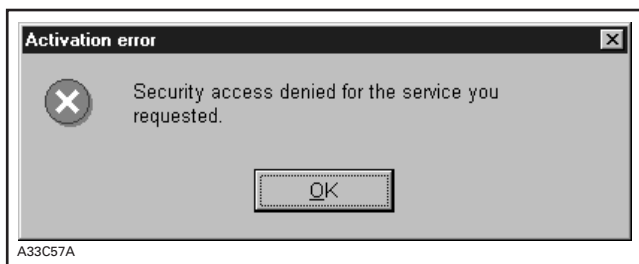

After a problem has been solved, ensure to clear the fault(s) in the ECM using the VCK. Refer to DIAGNOSTIC PROCEDURES subsection.

ECM Connector

Use this diagram to locate the pin numbers on the ECM connector of the wiring harness when performing tests.

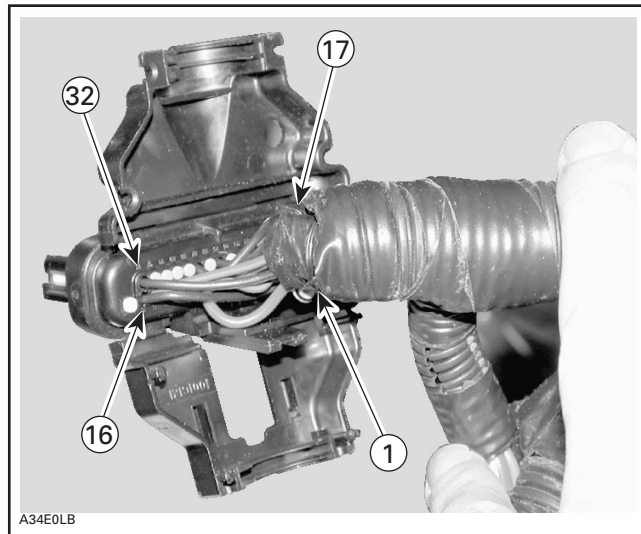

ECM CONNECTOR PIN-OUT (WIRING HARNESS SIDE)

Resistance Measurement

When measuring the resistance with an ohmmeter, all values are given for a temperature of 20°C (68°F). The resistance value of a resistance varies with the temperature. The resistance value for usual resistor or windings (such as solenoid) **increases** as the temperature increases. However, our temperature sensors are NTC types (Negative Temperature Coefficient) and work the opposite which means that the resistance value **decreases** as the temperature increases. Take it into account when measuring at temperatures different from 20°C (68°F). Use this table for resistance variation relative to temperature for temperature sensors.

TEMPERATURE SENSOR TABLE				
TEMPERATURE		RESISTANCE (ohms)		
°C	°F	ATS	CTS FOR	
			GAUGE	ECM
- 40	- 40			72412
- 35	- 31			52637
- 30	- 22	28000		38681
- 25	- 13			28718
- 20	- 4	14500	733.8	21529
- 15	5		587.7	16288
- 10	14		474	12431

Section 05 ENGINE MANAGEMENT (POWER TEK)
Subsection 03 (COMPONENT INSPECTION, REPLACEMENT AND ADJUSTMENT)

TEMPERATURE SENSOR TABLE				
TEMPERATURE		RESISTANCE (ohms)		
°C	°F	ATS	CTS FOR	
			GAUGE	ECM
- 5	23		384.8	9565
0	32	5500	314.3	7418
5	41		258.4	5807
10	50		213.7	4582
15	59		177.7	3644
20	68	2500	148.7	2919
25	77		125	2355
30	86		105.6	1912
35	95		98.69	1562
40	104	1200	76.5	1284
45	113		65.54	1062
50	122		56.38	882.6
55	131		48.72	738.9
60	140	600	42.28	622
65	149		36.82	526.3
70	158		32.19	447.5
75	167		28.24	382.3
80	176	320	24.86	328.1
85	185		21.95	282.8
90	194		19.45	244.8
95	203		17.28	212.8
100	212	180	15.4	185.6
105	221			162.4
110	230			142.7
115	239			125.9
120	248			111.5
125	257			99.02
130	266	90		88.26
135	275			78.93
140	284			70.81

TEMPERATURE SENSOR TABLE				
TEMPERATURE		RESISTANCE (ohms)		
°C	°F	ATS	CTS FOR	
			GAUGE	ECM
145	293			63.71
150	302			57.49

The resistance value of a temperature sensor may test good at a certain temperature but it might be defective at other temperatures. If in doubt, try a new sensor.

Also remember this validates the operation of the sensor at room temperature. It does not validate the over temperature functionality. To test it, the sensor could be removed from the engine/air silencer and heated with a heat gun while it is still connected to the harness to see if the ECM will detect the high temperature condition and generate a fault code.

FUEL SYSTEM

Refer to FUEL SYSTEM as necessary.

Check that the throttle slides move freely and smoothly when depressing throttle lever.

Before replacing any part, check the following as these could be causing the fault. Perform the test while the engine is not running.

- Throttle cable adjustment too tight or there is not enough free-play. Not returning fully to idle stop.
- Throttle idle set screw is loose or worn.
- TPS is loose.
- Corroded or damaged wiring or connectors.
- Throttle cable or carburetor(s) has(ve) been replaced and the **Closed Throttle** reset has not been performed.
- ECM has been replaced and the **Closed Throttle** reset has not been performed.

DPM (Digital Performance Management)

To test DPM manifold, refer to FUEL SYSTEM. The DPM solenoid verification is covered in this section.

Section 05 ENGINE MANAGEMENT (POWER TEK)

Subsection 03 (COMPONENT INSPECTION, REPLACEMENT AND ADJUSTMENT)

ENGINE MANAGEMENT SYSTEM

ENGINE CONTROL MODULE (ECM)

General

Prior to replacing a suspected ECM, ensure that all the recommendations in the general introduction of this section have been followed.

NOTE: All information from the ECM will be lost and will have to be reentered using B.U.D.S. software.

ECM Replacement

Disconnect battery cables on electric start models.

WARNING

Battery BLACK (-) cable must always be disconnected first and connected last.

Disconnect connector from ECM.

Unscrew retaining screws and remove the engine ECM from its support.

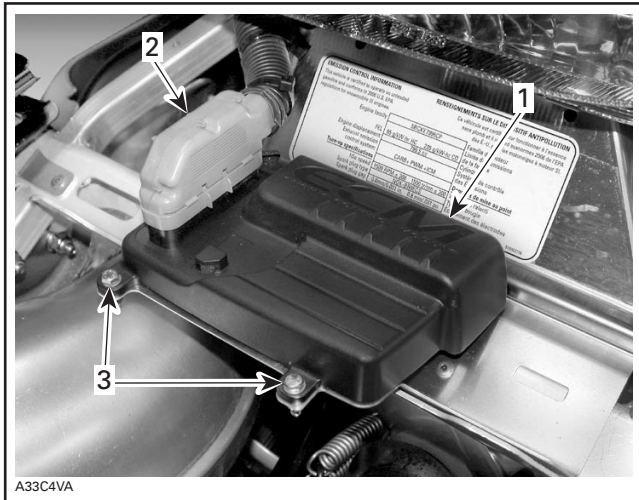

1. ECM
2. ECM connector
3. Retaining screws

Install the new ECM to its support.

Replug ECM connector and then battery cables (if applicable).

Manually enter information in **Vehicle** tab.

IMPORTANT: Pay particular attention when typing the VIN and model numbers. Once **Write Data** button is pressed, numbers cannot be modified.

Reprogram DESS tether cord(s) in **Keys** tab.

Perform **Closed throttle** and **Ignition offset** in **Setting** tab. Refer to appropriate sections.

Start the engine and increase engine speed above 5500 RPM to be sure no fault appears.

POWER RELAY

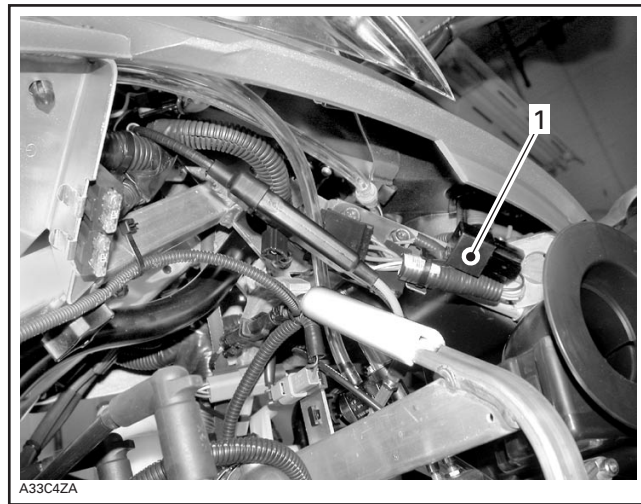

LH SIDE OF VEHICLE

1. Power relay

Connect vehicle communication kit (VCK) and use B.U.D.S. software.

Energize **relay** from **Activation**.

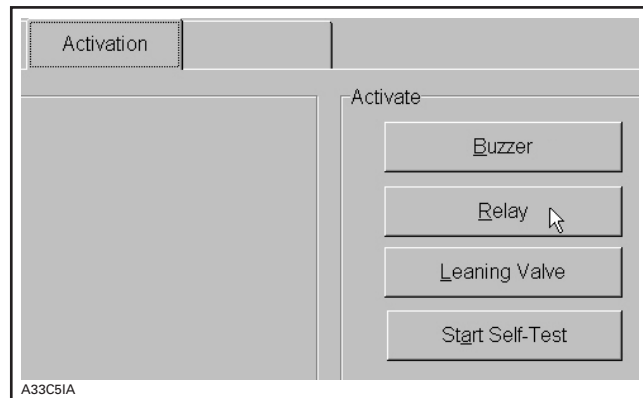

Listen to or touch relay to feel it clicks.

If the relay does not work, disconnect the connector from the relay to test the input side.

Section 05 ENGINE MANAGEMENT (POWER TEK)

Subsection 03 (COMPONENT INSPECTION, REPLACEMENT AND ADJUSTMENT)



LH SIDE OF VEHICLE

1. Relay
2. Power relay connector

Connect a voltmeter between wires as indicated in the following table.

VEHICLES	FROM	TO
	CONNECTOR	
Manual start models	ORANGE/WHITE	Engine ground
Electric start models	WHITE/GREEN	Battery ground

Voltage should be 12 V.

If voltage reads 12 V, check continuity of wire between BLACK wire of relay connector and pin DA-28 of ECM connector. If faulty, repair/replace wire/connector. If wire/connector tests good, try a new ECM.

If voltage does not read 12 V, check continuity of wire on supply side. If faulty, repair/replace wire/connector. If wire/connector tests good, refer to ELECTRICAL SYSTEM to test output side or relay.

THROTTLE POSITION SENSOR (TPS)

General

The throttle position sensor (TPS) is a potentiometer that sends a signal to the ECM which is proportional to the throttle shaft angle.

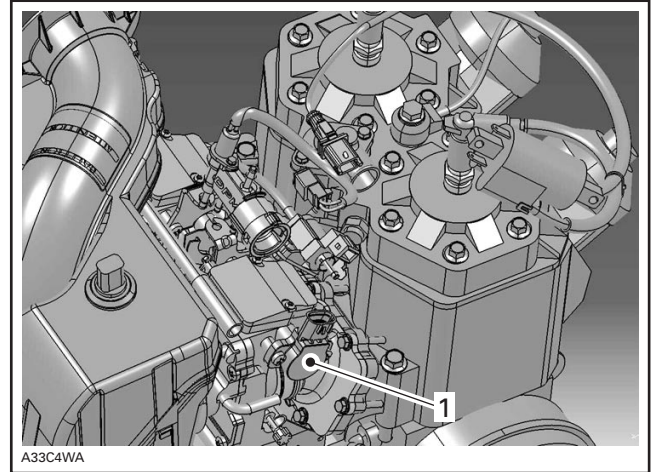

1. Throttle position sensor (TPS)

IMPORTANT: Prior to testing the TPS, ensure that mechanical components/adjustments are adequate according to CARBURETOR in AIR INDUCTION SYSTEM above.

IMPORTANT: Pin-out of TPS harness connector does not match the TPS sensor pin-out. The pin-out used in the following tests is the TPS harness connector pin-out.

CORRESPONDING PIN-OUT OF TPS HARNESS AND TPS SENSOR	
TPS HARNESS CONNECTOR	TPS CONNECTOR
pin 1	pin 3
pin 2	pin 2
pin 3	pin 1

The ECM may generate several fault codes pertaining to the TPS. Refer to SYSTEM FAULT CODES in DIAGNOSTIC PROCEDURES section for more information.

Wear Test

While engine is not running, activate throttle and pay attention for smooth operation without physical stops of the cable.

Connect vehicle communication kit (VCK) and use B.U.D.S. software.

Use the **Throttle Opening** display under **Monitoring**.

Section 05 ENGINE MANAGEMENT (POWER TEK)

Subsection 03 (COMPONENT INSPECTION, REPLACEMENT AND ADJUSTMENT)

Slowly and regularly depress the throttle. Observe the needle movement. It must change gradually and regularly as you move the throttle. If the needle "sticks", bounces, suddenly drops or if any discrepancy between the throttle movement and the needle movement is noticed, it indicates a worn TPS that needs to be replaced.

Voltage Test

To gain access to TPS, do the following:

- remove air intake silencer
- loosen carburetor clamps
- install small hose pinchers (P/N 295 000 076) on inlet and outlet coolant hoses connected to carburetor

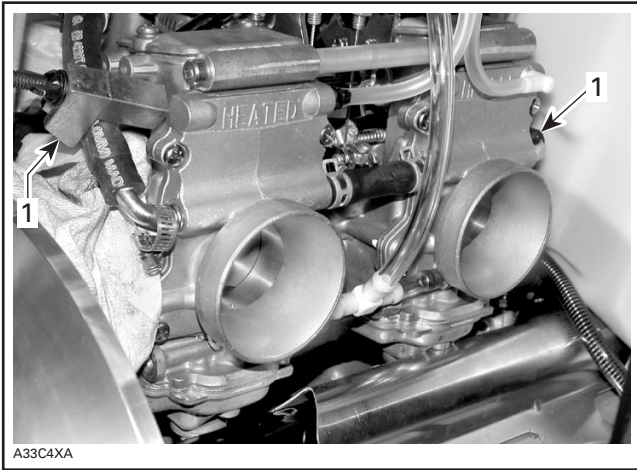

1. Install hose pinchers

- disconnect inlet and outlet coolant hoses from carburetors

NOTE: Keep throttle cable installed to avoid further adjustment.

- properly rotate and slightly pull out carburetors to gain access to TPS.

Connect vehicle communication kit (VCK) and use B.U.D.S. software.

Validation of Pins 2 and 3

Disconnect TPS connector. A fault code should appear in B.U.D.S. If so, it confirms pins 2 and 3 of TPS connector are working. Therefore, continue with validation of pins 1 and 3 below. If no fault code appears, do the following.

Disconnect TPS connector.

NOTE: To disconnect TPS connector, firmly press locking tab on top outer side of connector to release it.

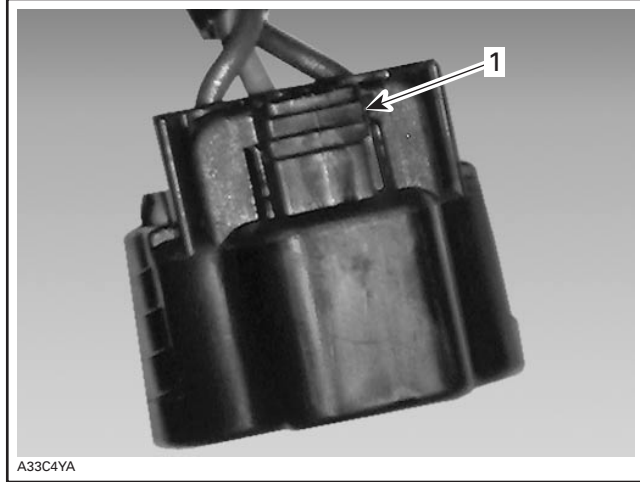

1. Firmly squeeze here

Disconnect ECM connector and check continuity of wires between TPS connector and ECM connector.

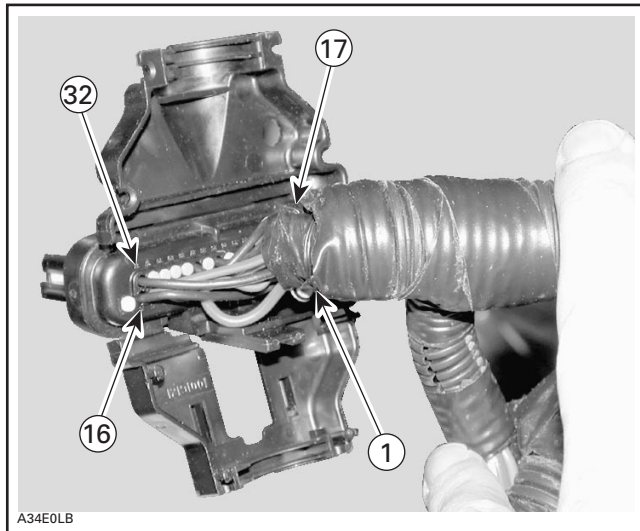

ECM CONNECTOR

TPS CONNECTOR	ECM CONNECTOR
PIN 2	DA-4
PIN 3	DA-1

If wire/connectors does not test good, repair/replace wire/connector. Otherwise, try a new ECM.

Section 05 ENGINE MANAGEMENT (POWER TEK)
Subsection 03 (COMPONENT INSPECTION, REPLACEMENT AND ADJUSTMENT)

Validation of Pins 1 and 3

Reconnect ECM connector.

Connect a voltmeter between pin 1 and 3 in TPS connector of wiring harness.

Voltage should be 5 V.

Otherwise, disconnect ECM connector and check continuity of wires between TPS connector and ECM connector.

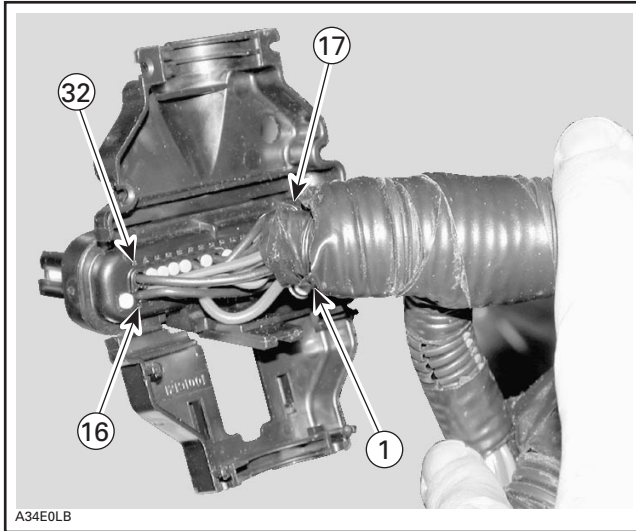

ECM CONNECTOR

TPS CONNECTOR	ECM CONNECTOR
PIN 1	DA-22
PIN 3	DA-1

If wire/connectors do not test good, repair/replace wire/connector. Otherwise, try a new ECM.

Perform resistance test to validate the TPS sensor.

Resistance Test

Reconnect the TPS connector.

Disconnect ECM connector.

Unscrew idle speed screw until there is a gap with the throttle lever stopper.

NOTE: The gap between idle speed screw and stopper is important to ensure throttle slide is completely closed to read TPS resistance values.

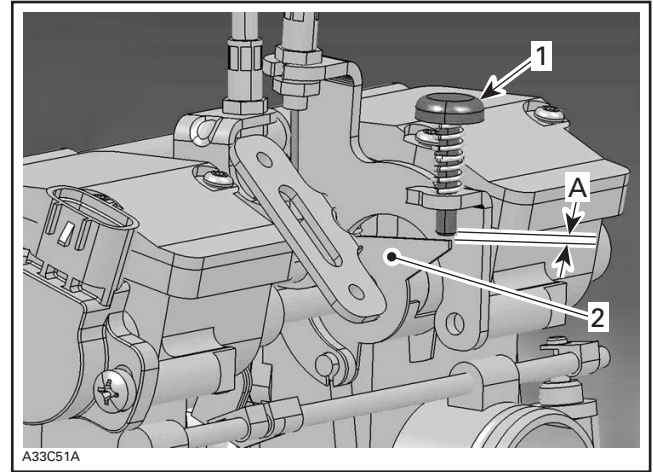

- 1. Idle screw
- 2. Throttle lever stopper
- A. Gap required here

Activate throttle lever 2 – 3 times to make sure throttle slides are fully closed.

Using a multimeter, check resistance values as per the following table.

ECM CONNECTOR		THROTTLE IDLE POSITION	WIDE OPEN THROTTLE POSITION
PIN	PIN	Resistance Ω	
22	4	3680 – 5520	480 – 720
22	1	4000 – 6000	4000 – 6000
4	1	480 – 720	3680 – 5520

NOTE: The resistance value should change smoothly and proportionally to the throttle movement. Otherwise, replace TPS.

If resistance values fail, replace TPS.

Since the idle screw was loosened, perform the **Closed Throttle Reset** procedure.

Replacement

See above to gain access to TPS.

Loosen two screws retaining the TPS.

Remove TPS.

Section 05 ENGINE MANAGEMENT (POWER TEK)

Subsection 03 (COMPONENT INSPECTION, REPLACEMENT AND ADJUSTMENT)

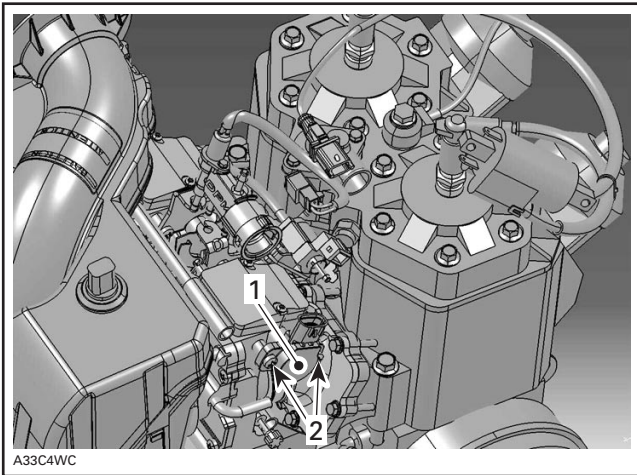

CARBURETOR

1. Throttle position sensor (TPS)
2. Screws

Install the new TPS.

Apply Loctite 243 on the TPS retaining screws, then torque to 3 N•m (27 lbf•in).

Reinstall remaining removed parts.

Proceed with the **Closed Throttle Reset**. See below.

Closed Throttle Reset (TPS)

Preparation

NOTE: This operation performs a reset of the values in the ECM.

This reset is very important. The setting of the TPS will determine the basic parameters for all fuel and ignition mappings.

NOTE: Reset must be done each time the throttle position sensor (TPS) is loosened or removed or carburetor or ECM is replaced. An improperly set TPS may lead to poor engine performance.

Ensure carburetor synchronization and throttle cable are properly adjusted prior to performing this setting. Refer to FUEL SYSTEM.

IMPORTANT: Having enough free-play in throttle lever is critical to properly set the values in ECM.

Setting Closed Throttle (TPS)

Unscrew idle speed screw until there is a gap with the throttle lever stopper.

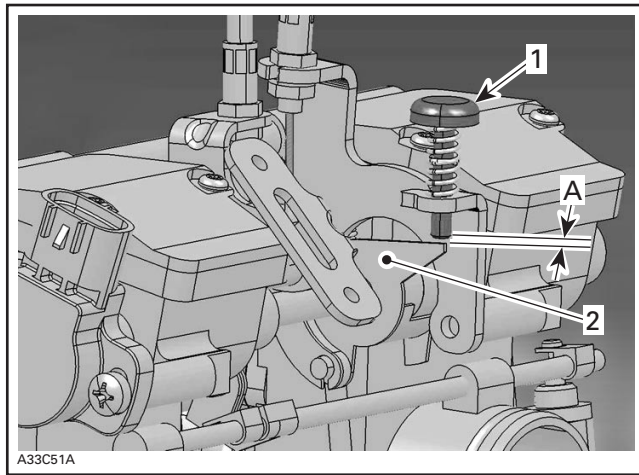

1. Idle screw
 2. Throttle lever stopper
- A. Gap required here

Activate throttle lever 2 – 3 times to make sure throttle slides are fully closed.

Connect vehicle communication kit (VCK) and use B.U.D.S. software.

Push the **Reset** button in the **Setting** tab of B.U.D.S.

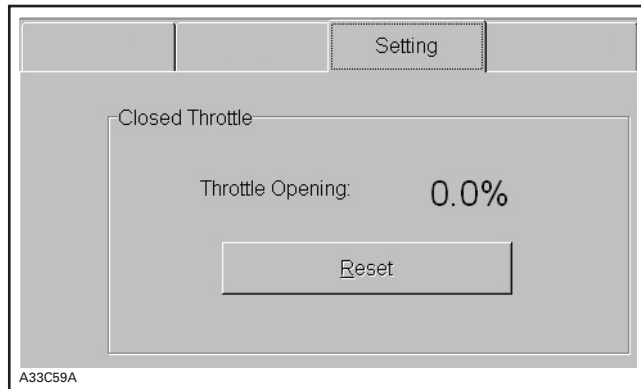

If TPS is not within the allowed range while resetting the **Closed Throttle**, the ECM will generate a fault code and will not accept the setting.

Perform the wide open throttle verification. In **Monitoring Tab** of B.U.D.S., check if throttle opening is within 95 and 100% when throttle lever is fully depressed.

Section 05 ENGINE MANAGEMENT (POWER TEK)
Subsection 03 (COMPONENT INSPECTION, REPLACEMENT AND ADJUSTMENT)

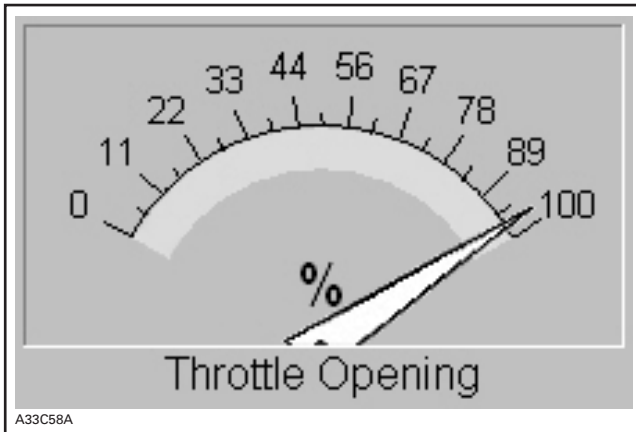

Adjust throttle cable as required to be within this value. Ensure that some free-play remains in the throttle cable at idle position.

As a preliminary setup, tighten idle screw until 4% appears under **Throttle opening** in **Setting** tab of B.U.D.S.

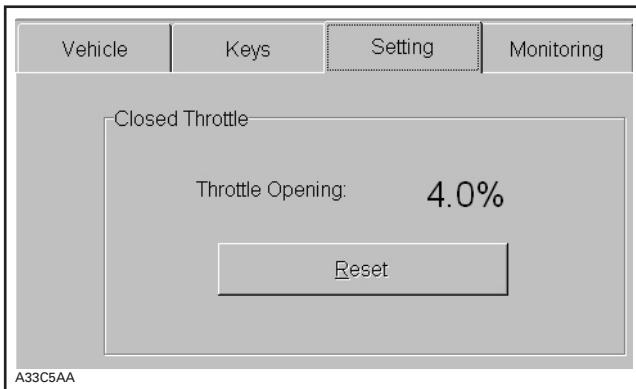

Adjusting Idle Speed

Disconnect VCK supply cable clips from battery. Start engine and bring it to its normal operating temperature.

Adjust idle speed to 1500 RPM.

If fault code(s) appear, refer to SYSTEM FAULT CODES in the DIAGNOSTIC PROCEDURES section for more information.

AIR TEMPERATURE SENSOR (ATS)

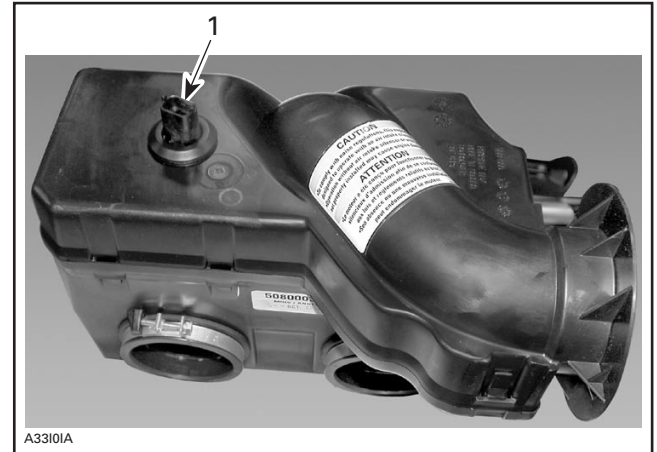

1. Air temperature sensor (ATS)

Dynamic Test

Connect vehicle communication kit (VCK) and use B.U.D.S. software.

Look **intake air** in **Monitoring** tab of B.U.D.S. It should show the ambient temperature. Otherwise, perform the following test.

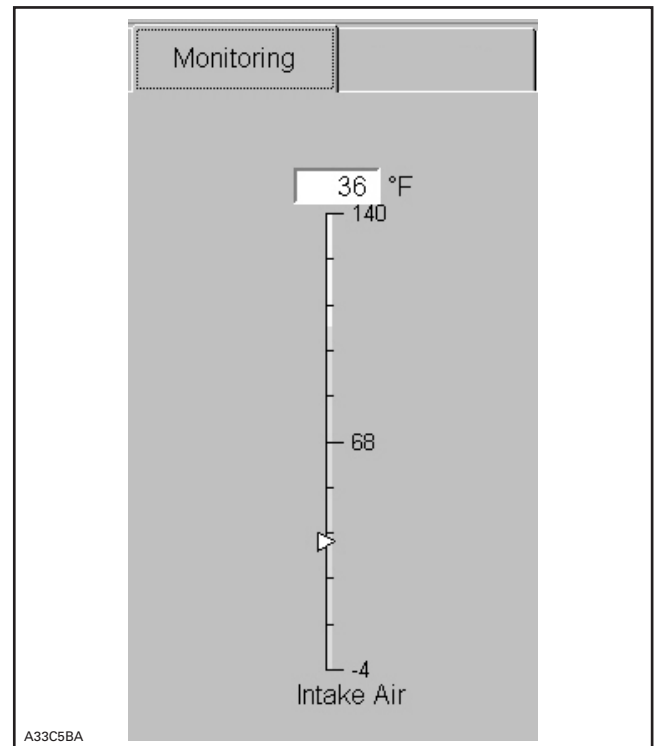

Section 05 ENGINE MANAGEMENT (POWER TEK)

Subsection 03 (COMPONENT INSPECTION, REPLACEMENT AND ADJUSTMENT)

Resistance Test

Refer to TEMPERATURE SENSOR TABLE at the beginning of this section.

Disconnect sensor connector and measure sensor resistance. If out of specifications, replace sensor.

If resistance tests good, **reconnect** the ATS and disconnect the ECM connector.

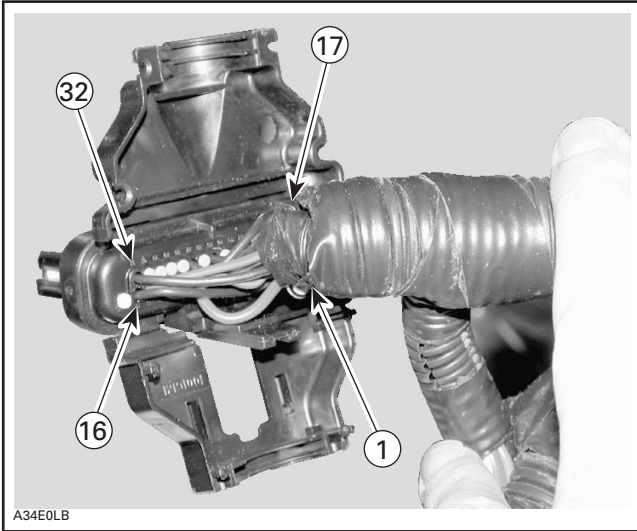

ECM CONNECTOR

Using a multimeter, measure resistance value again between terminals DA-19 and DA-1.

If resistance value is correct, try a new ECM. Refer to ECM REPLACEMENT procedures elsewhere in this section.

If resistance value is incorrect, repair the connectors or replace the wiring harness between ECM connector and the ATS.

Replacement

Unplug ATS connector.

Pull the ATS out of the air intake silencer.

Spray soapy water on ring. Install ring on air intake silencer then push the sensor in place.

Reconnect it.

COOLANT TEMPERATURE SENSOR (CTS)

NOTE: A dual sensor is used on this system. It supplies information to the ECM and to the temperature gauge.

Dynamic Test

Connect vehicle communication kit (VCK) and use B.U.D.S. software.

Look engine temperature in **Monitoring** tab of B.U.D.S. It should show the coolant temperature. Otherwise, perform the following test.

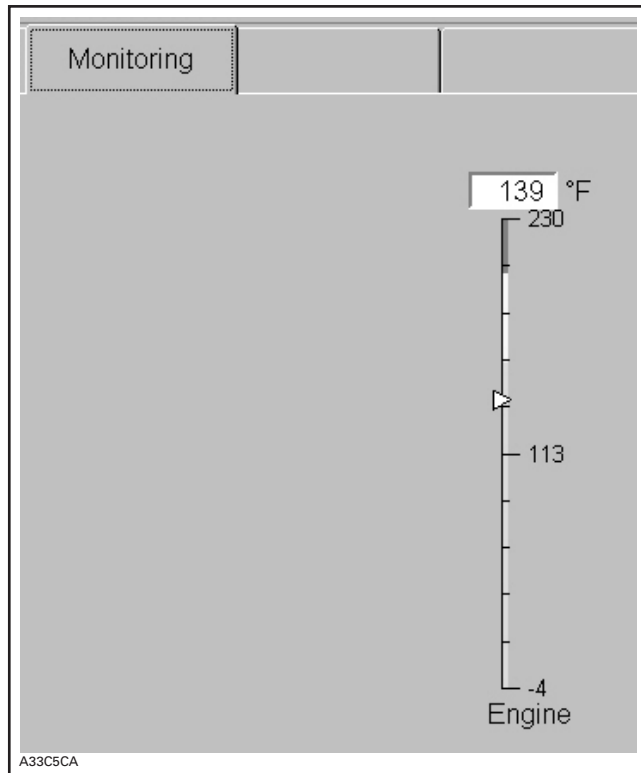

Resistance Test

Refer to TEMPERATURE SENSOR TABLE at the beginning of this section.

CTS Sensor for EMS

Disconnect sensor connector and measure sensor resistance between BLACK/GREEN and BEIGE/ORANGE wires of sensor. If out of specifications, replace sensor.

If resistance tests good, **reconnect** the CTS and disconnect the ECM connector.

Measure resistance value again between terminals DA-1 and DA-21 on ECM connector.

If resistance value is correct, try a new ECM. Refer to ECM REPLACEMENT procedures elsewhere in this section.

Section 05 ENGINE MANAGEMENT (POWER TEK)

Subsection 03 (COMPONENT INSPECTION, REPLACEMENT AND ADJUSTMENT)

If resistance value is incorrect, repair the connectors or replace the wiring harness between ECM connector and the CTS.

CTS Sensor for Temperature Gauge

Disconnect sensor connector and measure resistance value between BLACK and VIOLET wires of sensor.

If resistance value is incorrect, replace CTS sensor.

If resistance value is correct, check continuity of circuit and repair wiring harness/connectors.

Replacement

Lift rear of vehicle and securely support.

Disconnect CTS connector and remove CTS. Install the new CTS and torque to 12 N•m (106 lbf•in).

Reinstall remaining removed parts.

Refill engine coolant. If an important quantity of coolant spilled, bleed cooling system. Refer to LIQUID COOLING SYSTEM section.

AIR PRESSURE SENSOR (APS)

Sensor is integrated in ECM.

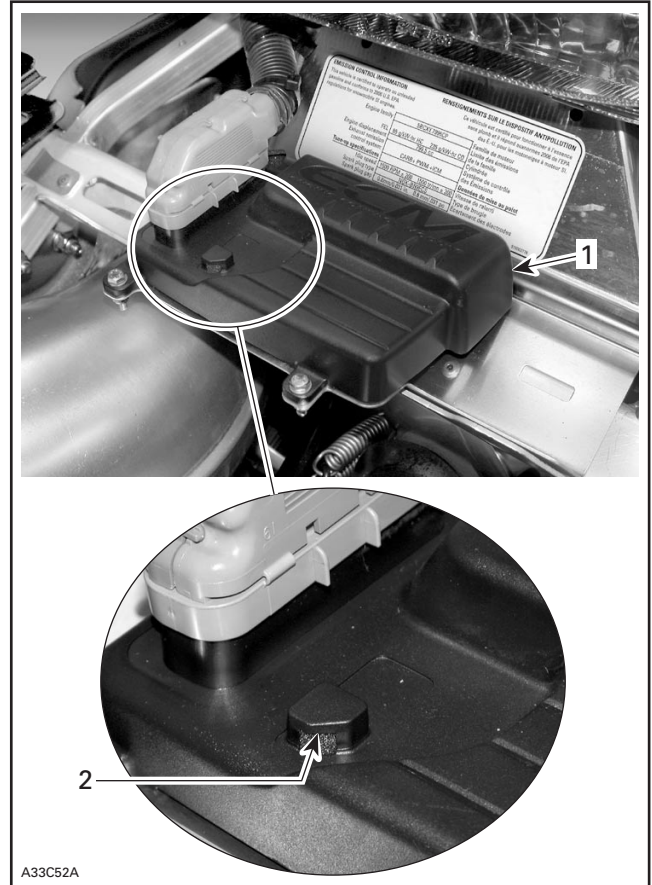

1. ECM
2. Air pressure sensor (APS)

Dynamic Test

Connect vehicle communication kit (VCK) and use B.U.D.S. software.

Look **atmospheric pressure** in **Monitoring** tab of B.U.D.S. It should show the actual pressure. Otherwise, perform the following.

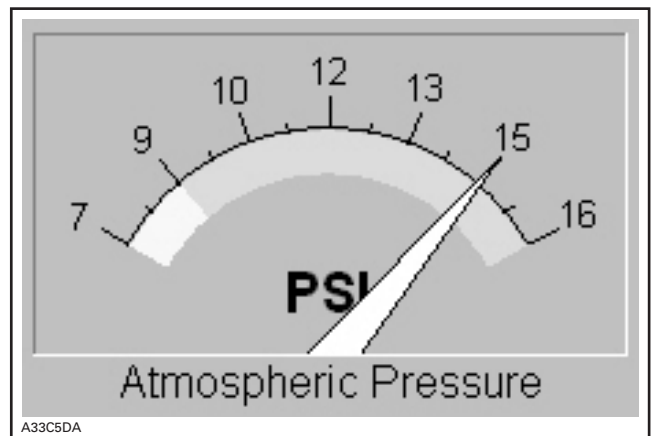

Section 05 ENGINE MANAGEMENT (POWER TEK)

Subsection 03 (COMPONENT INSPECTION, REPLACEMENT AND ADJUSTMENT)

Ensure pressure orifice is free of snow, ice and dirt. Temporarily remove the orifice filter and clean the area.

Check for fault codes in B.U.D.S.

If sensor does not work replace ECM.

KNOCK SENSOR (KS)



1. Knock sensor (KS)

Dynamic Test

Lift rear of vehicle off the ground and support it with a wide-base mechanical stand.

Using the vehicle communication kit (VCK) with the B.U.D.S. software, monitor the knock sensor using the Faults section.

Start the engine and bring engine speed above 5000 RPM. If no fault code occurs, the knock sensor is good.

NOTE: Ensure ignition coil cables are not close to knock sensor harness. This might generate a false fault code.

NOTE: Fault code P1326 might occur but it is not related with the knock sensor. If this code occurs, refer to B.U.D.S. for proper action to take.

Otherwise, do the following.

Ensure sensor and head contact surfaces are clean and mounting bolt and washer are correct and properly torqued down.

Check the knock sensor circuit on wiring harness.

Disconnect the connector from knock sensor harness.

Disconnect connector DA from the ECM and check continuity of circuit as per following table.

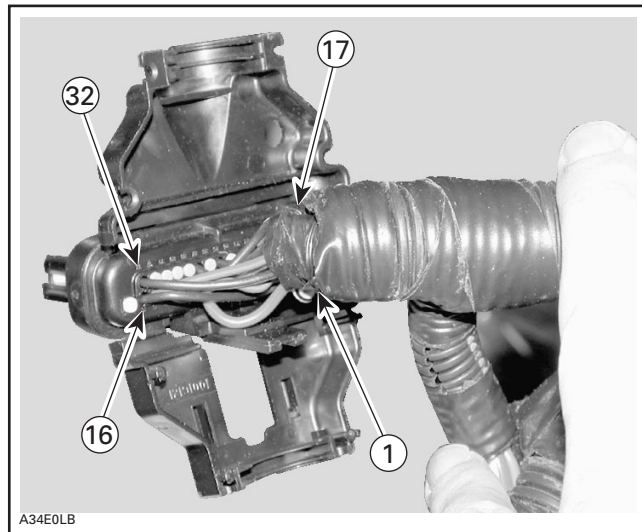

ECM CONNECTOR

CIRCUIT NUMBER (ECM connector)	KS CONNECTOR
DA-2	PIN 1
DA-20	PIN 2

If test is not good, repair the connector or replace the wiring harness between ECM connector and knock sensor.

If test is good, try a new knock sensor. If problem persists, try a new ECM.

Replacement

Unscrew and remove knock sensor from cylinder head.

Clean contact surface, then install the new knock sensor.

Torque screw to 29 N•m (21 lbf•ft).

CAUTION: Improper torque might prevent sensor to work properly and lead engine to severe damage of internal components.

Replug connector.

Section 05 ENGINE MANAGEMENT (POWER TEK)
Subsection 03 (COMPONENT INSPECTION, REPLACEMENT AND ADJUSTMENT)

E-RAVE SOLENOID

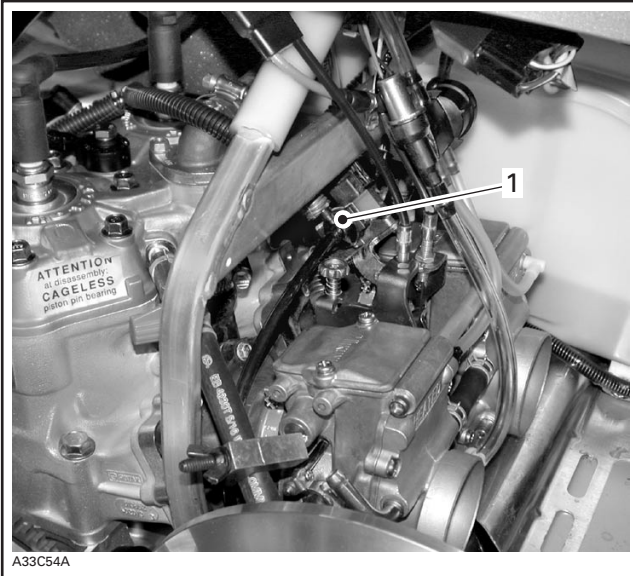

1. E-RAVE solenoid

NOTE: First ensure the problem is not related with tubes connection and RAVE valves themselves.

Connect vehicle communication kit (VCK) and use B.U.D.S. software.

Energize **RAVE** solenoid from **Activation** tab.

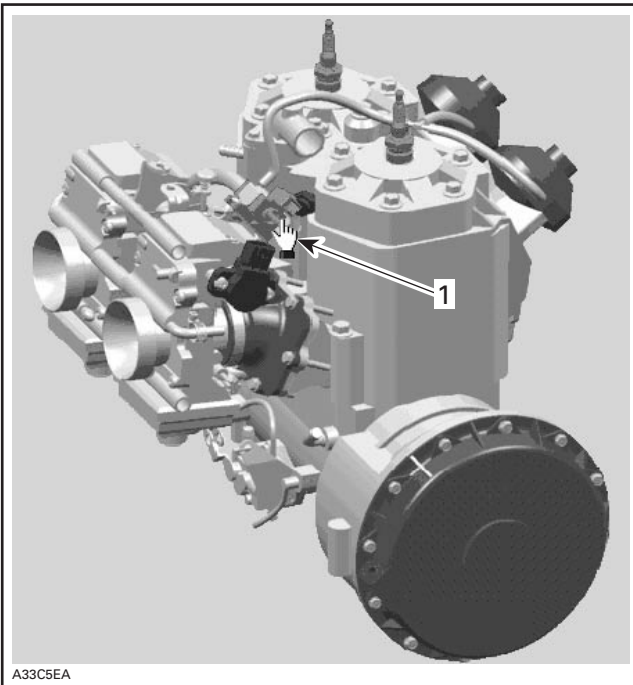

1. Activate here

This will validate the injector mechanical and electrical operation.

If the solenoid does not work, disconnect the connector from the solenoid.

Measure voltage between pin 2 (on harness side) and battery ground (engine ground on manual start models).

If 12 V is read, disconnect connector from the ECM and check continuity of circuit between pin DA-13 and pin 1. If continuity tests good, try a new ECM. Refer to ECM for replacement procedures.

If 12 V is not read, check the corresponding fuse(s), relay and continuity of circuit V V-2. If continuity is faulty, repair wiring/connector.

Heating Element

Unplug the 2-pin connector located besides E-RAVE.

Measure voltage between RED/YELLOW and BLACK wires of heating element.

If 12 V is read, check BLACK wire circuit. If good, replace E-RAVE solenoid.

If 12 V is not read, check the corresponding fuse(s), relay and continuity of circuits VH-1 and VH-2. If continuity is faulty, repair wiring/connector.

Replacement

To replace the E-RAVE solenoid, do the following:

- remove air intake silencer.
- slacken carburetor clamps
- install small hose pinchers (P/N 295 000 076) on inlet and outlet coolant hoses connected to carburetor

Section 05 ENGINE MANAGEMENT (POWER TEK)

Subsection 03 (COMPONENT INSPECTION, REPLACEMENT AND ADJUSTMENT)



1. Install hose pinchers

- disconnect inlet and outlet coolant hoses from carburetors

NOTE: Keep throttle cable installed to avoid further adjustment.

- properly rotate and slightly pull out carburetors to gain access to TPS

NOTE: Mark hose locations of E-RAVE solenoid for reinstallation.

- remove solenoid screws and solenoid.

For installation, reverse the removal procedure. Check/adjust engine idle speed.

DPM SOLENOID

Electrical Test

Connect vehicle communication kit (VCK) and use B.U.D.S. software.

Energize **Leaning valve** (DPM solenoid) from **Activation** tab.

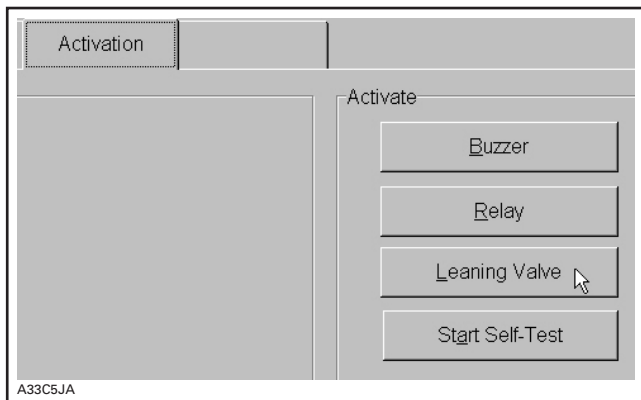

This will validate the solenoid mechanical and electrical operation.

Listen to or touch relay to feel it clicks.

If the solenoid does not work, disconnect the connector from the solenoid.

NOTE: To gain access to connector pins, unlock connector and slide it out toward oil tank. Refer to WIRING DIAGRAMS.

Measure voltage between pin 2 of DPM solenoid on harness side, and battery ground (engine ground on manual start models).

If 12 V is read, disconnect connector from the ECM and check continuity of circuit between pin DA-29 and pin 1. If wire/connector tests good, try a new ECM. Refer to ECM for replacement procedures.

If it does not read 12 V, check the corresponding fuse(s), relay and continuity of circuit DP-2. If continuity is faulty, repair/replace wire/connector.

Replacement

Refer to FUEL SYSTEM.

IGNITION COIL



RH SIDE OF VEHICLE

1. Ignition coil

The ECM energizes the primary side of ignition coil.

Connect vehicle communication kit (VCK) and use B.U.D.S. software.

Energize **ignition coil** from **Activation** tab.

Section 05 ENGINE MANAGEMENT (POWER TEK)

Subsection 03 (COMPONENT INSPECTION, REPLACEMENT AND ADJUSTMENT)

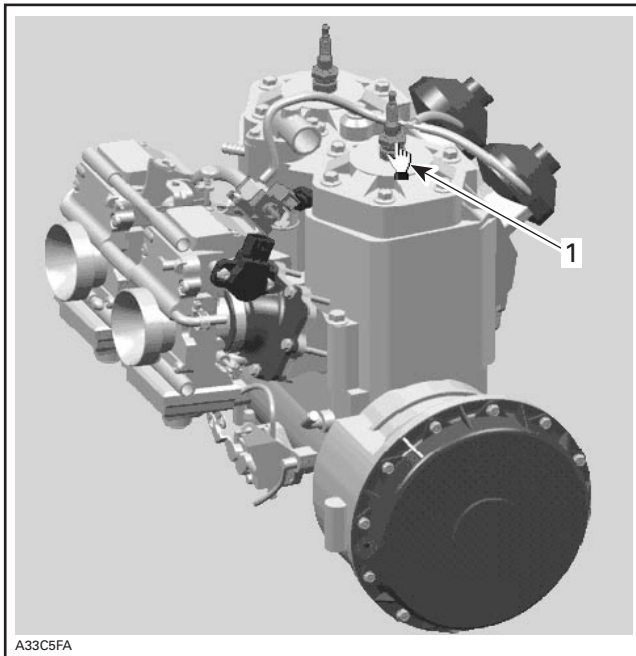

1. Activate here

Remove spark plugs and reconnect to cable. While spark plug rests against a metallic part of the engine, activate ignition coil with B.U.D.S. and check if there is a spark. Otherwise, perform the following checks.

NOTE: Keep in mind that ignition coil can still be faulty particularly at high RPM with higher voltage requirements.

Resistance Test

NOTE: Keep in mind that an ignition coil with good resistance measurement can still be faulty. Voltage leak can occur at high voltage level which is not detectable with an ohmmeter. Replacing the ignition coil may be necessary as a test.

Using a multimeter, check the resistance of primary winding.

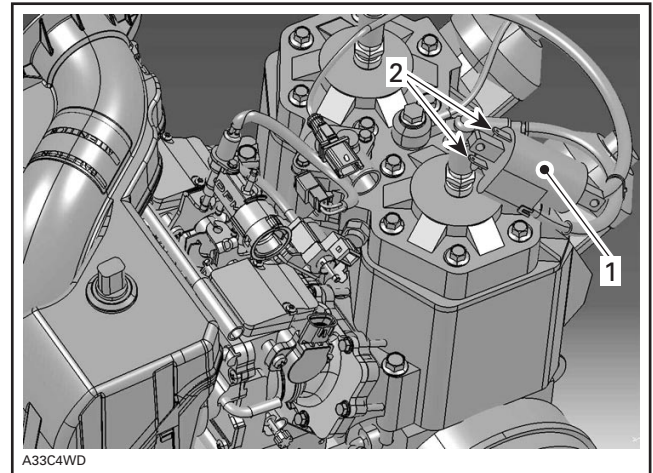

1. Ignition coil
2. Terminals

For primary winding, check the resistance between terminals on ignition coil.

The resistance should be between 0.41 and .46 Ω at 20°C (68°F).

If the resistance of winding is not good, replace the ignition coil.

Measure secondary winding through ignition cable caps.

The resistance should be around 13.85 k Ω to 21.65 k Ω at 20°C (68°F).

ENGINE START/RER SWITCH

Connect vehicle communication kit (VCK) and use B.U.D.S. software.

A quick operation test can be done using the **Monitoring** section. With engine cut-out at OFF, press the START/RER button and look at the START/RER button LED. It should turn on, indicating the starting system is working on the input side of the starting system (START/RER button, ECM and wiring). If it does not turn on, you know now the problem is on the output side of the starting system (ECM output signal to starting solenoid, wiring harness going to the solenoid and starter motor. Refer to STARTING SYSTEM. Otherwise, check the input side as follows.

Section 05 ENGINE MANAGEMENT (POWER TEK)

Subsection 03 (COMPONENT INSPECTION, REPLACEMENT AND ADJUSTMENT)



1. Activate here

Disconnect 8-pin connector of the steering harness.

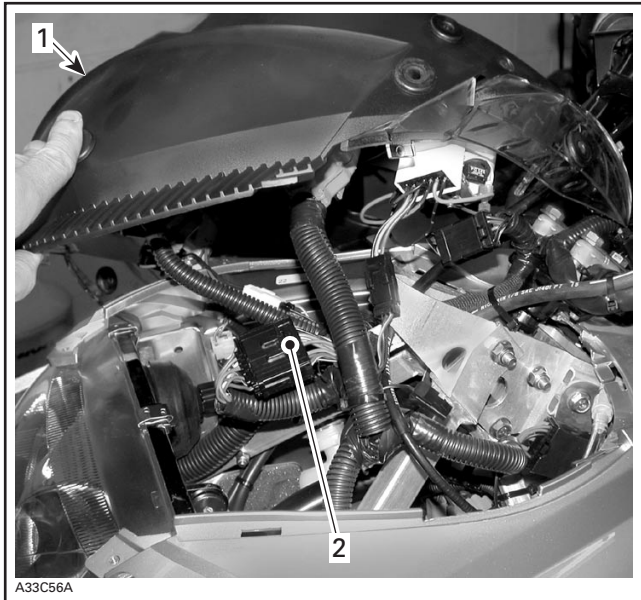

1. Dashboard
2. 8-pin connector

Measure resistance at connector between pins HG-5 and HG-8. The reading should change from infinitely high to 0 Ω when pressing start/RER button.

If resistance test fails, check wires continuity up to start/RER switch. If resistance is good, replace switch.

Measure voltage between pin HG-5 and battery ground (engine ground on manual start models). If it reads 12 V, disconnect ECM connector and check ground circuit between HG-8 and DA-8. If it tests good, try a new ECM.

If it does not read 12 V, check supply circuit wires at HG-5 going back to battery (voltage regulator on manual start models).

RER Operation

When RER works erratically or engine stalls, do the following.

- Check both trigger coils and corresponding wiring. Refer to TESTING PROCEDURES
- Check engine compression. A low compression engine may result in engine stall making you think the problem is an electronic problem.
- Check piston condition. Remove exhaust system and reed valves on intake side. Verify piston condition through the intake and exhaust ports. Look for scoring on piston skirts. Scored piston skirts may result in RER working erratically making you think the problem is an electronic problem.

When it does not work at all, check start/RER switch as explained above.

DIGITALLY ENCODED SECURITY SYSTEM (DESS)

If 2 short beeps are not heard when starting the engine, test beeper operation.

Connect vehicle communication kit (VCK) and use B.U.D.S. software.

Energize **Buzzer** from **Activation** tab.

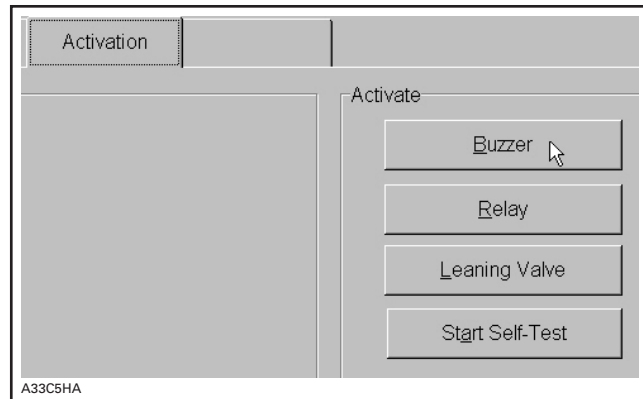

If beeper properly works, refer to DIAGNOSTIC PROCEDURES.

The following continuity tests can also be performed using an ohmmeter.

Disconnect DESS switch wires.

Section 05 ENGINE MANAGEMENT (POWER TEK)
Subsection 03 (COMPONENT INSPECTION, REPLACEMENT AND ADJUSTMENT)

**DESS Post Verification — Tether
Cord Cap Removed**

Connect test probes to switch BLACK/GREEN and BLACK/WHITE wires. Measure resistance, there should be NO continuity (open circuit).

Connect one test probe to the WHITE/GREY wire and the other test probe to the switch top terminal. Measure resistance, it must be close to 0 ohm.

Connect one test probe to the BLACK/GREEN wire and the other test probe to the switch ring. Measure resistance, it must be close to 0 ohm.

**DESS Post Verification — Tether
Cord Cap on DESS Post**

Connect test probes to switch BLACK/GREEN and BLACK/WHITE wires. Measure resistance, it must be close to 0 ohm.

OVERVIEW

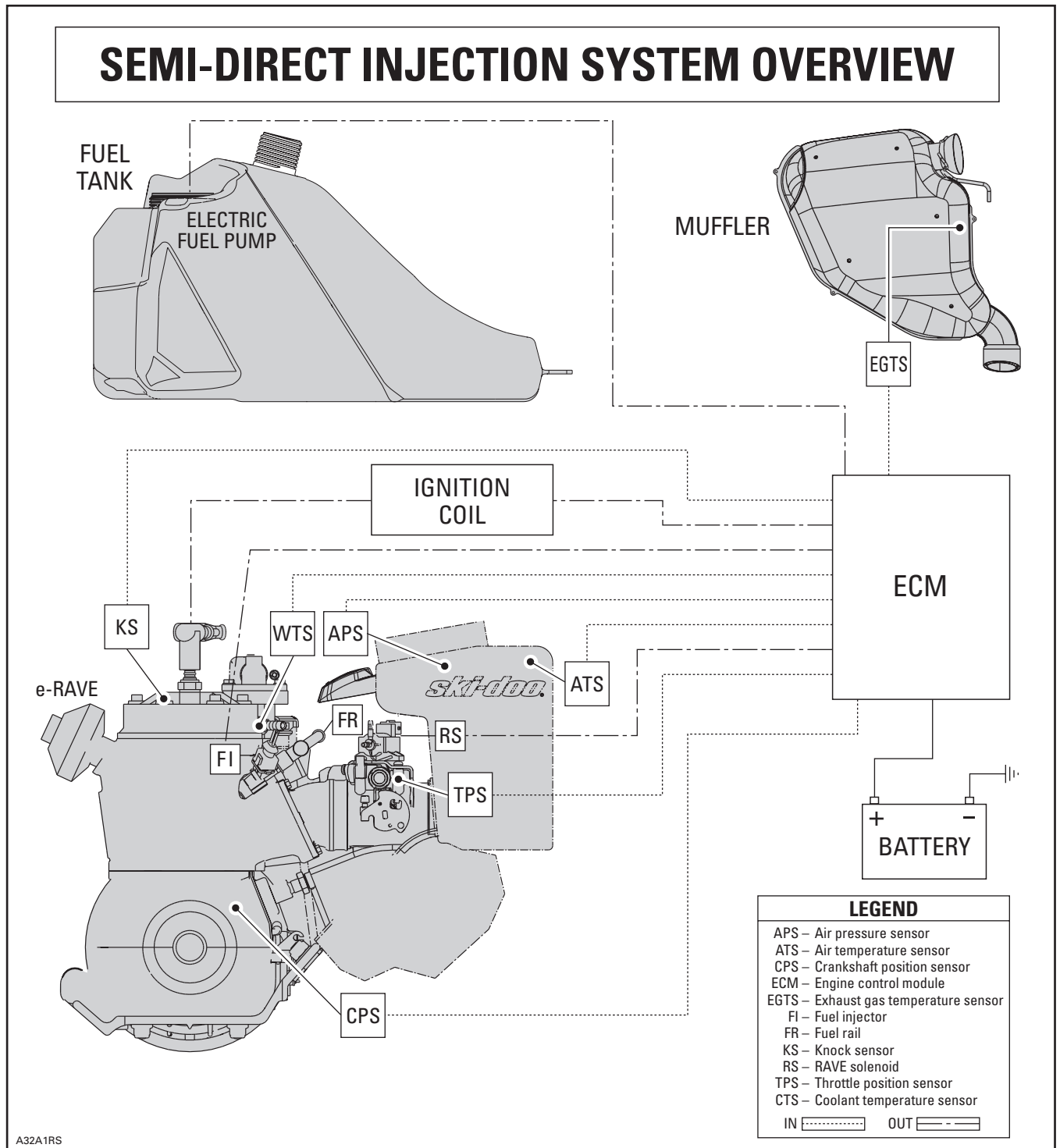

A32A1RS

TYPICAL

Section 06 ENGINE MANAGEMENT (SDI)

Subsection 01 (OVERVIEW)

OPERATING PRINCIPLE

For this SDI 2-stroke engine, a highly advanced engine management system (EMS) has been used to ensure a high power output combined with cleaner combustion. An ECM (Engine Control Module) calculates the proper air/fuel mixture and ignition timing for each cylinder separately. The fuel is injected into the transfer port of each cylinder.

CHARGING SYSTEM

The magneto is the primary source of electrical energy. It transforms magnetic field into electric current (AC).

The magneto has a 3 phases, delta wound stator on 18 poles. Capacity is 480 watts.

AC current is rectified and regulated between 13.4 and 15 volts for the vehicle electrical system. It supplies the ECM with DC current.

Vehicle 12-volt battery supplies the ECM with DC current.

IGNITION SYSTEM

Double ignition coil has two separate windings, one for each spark plug.

Ignition coil induces voltage to a high level in the secondary windings to produce a spark at the spark plug.

Two separate windings circuits are switched to ground through the ECM. Each winding provides high voltage to its corresponding spark plug.

This ignition system allows spark plugs to spark independently.

CAUTION: Do not interchange spark plug cables. Match reference (PTO or MAG printed on high tension cable yellow tag) with corresponding cylinder spark plug.

Double ignition coil is located underneath air silencer.

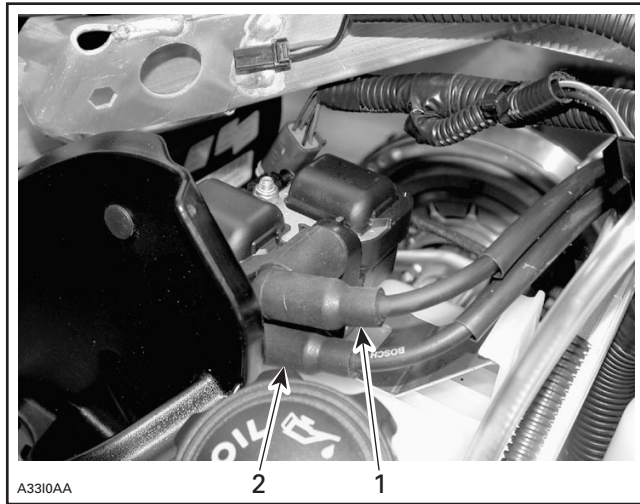

TYPICAL

1. PTO side high tension cable
2. MAG side high tension cable

AIR INDUCTION

Through air filter mounted LH side panel, air goes into air silencer. The ECM measures at this point air pressure and temperature. Then, air for combustion is drawn through two throttle bodies. The air flow is controlled by two throttle plates. The air continues through the reed valves into the cylinder base then the crankcase.

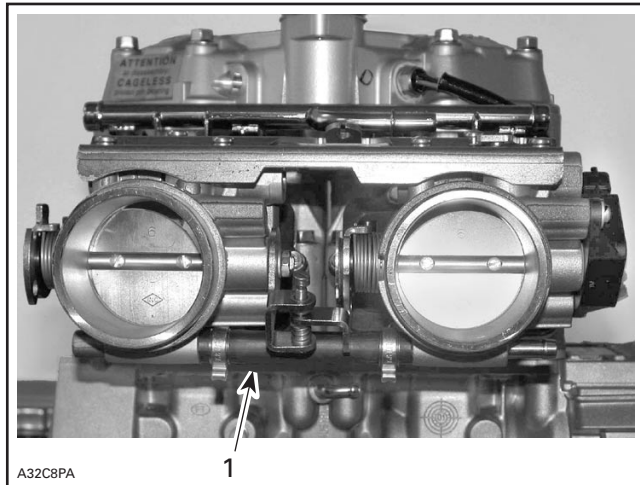

THROTTLE BODY ASSEMBLY

1. Coolant-heated line

FUEL DELIVERY SYSTEM

Diaphragm Fuel Pump

A conventional diaphragm fuel pump is used to supply fuel to the electric fuel pump reservoir located inside fuel tank. This reservoir is the fuel supply for the electric fuel pump. This system allows a more consistent fuel delivery under extreme riding angles and when the fuel tank level is low, which increases the fuel range per tank.

NOTE: A bypass hole in the upper section of the pump reservoir allows fuel to enter or exit the reservoir depending of the conditions.

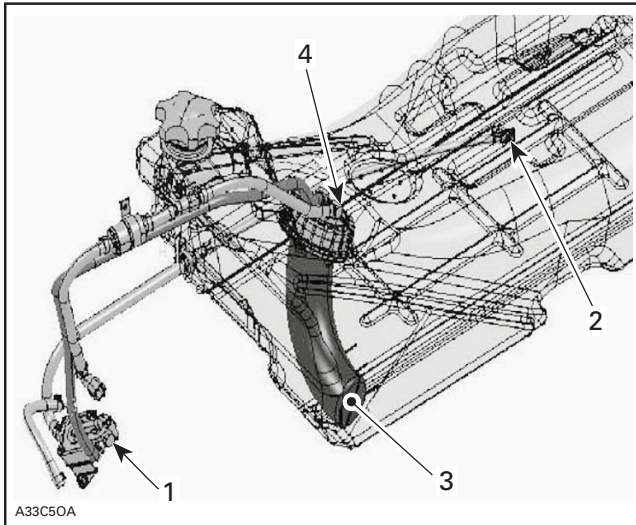

1. Diaphragm pump
2. Fuel pick-up
3. Pump reservoir
4. Electric fuel pump

Electric Fuel Pump and Fuel Pressure Regulator

They provide fuel pressure and flow rate to the system.

The fuel pump module is located inside the fuel tank. The module includes the fuel pump and the fuel pressure regulator. The fuel pump inlet includes a filter.

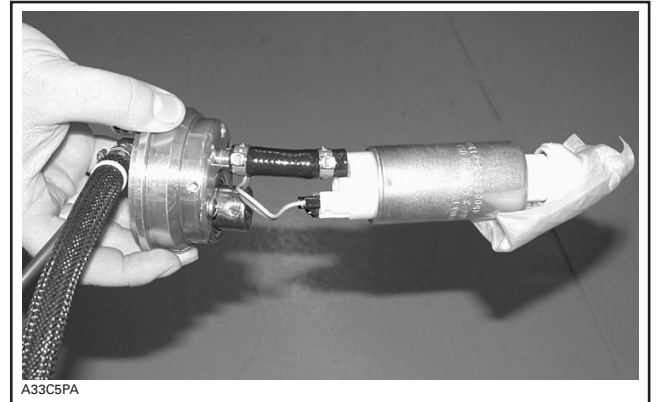

The fuel pressure regulator controls the pressure in the system and allows the excess of fuel to return to the fuel tank. The fuel pressure regulator regulates the fuel pressure at 400 kPa (58 PSI).

Fuel Rail

The fuel rail is a small tube on which the four injectors are mounted. It ensures at all times that enough fuel at the right pressure can be delivered to the fuel injectors. The fuel rail is fed by the fuel pump module.

Fuel Injectors

Fuel injectors (two per cylinder) are used to inject fuel into the transfer port of cylinder.

Throttle Body

It is a dual throttle body mounted on the engine intake side. Fitted on this dual throttle body, there is a TPS (Throttle Position Sensor) that sends information to the ECM.

In-Line Fuel Filter

The in-line 10 micron fuel filter is fastened under the steering console. It should be replaced annually.

Section 06 ENGINE MANAGEMENT (SDI)

Subsection 01 (OVERVIEW)

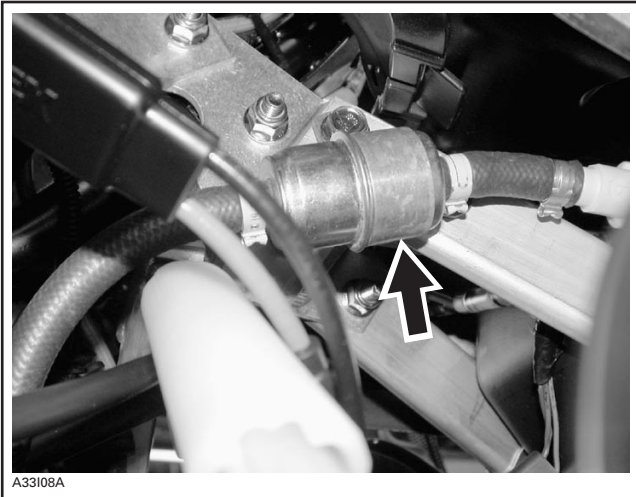

ENGINE MANAGEMENT SYSTEM (EMS)

The EMS (Engine Management System) is equipped with an ECM which controls the ignition system, the vehicle electrical system, the fuel injection system and the electronically controlled RAVE.



TYPICAL — ECM

The ECM is mounted in the front of the vehicle.



The ECM is directly powered by the battery. It is responsible for the following engine management/electrical functions:

- interpreting information
- distributing information
- start/stop function
- DESS (Digitally Encoded Security System)
- ignition control
- injection control

NOTE: The ECM applies the proper maps (injection and ignition) for optimum engine operation in all conditions.

- engine RPM limiter
- RER (Rotax Electronic Reverse)
- etc.

The ECM features a permanent memory that will keep the programmed tether cord cap(s) code, fault codes and other vehicle information, even when the battery is removed from the vehicle.

Manual Start Models

While cranking, the magneto sends AC current to the voltage regulator/rectifier that in turn, sends a signal to the ECM. This wakes up the Engine Management System and activate the starting system relay (R1) and the capacitor relay (R4). Just a small rotation of the engine is needed to wake-up the ECM.

The RER switch may also be used to wake-up the Engine Management System.

Waking-up the EMS before doing a start attempt result in faster start-up.

Waking-up the Engine Management System powers the ECM, the fuel pump, the ignition coil, the injectors, and the gauges.

The battery is required to supply current mainly to the fuel pump to allow a fuel pressure buildup. An easy way to acknowledge if the Engine Management System is woken-up, verify if gauges are lit up.

The capacitor has two functions. It is used to stabilize battery voltage when voltage from the voltage regulator/rectifier is charging the small battery. It also gives the possibility to be able to start the engine even if the battery is very low. In this case, starting the engine may be more difficult and will require the very complete stroke of the starting rope.

The capacitor relay prevents the capacitor to be connected to the battery when the engine is not running to allow safe vehicle maintenance (disconnection and reconnection of the capacitor).

Electric Start Models

When the start/RER switch is activated, it wakes up the EMS and power the starting system relay (R1), the ECM, the fuel pump, the ignition coil, the injectors, and the gauges. Then, if the cut-off switch and the DESS switch are in position to allow starting and start/RER switch is hold, the starter solenoid relay is activated.

All Models

When engine reaches approximately 800 RPM, the ECM activates the headlights and accessory relay (R2).

ECM — GENERAL FUNCTIONS

Automatic Power Shut-Down

The ECM is equipped with an automatic power shut-down. This feature prevents the battery from losing its charge if the tether cord cap is left on the post when the engine is not running for more then 30 seconds. The ECM will remain offline until the electric starter or the rewind starter is activated. The ECM will shut down all outputs after 5 seconds when the tether cord cap is removed.

Digitally Encoded Security System (DESS)

The following components are specially designed for this system: ECM, tether cord cap and DESS post.

This system allows the engine to reach pulley engagement speed only if a programmed tether cord cap is installed on DESS post.

The tether cord cap contains a magnet and a ROM chip. The magnet actually closes the reed switch inside the post which is the equivalent of a mechanical ON/OFF switch. The chip has a unique digital code.

NOTE: Actually, it is the memory of the ECM which is programmed to recognize the digital code of the tether cord cap. This is achieved with the VCK (Vehicle Communication Kit) (P/N 529 035 981). Refer to their operation manual or help system to program a tether cord cap.

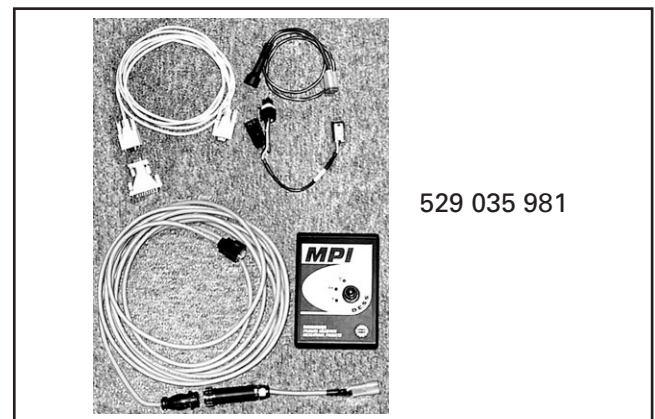

The system is quite flexible. Up to 8 tether cord caps may be programmed in the memory of the ECM. They can also be erased individually.

NOTE: If desired, a tether cord cap can be used on other vehicle equipped with the DESS. It only needs to be programmed for that vehicle.

When starting the engine with a tether cord cap on the post, the DESS is activated and will emit audible signals:

- 2 short beeps indicate a working tether cord cap. Vehicle can be driven.
- short repetitive beeps indicates a wrong tether cord cap is being used or that something is defective. Vehicle can not be driven.

Section 06 ENGINE MANAGEMENT (SDI)

Subsection 01 (OVERVIEW)

Gauges Current Supply

Gauges are supplied with current for 30 seconds when connecting the tether cord cap on its post and momentarily pressing the START/RER switch.

NOTE: On electric start models, setting engine cut-out switch to OFF will prevent engine starting.

NOTE: Each time the tether cord cap is connected to the post and START/RER switch is depressed, the fuel pump is activated for 2 seconds to build up pressure in the fuel injection system.

Engine Starting

If the ECM recognizes a valid tether cord cap, it allows engine to rev above 3000 RPM.

Engine RPM Limiter

The ECM will limit the maximum engine speed.

Low-Oil Level Warning Device

When the oil falls under a certain level, the low oil level LED will be illuminated. The beeper will also be activated intermittently.

High Coolant Temperature Warning Device

When the coolant temperature is getting too high, the ECM sends out signals to the beeper and the high temperature LED.

Power Distribution

Accessories are protected by fuses located in the fuse holder. Fuses are identified besides their holder.

IMPORTANT: Engine-related sensors and injectors are continuously powered from the battery. **The ECM switches the ground to complete the electrical circuits it controls.** Take this into account when troubleshooting the electrical system.

Manual Start Models

The system uses 3 relays: an ignition/injectors, electric fuel pump and starting system relay (R1), a second for the lighting system and the accessories (R2) and a third for the capacitor circuit (R4).

Electric Start Models

The system uses 2 relays: an ignition/injectors, fuel pump and starting system relay (R1) and a headlights and accessories relay (R2).

EMS — ENGINE MANAGEMENT SYSTEM FUNCTIONS

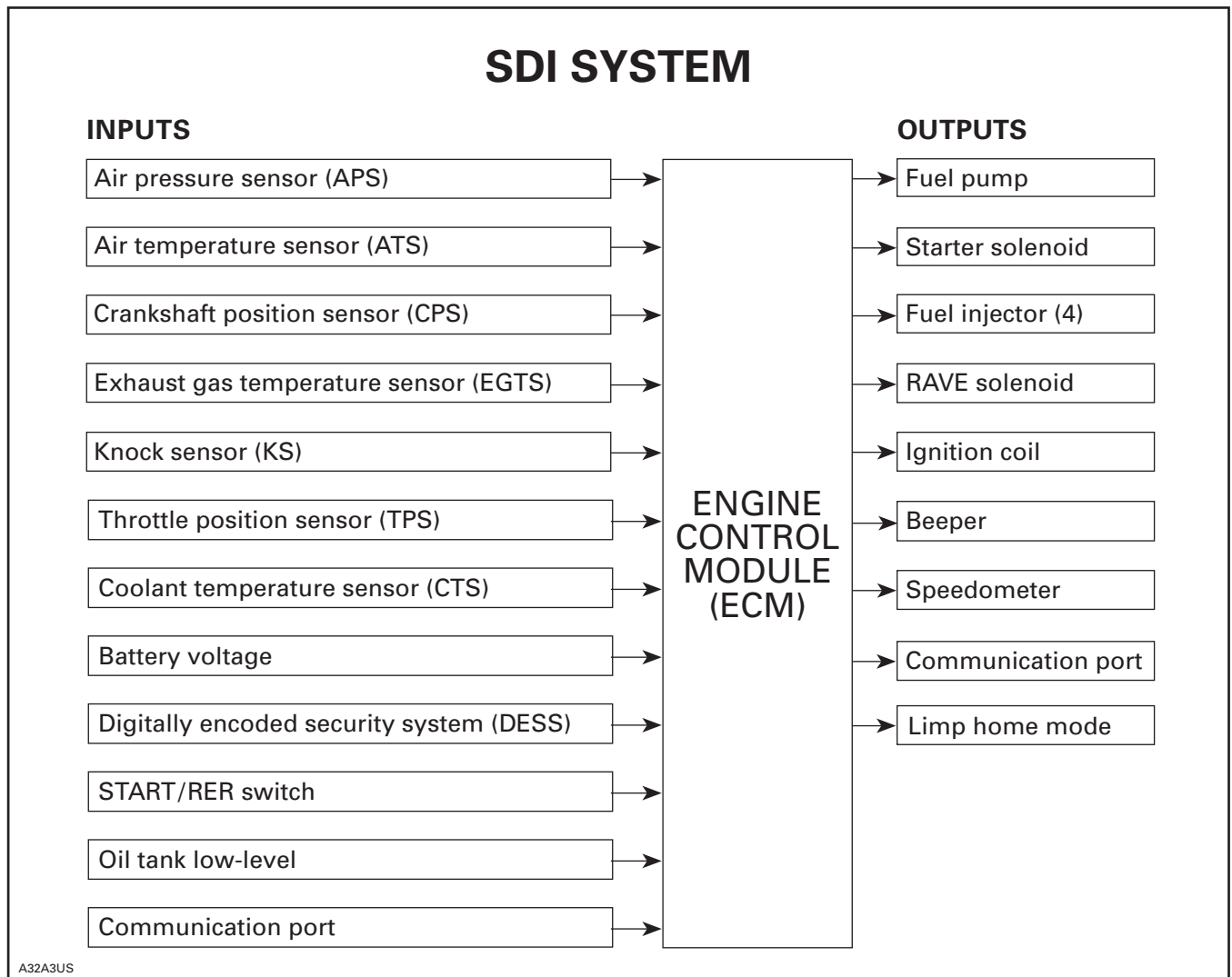

This engine management system controls the fuel injection, the ignition timing and the electronically controlled RAVE.

As shown in the SDI CONTROL SYSTEM illustration, the ECM is the central point of the engine management system. It reads the inputs, makes computations, uses pre-determined parameters and sends the proper signals to the outputs for proper engine management.

The ECM also stores the fault codes and general information such as: operating conditions, vehicle hours, serial numbers, customer and maintenance information.

ELECTRONIC FUEL INJECTION

The ECM receives the signals from different sensors which indicate engine operating conditions at milli-second intervals.

Signals from sensors are used by the ECM to determine the injection parameters (fuel maps) required for optimum air-fuel ratio.

The CPS and TPS are the primary sensors used to control the injection and ignition timing. Other sensors are used for secondary input.

Section 06 ENGINE MANAGEMENT (SDI)

Subsection 01 (OVERVIEW)

IGNITION TIMING

The ECM is programmed with data (it contains ignition mappings) for optimum ignition timing under all operating conditions. Using engine operating conditions provided by the sensors, the ECM controls the ignition timing for optimum engine operation.

ELECTRONICALLY CONTROLLED RAVE

The electronically controlled RAVE (E-RAVE) offers two performance enhancements to conventional RAVE system.

- The opening of the valve is activated electronically. A solenoid holds the valve closed. The ECM monitors altitude, engine temperature, throttle position and RPM, and operates the solenoid in optimal conditions.
- The valve is opened by crankcase pressure. The greater and more constant pressure from the crankcase opens the valve more crisply.

NOTE: An electric heating element has been added to the RAVE solenoid to ensure proper function in very cold weather.

KNOCK SENSOR

A knock sensor is mounted on top of the cylinder head. It detects specific vibration that would be typically generated by engine detonation. If detonation occurs, the knock sensor detects it and the ECMs retards the ignition advance and extend the injection period temporarily (it goes in a specific mode) until detonation stops.

ENGINE MODES OF OPERATION

The ECM controls different operation modes of the engine to allow proper operation for all possible conditions: Cranking, start up, idle, warm up, normal operation, engine speed limiter, flooded engine and limp home (see below).

FLOODED ENGINE (DROWNED MODE)

If the engine does not start and it is fuel-flooded, this special mode can be activated to prevent fuel injection and to cut ignition while cranking. Proceed as follows:

With tether cord cap on its post while engine is stopped, press completely and HOLD throttle lever.

Manual Start Models

Crank engine several times.

Electric Start Models

Press the START/RER button.

The engine should be cranked for 20 seconds. Release start/RER button.

All Models

In the engine drowned mode, engine cannot start. It is required to release throttle lever and to start/crank engine again to allow starting.

NOTE: If the engine does not start, it may be necessary to replace the spark plugs.

MONITORING SYSTEM

The ECM monitors the electronic components of the engine management system and other components of the electrical system.

When a fault occurs, it sends a signal to the check engine LED or also to the beeper to inform the driver of a particular condition. Refer to the DIAGNOSTIC PROCEDURES.

LIMP HOME MODES

Besides the signals as seen above, the ECM may automatically set default parameters to ensure the adequate operation of the vehicle if a component of the engine management system is not operating properly.

NOTE: Sensor failures will not lead automatically to a limp home mode. The check engine LED will turn on and in some cases the beeper.

The engine RPM may be limited if some critical components fail. In this case, releasing throttle and letting the engine returning to idle speed may allow normal operation to come back. If it does not work, try removing and reinstalling the tether cord cap on DESS post.

These performance-reduced modes allow the rider to go back home which would not be possible without this advanced system. Refer to the DIAGNOSTIC PROCEDURES for a complete chart.

DIAGNOSTIC MODE

The malfunctions are recorded in the memory of the ECM. The memory of the ECM can be checked using the VCK (Vehicle Communication Kit) (P/N 529 035 981) to see the fault codes. Refer to the DIAGNOSTIC PROCEDURES section.

ROTAX ELECTRONIC REVERSE (RER)

There is 3 main components used for the RER system : the start/RER switch, the ECM and the crankshaft position sensor.

The ECM receives signals from the crankshaft position sensor (CPS) for the following functions:

- Forward engine rotation.
- Reverse engine rotation.
- Crankshaft position and engine RPM.

The ECM recognizes a signal sent by the START/RER switch.

When switch is activated and engine is not running, ECM allows normal engine starting.

When switch is activated and engine is running, ECM cuts off ignition. Therefore, engine RPM gradually drops. When engine reaches a low threshold RPM, ECM sends an ignition spark at a great advance creating a thrust which reverses engine rotation.

Under a threshold low RPM or above drive pulley engagement speed, the RER function is disabled. Nothing takes place when pressing Start/RER button.

DIAGNOSTIC PROCEDURES

SERVICE TOOLS

Description	Part Number	Page
GRAY diagnostic key	529 035 896	246
supply harness.....	529 035 869	245
VCK (Vehicle Communication Kit).....	529 035 981	245

GENERAL

Here is the basic order suggested to diagnose a suspected engine management or fuel injection related problem:

- Check the chart in TROUBLESHOOTING section to have an overview of problems and suggested solutions.
- Check if the engine management system (EMS) pilot lamp lights up. If so, use the VCK (Vehicle Communication Kit) and look for fault codes to diagnose the trouble.
- Check all fuses, relay(s), battery and capacitor (on so equipped models).
- Check fuel pressure.
- Check spark plugs condition.
- Check all connections of the wiring harness.

Refer to COMPONENT INSPECTION, REPLACEMENT AND ADJUSTMENT section for procedures.

TROUBLESHOOTING

The following chart is provided to help in diagnosing the probable source of simple troubles.

Monitoring Beeper Coded Signals

CODED SIGNALS	POSSIBLE CAUSE	REMEDY
2 short beeps (when engine is started). DESS/RER pilot lamp also blinks.	Confirms that proper tether cord cap is installed. Engine can rev above clutch engagement.	No problem detected. Good ride.
1 short beep every 1.5 seconds (when engine is started). DESS/RER pilot lamp also blinks. Engine cannot reach pulley engagement speed. Vehicle cannot be driven.	Bad DESS system connection. Defective tether cord cap. Dirt or snow in tether cord cap. Defective DESS post.	Reinstall tether cord cap correctly over post. Use another programmed tether cord cap. Clean tether cord cap. Replace DESS post.
1 long beep per second.	Reverse is selected.	Vehicle can be driven in reverse.
3 short beeps per second. DESS/RER pilot lamp also blinks. Engine cannot reach pulley engagement speed. Vehicle cannot be driven.	Wrong tether cord cap is installed.	Install proper tether cord cap. Program key into ECM.
3 short beeps per second. Engine overheating pilot lamp also blinks.	Engine is overheating.	Stop engine immediately and allow to cool. Check cooling system.

Section 06 ENGINE MANAGEMENT (SDI)

Subsection 02 (DIAGNOSTIC PROCEDURES)

CODED SIGNALS	POSSIBLE CAUSE	REMEDY
1 long beep (2 seconds) every 15 minutes.	Low battery voltage.	Check battery and charging system.
4 short beeps every 2 minutes. Oil pilot lamp also lights up.	Low oil level on 2-TEC models.	Check oil level and replenish as soon as possible.

Many other codes use the engine pilot lamp and the beeper to indicate a problem. Refer to B.U.D.S. for possible causes and service actions.

P CODE	EMS PILOT LAMP	BEEPER	DESCRIPTION
P0106	OFF	OFF	Air pressure sensor voltage out of range.
P0337	OFF	OFF	No crankshaft signal detected.
P0336	OFF	OFF	High engine RPM detected.
P0339	OFF	OFF	Crankshaft signal fault.
P0654	OFF	OFF	Tachometer RPM signal shorted to battery.
P0654	OFF	OFF	Tachometer RPM signal open circuit or shorted to ground.
P0617	OFF	OFF	Starter relay shorted to battery.
P0616	OFF	OFF	Starter relay open circuit or shorted to ground.
P1670	OFF	OFF	Beeper shorted to battery.
P1671	OFF	OFF	Beeper open circuit or shorted to ground.
P0650	OFF	OFF	EMS pilot lamp shorted to battery.
P0650	OFF	OFF	EMS pilot lamp open circuit or shorted to ground.
P1675	OFF	OFF	Relay 2 shorted to battery.
P1676	OFF	OFF	Relay 2 open circuit or shorted to ground.
P1148	OFF	OFF	Safety fuel cut off detected.
P1611	OFF	OFF	P+ Test of ISC output signal failed.
P0513	OFF	OFF	Incorrect DESS® key.
P0601	OFF	OFF	Faulty module (software or hardware damaged).
P1677	OFF	OFF	Relay 3 shorted to battery.
P1678	OFF	OFF	Relay 3 open circuit or shorted to ground.
P1648	OFF	OFF	Battery lamp shorted to battery.
P1649	OFF	OFF	Battery lamp open circuit or shorted to ground.
P0655	OFF	OFF	Engine temperature lamp shorted to battery.
P0655	OFF	OFF	Engine temperature lamp open circuit or shorted to ground.
P1646	OFF	OFF	Engine temperature lamp shorted to battery.

Section 06 ENGINE MANAGEMENT (SDI)
Subsection 02 (DIAGNOSTIC PROCEDURES)

P CODE	EMS PILOT LAMP	BEEPER	DESCRIPTION
P1647	OFF	OFF	Engine temperature lamp open circuit or shorted to ground.
P0648	OFF	OFF	DESS lamp shorted to battery.
P0648	OFF	OFF	DESS lamp open circuit or shorted to ground.
P1654	OFF	OFF	Oil lamp shorted to battery.
P1658	OFF	OFF	Oil lamp open circuit or shorted to ground.
P0117	BLINK	OFF	Engine temperature sensor voltage too low.
P0118	BLINK	OFF	Engine temperature sensor voltage too high.
P0116	BLINK	OFF	Engine temperature sensor functional problem.
P0112	BLINK	OFF	Air temperature sensor voltage too low.
P0113	BLINK	OFF	Air temperature sensor voltage too high.
P0111	BLINK	OFF	Air temperature sensor functional problem.
P0427	BLINK	OFF	Exhaust temperature sensor voltage too low.
P0428	BLINK	OFF	Exhaust temperature sensor voltage too high.
P0426	BLINK	OFF	Exhaust temperature sensor functional problem.
P0107	BLINK	OFF	Air pressure sensor voltage too low.
P0108	BLINK	OFF	Air pressure sensor voltage too high.
P0608	BLINK	OFF	Sensor's power supply voltage too low.
P0608	BLINK	OFF	Sensor's power supply voltage too high.
P0232	BLINK	OFF	Fuel pump shorted to battery.
P0231	BLINK	OFF	Fuel pump open circuit or shorted to ground.
P0080	BLINK	OFF	RAVE® solenoid shorted to battery.
P0079	BLINK	OFF	RAVE® solenoid open circuit or shorted to ground.
P0326	BLINK	OFF	Knock sensor signal below minimum noise.
P1502	BLINK	OFF	TOPS functional problem.
P0351	BLINK	OFF	No ignition output cylinder # 1 (MAG for 2 cyl. engine).
P0352	BLINK	OFF	No ignition output cylinder # 2 (PTO for 2 cyl. engine).
P0262	BLINK	OFF	Injector cyl. # 1 OR outer MAG injector (2 cyl.), shorted to battery.
P0261	BLINK	OFF	Injector cyl. # 1 OR outer MAG injector (2 cyl.), open circuit or shorted to ground.
P0265	BLINK	OFF	Injector cyl. # 2 OR outer PTO injector (2 cyl.), shorted to battery.

Section 06 ENGINE MANAGEMENT (SDI)**Subsection 02 (DIAGNOSTIC PROCEDURES)**

P CODE	EMS PILOT LAMP	BEEPER	DESCRIPTION
P0264	BLINK	OFF	Injector cyl. # 2 OR outer PTO injector (2 cyl.), open circuit or shorted to ground.
P0268	BLINK	OFF	Injector cyl. # 3 OR inner MAG injector (2 cyl.), shorted to battery.
P0267	BLINK	OFF	Injector cyl. # 3 OR inner MAG injector (2 cyl.), open circuit or shorted to ground.
P0271	BLINK	OFF	Inner PTO injector shorted to battery.
P0270	BLINK	OFF	Inner PTO injector open circuit or shorted to ground.
P0122	BLINK	OFF	Throttle position sensor voltage too low.
P0123	BLINK	OFF	Throttle position sensor voltage too high.
P0601	BLINK	OFF	TPS learns unlikely or checksum fault.
P1102	BLINK	OFF	Throttle position sensor adaptation failure.
P1104	BLINK	OFF	Throttle position sensor adaptation canceled.
P1655	BLINK	OFF	DESS® shorted to battery.
P1656	BLINK	OFF	DESS® line shorted to ground.
P0604	BLINK	OFF	RAM fault.
P0605	BLINK	OFF	EEPROM fault.
P0602	BLINK	OFF	MPEM not coded.
P0605	BLINK	OFF	EEPROM checksum fault.
P0605	BLINK	OFF	Coding ID checksum fault.
P0605	BLINK	OFF	Coding checksum fault.
P0605	BLINK	OFF	Programming checksum fault.
P1549	BLINK	OFF	Very high exhaust temperature detected (1)
P0562	OFF	2 s beep/min.	Battery voltage too low.
P0563	BLINK	2 s beep/min.	Battery voltage too high.

(1) The beeper turns on when exhaust temperature is higher than 800°C (1472°F). When exhaust temperature reaches 850°C (1562°F), engine speed is limited to 5250 RPM.

VCK (VEHICLE COMMUNICATION KIT)

The VCK (Vehicle Communication Kit) (P/N 529 035 981) is the primary tool to diagnose engine management and fuel injection related problems.

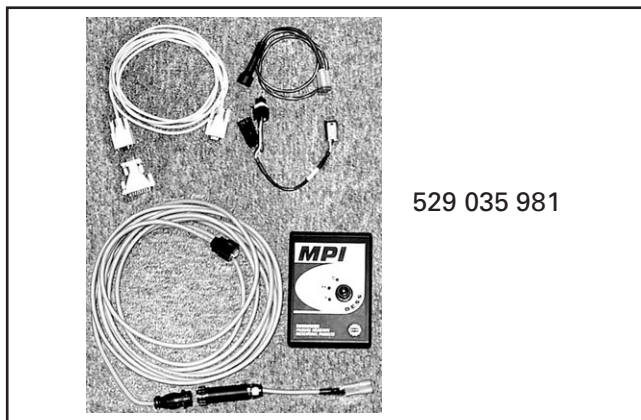

NOTE: The MPEM programmer does not work on SDI models.

Ensure to use the latest version of B.U.D.S. available on BOSSWeb.

B.U.D.S. (Bombardier Utility and Diagnostic Software) is designed to allow actuators, sensors and electronic equipments inspection, diagnostic options and reset such as the closed throttle.

For more information pertaining to the use of the software B.U.D.S., use its help which contains detailed information on its functions.

WARNING

If the computer you are using is connected to the power outlet, there is a potential risk of electrocution when working in contact with water. Be careful not to touch water while working with the VCK.

VCK Supply

The VCK (MPI box) can use the vehicle power for its supply. Four AA batteries or an AC/DC power supply can also be used. Make sure to respect MPI specification if a power supply is used.

Connecting VCK to Vehicle

Remove the 6 pin connector from the protective cap on the right side of the vehicle.

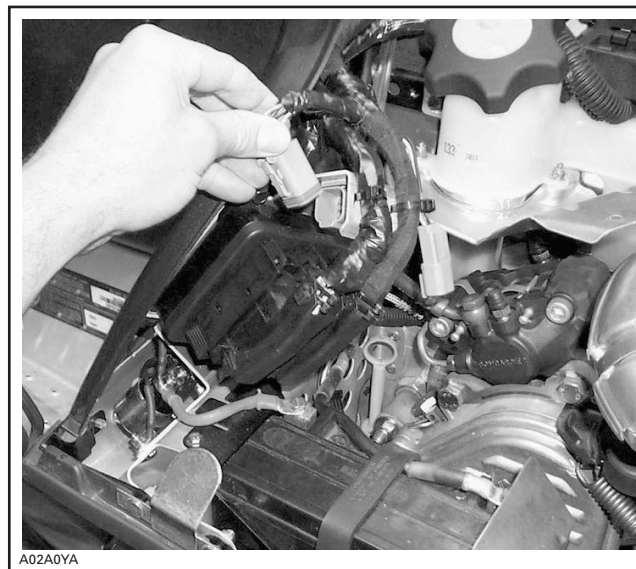

Connect supply harness (P/N 529 035 869), to vehicle 6-pin connector.

Connect the 6 pin diagnostic cable from VCK to supply harness.

NOTE: SDI engines already have a 12 V battery; they do not need any external 9 V or 12 V power to allow programming and troubleshooting. The use of the supply harness will keep the ECM ON. Not using it will make the ECM shuts-off after a few seconds.

Section 06 ENGINE MANAGEMENT (SDI)

Subsection 02 (DIAGNOSTIC PROCEDURES)

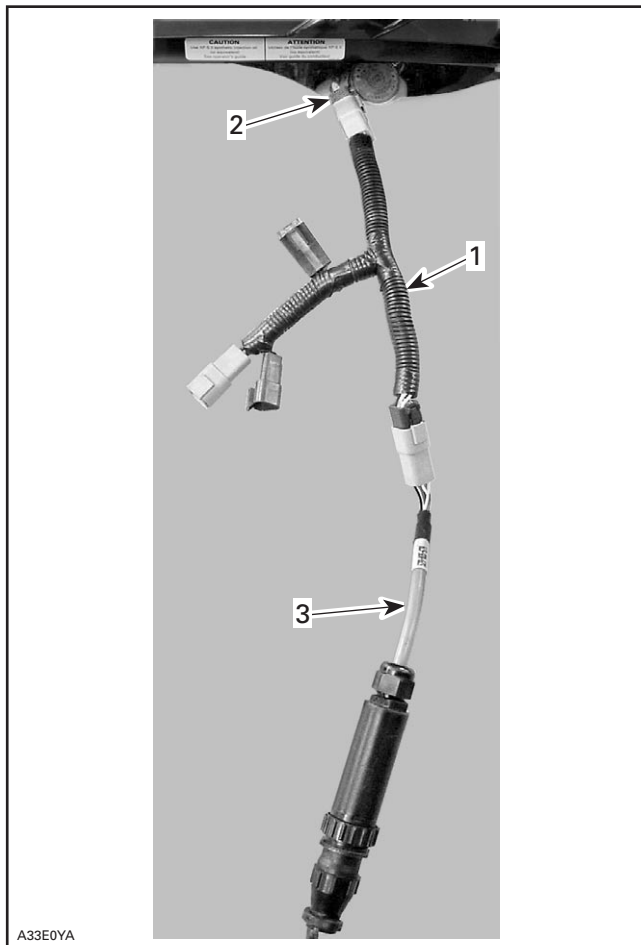

1. Supply harness
2. Vehicle 6-pin connector
3. VCK cable



CAUTION: Always use the proper supply harness and cables. Ensure to respect polarity when connecting cable clips to battery. Match RED cables together.

Set engine cut-out switch to OFF.

Install the GRAY diagnostic key (P/N 529 035 896) or any DESS cap onto the vehicle DESS post.

When using the software B.U.D.S., with the SDI:

- ensure that the protocol “KW2000” is properly selected in “MPI” under “Choose protocol”

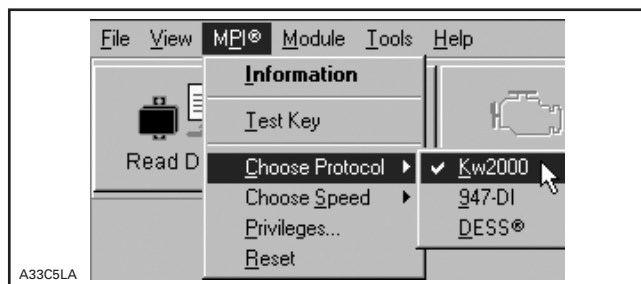

- ensure the status bar shows the KW2000 and the number 1 to the right. To communicate with the ECM, number 1 must be displayed.

Number 1 means that one module is connected with the PC.

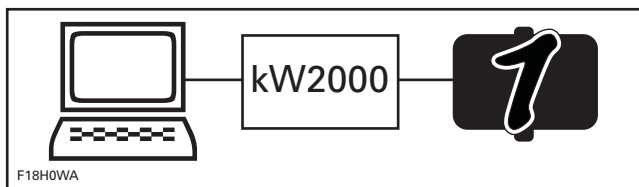

ONE MODULE IS CONNECTED

If an "X" is shown, this means that no communication between the MPI and the ECM is possible. In this case possible causes are:

- ECM is not powered-up
- wrong protocol is used
- bad connection between MPI and module.

Writing in ECM

When writing in ECM through B.U.D.S., there will be an "EMS Tracking" message that will say "Remove key from vehicle". When this occurs, remove the tether cord cap from its post and wait until the message disappears (it lasts approximately 15 seconds after tether cord cap removal).

2-TEC SYSTEM FAULT CODES

General

The faults registered in the ECM (engine control module) are kept when the battery is disconnected.

IMPORTANT: After a problem has been solved, ensure to clear the fault(s) in the ECM using the VCK. This will properly reset the appropriate counter(s). This will also record that the problem has been fixed in the ECM memory.

Many fault codes at the same time is likely to be burnt fuse(s).

For more information pertaining to the code faults (state, count, first, etc.) and report, refer to B.U.D.S. online help.

Supplemental Information

When using the service action suggested in the Fault section of B.U.D.S., the system circuits are referred to as DA-41, which means connector "A" on the ECM and the circuit D41.

TPS (Throttle Position Sensor) Faults

Faults which are reported in B.U.D.S. fall into two groups TPS faults and adaption faults. These are displayed on the B.U.D.S. system as TPS OUT OF RANGE and TPS ADAPTION FAILURE.

Section 06 ENGINE MANAGEMENT (SDI)

Subsection 02 (DIAGNOSTIC PROCEDURES)

TPS "OUT OF RANGE" Fault

It is caused by the sensor reading going out of its allowable range. This fault can occur during the whole range of movement of the throttle.

To diagnose this fully, it is recommended to operate the throttle through its full range. It is also recommended to release the throttle quickly as this may also reveal a fault that is intermittent.

POSSIBLE CAUSES	ACTION
Check if connector is disconnected from TPS	Reconnect.
Check if sensor is loose	Tighten sensor and reset Closed Throttle .
Inspect sensor for damage or corrosion	Replace sensor and reset Closed Throttle .
Inspect wiring (voltage test)	Repair.
Inspect wiring and sensor (resistance test)	If bad wiring, repair. If bad TPS, replace and reset Closed Throttle .
Test sensor operation (wear test)	Replace sensor and reset Closed Throttle .

TPS "ADAPTATION FAILURE" Fault

It is caused by the idle position moving out of an acceptable range.

Following problems can be caused by a TPS "Adaption Failure":

- Idle speed is out of range.
- Engine stops, when throttle is released quickly.
- Engine runs inconsistent in low partload or low RPM.

POSSIBLE CAUSES	ACTION
Sensor has been replaced and TPS closed position not reset	Reset Closed Throttle .
Throttle body has been replaced and TPS closed position not reset	Reset Closed Throttle .
ECM has been replaced and TPS closed position not reset	Reset Closed Throttle .
Throttle cable too tight	Adjust cable and reset Closed Throttle .
Sensor is loose	Tighten sensor and reset Closed Throttle .
Throttle bracket is loose	Fix and reset Closed Throttle .
Adjustment screw worn or loose	Adjust idle speed screw using B.U.D.S.

COMPONENT INSPECTION, REPLACEMENT AND ADJUSTMENT

SERVICE TOOLS

Description	Part Number	Page
Fluke 111	529 035 868	251
hose pinchers	295 000 076	254
pressure gauge.....	529 035 591	258
VCK (Vehicle Communication Kit).....	529 035 981	249, 259
wrench.....	529 035 899	259–260

SERVICE PRODUCTS

Description	Part Number	Page
anti-seize lubricant.....	293 800 070	272
dielectric grease	293 550 004	261
Loctite 5910.....	293 800 081	269, 272
pulley flange cleaner.....	413 711 809	255

GENERAL

Engine problems are not necessarily related to the engine management system.

It is important to ensure that the mechanical integrity of the engine and drive system are present:

- good transmission system operation
- good engine compression and properly operating mechanical components, no leaks etc.
- fuel pump connection and fuel lines without leaks.

Check the chart in TROUBLESHOOTING section to have an overview of problems and suggested solutions.

When replacing a component, always check its operation after installation.

FUEL SYSTEM

WARNING

The fuel system of a fuel injection system holds much more pressure than that of a carbureted snowmobile. Prior to disconnecting a hose or to removing a component from the fuel system, follow the recommendation described here. Pay attention that some hoses may have more than one clamp at their ends. Ensure to reinstall the same quantity of clamps at assembly.

- Use the VCK (Vehicle Communication Kit) (P/N 529 035 981) to release the fuel pressure in the system. Look in the **Activation** section of the software B.U.D.S. (ensure to use the latest version available on BOSSWeb).

Section 06 ENGINE MANAGEMENT (SDI)

Subsection 03 (COMPONENT INSPECTION, REPLACEMENT AND ADJUSTMENT)

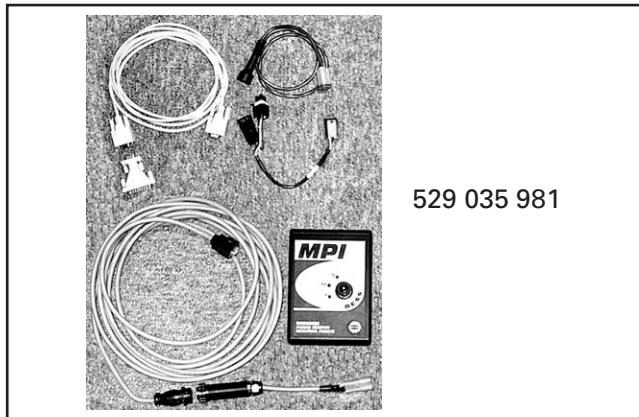

⚠ WARNING

Fuel lines remain under pressure at all times. Always proceed with care and use appropriate safety equipment when working on pressurized fuel system. Wear safety glasses and work in a well ventilated area. Proceed with care when removing/installing high pressure test equipment or disconnecting fuel line connections. Use the VCK to release fuel pressure prior to removing a hose. Cover the fuel line connection with an absorbent shop rag. Slowly disconnect the fuel hose to minimize spilling. Do not allow fuel to spill on hot engine parts and/or on electrical connectors. Wipe off any fuel spillage in the engine compartment. Fuel is flammable and explosive under certain conditions. Always disconnect battery or remove 30 A fuse prior to working on the fuel system. After performing a pressure test, release the pressure.

- Always disconnect battery properly or remove 30 A fuse prior to working on the fuel system. Refer to BATTERY section.

When the job is done, ensure that hoses from fuel rail going to fuel pump are properly secured in their supports. Then, pressurize the fuel system. Perform the fuel pressure test as explained in this section.

Properly reconnect the battery or reinstall 30 A fuse.

⚠ WARNING

Ensure to verify fuel line connections for damage and that NO fuel line is disconnected prior to installing the tether cord cap on the DESS post. Always perform the high pressure test if any component has been removed. The fuel pump is started and pressure quickly builds-up each time the tether cord cap is installed and the START/RER button is depressed (or rewind starter is pulled).

To check fuel rail for leaks, first pressurize the system then spray soapy water on all hose connections, regulators and injectors. Air bubbles will show the leaking area. Check also for leaking fuel or fuel odor.

⚠ WARNING

Never use a hose pincher on injection system high pressure hoses.

ELECTRICAL SYSTEM

It is important to check that the electrical system is functioning properly:

- battery
- capacitor (manual start models)
- fuses
- relays
- DESS
- ignition (spark)
- ground connections
- wiring connectors.

It is possible that a component seems to operate in static condition but in fact, it is defective. In this case, the best way to solve this problem is to remove the original part and replace it with one which is in good condition.

Never use a battery charger to substitute temporarily the battery, as it may cause the ECM (engine control module) to work erratically or not to work at all. Check related-circuit fuse solidity and condition with an ohmmeter. Visual inspection could lead to false results.

Section 06 ENGINE MANAGEMENT (SDI)

Subsection 03 (COMPONENT INSPECTION, REPLACEMENT AND ADJUSTMENT)

WARNING

All electrical actuators (injectors, fuel pump, ignition coils and starter solenoid) are continuously supplied by the battery when the start button is depressed or if engine is rotated (with the rewind starter). Always disconnect the tether cord cap and the battery prior to disconnecting any electric or electronic parts.

To perform verifications, a good quality multimeter such as Fluke 111 (P/N 529 035 868) should be used.

Pay particular attention to ensure that pins are not out of their connectors or out of shape. The troubleshooting procedures cover problems not resulting from one of these causes.

CAUTION: Ensure all terminals are properly crimped on wires and connector housings are properly fastened.

Before replacing an ECM, always check electrical connections. Make sure that they are very tight and they make good contact and that they are corrosion-free. Check if wiring harness shows any signs of scoring. Particularly check ECM ground connections. Ensure that contacts are good and clean. A “defective module” could possibly be repaired simply by unplugging and replugging the ECM. The voltage and current might be too weak to go through dirty wire pins. Check carefully if pins show signs of moisture, corrosion or if they look dull. Clean pins properly and then coat them prior to assembling as follows:

NOTE: Do not apply dielectric grease or other lubricant on the ECM connectors.

If the newly replaced ECM works, try the old one and recheck if it works.

Ensure that all electronic components are genuine – any modification on the wiring harness may lead to generate fault codes or bad operation.

NOTE: For diagnostics purposes, use Vehicle Communication Kit (VCK). See DIAGNOSTIC PROCEDURES for proper connectors/adaptors.

After a problem has been solved, ensure to clear the fault(s) in the ECM using the VCK. Refer to DIAGNOSTIC PROCEDURES subsection.

RESISTANCE MEASUREMENT

When measuring the resistance with an ohmmeter, all values are given for a temperature of 20°C (68°F). The resistance value of a resistance varies with the temperature. The resistance value for usual resistor or windings (such as injectors) **increases** as the temperature increases. However, some of our temperature sensors are NTC types (Negative Temperature Coefficient) and work the opposite which means that the resistance value **decreases** as the temperature increases. Take it into account when measuring at temperatures different from 20°C (68°F). Use this table for resistance variation relative to temperature for **temperature** sensors.

TEMPERATURE SENSOR TABLE					
TEMPERATURE		RESISTANCE (OHMS)			
°C	°F	ATS	EGTS	CTS FOR	
				GAUGE	ECM
- 40	- 40		169.7		72412
- 35	- 31				52637
- 30	- 22	28000			38681
- 25	- 13				28718
- 20	- 4	14500	185.1	733.8	21529
- 15	5			587.7	16288
- 10	14			474	12431
- 5	23			384.8	9565
0	32	5500	200.5	314.3	7418
5	41			258.4	5807
10	50			213.7	4582
15	59			177.7	3644
20	68	2500		148.7	2919
25	77		219.6	125	2355
30	86			105.6	1912
35	95			98.69	1562
40	104	1200		76.5	1284
45	113			65.54	1062
50	122		238.5	56.38	882.6
55	131			48.72	738.9
60	140	600		42.28	622

Section 06 ENGINE MANAGEMENT (SDI)

Subsection 03 (COMPONENT INSPECTION, REPLACEMENT AND ADJUSTMENT)

TEMPERATURE SENSOR TABLE					
TEMPERATURE		RESISTANCE (OHMS)			
°C	°F	ATS	EGTS	CTS FOR	
				GAUGE	ECM
65	149			36.82	526.3
70	158			32.19	447.5
75	167			28.24	382.3
80	176	320		24.86	328.1
85	185			21.95	282.8
90	194			19.45	244.8
95	203			17.28	212.8
100	212	180	275.9	15.4	185.6
105	221				162.4
110	230				142.7
115	239				125.9
120	248				111.5
125	257				99.02
130	266	90			88.26
135	275				78.93
140	284				70.81
145	293				63.71
150	302		312.7		57.49
200	392		349.0		
250	482		384.6		
300	572		419.7		
350	662		454.2		
400	752		488.1		
450	842		521.4		
500	932		554.1		
600	1112		617.8		
700	1292		679.2		
800	1472		738.2		
900	1652		794.9		
1000	1832		849.2		

The resistance value of a temperature sensor may test good at a certain temperature but it might be defective at other temperatures. If in doubt, try a new sensor.

Also remember this validates the operation of the sensor at room temperature. It does not validate the over temperature functionality. To test it, the sensor could be removed from the engine/air silencer and heated with a heat gun while it is still connected to the harness to see if the ECM will detect the high temperature condition and generate a fault code.

ENGINE CONNECTOR PIN-OUTS

Connector Position

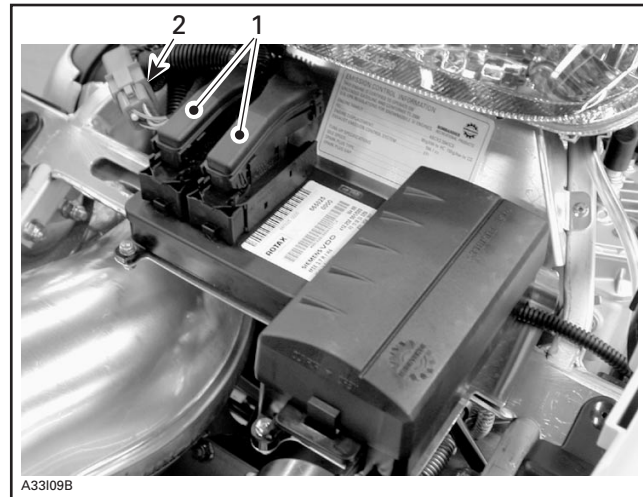

1. ECM connectors
2. Engine connector

ECM Connector

Use this diagram to locate the pin numbers on the ECM connector of the wiring harness when performing tests.

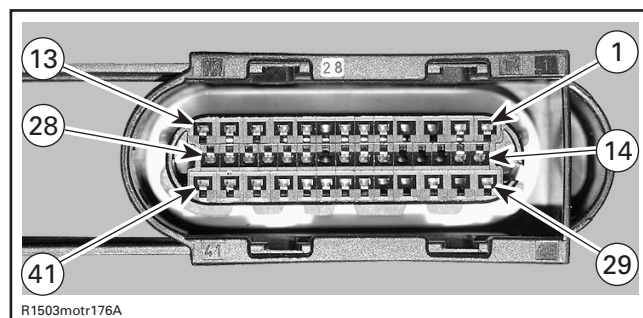

ECM CONNECTOR PIN-OUT (WIRING HARNESS SIDE)

Section 06 ENGINE MANAGEMENT (SDI)

Subsection 03 (COMPONENT INSPECTION, REPLACEMENT AND ADJUSTMENT)

CAUTION: Probe on top of terminal only. Do not try to probe inside terminal or to use a paper clip to probe inside terminal, it will damage the square-shaped terminal and this could lead to improper function of the engine management system.



A32CCPA

PROBE ONLY ON THE PIN NOZZLE OF FEMALE CONNECTOR

CAUTION: Do not disconnect the ECM connector needlessly. They are not designed to be disconnected/reconnected repeatedly.

Engine Connector

Use this illustration to locate the pin numbers on the engine connector of the wiring harness when performing tests.

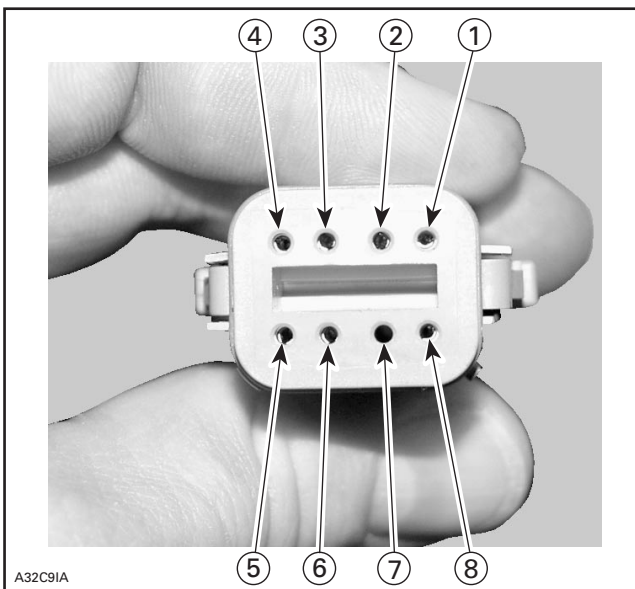

A32C9IA

ENGINE CONNECTOR PIN-OUT (WIRING HARNESS SIDE)

RELAY

Relay 2

Connect vehicle communication kit (VCK) and use B.U.D.S. software.

Energize **relay 2** from **Activation tab**.

Listen to or touch relay to feel it click.

If the relay does not work, disconnect the connector from the relay to test the input side.

Connect a voltmeter as indicated in the following table.

TEST PROBE (+)	TEST PROBE (-)
RED/GRAY wire	Battery ground

Battery voltage (12 V) should be read.

If voltage reads 12 V, check continuity of ORANGE/GREEN wire between relay connector and pin B-16 of ECM connector. If faulty, repair wire/connector. If wire/connectors test good, try a new ECM.

If voltage does not read 12 V, check continuity of wire on supply side of relay. If faulty, repair wire/connector. If wire/connectors test good, refer to ELECTRICAL SYSTEM to test output side or relay.

Section 06 ENGINE MANAGEMENT (SDI)

Subsection 03 (COMPONENT INSPECTION, REPLACEMENT AND ADJUSTMENT)

AIR INDUCTION SYSTEM

THROTTLE BODY

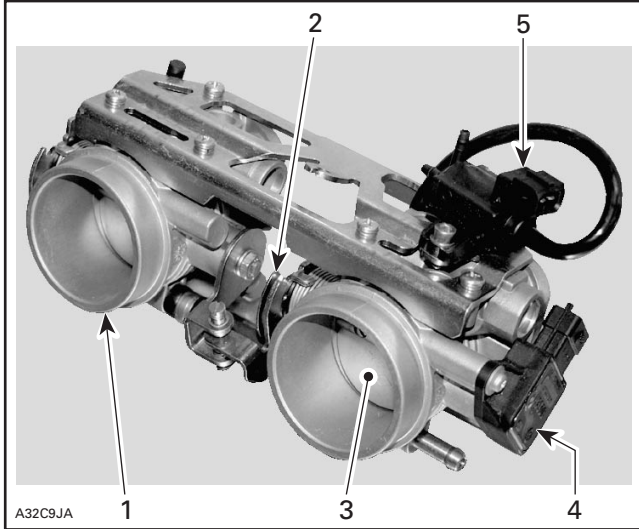

1. Throttle body
2. Throttle cable attachment
3. Throttle plate
4. TPS
5. E-RAVE solenoid

Mechanical Inspection

Check that the throttle plate moves freely and smoothly when depressing throttle lever.

IMPORTANT: The throttle body is designed to be tamper proof. Changing the zero position stop screw or synchronization screw or modifying them in any way will not increase performance but may cause poor startability and erratic idling.

Before replacing any part, check the following as these could be causing the fault. Perform the test while the engine is not running.

- Throttle cable adjustment too tight. Not returning fully to idle stop.
- Throttle body idle set screw is loose or worn.
- TPS is loose.
- Corroded or damaged wiring or connectors.
- Throttle body has been replaced and the **Closed Throttle** reset has not been performed.
- ECM has been replaced and the **Closed Throttle** reset has not been performed.

Electrical Inspection

Refer to THROTTLE POSITION SENSOR (TPS) in ELECTRONIC MANAGEMENT below.

Replacement

Removal

To remove the throttle body from engine, proceed as follows:

- Disconnect connectors from ATS (Air Temperature Sensor) and APS (Air Pressure Sensor).
- Disconnect air intake silencer from throttle body. Move boot away.
- Install hose pinchers (P/N 295 000 076) on inlet and outlet coolant hoses connected to throttle body.
- Remove clamps and hoses for throttle body heating from nipples.
- Disconnect connectors and hoses from E-RAVE solenoid and TPS.
- Disconnect throttle cable.
- Unscrew retaining clamps of throttle body.

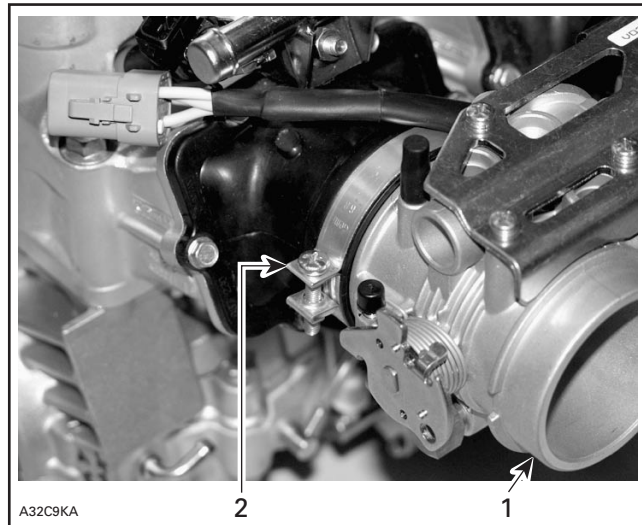

1. Throttle body
2. Clamp

- Slightly pull throttle body out.

Installation

Installation of the new throttle body is the reverse of the removal procedure. Pay attention to the following details.

Refill engine coolant. If an important quantity of coolant was spilled, bleed cooling system. Refer to COOLING SYSTEM section.

For TPS and E-RAVE solenoid replacement procedures, refer to the paragraph ELECTRONIC MANAGEMENT in this section.

Section 06 ENGINE MANAGEMENT (SDI)

Subsection 03 (COMPONENT INSPECTION, REPLACEMENT AND ADJUSTMENT)

Adjustment

Throttle Body Synchronization

CAUTION: It is not allowed to perform any change on the synchronization screw.

Before installation, clean throttle plates and bores with pulley flange cleaner (P/N 413 711 809).

NOTE: The throttle body is designed as a single part for both cylinders. No synchronization is required as it has already been done at the factory. However, proceed with throttle cable and closed TPS adjustments as described below.

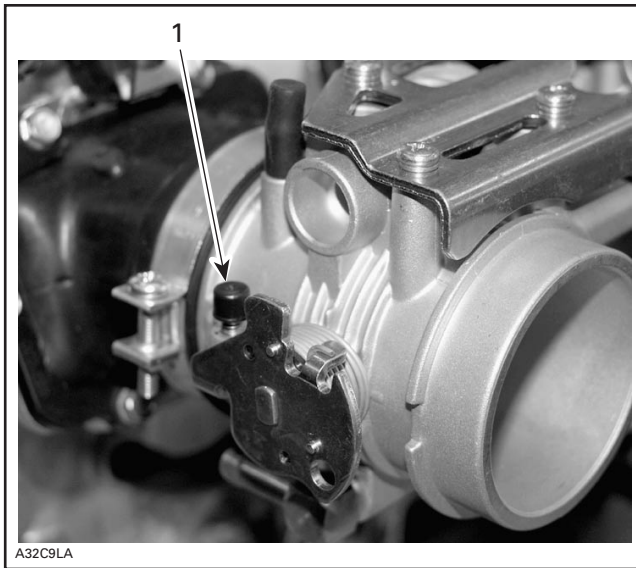

THROTTLE BODY

1. Zero position stopper screw

CAUTION: It is not allowed to perform any change on the zero position stopper screw.

The adjustment of the zero position stopper screw is optimized by the throttle body manufacturer and locked to prevent any modification.

CAUTION: Never attempt to adjust the zero position stopper screw (the capped one) or the idle speed adjustment would be impaired. Besides, no adjustment could be performed by the dealer nor the factory to correct the zero position stopper screw. The throttle body would need to be replaced.

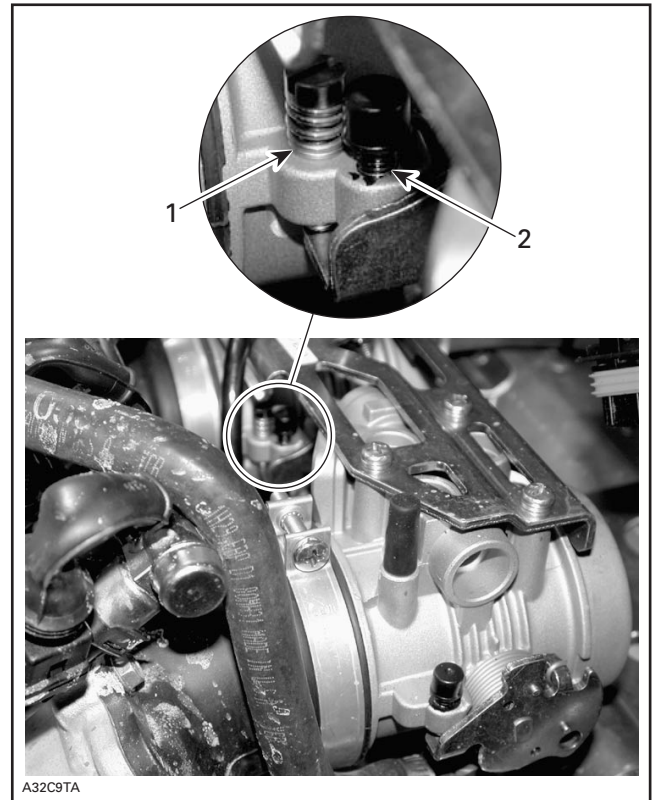

1. Idle speed screw
2. Zero position stopper screw

CAUTION: Do not alter or tamper with throttle cable adjustment or routing. It may cause poor startability and erratic idling.

The only screw that has to be adjusted is the idle speed screw and it has to be adjusted only with the closed throttle reset procedure or for high altitude application. This has to be done only if the ECM or throttle body are replaced or if screw has been tampered with by mistake. Refer to THROTTLE POSITION SENSOR (TPS) in ELECTRONIC MANAGEMENT below.

Throttle Cable Adjustment

Handlebar and throttle cable must be at their normal position.

Adjust top nut to have a small cable free-play at idle position.

Section 06 ENGINE MANAGEMENT (SDI)

Subsection 03 (COMPONENT INSPECTION, REPLACEMENT AND ADJUSTMENT)

Tighten bottom nut to 4.5 N•m (40 lbf•in).

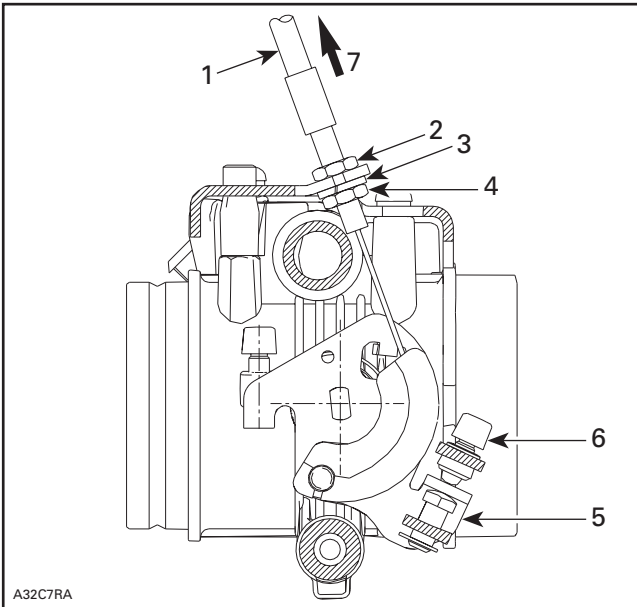

A32C7RA

1. Cable sheath
2. Upper nut
3. Lock washer
4. Lower nut
5. Throttle lever
6. Adjusting screw
7. Pull in this direction

Activate the throttle lever a few times. Make sure throttle cam of throttle body rests against idle speed screw without any tension on the cable.

Using the VCK with B.U.D.S., perform the wide open verification. In **Monitoring** tab check if throttle opening is within 82° to 86° when in wide open position on throttle lever.

Closed Throttle Reset

Perform the **Closed Throttle** reset as described in THROTTLE POSITION SENSOR (TPS) in ELECTRONIC MANAGEMENT below.

FUEL DELIVERY

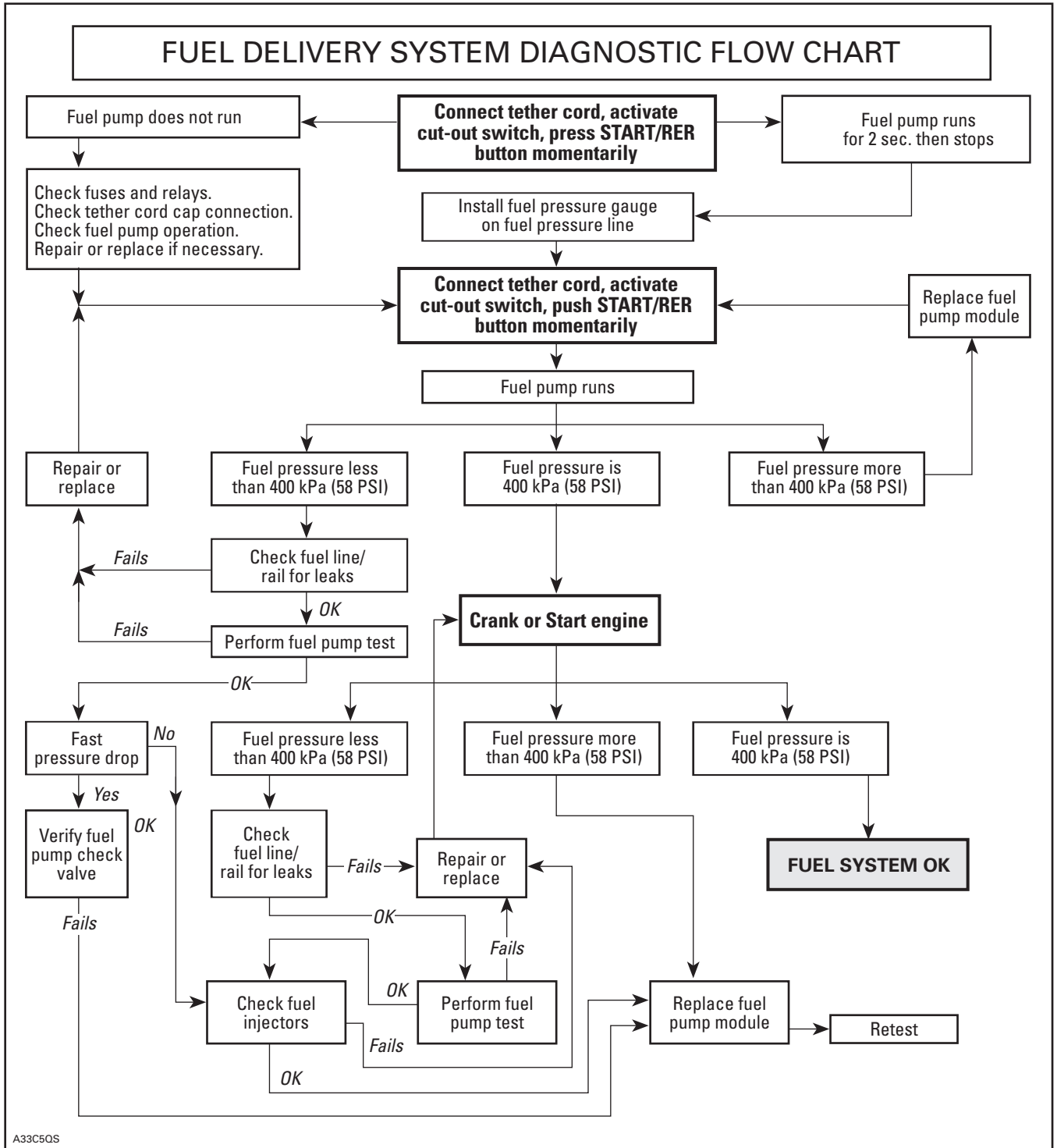

Section 06 ENGINE MANAGEMENT (SDI)

Subsection 03 (COMPONENT INSPECTION, REPLACEMENT AND ADJUSTMENT)

ELECTRIC FUEL PUMP

NOTE: For the diaphragm fuel pump, refer to FUEL SYSTEM.

Fuel Pressure Test

Before proceeding to the pressure test, ensure the battery is fully charged. Battery voltage must be over 12 volts.

Release the fuel pressure in the system using B.U.D.S. Refer to the **Activation** tab.

⚠ WARNING

The fuel hose may be under pressure. Cover the fuel line connection with an absorbent shop rag. Slowly disconnect the fuel hose to release the pressure. Wipe off any fuel spillage inside engine compartment.

The pressure test will show the available pressure at the fuel pump outlet. It validates the pressure regulator, the fuel pump and leaks in the system.

Ensure there is no leak from hoses and fittings. Repair any leak.

Ensure there is enough gas in fuel tank.

Disconnect outlet hose from fuel pump.

Remove plastic clip (P/N 275 500 429) from male fitting of pressure gauge (P/N 529 035 591).

Install the clip on male fitting of fuel rail inlet hose.



Remove tether cord cap. Depress START/RER button and observe fuel pressure. **Do not crank engine.** Repeat twice. Release pressure using B.U.D.S. between tests so that the gauge is "reset" to zero (0).

FUEL PRESSURE (WHEN DEPRESSING START BUTTON)

400 kPa (58 PSI)

Crank or start engine and observe fuel pressure. The fuel pressure should be the same as above.

If pressure is within limits, fuel pump and pressure regulator are working adequately.

A rapid pressure drop indicates leakage either from the fuel rail or from the fuel pump check valve. Check fuel rail for leaks. If it is not leaking then replace fuel pump.

A slow pressure drop indicates leakage either from the fuel injector or from the fuel pressure regulator. Check fuel injector for leaks (see below). If it is not leaking then replace fuel pump module.

Release fuel pressure in the system using B.U.D.S. Look in the **Activation** tab.

Remove pressure gauge and plastic clip from inlet hose. Reinstall fuel hose.

⚠ WARNING

Wipe off any fuel spillage in the engine compartment. Fuel is flammable and explosive under certain conditions. Always work in a well ventilated area.

Reinstall removed parts.

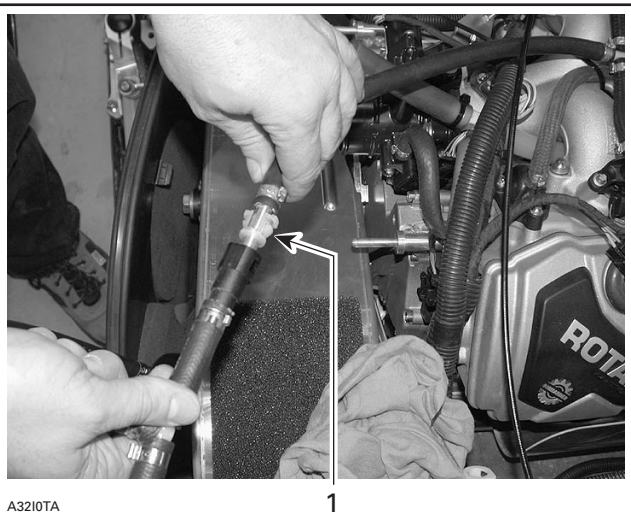

TYPICAL

1. Clip installed on male fitting of fuel rail inlet hose

Install fuel pressure gauge (P/N 529 035 591) between disconnected hoses (in-line installation).

Electrical Test

When depressing the START/STOP button, the fuel pump should run for 2 seconds to build up the pressure in the system.

If the pump does not work, disconnect the plug connector from the fuel pump.

Install a temporary connector to the fuel pump connector. Apply 12 V (+) on pin 2 and (-) on pin 1 to this test harness.

If pump does not run, replace the fuel pump module.

Otherwise, probe pin 2 and battery ground of fuel pump connector on vehicle harness side. When depressing the START/STOP button, you should read battery voltage for approximately 2 seconds (then, the voltage will drop). If battery voltage does not appear, the problem can be in fuse, relay(s), harness or in fuel pump connector. Repair or replace appropriate part.

Check continuity between pin 1 of the fuel pump connector on the vehicle harness side and terminal 29 of the ECM connector B. If there is no continuity the problem is in the harness. Otherwise, try a new ECM.

In-line Fuel Filter Replacement

Connect VCK (Vehicle Communication Kit) (P/N 529 035 981). Use B.U.D.S. to release fuel pressure.

Disconnect fuel filter line assembly from fuel rail and from fuel supply hose.

Install a new fuel filter line assembly.

Electric Fuel Pump Replacement

Removal

Remove seat. Connect VCK (Vehicle Communication Kit) (P/N 529 035 981). Use B.U.D.S. to release fuel pressure.

Drain fuel tank as much as possible.

Disconnect fuel supply hose from fuel filter line ass'y.

Disconnect fuel pump electrical connector.

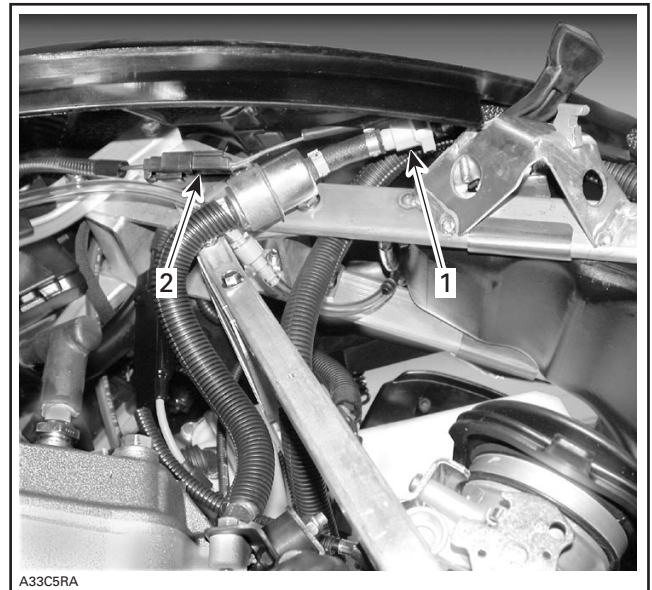

1. Disconnect hose from filter
2. Unplug connector

Disconnect hose coming from diaphragm pump.

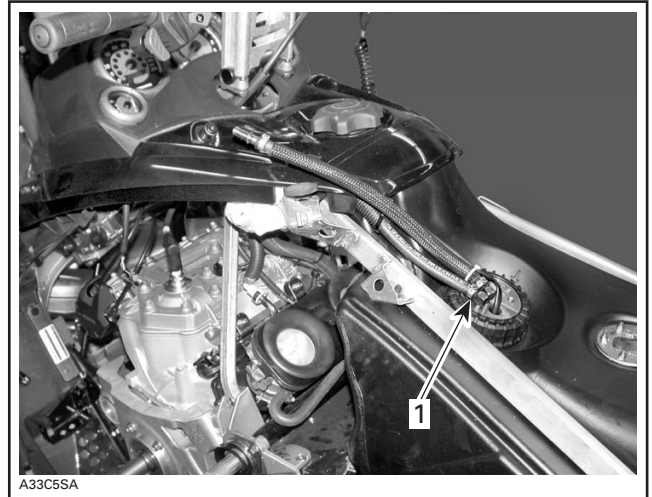

1. Disconnect hose

With two screwdrivers or a bent rod holding the flange, unscrew fuel pump nut using fuel pump nut wrench (P/N 529 035 899).

Section 06 ENGINE MANAGEMENT (SDI)

Subsection 03 (COMPONENT INSPECTION, REPLACEMENT AND ADJUSTMENT)

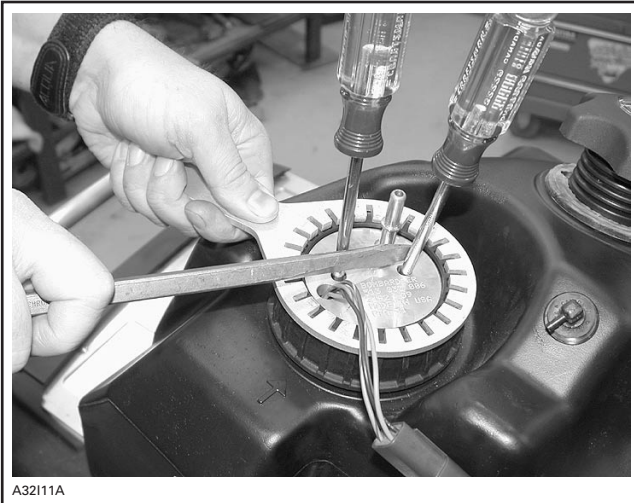

Disconnect pump electric connector.
Disconnect hose from pump.

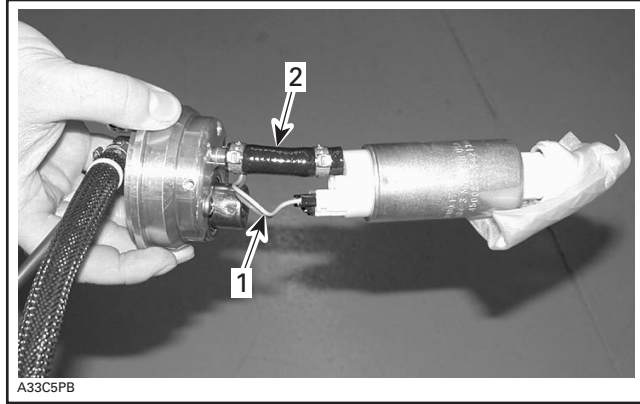

1. Electrical connect
2. Pump hose

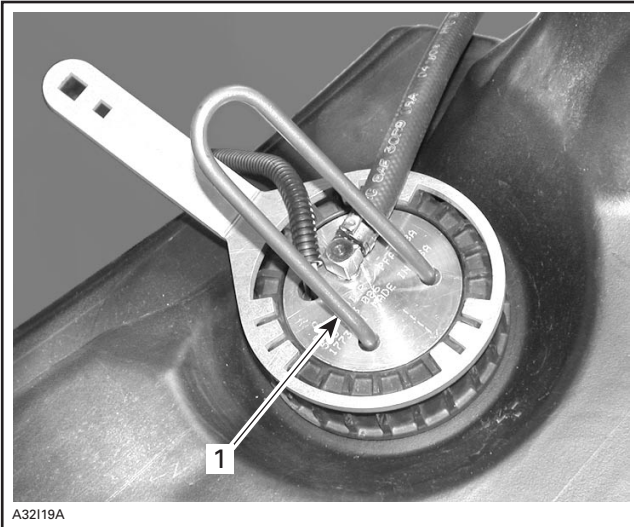

1. Bent rod

Remove fuel pump assembly.



Installation

For installation, reverse the removal process but pay attention to the following.

Install a new gasket.

Align the arrow on fuel pump assembly with the one on fuel tank. Keep arrows aligned when tightening fuel pump assembly.

Install a torque wrench perpendicularly (90°) to fuel pump nut wrench (P/N 529 035 899). Torque fuel pump nut to 27 - 30 N•m (20 - 22 lbf•ft).

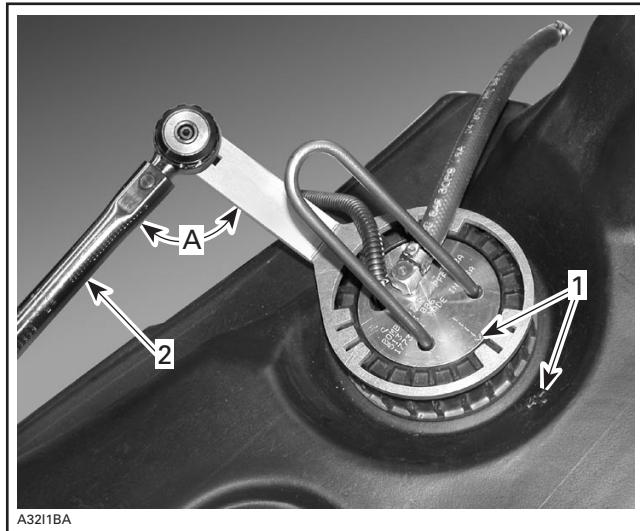

1. Arrows
 2. Torque wrench
- A. 90°

Section 06 ENGINE MANAGEMENT (SDI)

Subsection 03 (COMPONENT INSPECTION, REPLACEMENT AND ADJUSTMENT)

Use a new clamp to secure hose to fuel pump fitting.

CAUTION: Make sure that hose clamps are tight to avoid that they turn on their fittings.

Fuel Bleeding Procedure

Manual Start Models

When fuel tank is completely emptied, it may require up to 25-30 pull on rewind starter to fill the electric fuel pump reservoir. Filling the fuel tank will solve this problem. The fuel inside the fuel tank will flow through the bypass hole of the electric fuel pump reservoir.

Fuel Pressure Regulator Replacement

Remove fuel pump assembly as explained above.

Remove 2 screws retaining regulator to pump assembly flange.

Replace O-rings with new ones. Install them in pump assembly flange bore.

CAUTION: Regulator O-rings must be installed in pump assembly flange bore.

Reverse removal procedure for installation.

Install a new gasket, then reinstall fuel pump assembly as explained above.

FUEL RAIL

Pressure at fuel rail is supplied and controlled by the fuel pump module. Refer to FUEL PUMP for pressure test.

Fuel Rail Replacement

Removal

Release the fuel pressure in the system using B.U.D.S. Look in the **Activation** tab.

Disconnect fuel hose at the connector.

Wrap a rag around the hose end to prevent rail draining.

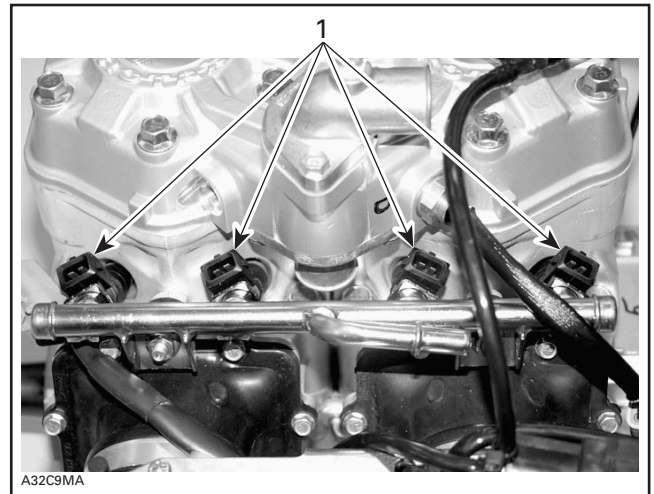

1. Fuel injectors

Disconnect wiring harness from the four fuel injectors.

Cut tie raps and remove the wiring harness from the fuel rail.

Unscrew rail retaining nuts.

Gently pull rail up by hand, working each side slightly at a time.

Pull rail out with fuel injectors.

If necessary remove fuel injectors as described below.

Installation

For installation, reverse the removal process but pay attention to the following.

Replace O-rings with new ones.

A thin film of injection oil should be applied to O-rings of fuel injectors to ease installation in cylinder.

Torque rail retaining nuts to 10 N•m (89 lbf•in).

Make sure that injector clips are well in place.

Add dielectric grease (P/N 293 550 004) to injector electrical connector.

When installing fuel line connector to the fuel rail, put some oil on the O-ring to ease installation.

WARNING

Perform a fuel pressure test and ensure that there is no leak. Refer to FUEL PUMP above. Run engine and check for leaks.

Section 06 ENGINE MANAGEMENT (SDI)

Subsection 03 (COMPONENT INSPECTION, REPLACEMENT AND ADJUSTMENT)

FUEL INJECTORS

Leakage Test and Fuel Flow Measurement

Preparation

First ensure fuel pressure is within specifications. The injectors and fuel rail have to be removed together from the engine. Do not remove injectors from the fuel rail. Refer to REMOVAL in FUEL RAIL REPLACEMENT as necessary.

To ensure continuous fuel availability for the electric fuel pump, first fill up fuel tank prior to performing the following tests. This is required because engine is not running to activate diaphragm fuel pump with the crankcase pulses.

Leakage Test

Place each injector in a clean bowl.

Install the tether cord cap on the DESS post and press the engine START/RER button to activate the fuel pump.

Check for fuel leakage from the injector nozzle. There should be less than 1 drop per minute. Perform the test for 2 minutes.

If not within specification, replace the fuel injector(s).

Fuel Injector Flow Measurement

Manual Start Models

To continuously supply the electric fuel pump for the tests, an external 12V battery is required. The small battery on the vehicle is not sufficient.

All Models

Use an appropriate burette graduated for 25 mL (.85 US oz). The Pirax® no 3075 (or equivalent) works fine.



Place injector inside top of burette.

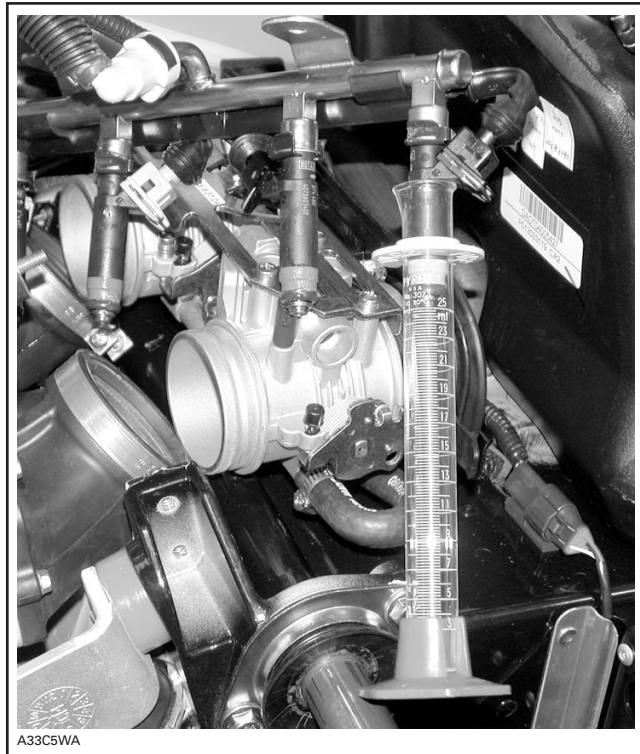

Connect vehicle communication kit (VCK) and use B.U.D.S. software. Install the tether cord cap on the DESS post and press the engine START/RER button to wake up the ECM.

Use appropriate wires and connect fuel pump directly to battery posts to continuously supply fuel pump.

Energize the appropriate injector under **Injector Flow Measurement** in **Activation** tab.

Section 06 ENGINE MANAGEMENT (SDI)

Subsection 03 (COMPONENT INSPECTION, REPLACEMENT AND ADJUSTMENT)

Energize each injector individually and measure the gas volume injected. Quantity of gas must be within the following specifications.

INJECTOR	VOLUME of FUEL mL (US oz)
Blue	16 ±1 (.54 ±.03)

If an injector is out of specification, retest it 2-3 times. If it still fails, replace it.

If all injectors fail, it is unlikely a failure of injectors. First ensure your reading from the burette is appropriate (pay attention to the division lines). Ensure fuel tank is full. Test for leaks in fuel system, fuel pump pressure, filter condition (in-line and in tank).

Properly reinstall parts.

Electrical Test

Voltage Test

Tether cord cap must be on DESS post.

Using the vehicle communication kit (VCK) with the B.U.D.S. software, energize the fuel injector from the **Activation** section.

If the injector does not work, disconnect the plug connector from the injector.

Install a temporary connector to the injector with wires long enough to make the connection outside the engine compartment and apply voltage (12 V) to this test harness.

This will validate the injector mechanical and electrical operation.

If it does not work, replace it. If it works, continue procedure.

Wake up ECM using START button and measure voltage between pin 1 (of injector on harness side) and battery ground.

If 12 V is read, disconnect connector A from the ECM and check continuity of circuit as per following table. If it is good, try a new ECM.

CIRCUIT NUMBER (ECM CONNECTOR «A»)	PIN 2 OF INJECTOR HARNESS
A-15	MAG external
A-33	PTO external
A-14	MAG internal
A-30	PTO internal

If it does not read 12 V, check the corresponding fuse(s), relay and continuity of circuit. If continuity is faulty, repair wiring harness.

Resistance Test

Disconnect the injector from the wiring harness and check the resistance of the injector itself.

The resistance should be around 14.5 Ω.

If resistance value is incorrect, replace the injector.

Reconnect the injector and disconnect the connector A from the ECM as well as the engine connector.

Using a multimeter, check resistance value between terminals as shown in the table below.

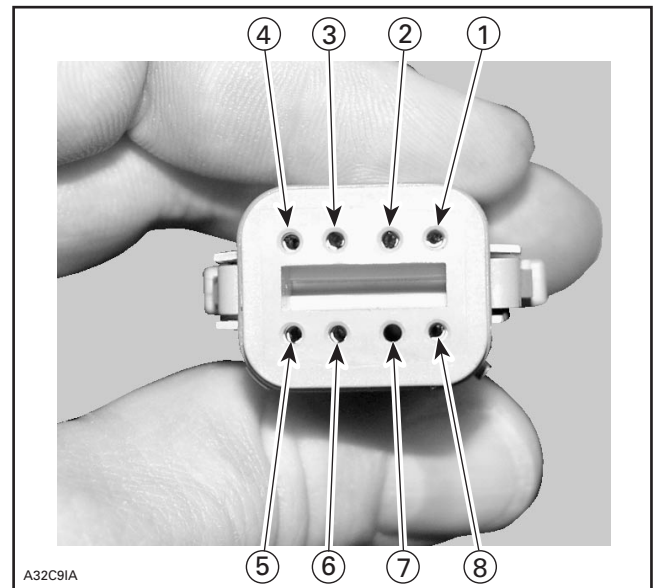

ENGINE CONNECTOR

Section 06 ENGINE MANAGEMENT (SDI)

Subsection 03 (COMPONENT INSPECTION, REPLACEMENT AND ADJUSTMENT)

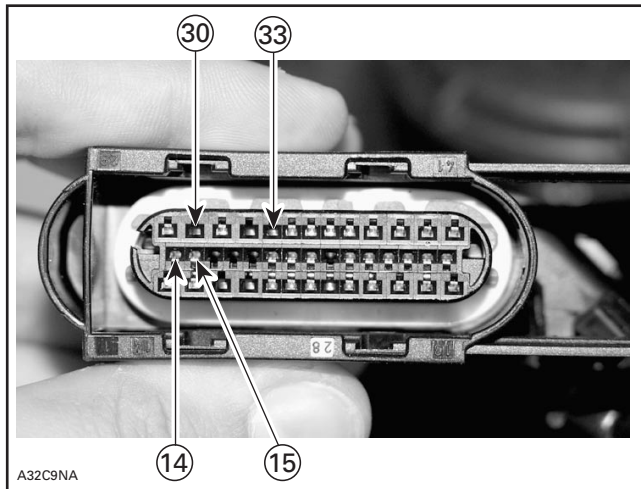

ECM CONNECTOR

COMPONENT	CONTACT LOCATION
Fuel injector, MAG external	4 (Engine Connector) and A-15 (ECM connector)
Fuel injector, MAG internal	3 (Engine Connector) and A-14 (ECM connector)
Fuel injector, MAG external	4 (Engine Connector) and A-33 (ECM connector)
Fuel injector, MAG internal	3 (Engine Connector) and A-30 (ECM connector)

The resistance should be around 14.5 Ω .

If resistance value is correct, check wiring of corresponding relay. If good, try a new ECM. Refer to ECM REPLACEMENT procedures elsewhere in this section.

If resistance value is incorrect, repair the wiring harness/connectors or replace the wiring harness between ECM connector and fuel injector.

Fuel Injector Replacement

Removal

Before removing the injectors, the fuel rail has to be removed from the engine. Refer to REMOVAL in FUEL RAIL REPLACEMENT for the procedure.

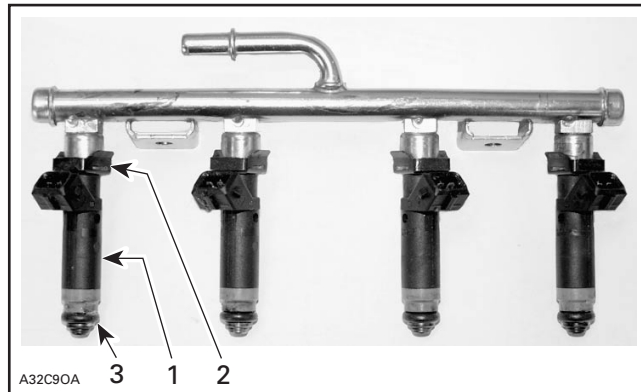

FUEL RAIL ASS'Y

1. Fuel injector
2. Injector clip
3. O-ring

Then remove the injector clip. Now the fuel injector can be easily pulled out of the fuel rail.

Installation

For the installation, reverse the removal procedure. Pay attention to the following details.

Insert injectors with your hand. Do not use any tool. Ensure clip and injector are properly installed.

Replace O-rings with new ones.

NOTE: A thin film of engine oil should be applied to O-rings to ease insertion in rail.

Torque rail retaining nuts to 10 N•m (89 lbf•in).

Attach injector wires with locking tie as shown in following photo.

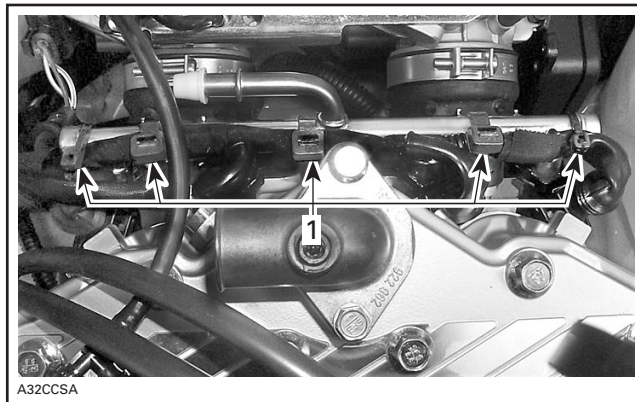

1. Locking ties

WARNING

Perform a fuel pressure test and ensure that there is no leak. Refer to FUEL PUMP above. Run engine and check for leaks.

ELECTRONIC MANAGEMENT

ECM REPLACEMENT

General

Prior to replacing a suspected ECM, ensure that all the recommendations in the general introduction of this section have been followed.

IMPORTANT: When the ECM is replaced, the tether cord cap(s) and the **Closed Throttle** must be reprogrammed/reset. Refer to their specific section for adjustment.

To allow transferring the previous recorded information from the old ECM to the new one, use the vehicle communication kit (VCK) with the B.U.D.S. software. Use **Replace ECM** in the **ECM** menu. Follow instructions provided by the help system.

NOTE: If the old ECM can still communicate, it must be read inside B.U.D.S. prior to removing it from the vehicle to carry vehicle information and history to the new ECM.

ECM Replacement

Disconnect battery cables.

⚠ WARNING

Battery BLACK (-) cable must always be disconnected first and connected last.

Disconnect both connectors from ECM.

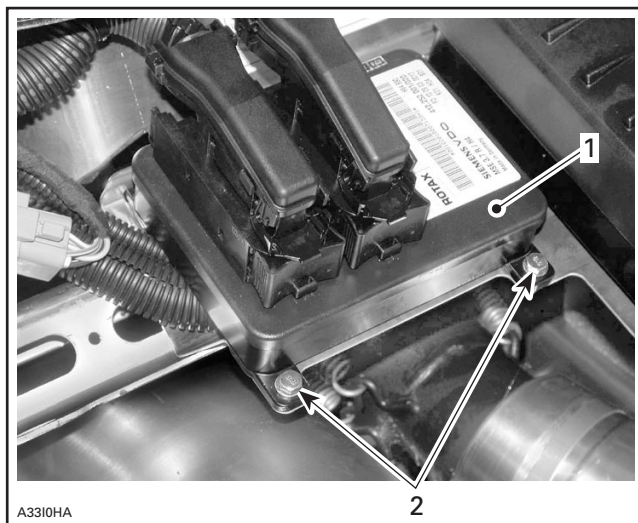

1. ECM
2. Retaining screws

Unscrew all retaining screws and remove the engine ECM from its support.

Install the new ECM to the support.

Reconnect ECM connectors to ECM, and then battery cables.

Transfer the data from the previous ECM to the new one using B.U.D.S. then proceed with the required resets and reprogram tether cord cap(s), if you were unable to transfer the data.

NOTE: If data cannot be transferred, manually enter information in **Vehicle** tab.

After performing the required resets, ensure to clear all faults from the newly replaced ECM.

Start the engine and increase engine speed above 6000 RPM to be sure no fault appears.

ENGINE WIRING HARNESS

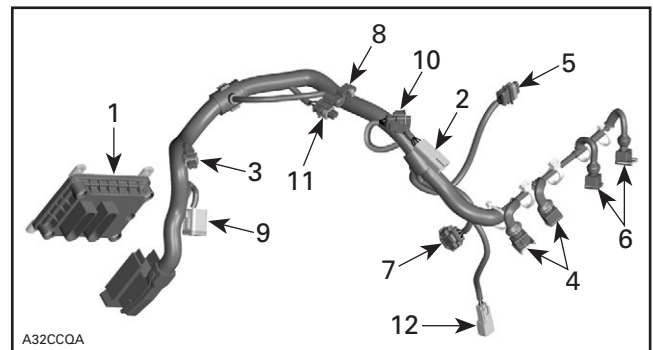

1. ECM
2. CTS connector
3. EGTS connector
4. Fuel injector connector (cylinder MAG side)
5. Ignition coil connector
6. Fuel injector connector (cylinder PTO side)
7. TPS connector
8. ATS connector
9. Engine connector
10. APS connector
11. KS connector
12. CPS connector

Resistance Test

Check continuity of the circuits according to the wiring diagram in the WIRING DIAGRAMS section of this manual.

If wiring harness is good, check the respective sensor/actuator as described in this section.

Otherwise, repair the connectors, replace the wiring harness or the ECM as diagnosed.

Section 06 ENGINE MANAGEMENT (SDI)

Subsection 03 (COMPONENT INSPECTION, REPLACEMENT AND ADJUSTMENT)

Removal

Remove air intake silencer.

Disconnect the wiring harness from all sensors/actuators.

Disconnect the connector from the ECM.

Cut all locking tie which are holding the wiring harness in position.

Remove complete wiring harness.

Installation

First connect the connector A to the ECM and the engine connector to the vehicle wiring harness.

Reconnect the wiring harness to all sensors/actuators and reinstall all locking tie that have been removed.

Install all remaining parts, which have been removed.

THROTTLE POSITION SENSOR (TPS)

General

The throttle position sensor (TPS) is a potentiometer that sends a signal to the ECM which is proportional to the throttle shaft angle.

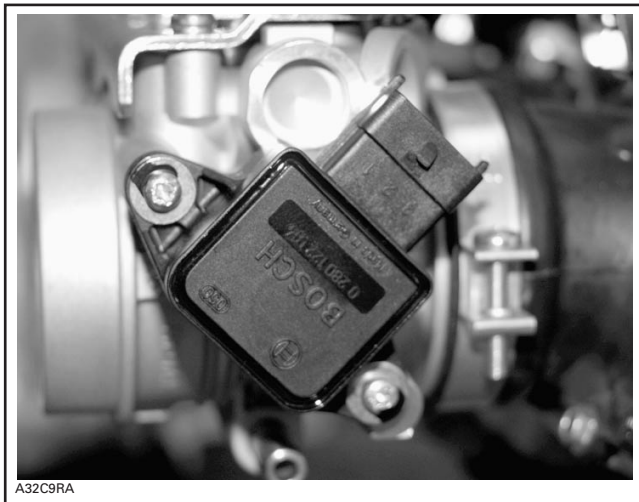

THROTTLE POSITION SENSOR (TPS)

IMPORTANT: Prior to testing the TPS, ensure that mechanical components/adjustments are adequate according to THROTTLE BODY in AIR INDUCTION SYSTEM above.

The ECM may generate several fault codes pertaining to the TPS. Refer to SYSTEM FAULT CODES in DIAGNOSTIC PROCEDURES section for more information.

Wear Test

While engine is not running, activate throttle and pay attention for smooth operation without physical stops of the cable.

Using the vehicle communication kit (VCK) with the B.U.D.S. software, use the **Throttle Opening** display under **Monitoring**.

Slowly and regularly depress the throttle. Observe the needle movement. It must change gradually and regularly as you move the throttle. If the needle "sticks", bounces, suddenly drops or if any discrepancy between the throttle movement and the needle movement is noticed, it indicates a worn TPS that needs to be replaced.

Voltage Test

Check the voltage output from ECM to the throttle position sensor.

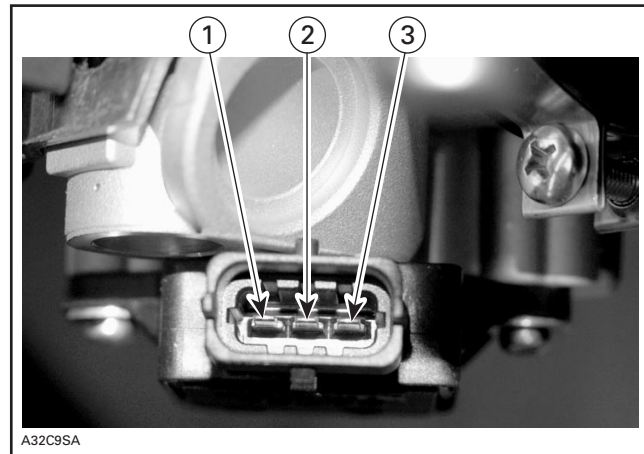

TPS

Disconnect plug connector from throttle position sensor. To unlock connector, insert a small screwdriver between the folded tab. To see the connector pin-out and its pin numbers, temporarily remove the connector shield joining the harness.

Install the tether cord cap, turn OFF engine cut-out switch and push START/REAR button momentarily to activate the ECM.

Connect a voltmeter between pin 1 and 2 in the wiring harness.

Voltage should be 5 V.

Section 06 ENGINE MANAGEMENT (SDI)

Subsection 03 (COMPONENT INSPECTION, REPLACEMENT AND ADJUSTMENT)

Check the continuity between pin 3 on wiring harness TPS connector and pin 24 on wiring harness ECM connector.

If tests are good, replace the TPS.

If voltage tests are not good, continue to check the resistance of the rest of the TPS circuit.

Resistance Test

Reconnect the TPS.

Disconnect the connector A from the ECM.

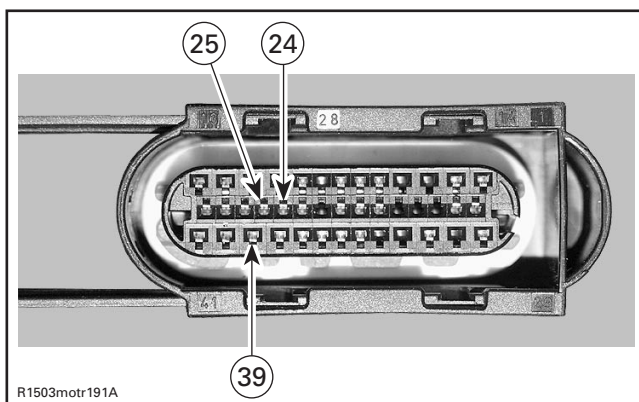

Using a multimeter, check resistance value as per the following table.

ECM CONNECTOR		THROTTLE IDLE POSITION	WIDE OPEN THROTTLE POSITION
PIN	PIN	Resistance Ω	
A-24	A-25	2500	1000
A-25	A-39	1600-2400	1600-2400
A-24	A-39	1000	2500

NOTE: The resistance value should change smoothly and proportionally to the throttle movement. Otherwise, replace TPS.

If resistance values are correct, try a new ECM. Refer to ECM REPLACEMENT procedures elsewhere in this section.

If resistance values are incorrect, replace TPS.

Replacement

Remove the throttle body as described above.

Loosen two screws retaining the TPS.

Remove TPS.

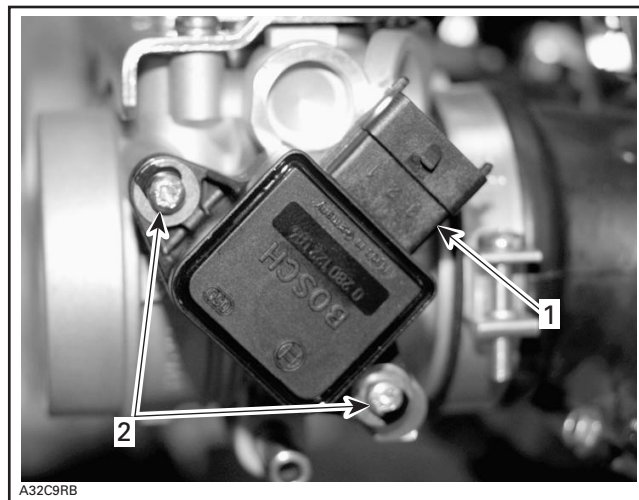

THROTTLE BODY

1. Throttle position sensor (TPS)
2. Screws

Install the new TPS.

Apply Loctite 243 on the TPS retaining screws, then torque to 3 N•m (27 lbf•in).

Reinstall remaining removed parts.

Proceed with the **Closed Throttle Reset**. See below.

Closed Throttle Reset

Ensure throttle body synchronization and throttle cable are properly adjusted prior to performing this setting.

NOTE: This operation performs a reset of the values in the ECM.

This reset is very important. The setting of the TPS will determine the basic parameters for all fuel mapping and several ECM calculations in idle speed control of the engine.

NOTE: Reset must be done each time the throttle position sensor (TPS) is loosened or removed or throttle body or ECM is replaced.

CAUTION: An improperly set TPS may lead to poor engine performance.

Use the vehicle communication kit (VCK) with the B.U.D.S. software to perform this adjustment.

Unscrew idle speed screw until the throttle body plate stop lever rest against its zero position stopper screw (capped screw). If necessary, loosen the throttle cable. Open throttle approximately one quarter then quickly release. Repeat 2 - 3 times to settle throttle plate.

Section 06 ENGINE MANAGEMENT (SDI)

Subsection 03 (COMPONENT INSPECTION, REPLACEMENT AND ADJUSTMENT)

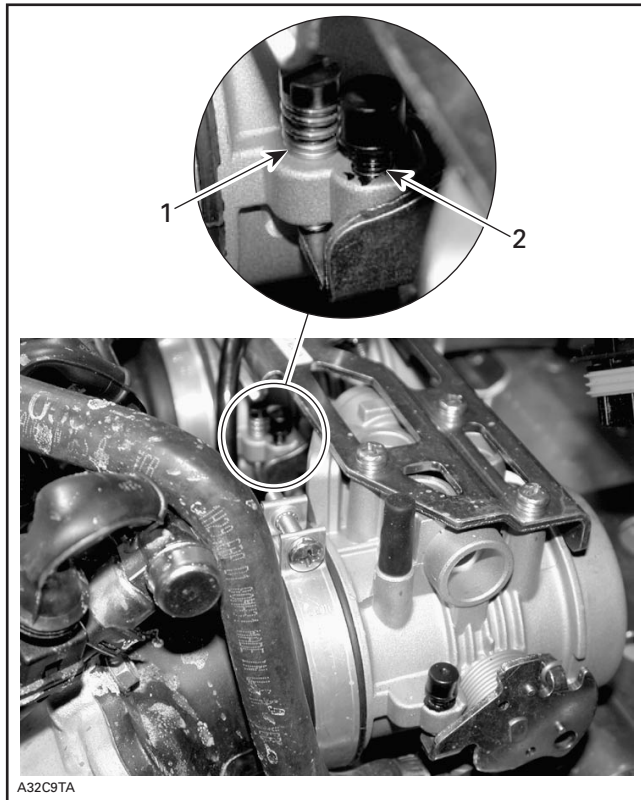

1. Idle speed screw
2. Zero position stopper screw

Push the **Reset** button in the **Setting** section of B.U.D.S.

Re-power up the ECM by pushing the START/RER button momentarily.

The throttle opening displayed in B.U.D.S. should be 0.00 (0.1 maximum).

If TPS is not within the allowed range while resetting the **Closed Throttle**, the ECM will generate a fault code and will not accept the setting.

Now, the idle speed screw has to be adjusted. To do this, screw in the idle speed screw until B.U.D.S. throttle opening displays value as per following table.

ENGINE	VALUE	
	AT SEA LEVEL	ABOVE 1800 m (6000 ft)
593 HO SDI	3.9° ±0.1	4.9° ±0.1

If throttle cable has been loosen during the procedure, adjust a throttle cable.

Start engine and make sure it operates normally through its full engine RPM range. If fault codes appear, refer to SYSTEM FAULT CODES in the DIAGNOSTIC PROCEDURES section for more information.

CRANKSHAFT POSITION SENSOR (CPS)

NOTE: The CPS is used for forward and reverse.

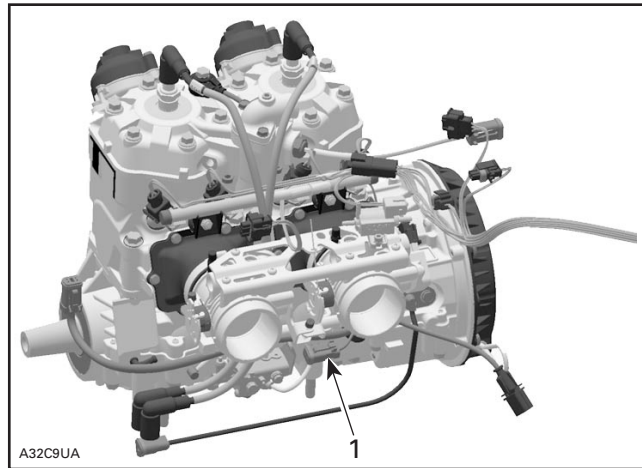

1. CPS connector

NOTE: Take into account that a CPS fault can be triggered by missing encoder wheel teeth. First check fault codes then check the teeth condition if necessary. See below.

Disconnect CPS wiring harness connector. Probe terminals coming from CPS while cranking engine. Voltage should be within 1-2 Vac. Otherwise, inspect wiring and replace CPS if wiring is good.

Resistance Test

Disconnect the CPS plug connector from the wiring harness and check the resistance of the sensor itself.

The resistance should be between 190 Ω and 300 Ω.

Otherwise, replace the CPS.

If resistance tests good, **reconnect** the CPS and disconnect the connector A on the ECM.

Section 06 ENGINE MANAGEMENT (SDI)

Subsection 03 (COMPONENT INSPECTION, REPLACEMENT AND ADJUSTMENT)

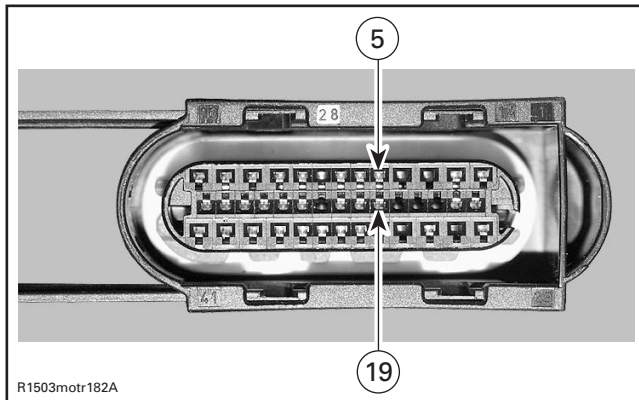

Using a multimeter, recheck resistance value between terminals 5 and 19.

If resistance value is correct, try a new ECM. Refer to ECM REPLACEMENT procedures elsewhere in this section.

If resistance value is incorrect, repair the connectors or replace the wiring harness between ECM connector and the CPS.

Replacement

Disconnect connectors and remove the rewind starter, then the magneto flywheel. Refer to MAGNETO SYSTEM.

Remove CPS.

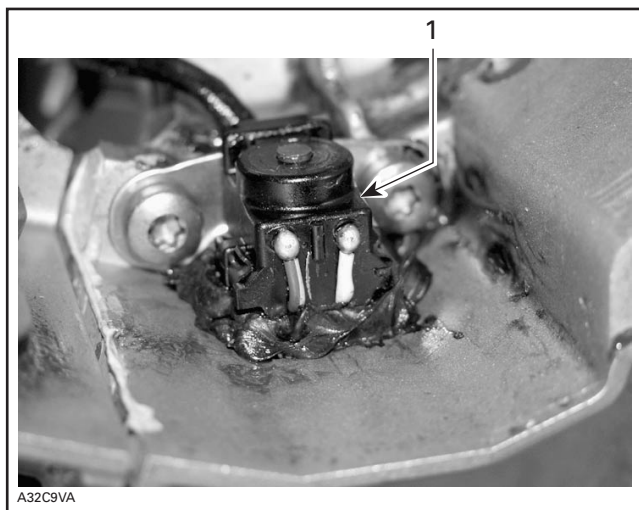

1. CPS inside crankcase

When installing new CPS apply Loctite 5910 (P/N 293 800 081) between CPS and crankcase.

Torque to 8 N•m (71 lbf•in).

Reinstall remaining removed parts.

AIR TEMPERATURE SENSOR (ATS)

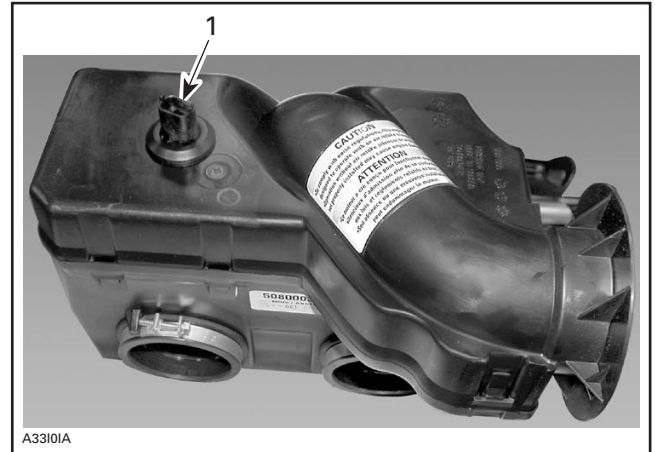

1. Air temperature sensor (ATS)

Resistance Test

Disconnect the plug connector from the ATS and check the resistance of the sensor itself.

Refer to TEMPERATURE SENSOR TABLE at the beginning of this section to find the corresponding resistance value for this sensor temperature.

If out of specification, replace the sensor.

If resistance tests good, **reconnect** the ATS and disconnect the connector A on the ECM.

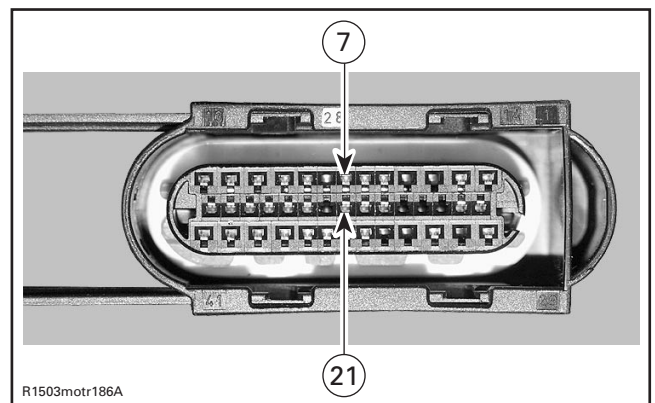

Using a multimeter, recheck resistance value between terminals 7 and 21.

If resistance value is correct, try a new ECM. Refer to ECM REPLACEMENT procedures elsewhere in this section.

Section 06 ENGINE MANAGEMENT (SDI)

Subsection 03 (COMPONENT INSPECTION, REPLACEMENT AND ADJUSTMENT)

If resistance value is incorrect, repair the connectors or replace the wiring harness between ECM connector and the ATS.

Replacement

Unplug ATS connector.

Pull the ATS out of the air intake silencer.

Spray soapy water on grommet. Install grommet on air intake silencer then push the sensor in place.

Reconnect it.

COOLANT TEMPERATURE SENSOR (CTS)

Resistance Test

Disconnect the plug connector from the CTS and check the resistance of the sensor itself.

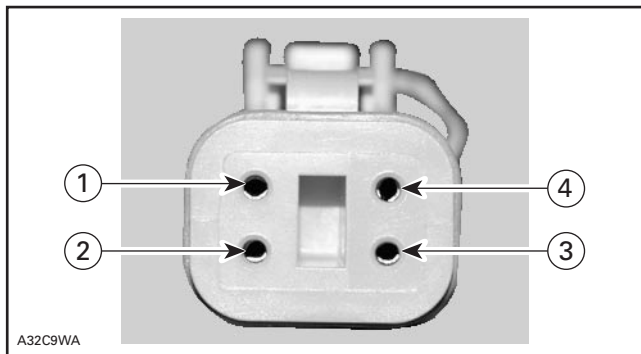

The resistance between pin 1 and 2 is used for temperature gauge.

Refer to TEMPERATURE SENSOR TABLE at the beginning of this section to find the corresponding resistance value for this sensor temperature.

If out of specification, replace the sensor.

The resistance between pin 3 and 4 is used for ECM.

Refer to TEMPERATURE SENSOR TABLE at the beginning of this section to find the corresponding resistance value for this sensor temperature.

If out of specification, replace the sensor.

If resistance tests good, **reconnect** the CTS and disconnect the connector A on the ECM as well as the engine connector.

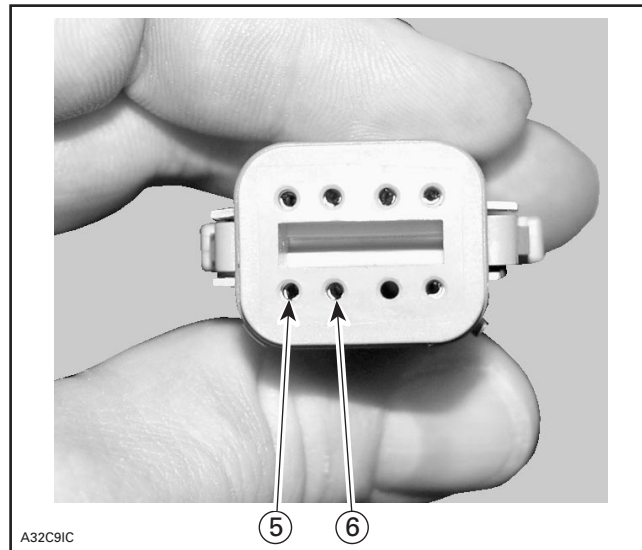

ENGINE CONNECTOR

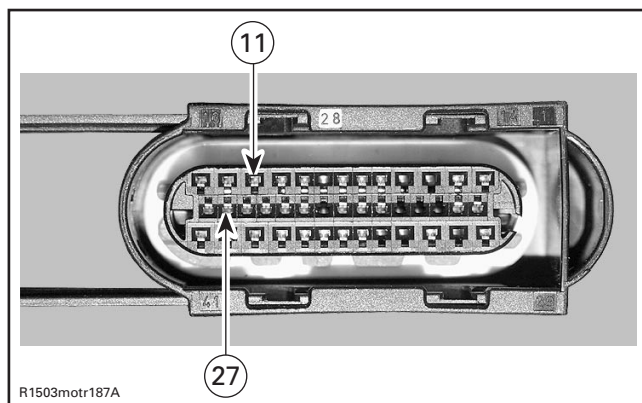

ECM CONNECTOR A

Using a multimeter, recheck resistance value between terminals 5 and 6 on engine connector. This resistance is used for temperature gauge.

Refer to TEMPERATURE SENSOR TABLE at the beginning of this section to find the corresponding resistance value for this sensor temperature.

Recheck also resistance value between terminals 11 and 27 on ECM connector A. This resistance is used for ECM.

Refer to TEMPERATURE SENSOR TABLE at the beginning of this section to find the corresponding resistance value for this sensor temperature.

If resistance value is correct, try a new ECM. Refer to ECM REPLACEMENT procedures elsewhere in this section.

Section 06 ENGINE MANAGEMENT (SDI)

Subsection 03 (COMPONENT INSPECTION, REPLACEMENT AND ADJUSTMENT)

If resistance value is incorrect, repair the connectors or replace the wiring harness between ECM connector and the CTS.

Replacement

Drain cooling system.

Disconnect CTS connector and remove CTS. Install the new CTS and torque to 12 N•m (106 lbf•in).

Reinstall remaining removed parts.

Refill engine coolant and bleed cooling system. Refer to LIQUID COOLING SYSTEM section.

AIR PRESSURE SENSOR (APS)

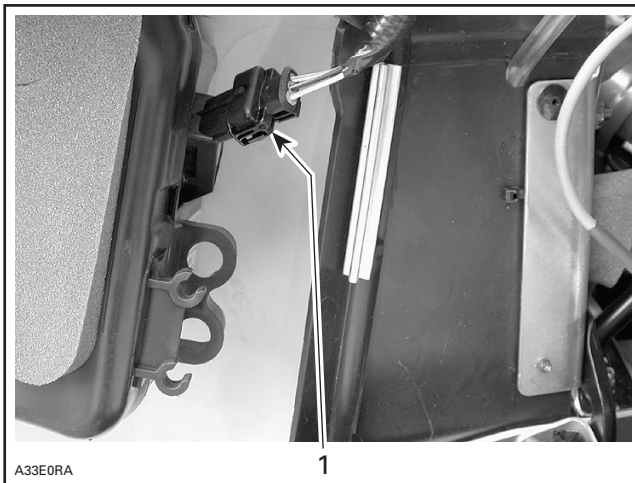

INSIDE LH SIDE PANEL
1. Air pressure sensor (APS)

Ensure sensor is correctly installed on air intake silencer. Otherwise, the APS could generate a fault code. Remove sensor and check for oil or dirt on its end and if problem persists, check the wiring harness. Perform the following tests.

Voltage Test

Check the voltage output from ECM to the APS.

Install the tether cord cap, turn OFF engine cut-out switch and push START/RER button momentarily to activate the ECM.

Disconnect plug connector from APS and connect a voltmeter between pin 1 and 2 of wiring harness.

Voltage should be 5 V.

Check the continuity between pin 3 on APS connector and pin 18 on ECM connector.

If tests are good, replace the APS.

If tests are not good, continue to check the continuity of the rest of the APS circuit on the harness.

Disconnect the connector A from the ECM.

Using a multimeter, check continuity of circuits as per following table.

CIRCUIT NUMBER (ECM CONNECTOR A)	APS CONNECTOR
A-3	PIN 1
A-4	PIN 2
A-18	PIN 3

If wiring harness is good, try a new ECM. Refer to ECM REPLACEMENT procedures elsewhere in this section.

Otherwise, repair the connectors or replace the wiring harness between ECM connector and the APS.

Replacement

Disconnect APS connector and remove the APS. The ATS is retained with a screw.

Install the new APS.

EXHAUST GAS TEMPERATURE SENSOR (EGTS)

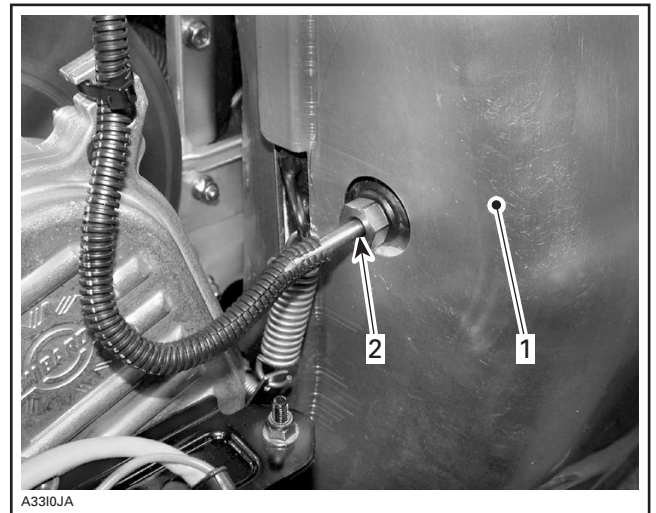

1. Muffler
2. Exhaust gas temperature sensor (EGTS)

Resistance Test

Disconnect the plug connector from the EGTS and check sensor resistance.

Section 06 ENGINE MANAGEMENT (SDI)

Subsection 03 (COMPONENT INSPECTION, REPLACEMENT AND ADJUSTMENT)

Refer to TEMPERATURE SENSOR TABLE at the beginning of this section to find the corresponding resistance value for this sensor temperature.

If out of specification, replace the sensor.

If resistance tests good, **reconnect** the EGTS and disconnect the connector A on the ECM.

Using a multimeter, recheck resistance value between terminals 10 and 26.

If resistance value is correct, try a new ECM. Refer to ECM REPLACEMENT procedures elsewhere in this section.

If resistance value is incorrect, repair the connector or replace the wiring harness between ECM connector and the EGTS.

Replacement

Disconnect EGTS connector and remove EGTS.

Apply anti-seize lubricant (P/N 293 800 070) over EGTS threads to prevent possible seizure.

Torque the new EGTS to 45 N•m (33 lbf•ft).

Replug connector.

KNOCK SENSOR (KS)

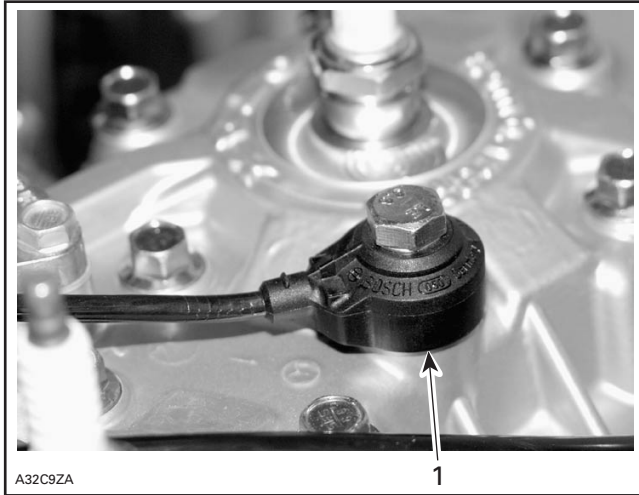

1. Knock sensor (KS)

Dynamic Test

Lift rear of vehicle off the ground and support it with a wide-base mechanical stand.

Using the vehicle communication kit (VCK) with the B.U.D.S. software, monitor the knock sensor using the Faults section.

Start the engine and bring engine RPM above 6000 RPM. If no fault code occurs, the knock sensor is good.

Otherwise, do the following.

Ensure sensor and head contact surfaces are clean and mounting bolt and washer are correct and properly torqued down.

Check the knock sensor circuit on wiring harness.

Disconnect the connector from knock sensor harness.

Disconnect connector A from the ECM and check continuity of circuit as per following table.

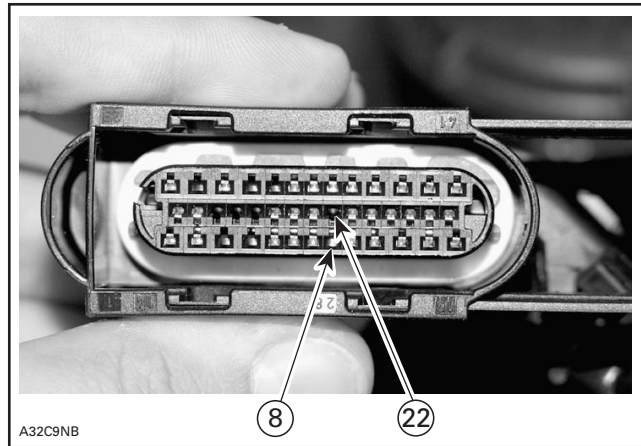

CIRCUIT NUMBER (ECM CONNECTOR A)	KS CONNECTOR
A-22	PIN 1
A-8	PIN 2

If test is not good, repair the connector or replace the wiring harness between ECM connector and knock sensor.

Replacement

Unscrew and remove knock sensor from cylinder head.

Clean contact surface, apply Loctite 5910 (P/N 293 800 081) on both contact surfaces on the knock sensor then install the new sensor.

CAUTION: Install screw and torque it within 10 minutes to prevent the sealant to dry before torquing. A dried sealant before torquing would impair the knock sensor operation.

Torque screw to 24 N•m (18 lbf•ft).

CAUTION: Improper torque might prevent sensor to work properly and lead engine to severe damage of internal components.

Replug connector.

E-RAVE SOLENOID

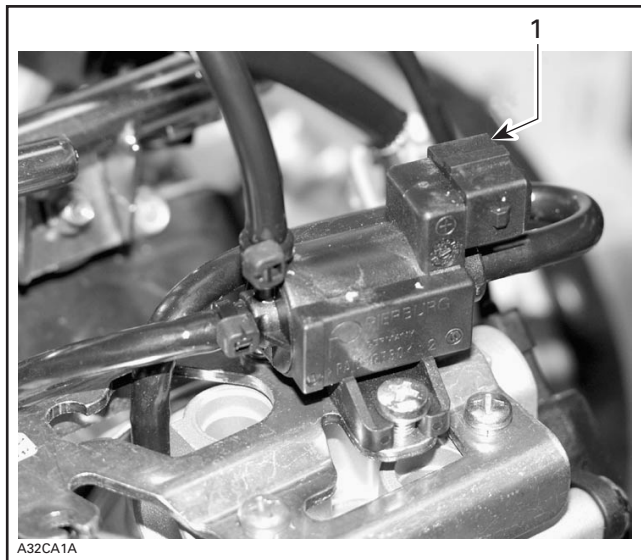

1. E-RAVE solenoid

Resistance Test

Disconnect the solenoid connector.

Check resistance value between both terminals of the solenoid.

The resistance value should be approximately 30 Ω .

Voltage Test

Install the tether cord cap and push the START/RER button momentarily to activate ECM.

Battery voltage should be present on VIOLET/GREY wire. If test fail, fuse may be blown.

Continuity Test

BROWN/WHITE wire must show continuity between solenoid connector and pin 15 on connector B from the ECM.

If test fail, repair connector or replace wiring harness between ECM connector and solenoid.

Replacement

Remove the air intake silencer. Unplug the solenoid connector and all hoses.

NOTE: Mark hose locations for installation.

Remove solenoid screws then the solenoid.

For installation, reverse the removal procedure.

DOUBLE IGNITION COIL

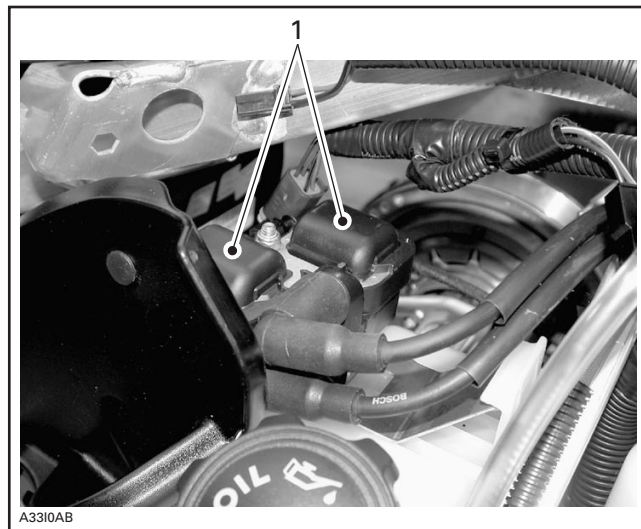

1. Ignition coil

NOTE: The ECM energizes the primary side of each ignition coil individually. It can detect if the double ignition coil is connected otherwise a trouble code will appear upon starting.

Using the vehicle communication kit (VCK) with the B.U.D.S. software, energize the ignition coil from the **Activation** section.

You should hear the spark occurring. In doubt, use an inductive spark tester or a sealed tester – available from after-market tool/equipment suppliers – to prevent spark occurring in the engine compartment. Otherwise, perform the following checks.

An ignition coil with good resistance measurement can still be faulty. Voltage leak can occur at high voltage level which is not detectable with an ohmmeter. Replacing the ignition coil may be necessary as a test.

Section 06 ENGINE MANAGEMENT (SDI)

Subsection 03 (COMPONENT INSPECTION, REPLACEMENT AND ADJUSTMENT)

Voltage Test

WARNING

When disconnecting coil from spark plug, always disconnect coil from main harness first. Never check for engine ignition spark from an open coil and/or spark plug in the engine compartment as spark may cause fuel vapor to ignite.

Disconnect the plug connector from the ignition coil and check the voltage supplied by the battery.

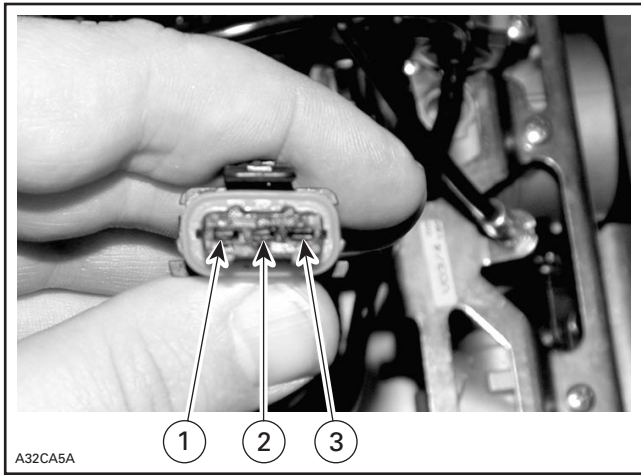

Install **tether cord cap** on the DESS post and push the START/RER button momentarily to activate the ECM.

Check voltage between terminal 2 of ignition coil connector on the wiring harness and battery ground.

Battery voltage should be present (approx. 12 V).

If 12 V is NOT read, check continuity between terminal 2 of ignition coil and the corresponding fuse. Otherwise repair wiring harness.

If 12 V is read, disconnect the connector A from the ECM and check the continuity of appropriate circuit 41 (cylinder 1) or 1 (cylinder 2) and of ignition coil connector, pin 3 and pin 1 respectively.

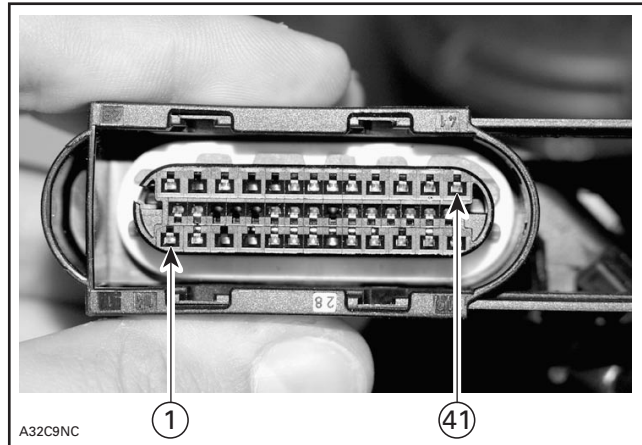

ECM CONNECTOR

If wiring harness is defective, repair the connector or replace the wiring harness between ECM connector and the ignition coil.

If wiring harness is good, test resistance of primary winding of ignition coil.

Resistance Test

Remove spark plug cables from ignition coil.

Using a multimeter, check the resistance of primary winding.

NOTE: The secondary winding can not be measured with an ohmmeter. Try a new double ignition coil if necessary.

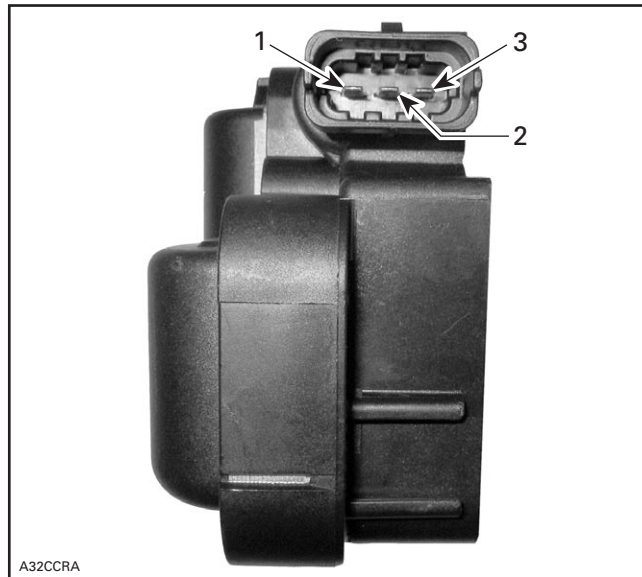

1. Terminal 1a
2. Terminal 15
3. Terminal 1b

Section 06 ENGINE MANAGEMENT (SDI)

Subsection 03 (COMPONENT INSPECTION, REPLACEMENT AND ADJUSTMENT)

For primary winding, check the resistance between terminal 15 and terminal 1a (cylinder 1) of the ignition coil and between terminal 15 and terminal 1b (cylinder 2) respectively.

The resistance should be between 0.40 and 1.15 Ω at 20°C (68°F).

If the resistance of one of both windings is not good, replace the ignition coil.

If the windings test good, try a new ECM.

WARNING

Always reconnect ignition coil cables at the same spark plugs where they come from. Otherwise, severe backfire may occur with possible damage to exhaust system components.

IGNITION TIMING

Refer to IGNITION SYSTEM section.

BATTERY

Manual Start Models

These models are equipped with a YT4L-BS type battery that requires a specific charging procedure at predelivery.

Battery Charge Testing

WARNING

Always wear safety glasses and charge in a ventilated area.
Never charge or boost battery while installed on vehicle.
Do not open the sealed caps during charging.
Do not place battery near open flame.

These sealed batteries have to be tested with a voltmeter.

Batteries with a voltage of 12.8 volts and above, no charge is required

Batteries with a voltage of 12.7 volts and below must be charged as follows:

BATTERY TYPE	STANDARD CHARGE	QUICK CHARGE
YT4L-BS	0.3 Amps/hour for 5 to 10 hours	3.0 Amps/hour for 30 min.

Electric Start Models

Refer to CHARGING SYSTEM section for the charging procedure of the battery.

CAPACITOR

Manual Start Models

WARNING

Capacitor may be charged. Once discharged, a transient recovery voltage may be generated in the capacitor after a while. Always discharge capacitor before servicing.

Removal

Remove the 30 A fuse.

Connect a test light to capacitor terminals during a complete minute to discharge capacitor.

WARNING

Do not short-circuit both capacitor terminals.

Disconnect capacitor terminals and unfasten capacitor.

Inspection

Visual Inspection

Check for pin holes in the pressure relief valve on top of capacitor. If any pin hole is present, discard capacitor.

Charge Hold Test

Connect a 12 V test lamp to capacitor terminals during a complete minute to discharge capacitor.

Connect a switch (in OFF position) between a 12 V battery positive post and the capacitor positive post. Connect the battery negative post to the capacitor negative post. Turn on the switch for 2 seconds. Disconnect the capacitor from the battery.

Note battery voltage.

Section 06 ENGINE MANAGEMENT (SDI)

Subsection 03 (COMPONENT INSPECTION, REPLACEMENT AND ADJUSTMENT)

WARNING

Always respect the polarity when connecting the capacitor.

Wait 5 minutes, then measure capacitor voltage. It must be within 1 V maximum of battery voltage. If in doubt, proceed with the following residual voltage test.

Residual Voltage Test

Connect a 12 V test lamp to capacitor terminals during a complete minute to discharge capacitor.

Connect a switch (in OFF position) between a 12 V battery positive post and the capacitor positive post. Connect the battery negative post to the capacitor negative post. Turn on the switch for 2 seconds. Disconnect the capacitor from the battery. Note battery voltage.

WARNING

Always respect the polarity when connecting the capacitor.

Connect a switch (in OFF position) and a 300 Ω 5 W resistor to the capacitor. Turn on the switch for 12 seconds \pm 1 second of discharge.

Residual voltage after 12 seconds \pm 1 second of discharge must be above 5 volts.

Installation

Connect a 12 V test lamp to capacitor terminals during a complete minute to discharge capacitor.

Make sure 30 A fuse is removed.

Install the capacitor.

Make sure to connect BLACK wire to negative terminal and RED/WHITE to positive terminal.

WARNING

Always respect the polarity when connecting the capacitor.

Install the 30 A fuse.

ENGINE START/RER SWITCH VERIFICATION

All Models

A quick operation test can be done using the vehicle communication kit (VCK) with the B.U.D.S. software, using the **Monitoring** section. Press the START/RER button and look at the START/RER button LED. It should turn on, indicating the starting system is working on the input side of the starting system (START/RER button, ECM and wiring). If so, you know now the problem is on the output side of the starting system (ECM output signal to starting solenoid, wiring harness going to the solenoid and starter motor. Otherwise, check the input side as follows.

Test corresponding fuse, relay and wiring.

Disconnect the two connectors of the steering harness.

Measure the resistance of the two wires on the small connector (BEIGE and BLACK/BROWN) for 0 Ω . Depress start button and the reading should change from 0 Ω to infinitely high.

Release the start button and measure the resistance between pin 2 (BEIGE wire) of the small connector and pin 6 (RED/BROWN wire) on the big connector for infinitely high resistance to 0 Ω while the start button is depressed.

WARNING

Always respect the wire position when connecting the switch. Refer to the wiring diagram.

Test continuity of circuit B-19. If it is good, try a new ECM. Otherwise, repair harness/connectors.

RER Operation

When RER works erratically or if engine idle slow down then engine stalls, do the following.

- Check engine compression. A low compression engine may result in RER working erratically making you think the problem is an electronic problem.

Section 06 ENGINE MANAGEMENT (SDI)

Subsection 03 (COMPONENT INSPECTION, REPLACEMENT AND ADJUSTMENT)

- Check piston condition. Remove exhaust system and reed valves on intake side. Verify piston condition through the intake and exhaust ports. Look for scoring on piston skirts. Scored piston skirts may result in RER working erratically making you think the problem is an electronic problem.

When it does not work at all, check wiring and START/RER switch as explained above. If everything is normal, try another ECM.

DESS POST VERIFICATION

If 2 short beeps are not heard when starting the engine, refer to DIAGNOSTIC PROCEDURES.

The following continuity tests can also be performed using an ohmmeter.

Disconnect DESS post wires.

Tether Cord Cap Removed

Connect test probes to post BLACK/GREEN and BLACK/WHITE wires. Measure resistance, there should be NO continuity (open circuit).

Connect one test probe to the WHITE/GREY wire and the other test probe to the switch top terminal. Measure resistance, it must be close to 0 ohm.

Connect one test probe to the BLACK/GREEN wire and the other test probe to the post ring. Measure resistance, it must be close to 0 ohm.

Tether Cord Cap on DESS Post

Connect test probes to switch BLACK/GREEN and BLACK/WHITE wires. Measure resistance, it must be close to 0 ohm.

IGNITION SYSTEM

SERVICE TOOLS

Description	Part Number	Page
9-volt adaptor.....	529 035 675	288
digital/inductive type tachometer	529 014 500	284, 287
MPEM programmer.....	529 035 878	288
supply harness.....	529 035 869	288
Vehicle Communication Kit (VCK)	529 035 981	287

SERVICE PRODUCTS

Description	Part Number	Page
antiseize lubricant.....	293 800 070	291

GENERAL

Ignition System Testing Sequence

In the case of ignition problems, check the following in the prescribed order until the problem can be solved.

- 1) Spark testing.
- 2) Electrical connectors.
- 3) Ignition switch.
- 4) DESS post or tether cut-out switch.
- 5) Engine cut-out switch.
- 6) Ignition coil.
- 7) Trigger coil.
- 8) MPEM voltage (liquid cooled models only).
- 9) High voltage coil (liquid cooled models only).
- 10) Relay
- 11) Beeper.

Testing Conditions

Voltage measurements are always taken upon vehicle starting. Readings when the engine is running will be higher than indicated range. Part temperature must be approximately 20 °C (68 °F) (room temperature), otherwise readings could be distorted.

Analysis of Readings

- Voltage Readings

When testing the different magneto components, it is important to take into consideration that readings vary according to the force applied onto the manual starter. It is therefore important to employ enough force upon each trial.

The reading must be 3 times within or above the range indicated in the corresponding table. If the reading is too low, the part is considered to be defective and must be replaced.

- Resistance Readings

Place multimeter selector switch to Ω in order to measure resistance. Readings must be within the indicated range. Otherwise, the part is considered to be defective and must be replaced.

CAUTION: When taking measurements, it is useless to try to start the vehicle since readings would then be distorted.

- Intermittent Ignition Problems

It is difficult to make a diagnostic in the case of intermittent ignition problems. Thus, problems occurring only when the engine operating temperature is normal must be checked in similar conditions.

Section 07 ELECTRICAL SYSTEM

Subsection 01 (IGNITION SYSTEM)

In most cases when problems are caused by temperature or vibrations, these can only be solved by replacing parts. Most problems cannot be detected when the engine is stopped.

- Multiple Problems

As a matter of fact, more than one component can be defective. As a result, if the problem remains although a part was replaced, start over the whole verification from the beginning in order to identify the other defective component.

Spark Testing

During this operation, it is important to use the snowmobile spark plug and not a new one. Bring the plug in contact with the engine. Pull rewind starter. If no spark is produced, replace the spark plug with a new one and do the test again.

For more information on spark plug condition, refer to SPARK PLUG further in this section.

Electrical Connector

Make sure that none of the connectors are disconnected.

Ignition Switch or Start/RER Button

Refer to STARTING SYSTEM.

DESS Post or Tether Cut-Out Switch

DESS Post

Liquid-Cooled Engines

DESS POST		
TEST	Open circuit	Continuity
TEST PROBES	BLACK/WHITE and BLACK/GREEN wires	BLACK/WHITE and BLACK/GREEN wires
RESISTANCE	O.L.	00.0 to 00.5 Ω
VOLTAGE	—	—
NOTE	DESS key removed	DESS key installed

If readings do not correspond to the above mentioned indications, replace post.

If none of these verifications are conclusive, the problem finds its source in the main wiring harness. Do the following.

NOTE: For the next step, no switch must be connected to the main wiring harness.

Disconnect all switches from the main wiring harness and check the continuity of each wire by connecting probes to the end of wires of the same color. Repeat with all other wires. It is important to mention that all wires of the same color within a given harness are connected together. These wires should therefore have a closed circuit. On the other hand, BLACK and BLACK/YELLOW wires must have an open circuit (O.L. M Ω).

Repair or replace if necessary.

Tether Cut-Out Switch

Fan-Cooled Engines

TETHER CUT-OUT SWITCH		
TEST	Open circuit	Continuity
TEST PROBES	BLACK/YELLOW and BLACK wires	BLACK/YELLOW and BLACK wires
RESISTANCE	O.L.	00.0 to 00.5 Ω
VOLTAGE	—	—
NOTE	Engine cut-out switch must be in RUN position	Engine cut-out switch must be in STOP position

If readings do not correspond to the above mentioned indications, replace switch.

If none of these verifications are conclusive, the problem finds its source in the main wiring harness. Do the following.

NOTE: For the next step, no switch must be connected to the main wiring harness.

Disconnect all switches from the main wiring harness and check the continuity of each wire by connecting probes to the end of wires of the same color. Repeat with all other wires. It is important to mention that all wires of the same color within a given harness are connected together. These wires should therefore have a closed circuit. On the other hand, BLACK and BLACK/YELLOW wires must have an open circuit (O.L. M Ω).

Repair or replace if necessary.

Engine Cut-Out Switch

Check the condition of engine cut-out switch.

Section 07 ELECTRICAL SYSTEM
Subsection 01 (IGNITION SYSTEM)

ENGINE CUT-OUT SWITCH		
TEST	Open circuit	Continuity
TEST PROBES	BLACK/YELLOW and BLACK wires	BLACK/YELLOW and BLACK wires
RESISTANCE	O.L.	00.0 to 00.5
VOLTAGE	—	—
NOTE	Engine cut-out switch must be in RUN position.	Engine cut-out switch must be in STOP position.

Ignition Coil

Disconnect housing between the magneto and the MPEM.

Compare readings with those appearing in the IGNITION COIL table.

During voltage testing, when manually starting the engine while the spark plug is installed, the engine will tend to accelerate beyond the compression point. This will result in higher magneto output. Always repeat the procedure 3 times.

IGNITION COIL				
FAN-COOLED ENGINES				
TEST	Output	Ground continuity	Secondary winding voltage	Cable resistance
TEST PROBES	RED and BLACK wires	BLACK wire and engine wires	BLACK wire and engine	Spark plug cable and cap
RESISTANCE	4.5 to 6.5 Ω	00.0 to 00.5 Ω	—	4.0 kΩ to 6.0 kΩ
VOLTAGE	7.0 to 15.0 Vac	—	.100 to .250 Vac	—
NOTE	—	Engine refers to the engine metal parts connected to the magneto housing.	The measurement must be taken on the spark plug cable (without the spark plug).	—

IGNITION COIL				
LIQUID-COOLED ENGINES				
TEST	Primary winding resistance	Secondary winding voltage	Secondary winding resistance spark plug wires and cap included	Secondary winding resistance spark plug wires removed
TEST PROBES	WHITE/BLUE and BLACK wires	On spark plug wire insulation and on engine	Between both spark plug caps	Male terminals of coil
RESISTANCE	00.2 to 0.5	—	14.5 kΩ to 23.5 kΩ	9.6 kΩ to 14.4 kΩ
VOLTAGE	—	1.5 to 2.5 Vdc	—	—
NOTE	Disconnect the ignition coil from the MPEM	Do not probe into spark plug cap with spark plug wire removed from spark plug.	Do not attempt to remove spark plug caps from the wires.	With spark plug wires removed from high voltage coil.

Trigger Coil

NOTE: For SDI engine, refer to ENGINE MANAGEMENT.

Check the resistance and the voltage for each trigger coil.

TRIGGER COIL				
LIQUID-COOLED ENGINES				
TEST	Continuity		Output	
	Trigger coil #1	Trigger coil #2	Trigger coil #1	Trigger coil #2
TEST PROBES	BLUE/YELLOW and WHITE/YELLOW wires	GREEN/YELLOW and GRAY/YELLOW wires	BLUE/YELLOW and WHITE/YELLOW wires	GREEN/YELLOW and GRAY/YELLOW wires
RESISTANCE	190 to 300 Ω	190 to 300 Ω	—	—
VOLTAGE	—	—	.200 to .350 Vdc	.200 to .350 Vdc
NOTE	—	—	While cranking engine.	While cranking engine.

Section 07 ELECTRICAL SYSTEM

Subsection 01 (IGNITION SYSTEM)

TRIGGER COIL				
FAN-COOLED ENGINES				
TEST	Continuity		Output	
TEST PROBES	Trigger coil #1	Trigger coil #2	Trigger coil #1	Trigger coil #2
	BLUE/YELLOW and WHITE/YELLOW wires		BLUE/YELLOW and WHITE/YELLOW wires	
RESISTANCE	160 to 180 Ω	160 to 180 Ω	—	—
VOLTAGE	—	—	.150 to .350 Vac	.150 to .350 Vac
NOTE	—	—	—	—

If a trigger coil is out of specification, replace it.

MPEM

NOTE: For **SDI and Power Tek engines**, refer to **ENGINE MANAGEMENT** for more information concerning the Engine Control Module (ECM).

When other components have been tested above and are good, the electronic module can be suspected. Ensure wiring and connectors are in good condition and perform the following tests prior to replacing the electronic module.

Disconnect the connector housing between module and high voltage coil.

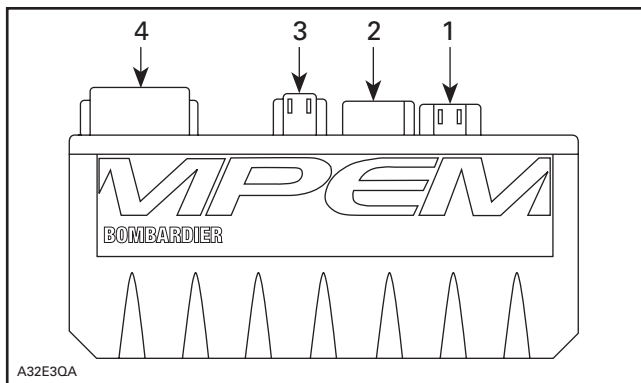

1. Trigger coil
2. Cooling temperature sensor
3. High tension coil
4. DESS, ignition and engine cut-out switches, DESS pilot lamp

Install probes on wires in accordance with the following table.

Activate the manual starter and check values indicated by the multimeter.

Repeat test 3 times.

MPEM ON VEHICLE WITH MANUAL STARTER			
TEST	Ground connection	Power from regulator	Voltage to ignition coil
TEST PROBES	BLACK wire and negative battery terminal or frame	RED/BLUE and BLACK wires	WHITE/BLUE and BLACK wires
RESISTANCE	00.0 to 00.5	—	—
VOLTAGE	—	3 to 5 Vdc	225.0 to 275.0 Vdc
NOTE	—	While cranking engine	With tether cap in place and engine cut-out switch in run position. While cranking engine.

MPEM ON VEHICLE WITH ELECTRIC STARTER				
TEST	Ground connection	Power from battery	Power from regulator	Voltage to ignition coil
TEST PROBES	BLACK and negative battery terminal or frame	RED/GREY and BLACK	RED/BROWN and BLACK	WHITE/BLUE and BLACK
RESISTANCE	00.0 to 00.5	—	—	—
VOLTAGE	—	Same as battery voltage	3 to 5 Vdc	225.0 to 275.0 Vdc
NOTE	—	Voltage always present.	While cranking engine.	With tether cap in place and engine cut-out switch in run position. While cranking engine.

Relay

Refer to **ACCESSORIES** or **ENGINE MANAGEMENT (Power Tek and SDI engines)**.

Beeper

Refer to **ACCESSORIES**.

IGNITION TIMING

Fan-Cooled Engines

If for any reason, ignition timing accuracy is suspected, it can be verified as follows.

Verifying Magneto Flywheel Timing Mark Position

Prior to checking the timing, it may be necessary to verify the position of the timing mark on the magneto flywheel, for the following reasons:

- To detect a missing or broken magneto flywheel Woodruff key which would allow a change of timing to occur, with eventual breakdown of the engine.
- To correctly locate and mark a timing mark on a new service magneto flywheel.
- To verify the correct location of the factory timing mark.
- To detect a wrong magneto flywheel corresponding to a different engine type.

To verify the position of the timing mark on the magneto flywheel, proceed as follows:

- Clean the area around the spark plugs, and remove them.
- Remove the rewind starter from the engine.
- Install the TDC gauge in the spark plug hole, (magneto/generator side) and adjust as follows:
 - Position the magneto flywheel at approximately TDC.

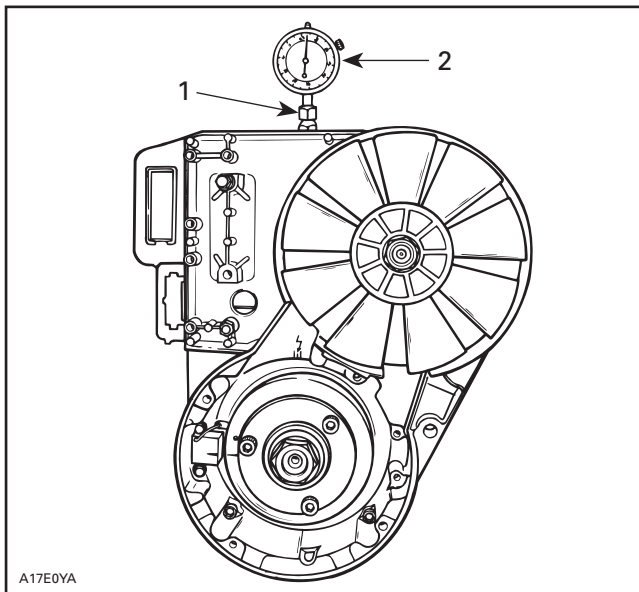

TYPICAL — INSTALLATION OF TDC GAUGE

1. Adaptor lock nut
2. Gauge on MAG side cylinder

- Assemble the gauge to the adaptor and tighten the roller lock nut. Do not tighten the adaptor lock nut.

- Screw the adaptor into the spark plug hole and tighten to prevent movement in the plug hole.
- Position the dial face toward the magneto/generator. Move the gauge down until the needle just begins to move, then move down a further 5 or 6 mm (approximately 1/4 in). Tighten adaptor lock nut by hand.
- Locate the piston TDC position as follows:
 - Slowly rotate the magneto flywheel back and forth across TDC while observing the needle. Note that the needle stops moving only as the piston is changing direction.
 - Rotate the dial face so that «0» is in line with the needle when it stops moving.
 - Again, slowly rotate the magneto flywheel back and forth across TDC and adjust the dial face to «0», until the needle always stops exactly at «0» before changing direction.
 - «0» now indicates exact TDC.
- Verify the position of the timing mark on the magneto flywheel as follows:

NOTE: When checking timing, certain procedures require that the magneto flywheel be turned in a clockwise direction, viewed facing the magneto/generator. If it is necessary to turn back (counterclockwise) for any reason, rotate the magneto flywheel at least one-quarter turn counterclockwise, and then rotate it clockwise. The last magneto flywheel movement when making a critical check must always be in a clockwise direction, to ensure that the slack in engine moving parts is taken-up.

- Rotate the magneto flywheel counterclockwise, one-quarter turn then carefully rotate it clockwise until the needle indicates the specified measurement. Refer to TECHNICAL DATA.
- Verify that the magneto flywheel mark perfectly aligns with the mark on the trigger coil, refer to illustration.
- If the marks do not align, check magneto flywheel and trigger coil part numbers and check Woodruff key condition. If all parts are the appropriate ones and if Woodruff key is in good condition, continue the procedure.

Section 07 ELECTRICAL SYSTEM

Subsection 01 (IGNITION SYSTEM)

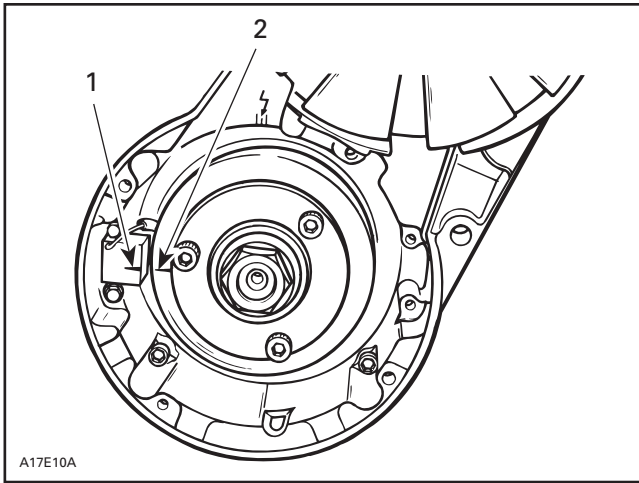

TYPICAL

1. Trigger coil mark
2. Magneto flywheel mark

NOTE: These marks cannot be used to check dynamic (with engine running) ignition timing with a timing light: a new mark must be scribed on magneto flywheel for this purpose.

- Scribe a new mark on magneto flywheel as follows.
 - Remove the fan cover from the engine.
 - Maintain magneto flywheel so that previous marks remain aligned.
 - Scribe or punch a mark on magneto flywheel so that it perfectly aligns with the arrow on crankcase, refer to illustration. This new timing mark should be used for future timing checks (dynamic timing).
 - Reinstall rewind starter.
 - Check the timing with a timing light.

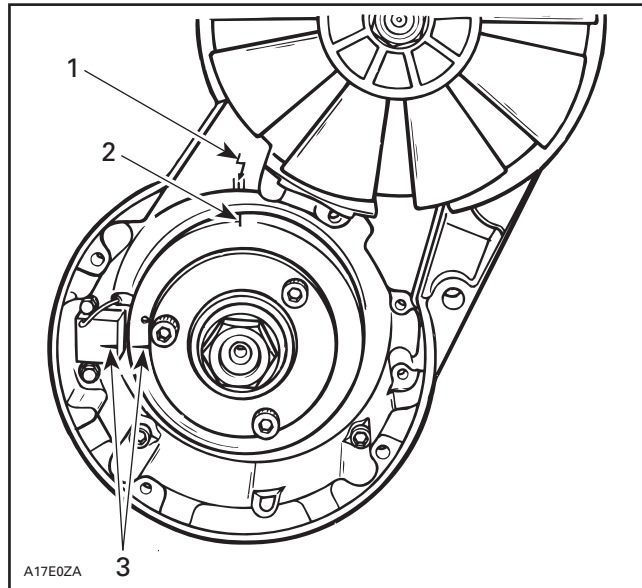

TYPICAL

1. Crankcase arrow
2. Scribe a mark here
3. Maintain verified timing marks aligned (static timing)

Checking Ignition Timing

Use a timing light and the digital/inductive type tachometer (P/N 529 014 500).

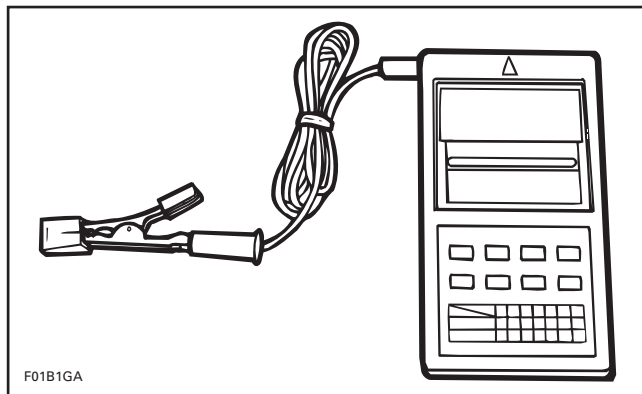

TACHOMETER

To check the ignition timing, refer to illustration and proceed as follows:

- Place ski tips against a wall, raise rear of vehicle on a stand, so that track does not contact the ground.

⚠ WARNING

Do not allow anyone in front of or behind the vehicle while engine is running. Keep clear of track and do not wear loose clothing which can get caught in moving parts.

- Connect the timing light pick-up to a spark plug cable.

NOTE: To avoid an incorrect reading due to parallax, view the magneto flywheel and the crankcase timing marks in a straight line.

- Connect tachometer wire to spark plug wire or aim tachometer toward spark plug wire without using any connection wire.
- Start the engine and raise the engine speed at least to 3500 RPM (\pm 500 RPM) while observing the timing marks, refer to illustration. The magneto flywheel mark scribed previously and the crankcase arrow should be perfectly aligned. If the marks do not align, a faulty trigger coil (check proper grounding of coil), a faulty flywheel, a faulty Woodruff key, a misaligned (twisted) crankshaft or a faulty CDI module could be the cause: substitute one part at a time and recheck timing marks (check connectors condition prior to substituting any part).

NOTE: Ignition timing may be verified when engine speed is anywhere within 3000 - 4000 RPM.



TYPICAL

- Install parts which were removed.

Liquid-Cooled Engines

Normally ignition timing adjustment should not be required. It has been set at factory and it should remain correctly adjusted since every part is fixed and not adjustable. The only time the ignition timing might have to be changed would be when removing and reinstalling the magneto housing, replacing the crankshaft, the magneto flywheel, the trigger coil or the MPEM or ECM. If the ignition timing is found incorrect, first check for proper crankshaft alignment. This might be the indication of a twisted crankshaft. Refer to LEAK TEST AND ENGINE DIMENSION MEASUREMENT.

The ignition timing can be checked with either the engine hot or cold. Also, the ignition timing is to be checked at 3500 RPM with a timing light except on **SDI engines**. On these engine the ignition timing must be checked at 4000 RPM.

NOTE: Except on the **SDI models**, between 3000 and 4000 RPM, the spark advance does not change. So when checking ignition timing at 3500 RPM, a change in engine speed within \pm 500 RPM will not affect the timing mark when checked with the timing light.

Scribing a Timing Mark

NOTE: Before performing ignition timing on **793 HO Power TEK engines**, disconnect the TPS.

- Clean the area around the MAG spark plug, and remove it.
- Install the TDC gauge in the spark plug hole, (magneto side) and adjust as follows:
 - Position the MAG piston at approximately TDC.

Section 07 ELECTRICAL SYSTEM

Subsection 01 (IGNITION SYSTEM)

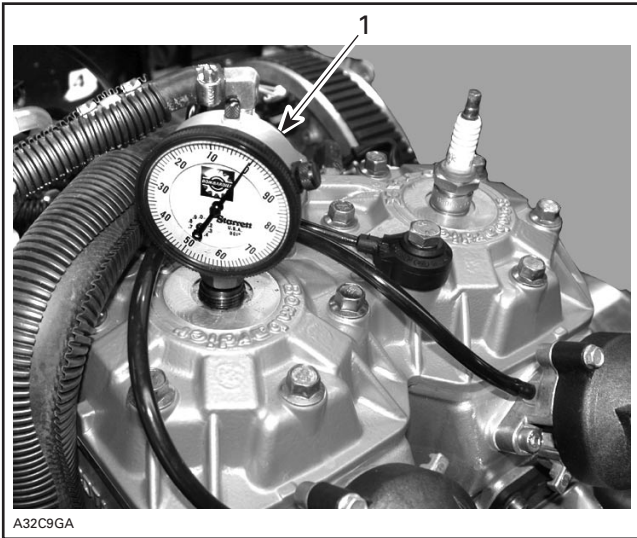

TYPICAL
1. TDC gauge on MAG side

- Assemble the gauge to the adaptor and tighten the roller lock nut. Do not tighten the adaptor lock nut.
- Screw the adaptor into the spark plug hole and tighten to prevent movement in the plug hole.
- Position the dial face toward the PTO. Move the gauge down until the needle just begins to move, then move down a further 5 or 6 mm (approximately 1/4 in). Tighten adaptor lock nut by hand.
- Locate the piston TDC position as follows:
 - Slowly rotate the drive pulley back and forth across TDC while observing the needle. Note that the needle stops moving only as the piston is changing direction.
 - Rotate the dial face so that «0» is in line with the needle when it stops moving.
 - Again, slowly rotate the drive pulley back and forth across TDC and adjust the dial face to «0», until the needle always stops exactly at «0» before changing direction.
 - «0» now indicates exact TDC.
- Rotate the drive pulley clockwise, one-quarter turn then carefully rotate it counterclockwise until the needle indicates the specified measurement, indicated in TECHNICAL DATA.
- Twist a wire as shown and use it as a pointer. Install the wire on upper starter bolt.

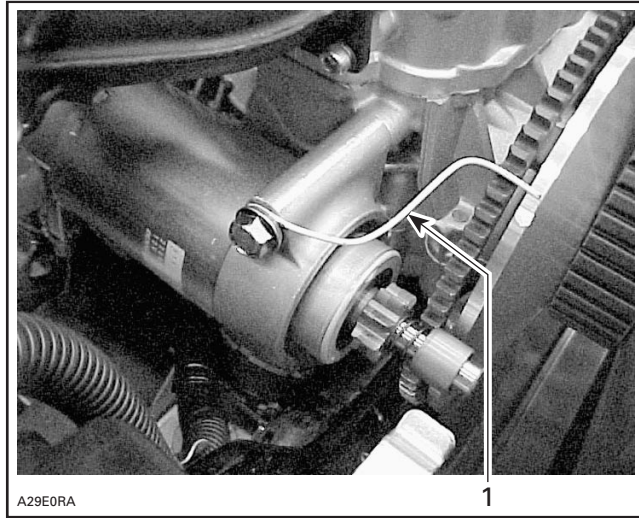

1. Pointer

- With the TDC gauge indicating specified timing, scribe a mark on drive pulley inner half in line with pointer end.

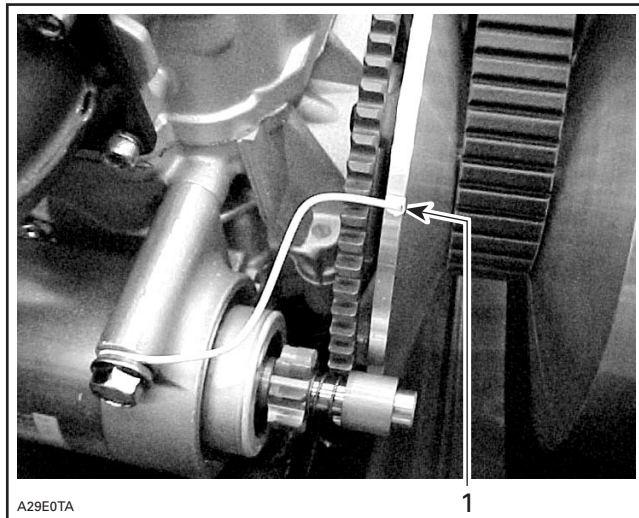

1. TIMING MARK IN LINE WITH POINTER END

Checking Ignition Timing

To check the ignition timing proceed as follows:

⚠ WARNING

Place ski tips against a wall, raise rear of vehicle on a stand, so that track does not contact the ground. Do not allow anyone in front of or behind the vehicle while engine is running. Keep clear of track and do not wear loose clothing which can get caught in moving parts.

Section 07 ELECTRICAL SYSTEM
Subsection 01 (IGNITION SYSTEM)

Connect the timing light pick-up to a spark plug cable.

Connect the digital/inductive type tachometer (P/N 529 014 500).

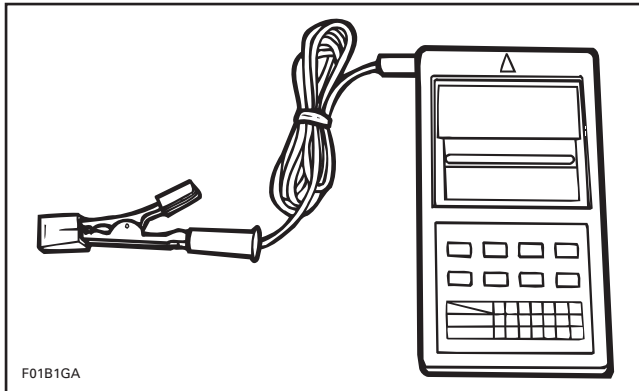

TACHOMETER

Start the engine and point timing light on timing mark. Bring engine to 3500 RPM for a brief instant.

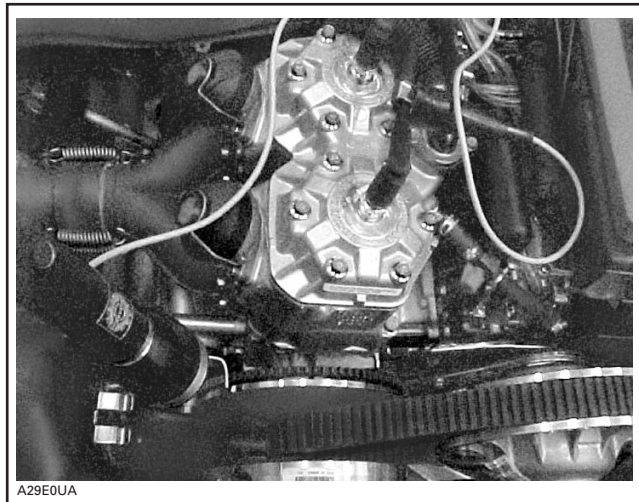

The timing mark must be aligned with pointer end. If such is not the case, note if timing is retarded or advanced.

ENGINE TYPE	TOLERANCE
593	$\pm 1^\circ$
593 HO, 593 HO SDI, 793 HO	$\pm 0.5^\circ$

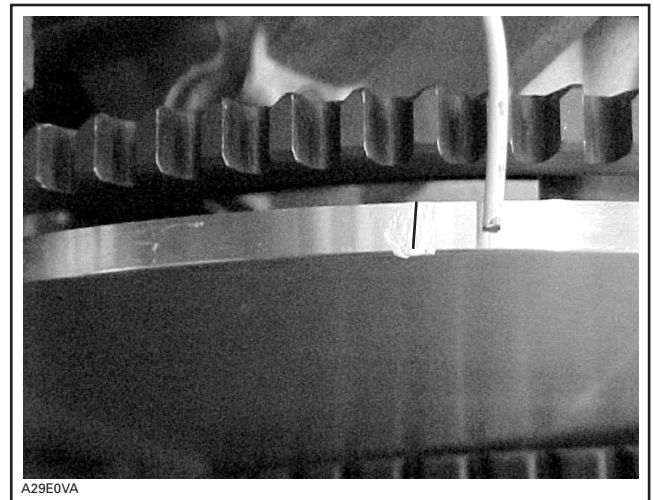

TIMING RETARDED BY ABOUT 1°

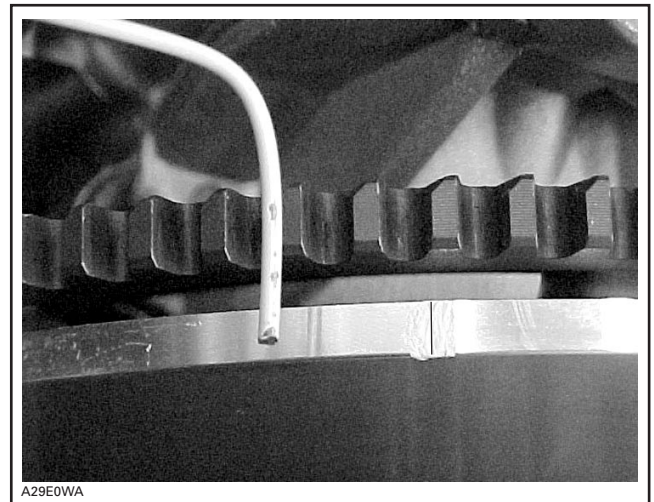

TIMING ADVANCED BY ABOUT 2°

Changing Timing

NOTE: To change the timing on **SDI and Power TEK engines**, the Vehicle Communication Kit (VCK) (P/N 529 035 981) is mandatory. The MPEM programmer cannot be used with these engines.

VCK (Vehicle Communication Kit)

The VCK must be used, with B.U.D.S. software to change the ignition timing. Look under the proper **Setting** section of the B.U.D.S. software to change the ignition timing.

Section 07 ELECTRICAL SYSTEM

Subsection 01 (IGNITION SYSTEM)

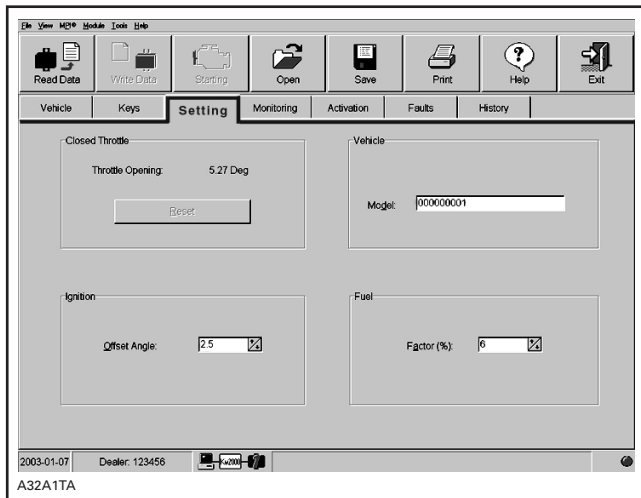

Detailed information about the B.U.D.S. software and its usage is available under its **Help** section.

MPEM Programmer

All Engines except SDI and Power TEK

Timing can also be changed using the MPEM programmer (P/N 529 035 878).

Connect the 9-volt adaptor (P/N 529 035 675) to the supply harness (P/N 529 035 869) and supply harness to diagnostic connector, located on right side of the vehicle.

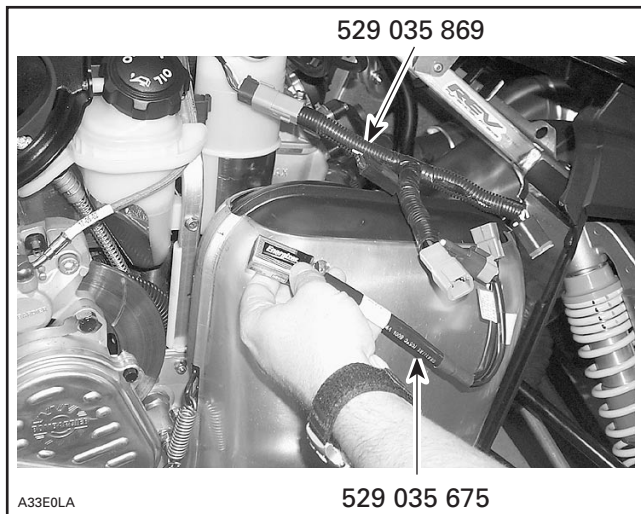

Connect MPEM programmer to DESS post.
Turn on programmer then enter password.
From main menu select no. 3. INFO VEHICLE.

1. CHECK KEYS
2. PROGRAM KEY
- > 3. VEHICLE INFO
- 4+ START VEH.

A30E1XA

Vehicle information is transferred from MPEM to programmer.

TRANSFER
PGMR ← MPEM

A30E1YA

NOTE: In fact the programmer takes a **copy** of all vehicle parameters scribed in MPEM. This copy will be modified within the programmer then transferred to the MPEM.

Select no. 4. ENGINE PARAMETER.

1. CUSTOMER NAME
2. DELIVERY DATE
3. VEH. SERIAL#
- > 4+ ENGINE PARAM.

A30E1ZA

Select no. 1 TIMING ADJUSTMENT.

- > 1. TIMING ADJUST
2. ENGINE SERIAL#
3. CALIBRATION

A30E2GA

Press ENTER.

Section 07 ELECTRICAL SYSTEM
Subsection 01 (IGNITION SYSTEM)

Now the display shows the engine timing correction factor that is programmed in the MPEM. In the following example timing correction factor is no. 4.

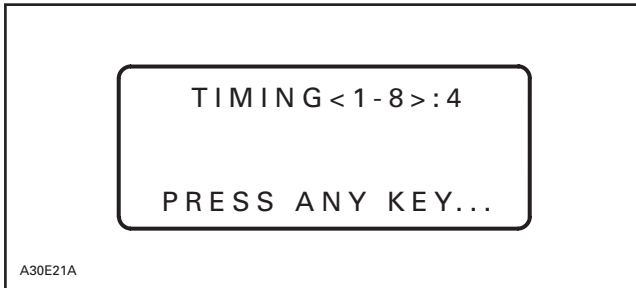

Press any key.

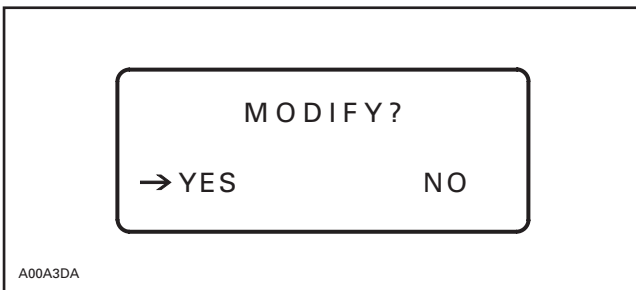

Select YES using the key ↔.

Press ENTER.

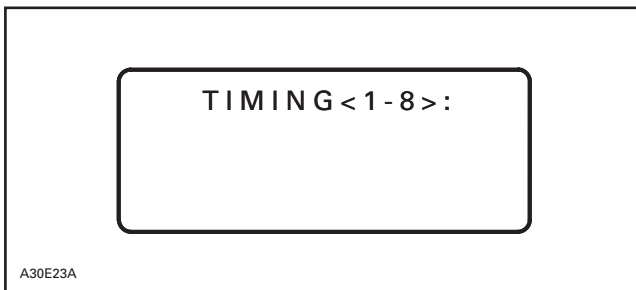

Select a timing correction factor corresponding to correction needed.

Example: Timing mark as verified with a timing light at 3500 RPM was too early by 2°. The correction factor programmed is no. 4.

Select correction factor no. 5. This will retard the timing by 2° because the difference between correction factor no. 4 and no. 5 is - 2° (passing from 1° to - 1°).

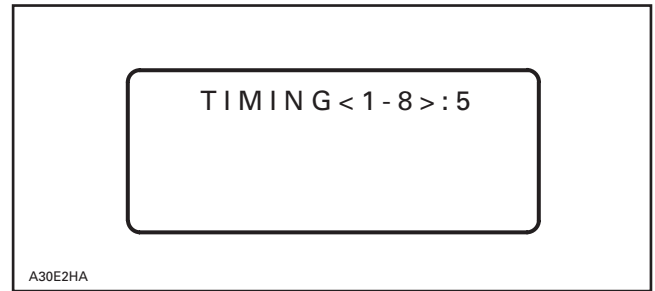

IGNITION CORRECTION FACTOR	
CORRECTION FACTOR PROGRAMMED IN MPEM	IGNITION TIMING CORRECTION
2	3°
3	2°
4	1°
1	0°
5	- 1°
6	- 2°
7	- 3°
8	- 4°

Press ENTER.

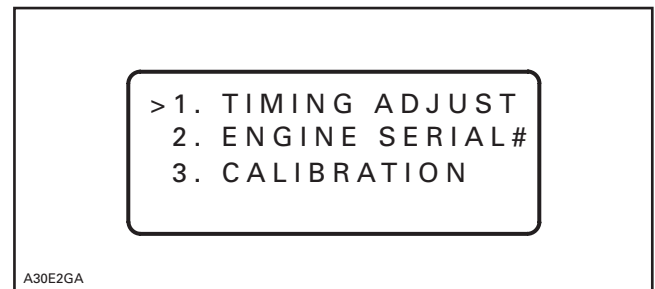

Press ENTER.

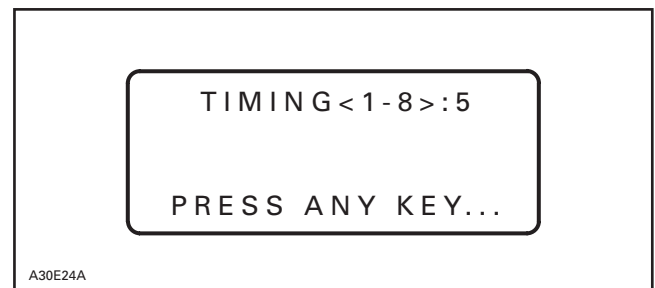

The display confirms that correction factor has been changed to no. 5.

Press any key.

Section 07 ELECTRICAL SYSTEM

Subsection 01 (IGNITION SYSTEM)

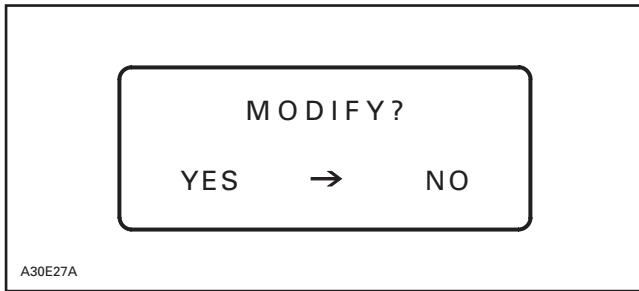

If the new correction factor selected above is the good one select NO and press ENTER. Otherwise select YES to choose an other correction factor.

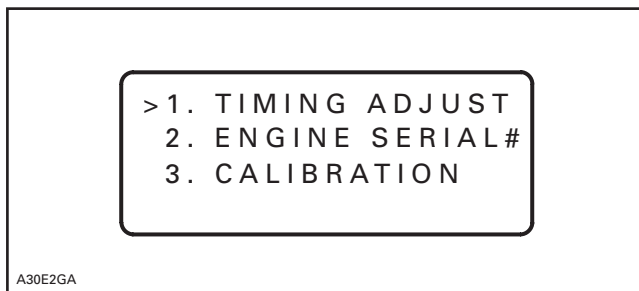

Press MENU.

Scroll to no. 7 SAVE AND QUIT.

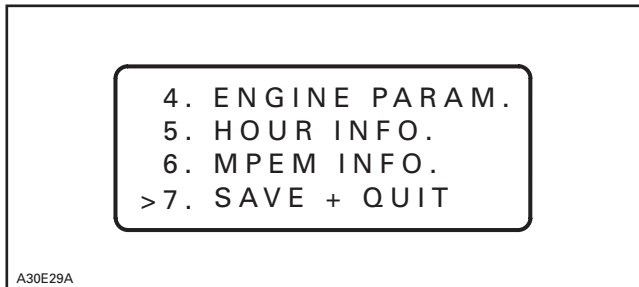

Press ENTER.

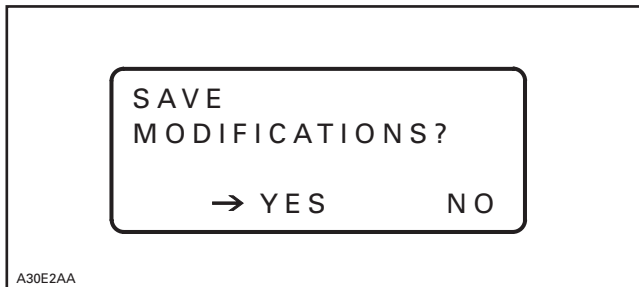

Press ENTER.

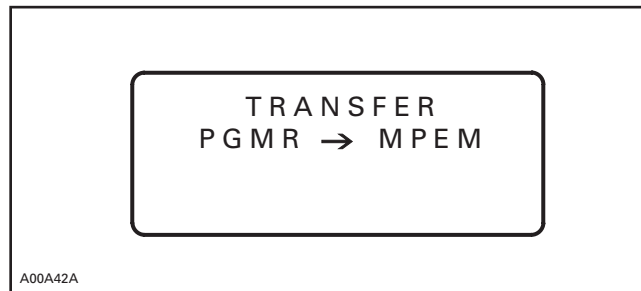

During a very short period of time the following message will appear.

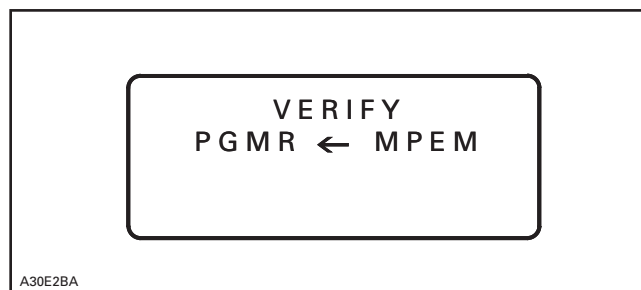

After the programmer has verified, following message will appear.

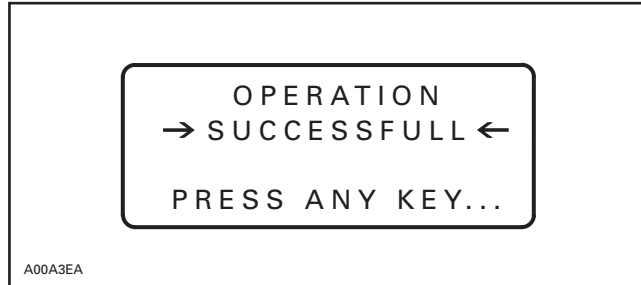

Press any key.

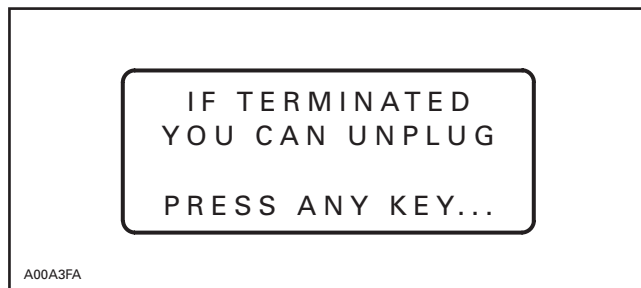

Press any key.

Section 07 ELECTRICAL SYSTEM
Subsection 01 (IGNITION SYSTEM)

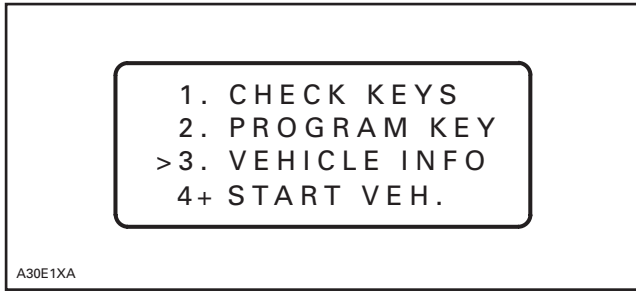

Unplug supply harness and 9-volt adaptor.
 Recheck ignition timing with timing light when completed.

SPARK PLUG

Removal

First unscrew the spark plug 1 turn.
 Clean the spark plug and cylinder head with pressurized air, then completely unscrew.

⚠ WARNING
 Whenever using compressed air, always wear protective eye wear.

Installation

Prior to installation make sure that contact surfaces of the cylinder head and spark plug are free of grime.

Using a feeler gauge, set electrode at the proper gap except if the spark plug is a BR9ECS. Refer to TECHNICAL DATA.

CAUTION: Do not adjust electrode gap of BR9ECS spark plug.

- 1) Apply antiseize lubricant (P/N 293 800 070) over the spark plug threads to prevent possible seizure.
- 2) Hand screw spark plug into cylinder head and tighten with a torque wrench and a proper socket.

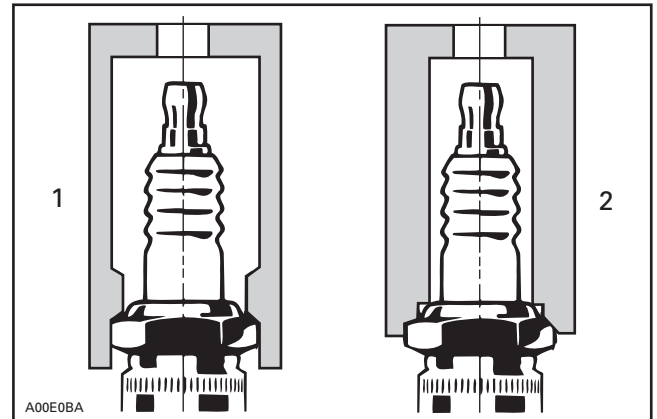

TYPICAL
 1. Proper socket
 2. Improper socket

Use the following table to torque the spark plugs.

MODEL	SPARK PLUGS	TORQUE N•m (lbf•ft)
All models	NGK	27 (20)

DESIGN SYMBOLS USED IN NGK SPARK PLUGS

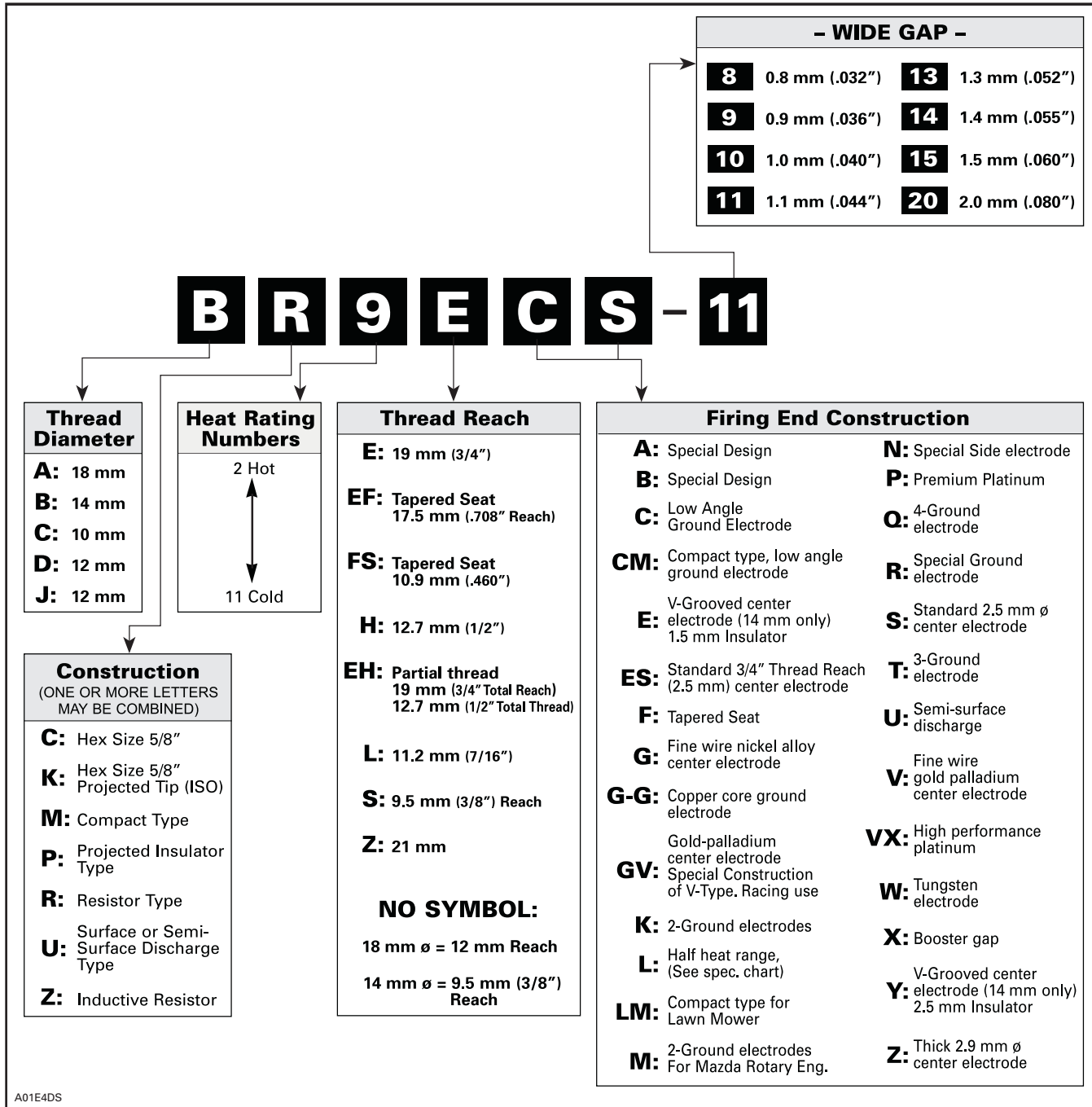

CHARGING SYSTEM

SERVICE TOOLS

Description	Part Number	Page
crimp pliers.....	529 035 730	297
multimeter FLUKE 111	529 035 868	293

SERVICE PRODUCTS

Description	Part Number	Page
silicone dielectric grease	293 550 004	296–297

GENERAL

Voltage measurements are always taken upon vehicle starting. Reading when the engine is running will be higher than indicated range. Part temperature must be approximately 20°C (68°F) (room temperature), otherwise reading could be distorted.

When testing the different magneto components, it is important to take into consideration that reading vary according to the force applied onto the manual starter. It is therefore important to employ enough force upon each trial.

The reading must be 3 times within or above the range indicated in the corresponding table. If the reading is too low, the part is considered to be defective and must be replaced.

Place the selector switch of the multimeter FLUKE 111 (P/N 529 035 868) to Ω in order to measure resistance. Readings must be within the indicated range. Otherwise, the part is considered to be defective and must be replaced.

CAUTION: When taking measurements, it is useless to try to start the vehicle since readings would then be distorted.

It is difficult to make a diagnostic in the case of intermittent ignition problems. Thus, problems occurring only when the engine operating temperature is normal must be checked in similar conditions.

In most cases when problems are caused by temperature or vibrations, these can only be solved by replacing parts. Most problems cannot be detected when the engine is stopped.

As a matter of fact, more than one component can be defective. As a result, if the problem remains although a part was replaced, start over the whole verification from the beginning in order to identify the other defective component.

CHARGING GENERATOR COIL (STATOR)

First measure the resistance. To do this, disconnect connector.

Connect multimeter probes to YELLOW wires, then place selector switch to Ω .

Compare reading with those appearing in the table further.

Now measure the voltage.

Connect the multimeter probes to appropriate wires, refer to table below.

Bring the selector switch of multimeter to V and the scale to 00.0 Vac.

Activate the manual starter and check values.

Repeat operation 3 times.

Compare reading with those appearing in the following table.

Section 07 ELECTRICAL SYSTEM

Subsection 02 (CHARGING SYSTEM)

FAN-COOLED ENGINES			
PART	Charging generator coil		
TEST	Power	Insulation	Ground continuity
TEST PROBES	YELLOW and YELLOW/BLACK	YELLOW and ENGINE	BLACK and ENGINE
RESISTANCE	00.0 to 00.6	O.L.	00.0 to 00.5
VOLTAGE	3.0 to 7.0	—	—
NOTE	—	Engine refers to the engine parts connected to the magneto housing.	

LIQUID-COOLED ENGINES		
PART	Stator	
TEST	Output	Coil insulation
TEST PROBES	YELLOW, YELLOW and GREEN	YELLOW and ENGINE
RESISTANCE	00.0 to 00.5 3 times	O.L.
VOLTAGE	3.5 to 5.5 3 times	—
NOTE	Do the test between A and B, A and C and B and C using manual starter	Engine refers to the engine parts connected to the magneto housing.

VOLTAGE REGULATOR/RECTIFIER

Test

To test the voltage regulator/rectifier use the following table.

FAN-COOLED ENGINES WITH MANUAL STARTER		
TEST	Charging voltage	Current to battery
TEST PROBES	RED/GREEN and negative battery terminal	RED and RED/WHITE
RESISTANCE	—	—
VOLTAGE	Battery voltage	2 to 4 A
NOTE	The 5 A fuse is located on the electrical supply harness	Engine @ 5000 RPM with fully charged battery. With 30 A fuse removed and ammeter in series.

FAN-COOLED ENGINES WITH ELECTRIC STARTER		
TEST	Charging voltage	Current to battery
TEST PROBES	RED/GREEN and negative battery terminal	RED and RED/WHITE
RESISTANCE	—	—
VOLTAGE	Battery voltage	2 to 4 A
NOTE	The 5 A fuse is located on the electrical supply harness	Engine @ 5000 RPM with fully charged battery. With 30 A fuse removed and ammeter in series.

LIQUID-COOLED ENGINES WITH MANUAL STARTER		
TEST	Charging voltage	Current to battery
TEST PROBES		RED and RED/WHITE
RESISTANCE	—	—
VOLTAGE	Battery voltage	2 to 4 A
NOTE	—	Engine @ 5000 RPM with fully charged battery. With 30 A fuse removed and ammeter in series.

LIQUID-COOLED ENGINES WITH ELECTRIC STARTER		
TEST	Charging voltage	Current to battery
TEST PROBES	RED/GREEN and negative battery terminal	RED and RED/WHITE
RESISTANCE	—	—
VOLTAGE	Battery voltage	2 to 4 A
NOTE	—	Engine @ 5000 RPM with fully charged battery. With 30 A fuse removed and ammeter in series.

If the voltage regulator/rectifier is within the specification, the wiring harness between the voltage regulator/rectifier and battery is defective. If the voltage regulator/rectifier is out of specification and the stator tests good, the voltage regulator/rectifier is defective.

Section 07 ELECTRICAL SYSTEM

Subsection 02 (CHARGING SYSTEM)

Removal

MODEL	LOCATION
Fan-cooled engines	RH side of vehicle, under chaincase
Liquid-cooled engine	LH side of vehicle, behind driven pulley

All Models

Disconnect battery (if so equipped).
 Unplug the voltage regulator/rectifier connector.
 Remove screws that attach the voltage regulator/rectifier to the frame.

Installation

The installation is the reverse of the removal procedure.
 Torque voltage regulator/rectifier screws to 5 N•m (44 lbf•in).

BATTERY

NOTE: For manual start SDI models with a small battery/capacitor arrangement, refer to ENGINE MANAGEMENT SECTION.

General

Sealed valve regulated lead acid (VRLA) battery are used. They are non-spillable and maintenance reduced — no electrolyte level to be checked and readjusted. No ventilation tube is attached to the battery.

SUPPLIER P/N	BRP P/N
YTX20L-BS	515 175 642

Removal

⚠ WARNING

Battery BLACK (–) cable must always be disconnected first and connected last.

⚠ WARNING

Never charge or boost battery while installed on vehicle.

Open right side panel of vehicle.

Disconnect BLACK (–) cable end from the terminal.

Slide off rubber boot from RED (+) cable and disconnect it.

Unscrew the bracket retaining nut and lift bracket to remove it.

Put bracket aside.

Remove battery.

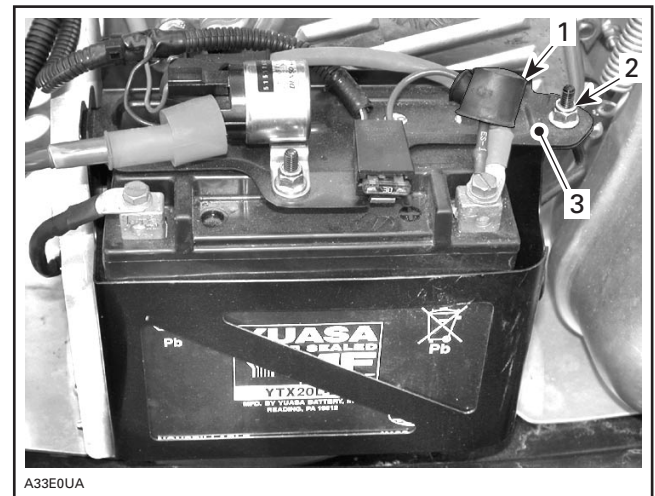

1. Rubber boot of RED (+) cable terminal
2. Bracket retaining nut
3. Battery bracket

CAUTION: Should any electrolyte spillage occur, immediately wash off with a solution of baking soda and water to prevent damage to vehicle components.

Cleaning

Clean the battery, battery casing, cables and battery posts using a solution of baking soda and water.

Remove corrosion from battery cable terminals and battery posts using a firm wire brush. Battery top should be cleaned by soft brush and any grease-cutting soap or baking soda solution.

Inspection

Visually inspect battery casing for cracks, leaks or other possible damage. Discoloration, warping or raised top, indicates that battery has overheated or been overcharged. If casing is damaged, replace battery and thoroughly clean battery tray and close area with water and baking soda.

Section 07 ELECTRICAL SYSTEM

Subsection 02 (CHARGING SYSTEM)

WARNING

Should the battery casing be damaged, wear a suitable pair of non-absorbent gloves when removing the battery by hand.

Inspect battery posts for security of mounting.

Battery Charge Testing

Voltmeter Test

NOTE: To determine the battery state of charge, these sealed batteries have to be tested with a voltmeter. They also need to be tested when their voltage is stabilized. Disconnect battery to have open connectors and wait 1-2 hours prior to reading the voltage. The same condition is required after a battery has been charged.

Batteries with a voltage above 12.8 V do not need to be charged.

Batteries with a voltage of 12.8 V and below need to be charged. Refer to BATTERY CHARGING below.

BATTERY STORAGE

CAUTION: A discharged battery will freeze and it may damage its casing. A damaged casing will allow electrolyte spillage that may damage surrounding parts.

Disconnect and remove battery from the vehicle.

The battery must always be stored in fully charged condition.

Clean battery terminals and cable connections using a wire brush. Apply a light coat of silicone dielectric grease (P/N 293 550 004) or petroleum jelly on terminals.

Clean battery casing using a solution of baking soda and water. Rinse battery with clear water and dry well using a clean cloth.

Charge the battery every month if stored at temperature **below** 15°C (60°F).

Charge the battery every two week if stored at temperature **above** 15°C (60°F).

Activation of New Battery

Refer to the instructions provided with the battery.

Battery Charging

WARNING

Always wear safety glasses and charge in a ventilated area. Never charge or boost battery while installed on vehicle. Do not open the sealed caps during charging. Do not place battery near open flame.

CAUTION: If battery becomes hot, stop charging and allow it to cool before continuing.

NOTE: Sealed VRLA batteries have an internal safety valve. If battery pressure increases due to overcharging, the valve opens to release excess pressure, preventing battery damage.

Perform BATTERY CHARGE TESTING above then proceed as described here.

An automatic charger is the fastest and most convenient way for error-proof charging.

When using a constant current charger, charge battery according to the chart below.

Battery Voltage Below 12.8 V and Above 11.5 V

STANDARD CHARGING (RECOMMENDED)		
BATTERY TYPE	TIME	CHARGE
YTX20L-BS	4-9 HOURS	2 A

QUICK CHARGING		
BATTERY TYPE	TIME	CHARGE
YTX20L-BS	50 MINUTES	10 A

Battery Voltage Below 11.5 V

Batteries with voltage below 11.5 V requires special procedures to recharge. In charging an over discharged battery, its internal resistance may be too high to charge at a normal charging voltage. Therefore, it may be necessary to raise the voltage of the battery initially to 25 V as a maximum, and charge for approximately 5 minutes.

Section 07 ELECTRICAL SYSTEM

Subsection 02 (CHARGING SYSTEM)

If the charger ammeter shows no change in current after 5 minutes, you need a new battery. Current flowing into the battery at high voltage can become excessive. Monitor amperage and adjust voltage as necessary to keep current at the battery's standard amp rating. Charge for approximately 20 hours.

Installation

Reinstall battery and secure bracket properly. Connect RED (+) cable it to positive battery terminal. Connect RED wire (coming from 30 A fuse). Connect BLACK (-) cable LAST.

⚠ WARNING

Battery BLACK (-) cable must always be disconnected first and connected last.

⚠ WARNING

Never charge or boost battery while installed on vehicle.

Cover the RED (+) terminal with rubber boot. Apply silicone dielectric grease (P/N 293 550 004) on battery posts and connectors.

CABLE TERMINAL INSTALLATION

Carefully strip the wire approximately to 10 mm (1/2 in) in length, using a wire stripping tool or sharp blade/knife.

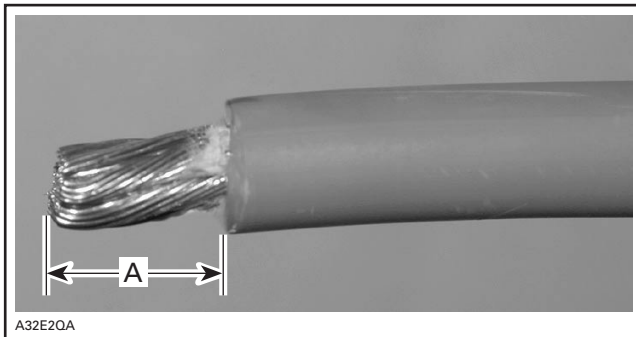

A. 10 mm (1/2 in)

NOTE: Make sure not to cut wire strands while stripping the wire.

Install the appropriate terminal on the wire according to the requirement. Refer to appropriate parts catalog.

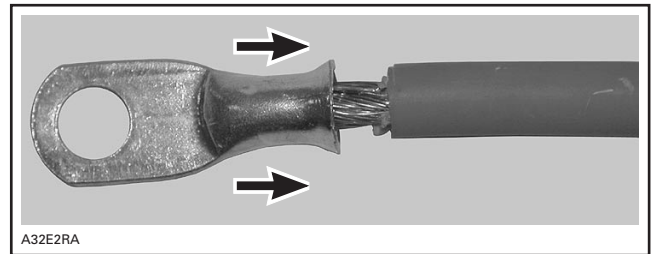

INSTALLATION OF TERMINAL

Follow the instructions provided with the crimp pliers (P/N 529 035 730) to select the proper position of the tool.



NOTE: Different wires require different crimp pliers settings, so make sure to follow the instruction supplied with the tool.

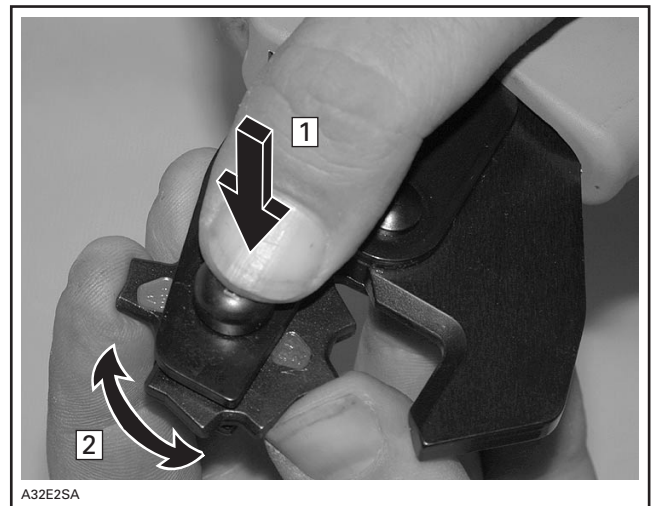

POSITIONING THE CRIMP PLIERS

1. Press
2. Rotate

After positioning the crimp pliers, crimp the terminal already installed on wire.

Section 07 ELECTRICAL SYSTEM

Subsection 02 (CHARGING SYSTEM)

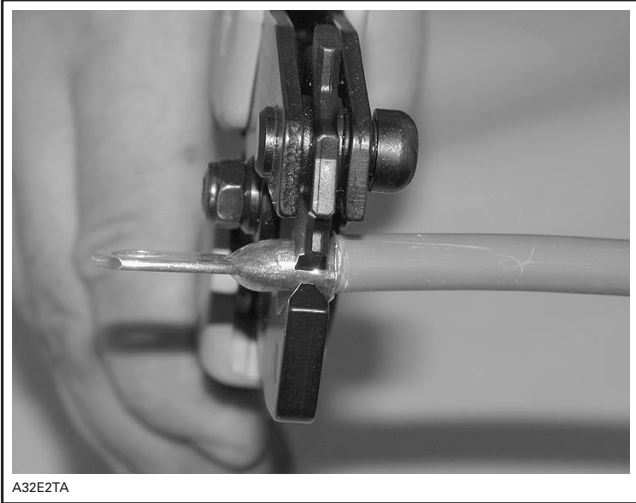

CRIMPING OF WIRE

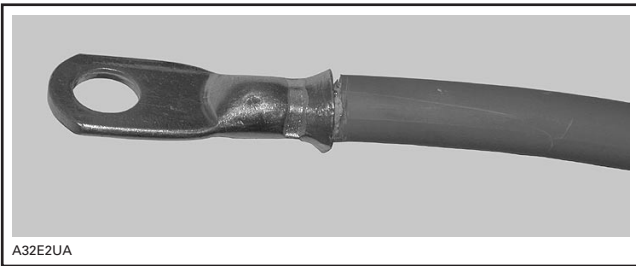

PROPERLY CRIMPED WIRE

To verify, if the wire is properly crimped, apply some pulling force on wire and the terminal at the same time from both directions.

CAUTION: Never solder the wire to the terminal. Soldering can change the property of the wire and it can become brittle and break.

Install the protective heat shrink rubber tube on the terminal. Heat the heat shrink rubber tube using the heat gun so that it grasps the wire and the terminal.

CAUTION: Make sure that the protective heat shrink rubber tube has been properly installed and no part of wire is exposed.

STARTING SYSTEM

SERVICE TOOLS

<u>Description</u>	<u>Part Number</u>	<u>Page</u>
multimeter FLUKE 111	529 035 868	301–302

SERVICE PRODUCTS

<u>Description</u>	<u>Part Number</u>	<u>Page</u>
synthetic grease	413 711 500	303, 305

Section 07 ELECTRICAL SYSTEM

Subsection 03 (STARTING SYSTEM)

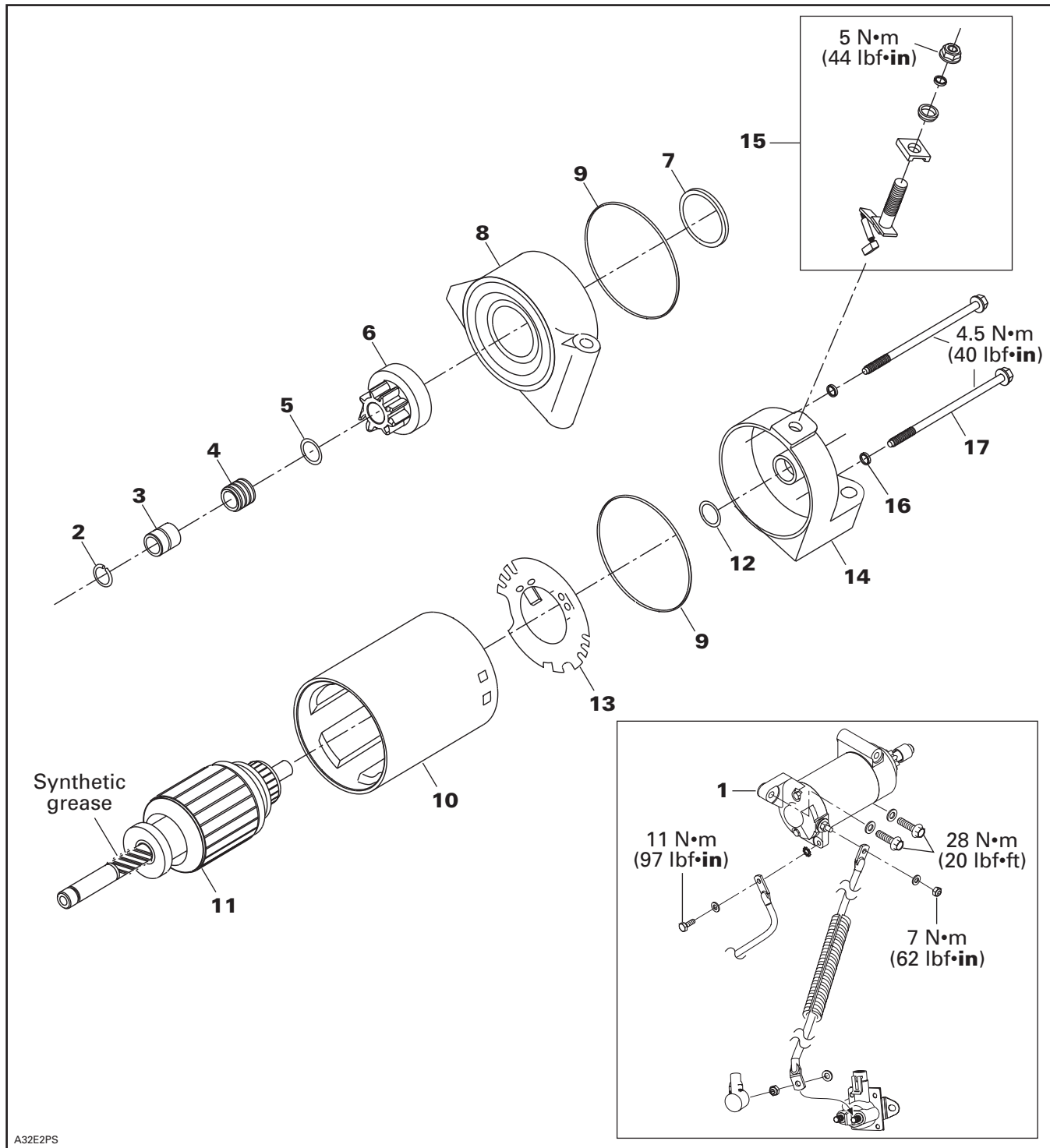

A32E2PS

ELECTRIC STARTER

TROUBLESHOOTING

When the ignition switch is turned on or the start button is pressed, a signal is sent to the starting solenoid. The battery then supplies current to the starter through the starting solenoid to turn the engine.

In case of problems, first ensure the problem is not related to engine mechanical components. If not, test the starting system.

Causes of problems are not necessarily related to starter but may be due to a burnt fuse, faulty battery, start button or ignition switch, engine cut-out switch, starting solenoid, electrical cables and connections or the electronic module.

Check these components before removing starter.

Fuses

Make sure the charging fuse (30 A) on battery and the MPEM fuse (5 A) on electrical harness are in good condition. If the fuses test good, continue with the next tests.

Battery

Refer to CHARGING SYSTEM to check battery condition. If the test is good, continue with the next tests.

Start/RER Button

Liquid-Cooled Engines Models

Check if the start/RER button works perfectly.

START/RER BUTTON ON VEHICLES WITH ELECTRIC STARTER		
<i>All engines except SDI</i>		
TEST	Continuity from start/RER button to MPEM	Voltage from voltage regulator/rectifier
WIRE COLOR	RED/GREY and BEIGE	RED/GREY and BEIGE
RESISTANCE	1.0 Ω	—
VOLTAGE	—	Above battery voltage and below 15 volts
NOTE	—	—
<i>SDI engines</i>		
TEST	Continuity from start/RER button to MPEM	Voltage from voltage regulator/rectifier
WIRE COLOR	BLACK and BLACK/BLUE	BLACK and BLACK/BLUE
RESISTANCE	1.0 Ω	—
VOLTAGE	—	Above battery voltage and below 15 volts
NOTE	—	—

If the switch functions correctly, continue with the next tests.

Ignition Switch

Fan-Cooled Engines Models

Disconnect switch housing. Using the multimeter FLUKE 111 (P/N 529 035 868), check between MAG and GRD terminals if the circuit is open (O.L.) in operating position and if it is closed (0 Ω) in off position.

Engine Cut-Out Switch

Check the condition of engine cut-out switch.

Section 07 ELECTRICAL SYSTEM

Subsection 03 (STARTING SYSTEM)

ENGINE CUT-OUT SWITCH ON VEHICLE WITH ELECTRIC STARTER		
TEST	Running insulation	Continuity in STOP position
WIRE COLOR	BLACK/YELLOW and BLACK	BLACK/YELLOW and BLACK
RESISTANCE	O.L.	00.0 to 00.5
VOLTAGE	—	—
NOTE	Engine cut-out switch must be in run position.	Engine cut-out switch must be in stop position.

Starting Solenoid

Ensure the solenoid receives electric current as follows. Using the multimeter FLUKE 111 (P/N 529 035 868), measure the voltage between the wires, indicate in the following table, when starting the vehicle. The tether cord must be installed.

ENGINE TYPES	COLOR OF WIRES
ALL SDI ENGINES	RED/GREY and ORANGE/BLACK
ALL POWER TEK ENGINES	RED/GREEN and ORANGE/BLACK
ALL OTHER ENGINES	RED/GREEN and BLACK

If the solenoid does not properly receive current, the electronic module can be suspected.

If the solenoid receives current, test it as follows.

- Disconnect battery and starter cables from solenoid.
- Inspect connections and clean as necessary.
- Solenoid condition can be checked with an ohmmeter. Install probes on large connectors of solenoid.
- Measure the resistance when current is applied to small connectors; if it is more than a few ohms, replace solenoid.

If solenoid tests good, check the electric starter. If electric starter tests good, the electronic module can be suspected.

Electrical Cables and Connections

Check all connections, harnesses and wires.

Tighten any loose connections.

Replace any chafed wires.

If wires, harnesses and connections are good, check the electric starter.

Electric Starter

Remove the tuned pipe and disconnect spark plug cables.

Using booster cable, carefully supply current from the battery directly to the starter. Connect the BLACK cable first. Connect the remaining booster cable from the battery then to the starter.

If the starter turns, ensure wiring harness and connectors between battery and starter are in good condition. If they test good, the electronic module can be suspected.

If the starter does not turn, check for mechanical problem in the starter.

Electronic Module

Check the MPEM condition, refer to IGNITION SYSTEM. For **SDI and Power TEK engines**, refer to ENGINE MANAGEMENT.

STARTER REMOVAL

- Disconnect BLACK (-) cable from battery.
- Disconnect RED (+) cable from battery.

WARNING

Always disconnect BLACK (-) cable first and connect last.

- Remove tuned pipe.
- Disconnect RED cable from starter.
- Disconnect ground cable from starter.
- Remove stabilizer bar clamp to access the lower starter retaining bolt.

Section 07 ELECTRICAL SYSTEM

Subsection 03 (STARTING SYSTEM)

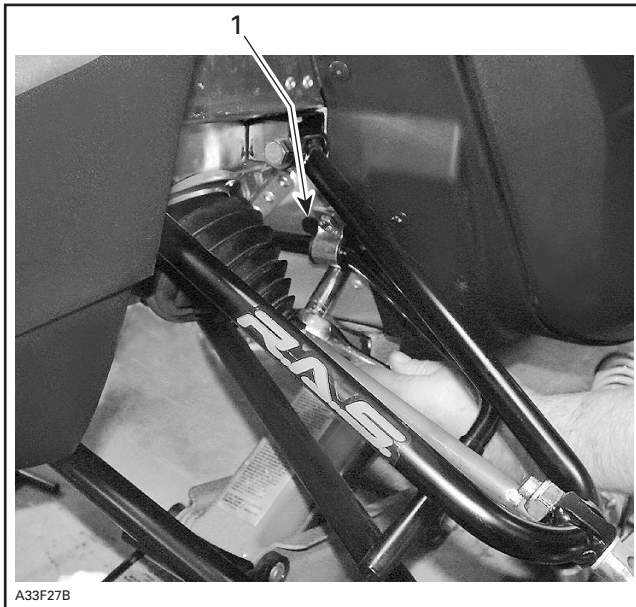

1. Clamp

- Unbolt and remove starter from engine.

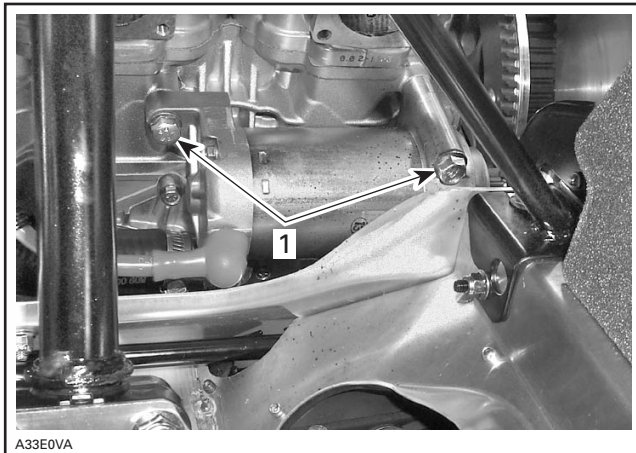

1. Bolts to be removed

STARTER DISASSEMBLY

Before disassembling, trace index marks on starter housing **no. 10** and starter housing assembly **no. 8** to ease further assembly.

Remove starter through bolts **no. 17**. Separate end frame housing **no. 14** from starter housing **no. 10**. Withdraw starter housing from armature **no. 11**.

Brush holder **no. 13** can be removed from end frame housing **no. 14** by disconnecting the end frame attached brush from brush holder **no. 13**.

Check the radial play between the armature shaft and end frame bearing. Replace the end frame bearing or replace starter. If parts are in good condition then coat with synthetic grease (P/N 413 711 500) before reinstalling them.

Push back the collar **no. 3** using a screwdriver.

Remove snap ring **no. 2**. Remove collar **no. 3** and spring **no. 4**.

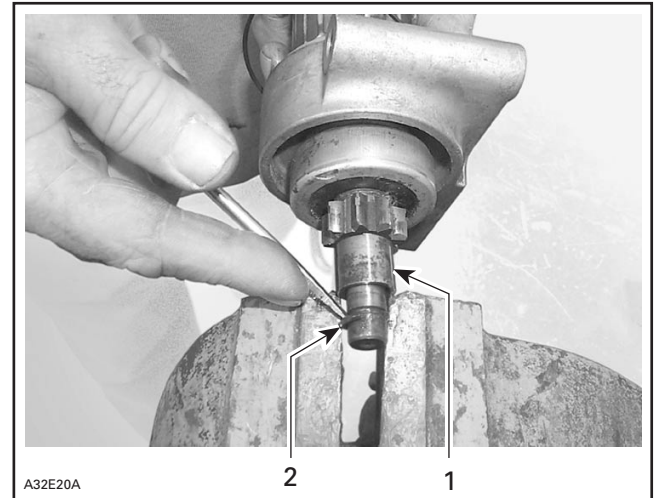

1. Collar
2. Snap ring

Turn starter clutch **no. 6** clockwise to remove it from armature assembly **no. 11**.

Pull housing from armature.

STARTER CLEANING

CAUTION: Yoke assembly and drive unit assembly must not be immersed in cleaning solvent.

Clean brushes and holders with a clean cloth soaked in solvent. Brushes must be dried thoroughly with a clean cloth.

Blow brush holders clean using compressed air.

WARNING

Always wear safety glasses when using compressed air.

Remove dirt, oil or grease from commutator using a clean cloth soaked in suitable solvent. Dry well using a clean and dry cloth.

Clean engine ring gear teeth and drive unit (clutch).

Section 07 ELECTRICAL SYSTEM

Subsection 03 (STARTING SYSTEM)

NOTE: Bushings or bearings must not be cleaned with grease dissolving agents.

Immerse all metal components in cleaning solution. Dry using a clean and dry cloth.

STARTER INSPECTION

Armature

NOTE: An ohmmeter may be used for the following testing procedures, except for the one concerning the shorted windings in the armature.

Check the commutator for roughness, burnt or scored surface. If necessary, turn the commutator on a lathe, enough to remove grime only.

Check the commutator for mica depth. If the depth is less than 0.20 mm (.008 in), undercut the mica. Be sure that no burrs are left and no copper dust remains between the segments after the undercutting operation is completed.

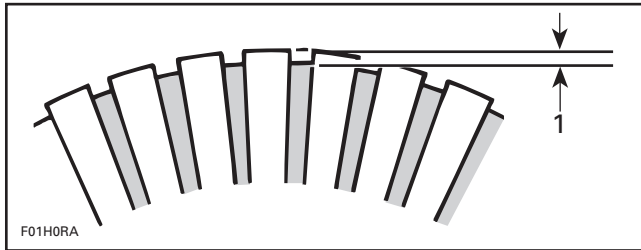

1. Commutator undercut 0.20 mm (.008 in)

Check the commutator out-of-round condition with V Blocks and an indicator. If the commutator out-of-round is more than 0.40 mm (.016 in), the commutator should be turned on a lathe.

Check commutator outer diameter. If less than specified value, replace.

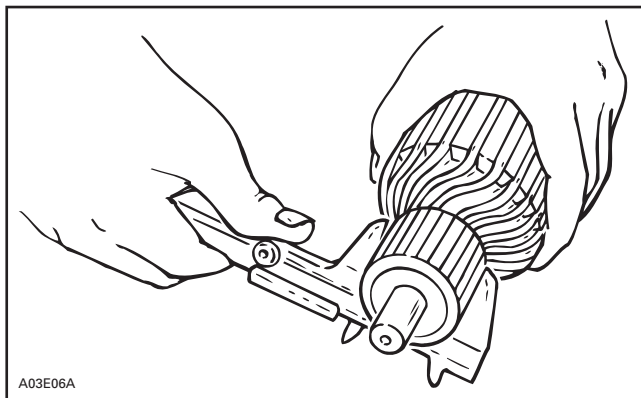

MODEL	WEAR LIMIT
All models	27 mm (1.063 in)

Test for Ground Circuit in the Armature

Use growler test probes. Check between armature core and the commutator bars. If growler lamp turns on, bars are grounded. If so, replace armature.

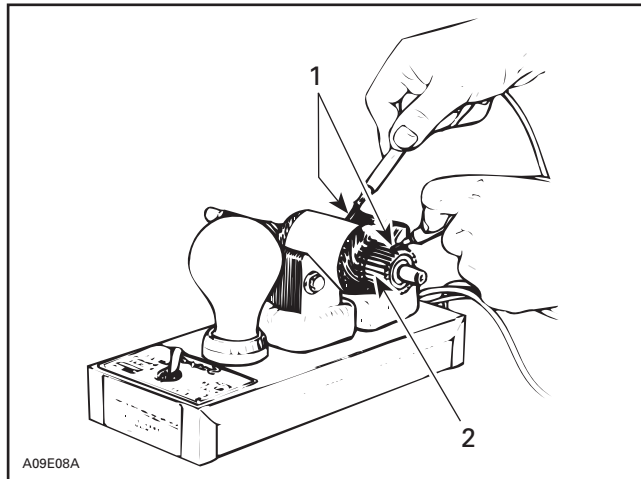

1. Test probes
2. Commutator bars

Test Armature for Shorted Winding

When the armature is rotated in the growler with a steel strip (hacksaw blade) held above it, the strip will vibrate over that area of the armature which has short circuit. Replace armature if so.

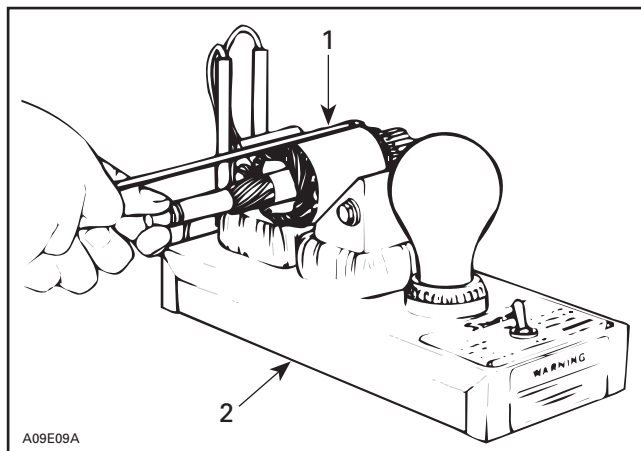

1. Steel strip (hack-saw blade)
2. Growler

Test the Armature for Open Circuit

Use growler test probes. Place one test probe on a commutator bar and the other test probe on the neighboring bar. Repeat this operation for all bars, moving one test probe at a time. If the growler lamp does not turn on, the armature circuit between these 2 bars is opened. The armature should be replaced or repaired; open circuits most often occur at the commutator riser where coils are soldered. (Burnt commutator bars are usually an indication of an open-circuit armature coil).

Brush Holder

Check the brush holder for insulation using growler test probes. Place one test probe on the insulated brush holder and the other test probe on the brush holder plate. If the growler lamp turns on, the brush holder has to be repaired or replaced.

Brush Length

Measure brush length. If less than the specified value, replace them.

MODEL	LENGTH	
	NEW	WEAR LIMIT
All	10 mm (.400 in)	6 mm (.236 in)

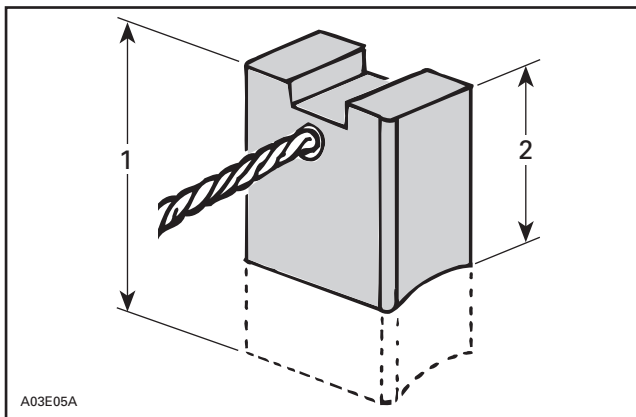

TYPICAL
 1. New
 2. Wear limit

End Housing

Check the mica insulation of the positive brush and also the roller bearing condition. Replace, if necessary.

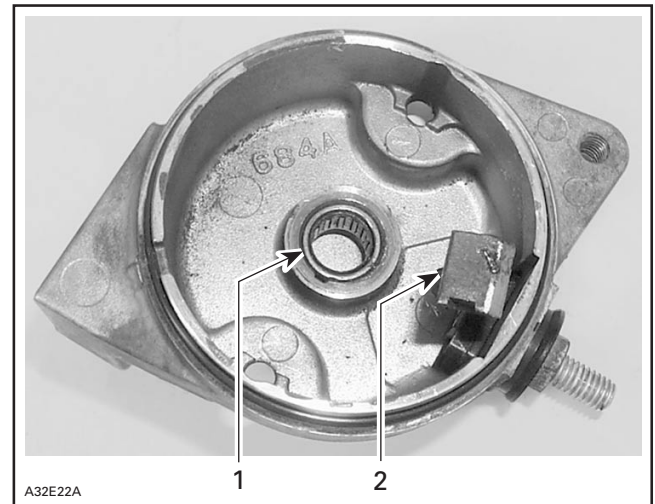

1. Roller bearing
 2. Positive brush

Overrunning Clutch

The pinion of the overrunning clutch should turn smoothly in a clockwise direction, and should not slip in a counterclockwise direction. If defective, replace.

Check the pinion teeth for wear and damage. If defective, replace.

Relay

Inspect connections and clean as necessary. Relay condition can be checked with an ohmmeter. Install test probes on large connectors of relay when it is activated ((+) on RED/GREEN wire and (-) on relay body for the fan cooled models and (-) on the BLACK wire for liquid cooled models).

IMPORTANT: No current must be present on large cables when using ohmmeter, otherwise meter could be damaged.

STARTER ASSEMBLY

Reverse the order of disassembly to reassemble starter. However, attention should be paid to the following operations.

Prior to assembling, coat sliding surfaces on armature shaft splines, overrunning clutch and bushing with synthetic grease (P/N 413 711 500).

After placing collar **no. 3** on armature shaft **no. 11**, fit new snap ring **no. 2** on armature shaft, then make sure that it is properly secured.

Slide collar **no. 3** over snap ring **no. 2** and secure in place by punching it at two or three places.

Section 07 ELECTRICAL SYSTEM

Subsection 03 (STARTING SYSTEM)

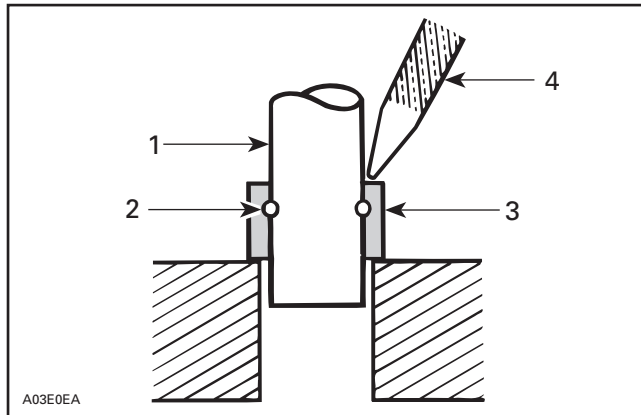

1. Armature shaft
2. Snap ring
3. Collar
4. Punch

Starter Housing Assembly and Starter Housing

Align previously traced indexing marks.

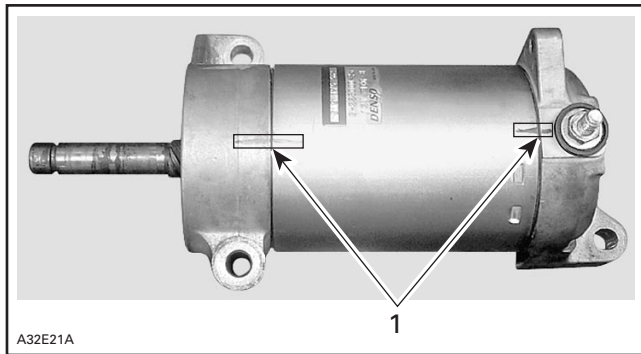

TYPICAL

1. Aligned indexing marks

Open brushes and slide over commutator.

Align end frame locating notch with yoke locating protrusion and properly sit brush holder no. 13 into housing no. 14.

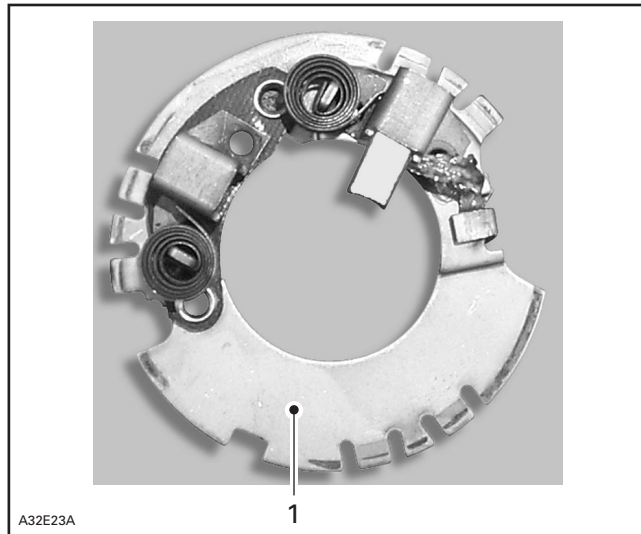

1. Brush holder

To ease end frame installation, retain brush holder with a small screwdriver while installing armature assembly.

CAUTION: Make sure to place two end housings on a flat surface before tightening the through bolts.

CAUTION: Make sure end frame fits perfectly on yoke.

STARTER INSTALLATION

- Use new teflon washers on the 3 bolts retaining starter to engine.
- Torque the bolts to 28 N•m (20 lbf•ft).
- Make sure that starter and engine mating surfaces are free of grime. Serious trouble may arise if starter is not properly aligned.
- Connect the RED battery cable and the RED wire to the large terminal of the starter.

⚠ WARNING

Always disconnect ground cable first and connect last.

- Torque large terminal nut to 7 N•m (62 lbf•in).
- Connect ground cable to the starter with star washer in between.
- Torque ground cable connecting bolt to 11 N•m (97 lbf•in).

ACCESSORIES

SERVICE TOOLS

Description	Part Number	Page
multimeter FLUKE 111	529 035 868	308, 312, 314–315
supply cable.....	529 035 997	307, 313
supply harness.....	529 035 869	307, 313
VCK (Vehicle Communication Kit).....	529 035 981	308

GENERAL

⚠ WARNING

It is recommended to always disconnect the battery when replacing any electric or electronic parts. Always disconnect battery exactly in the specified order, BLACK (-) cable first. Do not place tools on battery.

During assembly/installation, use the torque values and service products as in the exploded views.

Clean threads before applying a threadlocker. Refer to SELF-LOCKING FASTENERS and LOCTITE APPLICATION at the beginning of this manual for complete procedure.

⚠ WARNING

Torque wrench tightening specifications must be strictly be adhered to. Locking devices (e.g.: locking tabs, elastic stop nuts, self-locking fasteners, cotter pins, etc.) must be installed or replaced with new ones where specified. If the efficiency of a locking device is impaired, it must be renewed.

Lighting and Accessories System Testing

Connect the supply cable (P/N 529 035 997) to the supply harness (P/N 529 035 869). Respect polarity by connecting 12V to RED wire and ground to BLACK wire.

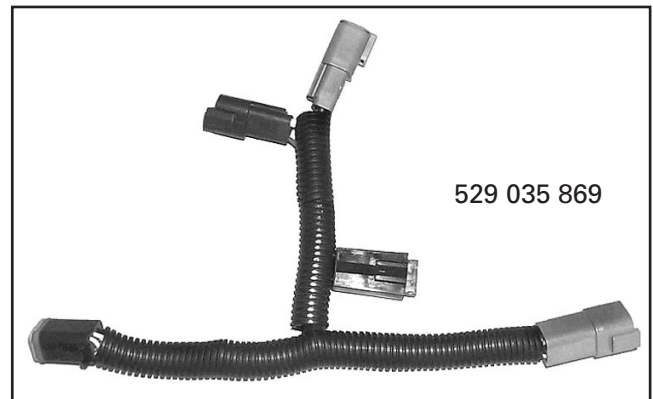

Connect the supply harness (P/N 529 035 869) to diagnostic connector, located on right side of the vehicle. Now the headlight and accessories systems are supplied with 12 volts. Refer to appropriate wiring diagram in WIRING DIAGRAM section to troubleshoot lighting system.

CAUTION: Always use the proper supply harness and cables. Ensure to respect polarity when connecting cable clips to battery. Match RED cables together.

Once lighting system testing is done, disconnect supply cable from vehicle and then 12-Volt supply from the supply cable.

Section 07 ELECTRICAL SYSTEM

Subsection 04 (ACCESSORIES)

480 W Models (SDI engines)

Connect the VCK (Vehicle Communication Kit) (P/N 529 035 981). In BUDS, click on the relay 2 (R2) button to supply lighting system with 12 volts.



To supply 12 volts to the accessories, click on the relay 3 (R3) button.

Use the wiring diagram in WIRING DIAGRAM section to troubleshoot lighting and accessories systems.

12-VOLT POWER OUTLET (cigarette-lighter type)

Removal

Remove the console.

Remove connectors from the power outlet housing.

Unscrew the large nut then remove the 12-volt power outlet.

Test

Remove power outlet.

Unplug the power outlet connectors.

Using the multimeter FLUKE 111 (P/N 529 035 868), measure the voltage between RED/BLACK and BLACK wires.



The obtained value should be between 12 and 14.5 Vdc.

- No voltage:
 - Check accessories fuse (20 A), connectors and wiring harness.
- Voltage is good:
 - After checking the accessories, change the power outlet.

Installation

The installation is the reverse of the removal procedure.

BEEPER (reverse alarm)

Removal

The beeper is located near the ignition coil.

Open the front hood, remove the windshield then remove screws retaining the accessories panel.

Unplug connector from beeper.

Unscrew retaining ring then remove beeper.

Test

NOTE: Before testing the beeper, make sure the connectors are installed on proper beeper tabs.

Section 07 ELECTRICAL SYSTEM

Subsection 04 (ACCESSORIES)

ENGINE TYPE	TAB LOCATION
All carburetor equipped engines except Power Tek	BEIGE/BLACK on positive tab BLACK on negative tab
SDI engines	RED/GREEN on positive tab BEIGE/BLACK on negative tab
Power Tek	RED/YELLOW on positive tab BEIGE/BLACK on negative tab

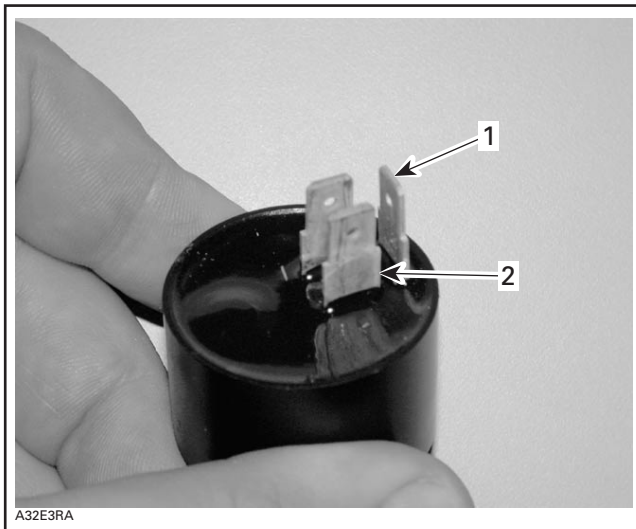

1. GREEN/RED wire on positive tab
2. BEIGE/BLACK wire on negative tab

Using jumper wires, connect battery positive post to beeper positive tab.

Connect battery negative post to beeper negative tab. See next photo.

CAUTION: To avoid beeper damage, ensure that polarity is respected.

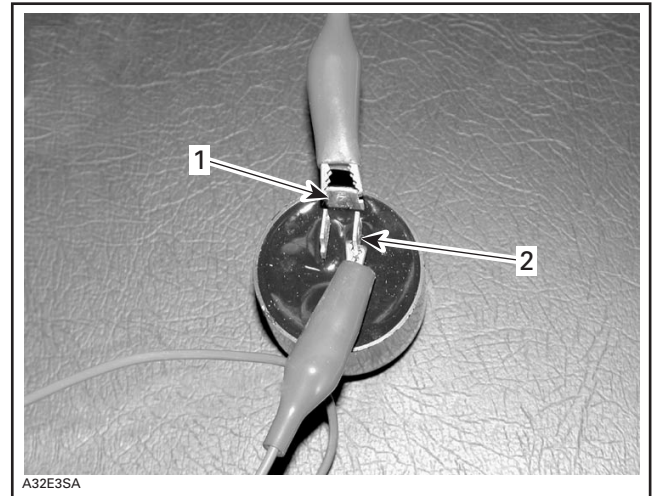

TYPICAL — 12-VOLT BATTERY PLUGGED TO BEEPER

1. Beeper positive tab
2. Beeper negative tab

A continuous sound should be heard. If not, replace the beeper with a new one.

If the beeper is good, check connectors, fuse and wiring harness.

Installation

To install beeper, reverse the removal procedure. Check connectors position.

ENGINE TEMPERATURE GAUGE

Test

Fan-cooled Models

Check if the speedometer works properly.

Check connector and wiring harness.

Check the engine temperature sensor on engine.

If all other parts work properly, replace the engine temperature gauge.

Liquid-cooled Models except SDI

Check fuses, connectors and harness.

Check condition of relay, refer to RELAY further in this section.

Check temperature sensor on engine.

Replace temperature gauge.

SDI Models

Check fuse, connectors and harness.

Check the condition of relay 2 by using the BUDS software.

Section 07 ELECTRICAL SYSTEM

Subsection 04 (ACCESSORIES)

Check temperature sensor.

Replace the gauge.

Removal

Remove the accessories panel.

Remove the ring around the gauge by pressing both tabs.

Unscrew the central nut and remove the support.

Unplug connector.

Remove gauge.

Installation

The installation is the reverse of removal procedure.

ELECTRIC FUEL GAUGE

Test

Liquid-cooled Models except SDI

Check fuses, connectors and harness.

Check the condition of the relay, refer to RELAY further in this section.

Check fuel sensor on fuel tank.

Replace electric fuel gauge.

SDI Models

Check fuse, connectors and harness.

Check relay 2 by using BUDS software.

Check fuel sensor on fuel tank.

Replace electric fuel gauge.

Removal

Remove the accessories panel.

Remove the ring around the gauge by pressing both tabs.

Unscrew the central nut and remove the support.

Unplug connector and remove gauge.

Installation

The installation is the reverse of the removal procedure.

HEADLAMP

Bulb Replacement

If any headlight bulb is burnt, proceed as follows.

Remove windshield.

Pull out steering support cap.

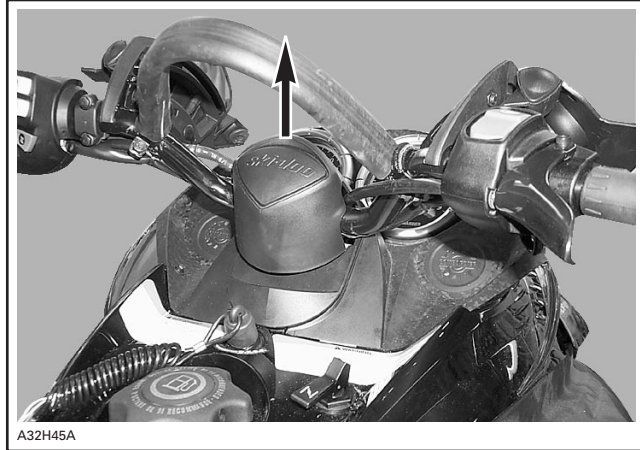

TYPICAL

Lift hood.

Pull up front console end cap.

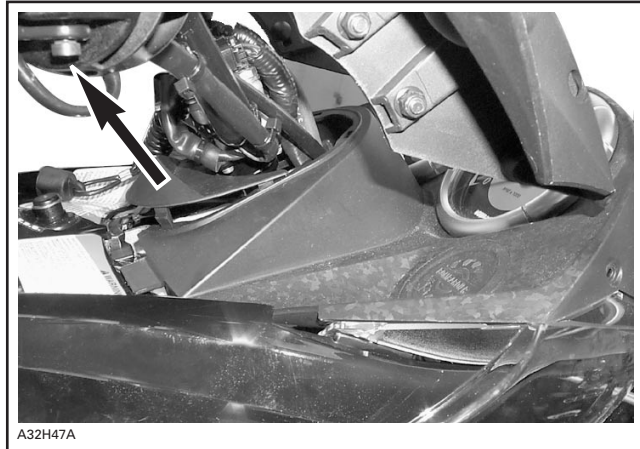

TYPICAL

Remove retaining screws and slightly lift accessories panel.

Section 07 ELECTRICAL SYSTEM

Subsection 04 (ACCESSORIES)

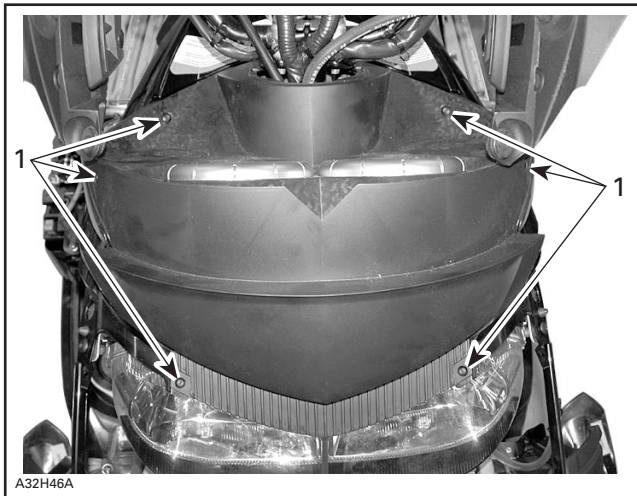

TYPICAL
1. Remove screws

Place the accessories panel out of way.
Unplug burnt bulb connector. Remove the rubber boot.
Turn bulb retainer ring counterclockwise to unlock. Detach the bulb and replace.



TYPICAL

CAUTION: Never touch glass portion of an halogen bulb with bare fingers, as it shortens its operating life. If by mistake glass is touched, clean it with isopropyl alcohol which will not leave a film on the bulb. After locking ring installation, ensure bulb is properly secured in place.

Properly reinstall removed parts.

Test

If the new bulb do not work correctly, check connector, wiring harness or HI-LOW beam switch.

Removal

Remove the accessories panel.

Disconnect headlamps.

On RH side of vehicle, remove the push nut then remove the headlamp housing.

Installation

Reverse the removal procedure.

HEADLAMP BEAM AIMING

Beam aiming is correct when center of high beam is 25 mm (1 in) below the headlamp horizontal center line, scribed on a test surface, 381 cm (12 ft 6 in) away.

Place the vehicle on a flat surface perpendicular to test surface (wall or screen) and 381 cm (12 ft 6 in) away from it.

Rider or equivalent weight must be on the vehicle.

Select **high** beam.

Measure headlamp center distance from ground. Scribe a line at this height on test surface (wall or screen). Light beam center should be 25 mm (1 in) below scribed line.

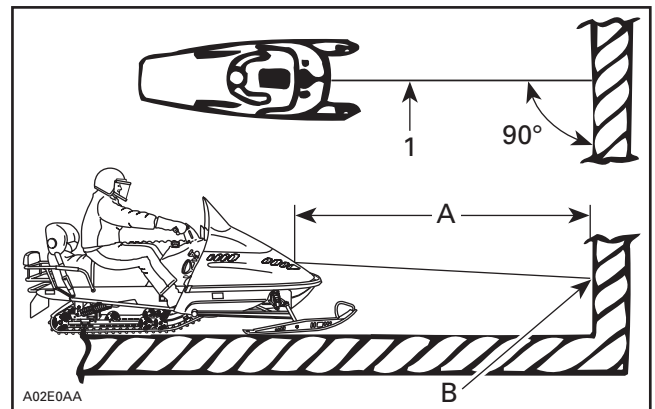

TYPICAL
1. Headlamp center line
A. 381 cm (12 ft 6 in)
B. 25 mm (1 in) below center line

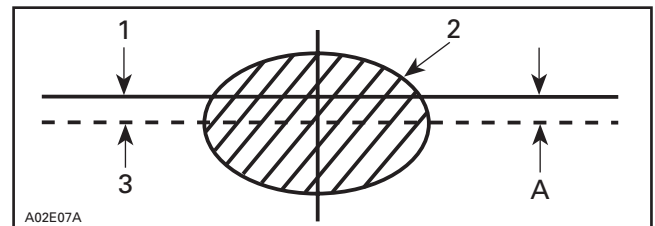

1. Headlamp horizontal
2. Light beam (high beam) (projected on the wall)
3. Light beam center
A. 25 mm (1 in)

Section 07 ELECTRICAL SYSTEM

Subsection 04 (ACCESSORIES)

HEATING ELEMENTS

NOTE: All measurements must be performed at 21°C (70°F).

Throttle Lever Heating Element

Current Measurement

HIGH INTENSITY	BROWN wire	0.23 A minimum
LOW INTENSITY	BROWN/YELLOW wire	0.13 A minimum

Handlebar Grip Heating Element

Resistance Measurement

All Models except SDI

INTENSITY	WIRES	OHMS
HIGH	BLACK and ORANGE/VIOLET	13.7 to 16.7*
LOW	BLACK and ORANGE	6.8 to 8.4*

SDI Models

INTENSITY	WIRES	OHMS
HIGH	BLACK and ORANGE/VIOLET	17 to 23.5*
LOW	BLACK and ORANGE	8.5 to 11.8*

*When measuring resistance at terminals the actual value will be half the measurement in table. The reason for that is the elements are connected in parallel. Therefore the total resistance is half the resistance of one element.

If the heating elements are good, check connectors and wiring harness.

RELAY

Voltage Test

RELAY		
TEST	Coil	Contact
WIRE COLOR	WHITE/GREEN and BLACK	BLACK/YELLOW and BLACK
RESISTANCE	—	—
VOLTAGE	10.5 to 13.5 Vdc	00.0 to 0.10 Vdc
NOTE	Engine idling (1500 to 1600 RPM)	Engine idling (1500 to 1600 RPM)

Continuity Test

Remove the relay from vehicle.

Using the multimeter FLUKE 111 (P/N 529 035 868), select the beeper position.



Position the RED probe on the terminal 30 and the BLACK probe on the terminal 87a.

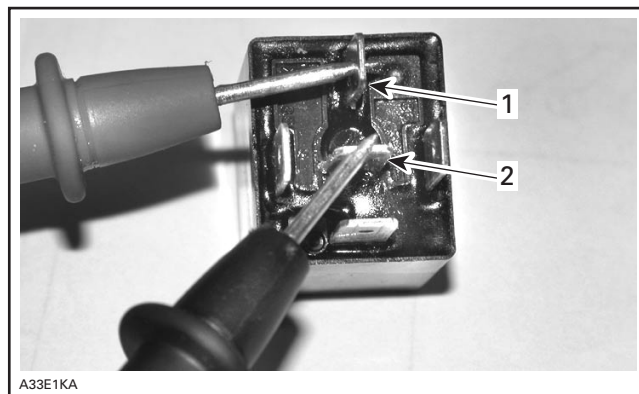

1. Terminal 30
2. Terminal 87a

A continuous signal should be audible. If not, replace the relay.

If a signal is audible, apply 12 volts on terminals 85 and 86 then place the RED probe on terminal 30 and the BLACK on the terminal 87.

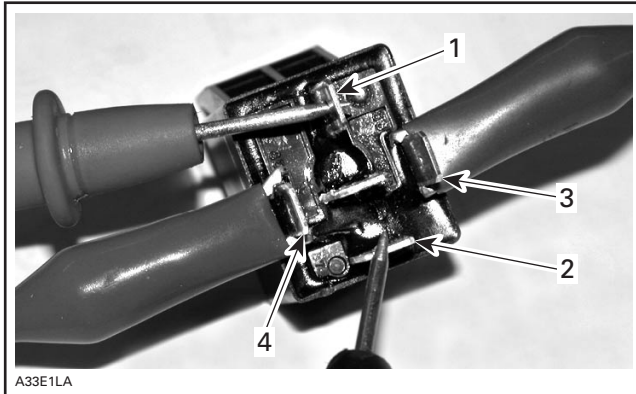

1. Terminal 30
2. Terminal 87
3. Terminal 85
4. Terminal 86

The continuous signal should be audible. If not, replace the relay.

SPEEDOMETER

Removal

Insert a little flat screwdriver into the slot at the bottom of the speedometer. Slightly, pry the speedometer and turn it clockwise then remove it from accessories panel.

Unplug connector.

Test

No lights and the needle does not move

Remove the speedometer. Apply 12 volts between pin 8 and pin 11. Place the positive probe on pin 8 and the negative on pin 11.

NOTE: Respect positive and negative positions if not the speedometer could be damaged.

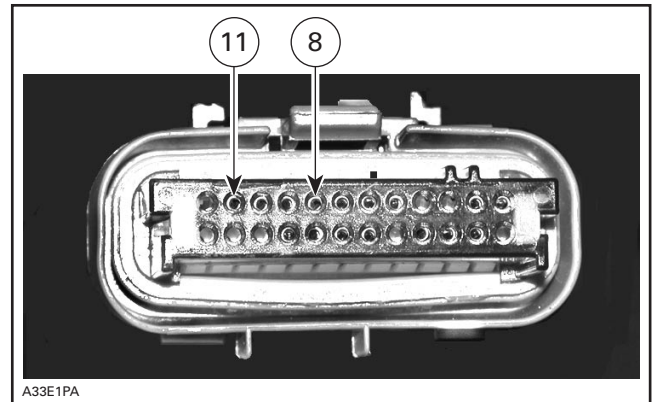

If the speedometer stays off, change it.

If the speedometer is lighted, check connector and wiring harness. Repair defective parts.

The speedometer is lighted but the needle does not move

Check the speed sensor and the wiring harness. If the speed sensor and the wiring harness are good, change the speedometer.

Installation

The installation is the reverse of the removal procedure.

SPEED SENSOR

Test

Fan-cooled Engines

To perform the speed sensor test, the engine must turn.

Liquid-cooled Engines

Install the supply harness (P/N 529 035 869) with the supply cable (P/N 529 035 997).

NOTE: Remove the headlight system fuse to save the battery during the test.

All Models

Static Test

Unplug the speed sensor connector.

Section 07 ELECTRICAL SYSTEM

Subsection 04 (ACCESSORIES)



Using the multimeter FLUKE 111 (P/N 529 035 868), measure the voltage between BLACK/BLUE and RED/GREY wires. The obtained value should be the battery voltage.

Measure the voltage between BLACK/BLUE and GREEN/WHITE wires. The obtained value should be ± 1 volt under battery voltage.

Dynamic Test

Install 3 pins in each speed sensor connector.

Install wire jumpers between pins.

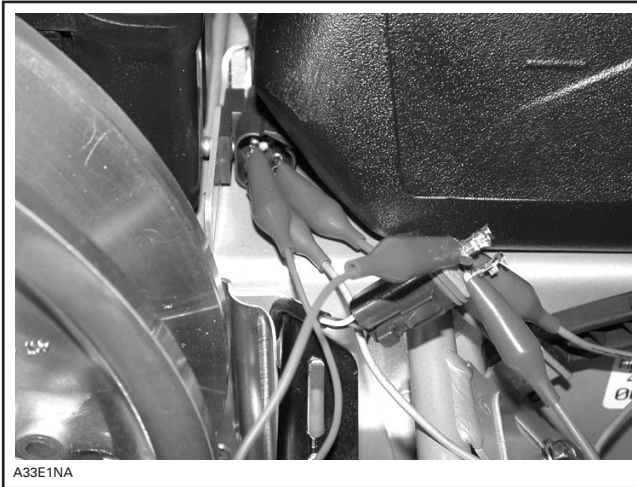

Lift the rear of the vehicle.

Connect multimeter probe on GREEN/WHITE and BLACK/BLUE wires.

Turn the track slowly. The voltage should be 12 volts then drop to O.L.

If the obtained value is out of specifications, change it.

TACHOMETER

Test

No light but the needle moves

The tachometer is supplied through the speedometer. Check the voltage between pins 9 and 10 of speedometer.

The obtained value should be the battery voltage. If not, check connections and wiring harness.

If the voltage is good, replace the tachometer.

The needle does not move

No lights, see speedometer

With lights, check RPM signal on pin 7.

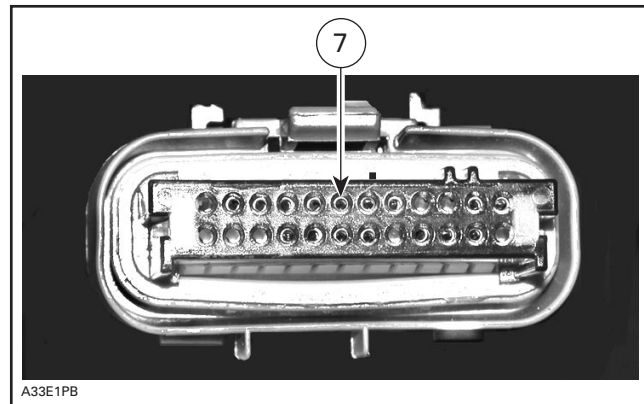

Crazy needle

Check wire connections on pin 18, 19, 20 and 21.

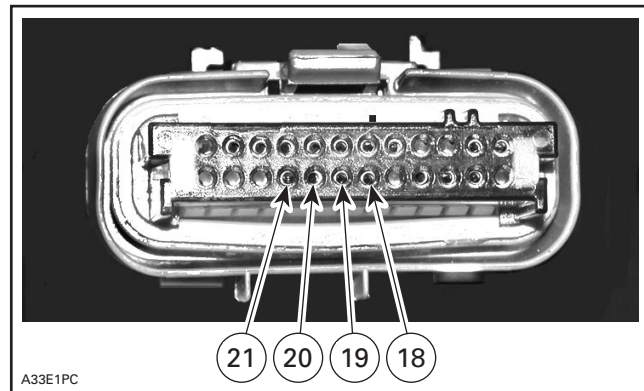

TAILLIGHT

Bulb Replacement

Unscrew lens screws to expose bulb.

Push the bulb in and hold while turning counter-clockwise to release.

Install the new bulb by first pushing in while turning clockwise.

Removal

Remove the radiator cover by removing the retaining screws. On all **GTX models** and the **EXPEDITION SPORT**, remove the seat studs and the seat fixation plates.

Disconnect taillight connector.

Remove the wires from connector. Open the connector on wire side then with a small tool extract the wires from the connector.

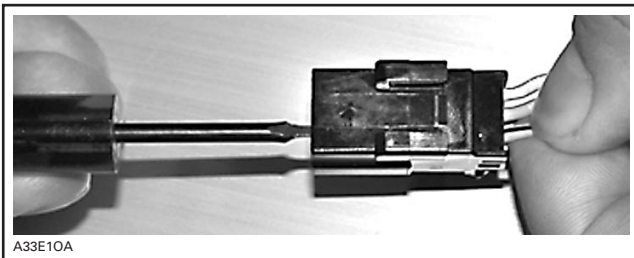

NOTE: Note the location of each wire.

Unscrew the screws retaining the rack to the side of frame.



Unscrew the other screws that attach the rack near the radiator.

Unscrew taillight lens and pull the wire.

Installation

The installation is the reverse of the removal procedure. On all **GTX models** and the **EXPEDITION SPORT**, pay attention to the following details.

Install the seat studs with the slot inside.

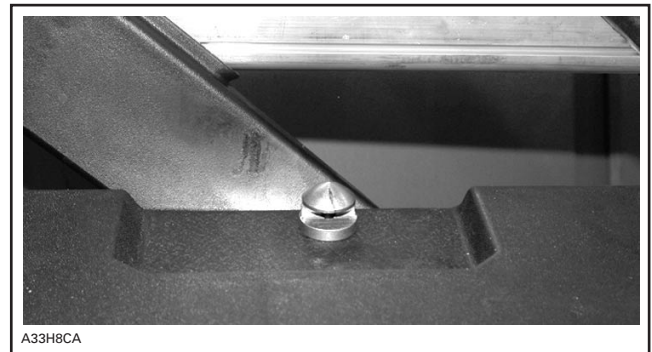

Torque the seat stud screws to 10 N•m (89 lbf•in).

VISOR OUTLET

Removal

Remove the console.

Unplug the visor connector.

Unscrew visor outlet.

Test

Unplug the visor connector.

Using the multimeter FLUKE 111 (P/N 529 035 868), check voltage between RED/YELLOW and BLACK wires. The obtained value should be ± 12 Vdc.

Before changing the visor outlet, try another accessory, if the accessory does not work, change visor outlet.

Installation

The installation is the reverse of the removal procedure.

DRIVE BELT

SERVICE TOOLS

Description	Part Number	Page
belt tension tester	414 348 200	320
drive belt tension adjuster	529 008 700	319

APPLICATION CHART

MODEL	PART NUMBER	MINIMUM WIDTH (wear limit) mm (in)
All 377 and 552 engines	415 060 600	32.3 (1-9/32)
All 593/HO/SDI engines	417 300 197	34.9 (1-3/8)
All 793 HO engines	417 300 166	35.3 (1-13/32)

INSPECTION

Inspect belt for cracks, fraying or abnormal wear (uneven wear, wear on one side, missing cogs, cracked fabric). If abnormal wear is noted, probable cause could be pulley misalignment, excessive RPM with frozen track, fast starts without warm-up period, burred or rusty sheave, oil on belt or distorted spare belt.

Check drive belt width. Replace the drive belt if width is under minimum recommended width (see table above).

Release parking brake. Vehicle must not creep when engine is idling. Otherwise, make sure that:

- idle speed is as specified
- proper belt is installed
- pulley center-to-center is as specified
- belt deflection is as specified.

ROTATION DIRECTION

The maximum drive belt life span is obtained when the drive belt is installed as shown. This will ensure that correct direction of rotation is respected.

CHECKING NEUTRAL FUNCTION

 WARNING

Always check neutral function when servicing.

Apply parking brake. Vehicle must be on the ground and on a plane level surface. No one should be in front of vehicle.

Attach vehicle tether cord to your clothing. Stand aside of vehicle, then start engine.

 WARNING

Do not sit on vehicle.

Section 08 DRIVE SYSTEM

Subsection 01 (DRIVE BELT)

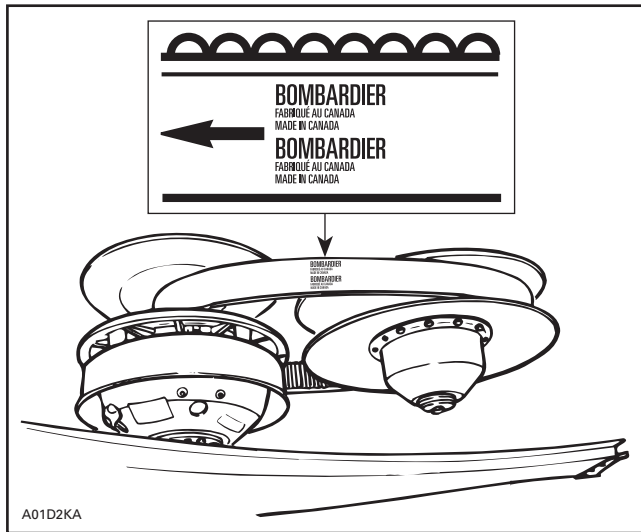

A01D2KA
CORRECT

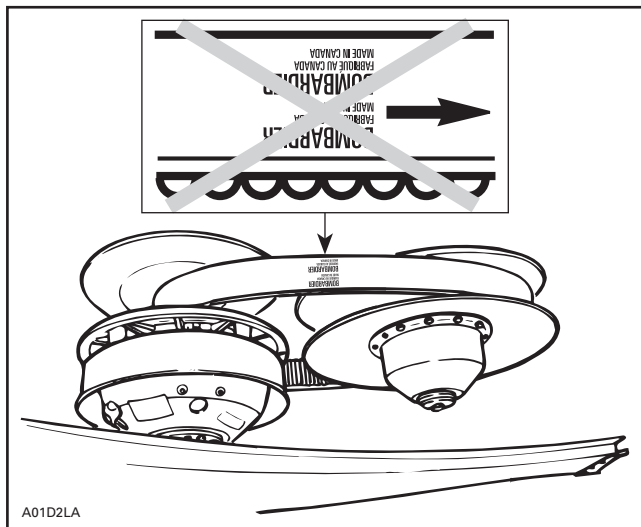

A01D2LA
INCORRECT

NOTE: For used drive belt, mark and reinstall in the same position.

DRIVE BELT HEIGHT MEASUREMENT AND ADJUSTMENT

Measurement

NOTE: The drive belt height measurement must be performed each time a new drive belt is installed.

NOTE: To obtain an accurate drive belt height measurement, it is suggested to allow a break-in period of 50 km (30 miles).

Before checking the belt height, ensure that a good-condition proper belt (refer to the APPLICATION CHART) is installed.

Adjust pulley distance and alignment. Refer to PULLEY DISTANCE AND ALIGNMENT.

To obtain maximum vehicle performance, the belt height must be adjusted according to specifications shown in the accompanying chart.

MODEL	BELT HEIGHT
All models	Top edge of drive belt cord should be flush with driven pulley edge.

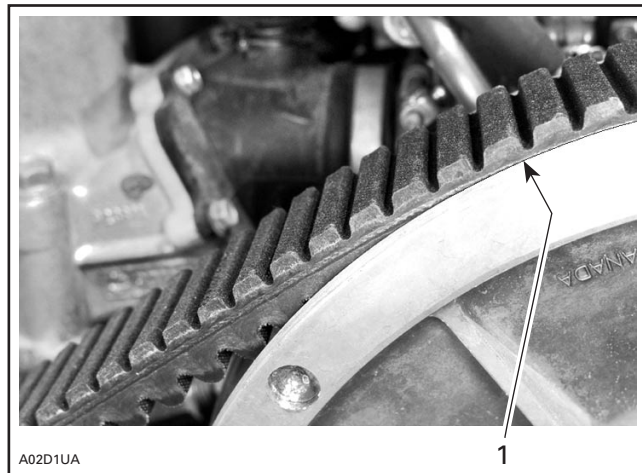

A02D1UA
1. Flush

Adjustment

Before adjusting the belt height, ensure that a good-condition proper belt (refer to the APPLICATION CHART) is installed.

Adjust pulley distance according to specification, refer to PULLEY DISTANCE AND ALIGNMENT.

Models Equipped with Formula Type Driven Pulley

Adjust drive belt height using Allen screws, as shown.

To lower belt in driven pulley: turn Allen screws clockwise.

To raise belt in driven pulley: turn Allen screws counterclockwise.

NOTE: Turn Allen screws 1/4 turn at a time, then rotate driven pulley to allow drive belt to settle in pulley. Check height, repeat as required.

Section 08 DRIVE SYSTEM
Subsection 01 (DRIVE BELT)

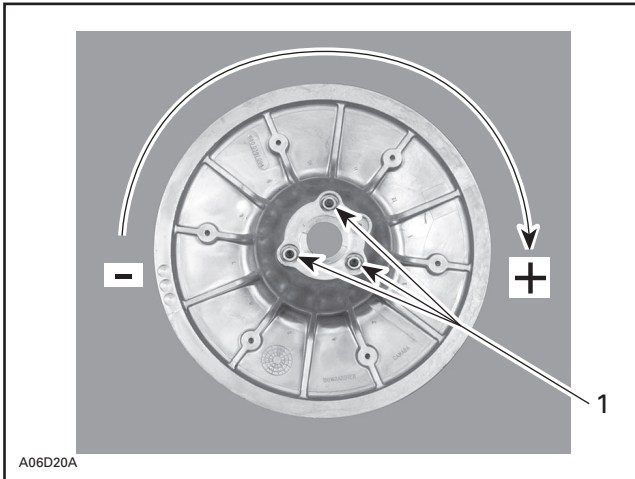

TYPICAL

- 1. Allen screws with jam nuts

Allen screws must be restrained while tightening jam nut to prevent throwing adjustment out. Use drive belt tension adjuster (P/N 529 008 700).

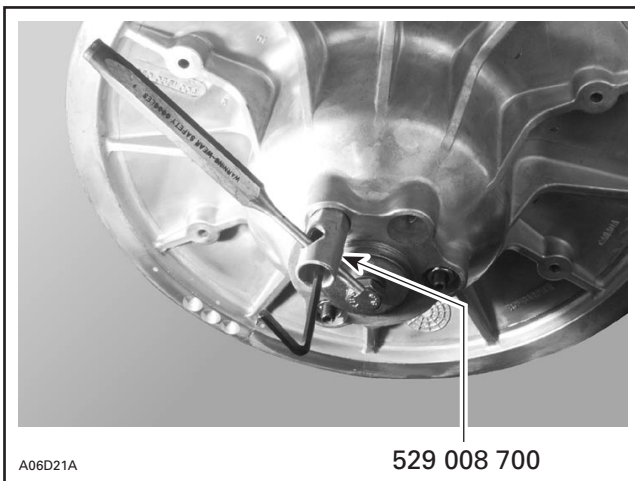

TYPICAL

Models Equipped with HPV Type Driven Pulley

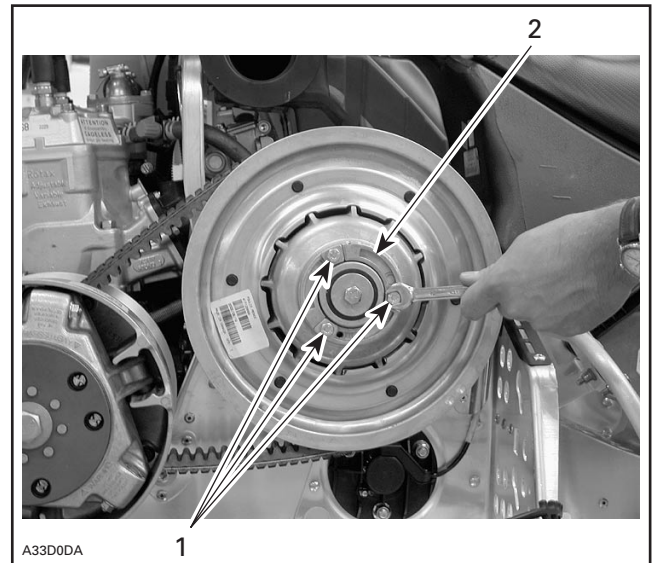

- 1. Screws
- 2. Adjustment ring

Loosen screws and turn adjustment ring as follows:

To lower belt in driven pulley: turn adjustment ring counterclockwise and tighten the screws.

To raise belt in driven pulley: turn ring clockwise and tighten the adjustment screws.

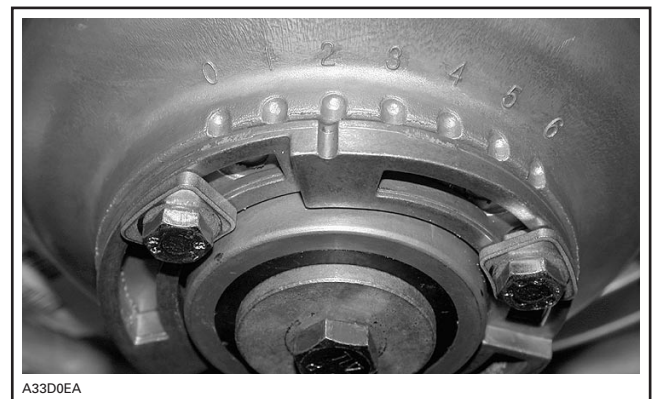

DRIVEN PULLEY NOTCHES

Turn the adjustment ring up to one notch, tighten the screws, then rotate driven pulley to allow drive belt to settle in pulley. Check height, if required the adjustment ring can be turned up to 1/4 or 1/2 the notch. Check height, repeat as required.

NOTE: Notches are there on the driven pulley for reference purpose only and the desired adjustment can be attained at any point.

Section 08 DRIVE SYSTEM

Subsection 01 (DRIVE BELT)

DRIVE BELT DEFLECTION MEASUREMENT (REFERENCE ONLY)

NOTE: The drive belt deflection measurement must be performed each time a new drive belt is installed.

NOTE: To obtain an accurate drive belt deflection measurement, it is suggested to allow a break-in period of 50 km (30 miles).

Before checking the belt deflection, ensure vehicle has the proper belt (refer to the APPLICATION CHART).

Adjust pulley distance and alignment. Refer to PULLEY DISTANCE AND ALIGNMENT.

To obtain maximum vehicle performance, the belt tension must be adjusted according to specifications shown in the accompanying chart.

MODEL	DEFLECTION † mm (in)	FORCE kg (lb)
All models	32 ± 5 (1.260 ± .197)	11.5 (25)

† FOR REFERENCE ONLY

To Check Tension

Position a reference rule on drive belt.

Wooden Stick and Spring Scale Method

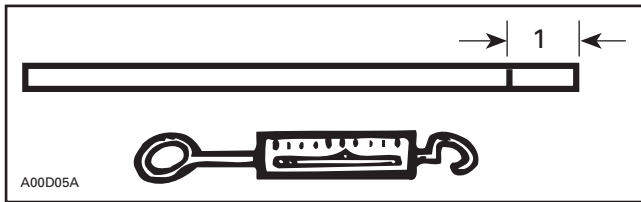

1. Mark specified deflection

Using spring scale and stick, apply specified force on drive belt halfway between pulleys as shown.

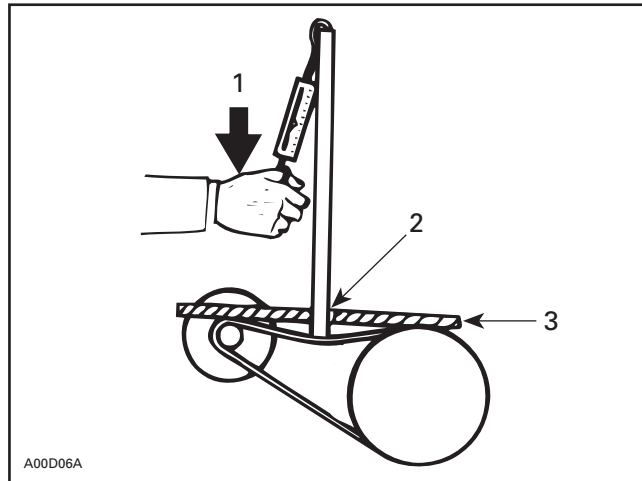

1. Force
2. Read deflection here
3. Reference rule

Or use the belt tension tester (P/N 414 348 200).

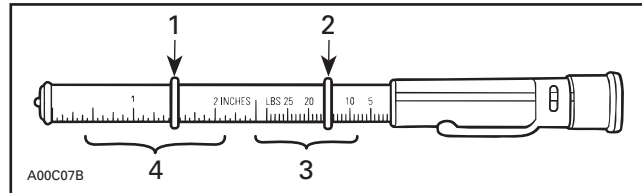

1. Lower O-ring
2. Upper O-ring
3. Force (read down)
4. Deflection (read up)

- 1) Slide lower O-ring of deflection scale to specified measure.
- 2) Slide upper O-ring to 0 (zero) on the force scale.
- 3) Apply pressure until lower O-ring is flush with edge of rule and read force on the upper scale at top edge of O-ring.

Section 08 DRIVE SYSTEM
Subsection 01 (DRIVE BELT)

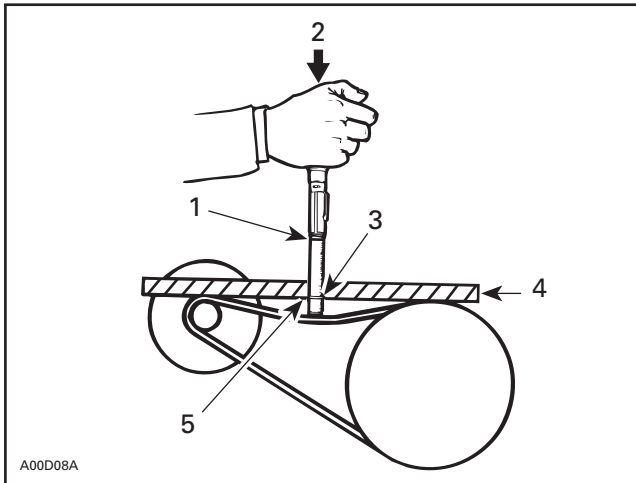

1. Upper O-ring — force
2. Force
3. Lower O-ring — deflection
4. Reference rule
5. Deflection

DRIVE PULLEY

SERVICE TOOLS

Description	Part Number	Page
bushing remover/installer	529 031 200	332
drive pulley holder	529 027 600	325, 327
drive pulley holder	529 035 674	329, 337
drive pulley puller.....	529 022 400	325–326, 329
slider shoe fork.....	529 005 500	330, 336
sliding half bushing remover/installer	529 035 931	332–333
spring compressor.....	529 035 524	330, 332–333, 335
spring cover tool.....	529 027 300	326

SERVICE PRODUCTS

Description	Part Number	Page
Loctite 271.....	293 800 005	327, 333
Loctite 609.....	413 703 100	333
pulley flange cleaner.....	413 711 809	327, 331, 333

Section 08 DRIVE SYSTEM
Subsection 02 (DRIVE PULLEY)

BOMBARDIER LITE

All Fan-cooled Models

NOTE: This drive pulley is lubrication free.

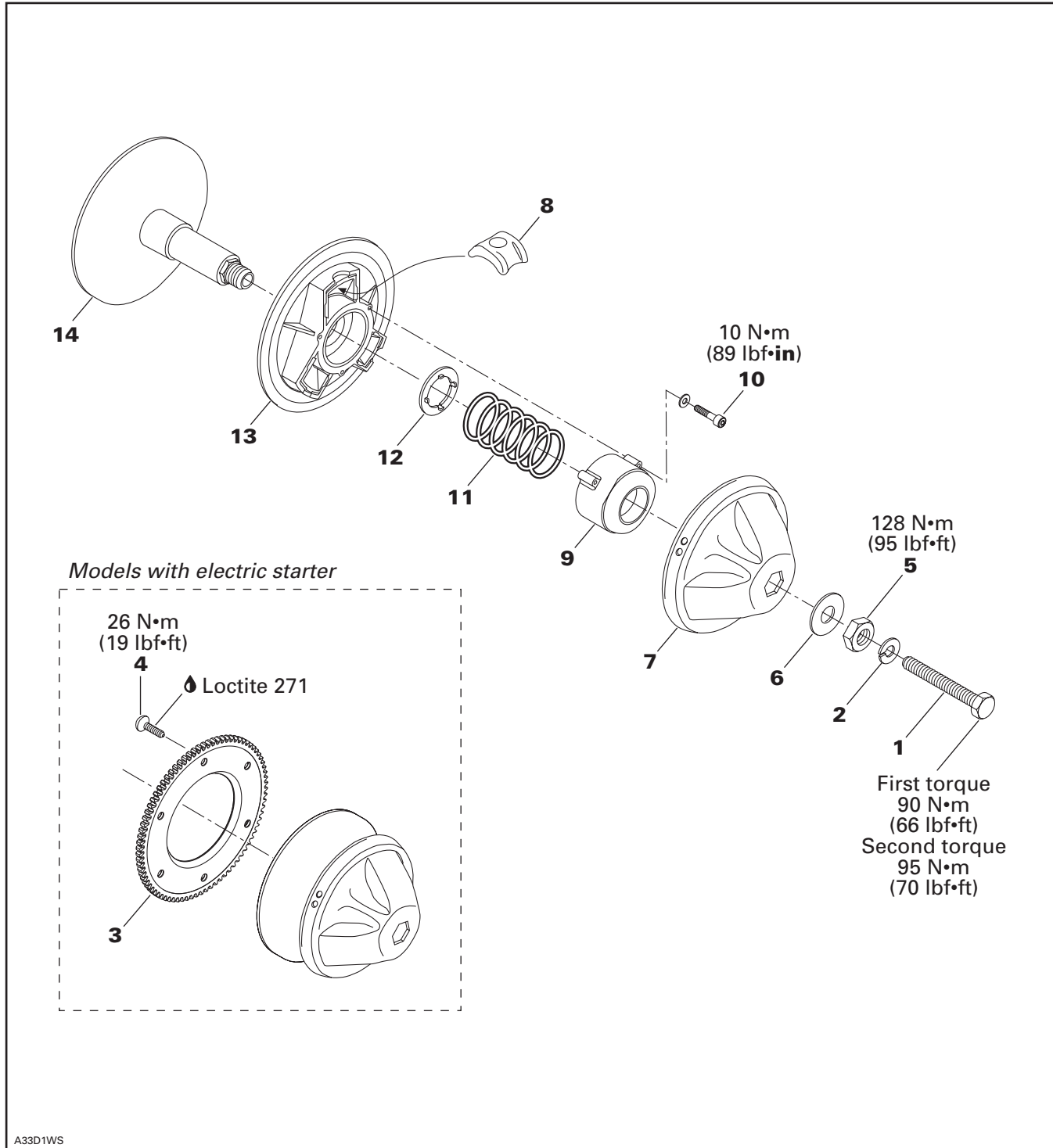

GENERAL

Some drive pulley components (return spring, calibration disk) can be changed to improve vehicle performance in high altitude regions. A service bulletin gives information about calibration according to altitude.

CAUTION: Such modifications should only be performed by experience mechanics since they can greatly affect vehicle performance.

WARNING

Any drive pulley repairs must be performed by an authorized Ski-Doo dealer. Subcomponent installation and assembly tolerances require strict adherence to procedures detailed.

REMOVAL

NOTE: If disassembling drive pulley, first straighten tab washer no. 6 then untighten nut no. 5.

WARNING

Never use an impact wrench to remove or install the drive pulley.

WARNING

The drive pulley assembly is a precisely balanced unit. Never replace parts with used parts from another drive pulley assembly.

Using the drive pulley holder (P/N 529 027 600), hold the drive pulley to remove the drive bolt no. 1 and its lock washer no. 2.

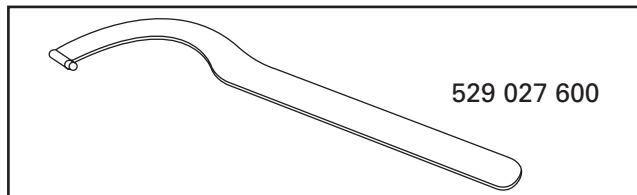

TYPICAL

With the drive pulley holder still installed, install the drive pulley puller (P/N 529 022 400) through the drive pulley.

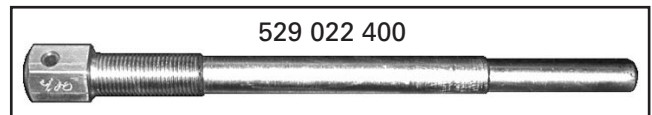

Hold the drive pulley and screw in the puller then remove drive pulley.



TYPICAL

DISASSEMBLY

To remove the ring gear no. 3, use a heat gun to break the threadlocker on ring gear screws no. 4 before disassembly.

Section 08 DRIVE SYSTEM

Subsection 02 (DRIVE PULLEY)

CAUTION: If another tool than a heat gun is used, do not exceed 150°C (300°F).

NOTE: The ring gear removal is not necessary to disassemble the drive pulley.

Unscrew nut **no. 5**. Remove washer **no. 6**.

Remove the drive pulley cap **no. 7**. Check for alignment marks for proper indexing at reassembly.

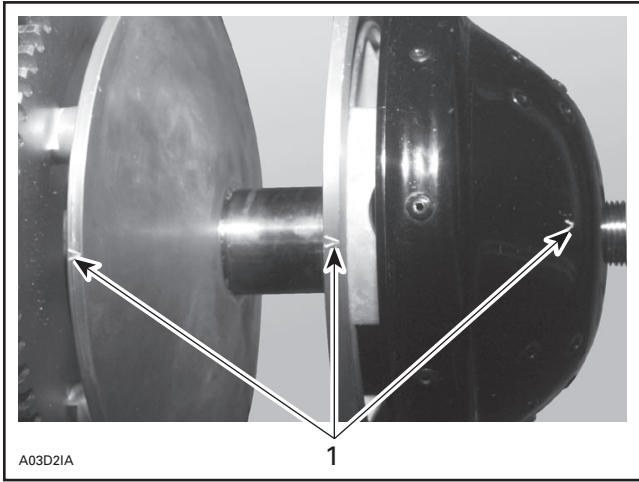

1. Alignment marks

Identify blocks **no. 8** and their respective positive positions for reassembly.

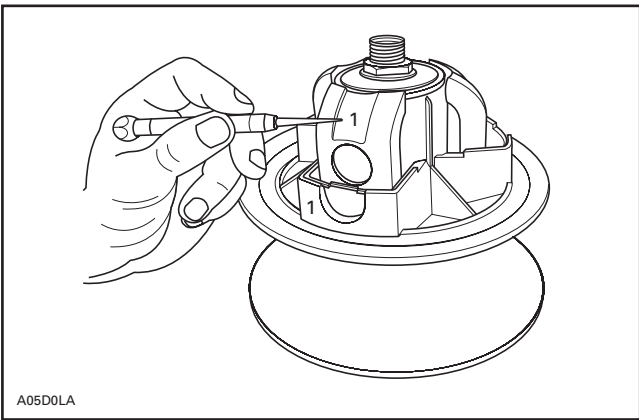

1. Identify

Remove blocks with their calibration weights.

Install the spring cover tool (P/N 529 027 300) with the drive pulley puller (P/N 529 022 400) on spring cover **no. 9**.

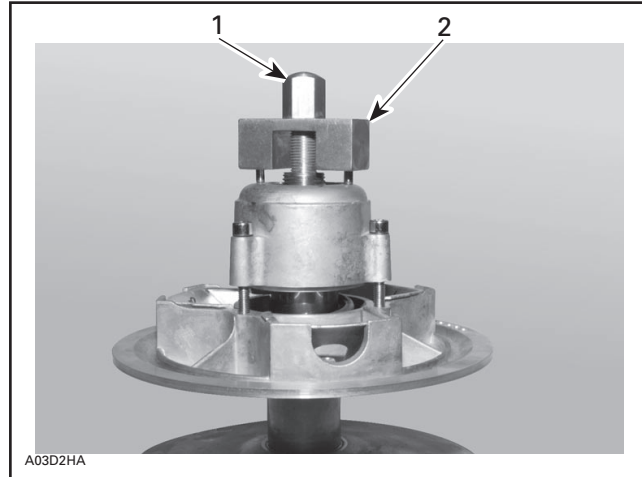
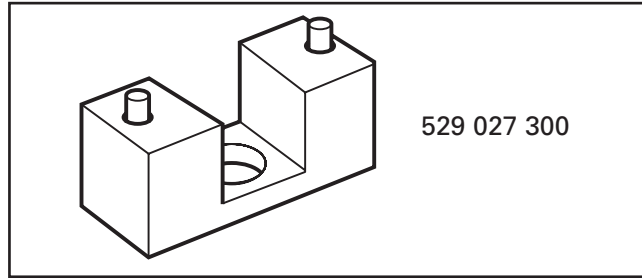

1. Drive pulley puller tool
2. Spring cover tool

Screw puller (hand tight) to hold spring cover and remove screws **no. 10** holding spring cover.

Slowly unscrew puller to release spring pressure.

Remove spring cover **no. 9**, spring **no. 11** and spring seat **no. 12**.

CLEANING

Clean pulley faces and shaft with fine steel wool and clean dry cloth. Clean sliding half bushing with clean dry cloth.

INSPECTION

Check surface of sliding half **no. 13** and fixed half **no. 14** for scratches, excessive wear or other damages. Replace if necessary.

Check sliding half for excessive lateral play and fixed half shaft for scratches. Replace as required.

ASSEMBLY

Install spring seat **no. 12** then the spring **no. 11** and its cover **no. 9**.

Section 08 DRIVE SYSTEM

Subsection 02 (DRIVE PULLEY)

Make sure to install blocks **no. 8** at their original position and with their curved end toward governor cup. See following illustration.



Install washer **no. 6** and nut **no. 5**.

Tighten nut to 128 N•m (95 lbf•ft).

To assemble ring gear **no. 3** on drive pulley, clean threads on back of fixed half **no. 14** and threads of screws **no. 4**.

Apply Loctite 271 (P/N 293 800 005) on screw threads and torque them to 26 N•m (19 lbf•ft).

INSTALLATION

Clean crankshaft taper and inner pulley taper with pulley flange cleaner (P/N 413 711 809).

Install the drive clutch bolt **no. 1** and its lock washer **no. 2**.

Hold the drive clutch with the drive pulley holder (P/N 529 027 600) then torque bolt to 90 N•m (66 lbf•ft).

Install drive belt and belt guard.

Raise and block the rear of the vehicle and support it with a mechanical stand.

⚠ WARNING

Make sure the track is free of particles that could be thrown out while track is rotating. Keep hands, tools, feet and clothing clear of track. Ensure nobody is standing near the vehicle.

Accelerate the vehicle at low speed (maximum 30 km/h (20 MPH)) and apply the brake, repeat 5 times.

Retorque bolt to 95 N•m (70 lbf•ft).

⚠ WARNING

After 10 hours of operation the transmission system of the vehicle must be inspected to ensure the retaining screw is properly torqued.

Section 08 DRIVE SYSTEM
Subsection 02 (DRIVE PULLEY)

TRA III

All Liquid-cooled Models

NOTE: These are lubrication free drive pulleys. Always refer to appropriate parts catalog for replacement part. Most parts of TRA III are not interchangeable with those of the TRA.

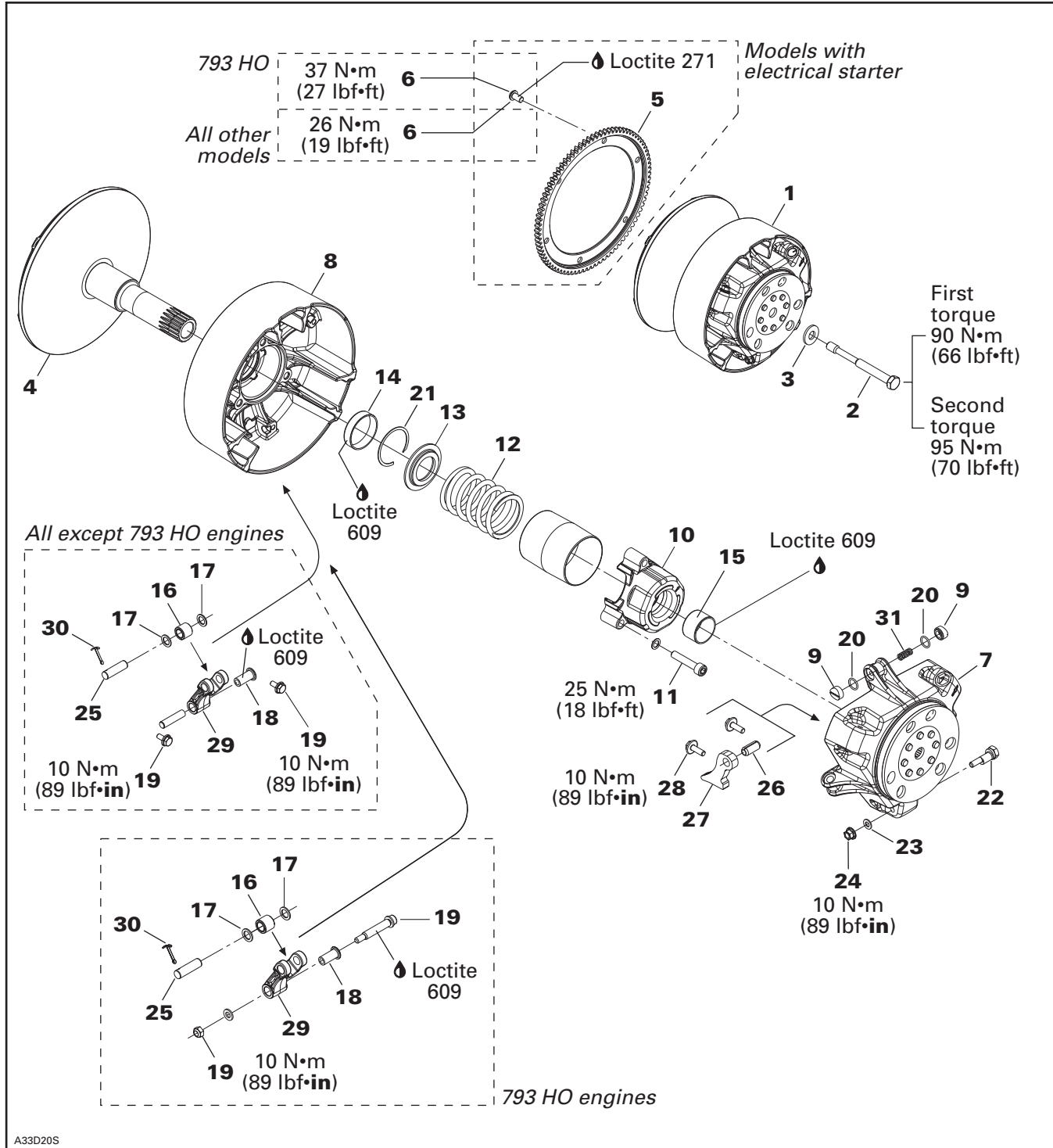

A33D20S

GENERAL

WARNING

Never use any type of impact wrench at drive pulley removal and installation. The use of impact wrench could damage the drive pulley and modify the calibration.

Some drive pulley components (return spring, ramp) can be changed to improve vehicle performance in high altitude regions. A service bulletin gives information about calibration according to altitude.

CAUTION: Such modifications should only be performed by experienced mechanics since they can greatly affect vehicle performance. Verify spring specifications before installation. Do not only refer to the spring color code.

NOTE: TRA drive pulley stands for Total Range Adjustable drive pulley.

WARNING

Any drive pulley repairs must be performed by an authorized Ski-Doo dealer. Subcomponent installation and assembly tolerances require strict adherence to procedures detailed.

REMOVAL

Remove drive belt.

Secure drive pulley **no. 1** with the drive pulley holder (P/N 529 035 674). Install it over a sliding half tower.

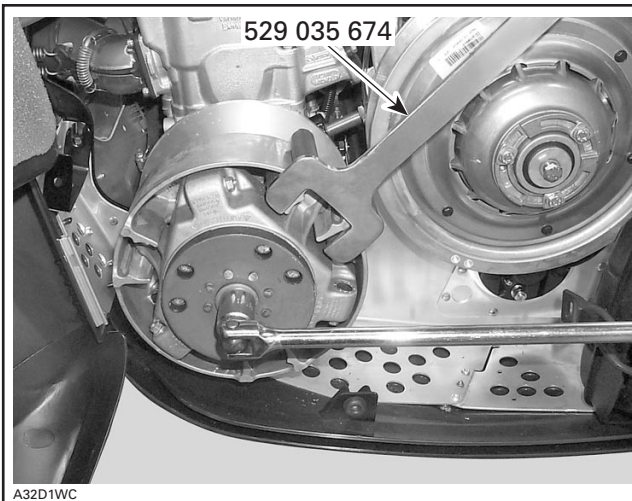

INSERT THE TOOL IN SLIDING FLANGE TOWER

Remove the drive pulley bolt **no. 2** and its conical spring washer **no. 3**.

To remove drive pulley **no. 1** and/or fixed half **no. 4** from engine, use the drive pulley puller (P/N 529 022 400).



Retain drive pulley with the drive pulley holder (P/N 529 035 674), and install the puller in pulley shaft then tighten.

CAUTION: These pulleys have metric threads. Do not use imperial threads puller. Always tighten puller by hand to ensure that the drive pulley has the same type of threads (metric vs imperial) prior to fully tightening.

DISASSEMBLY

Ring Gear

To remove the ring gear **no. 5**, use a heat gun to break the threadlocker on ring gear screws **no. 6** before disassembly.

CAUTION: If another tool than a heat gun is used, do not exceed 150°C (300°F).

Fixed Half

CAUTION: NEVER tap on governor cup **no. 7**.

To separate fixed half **no. 4** from sliding half **no. 8**, screw puller into fixed half shaft about 13 mm (1/2 in). Raise drive pulley and hold it by the sliding half while knocking on puller head to disengage fixed half.

Section 08 DRIVE SYSTEM

Subsection 02 (DRIVE PULLEY)

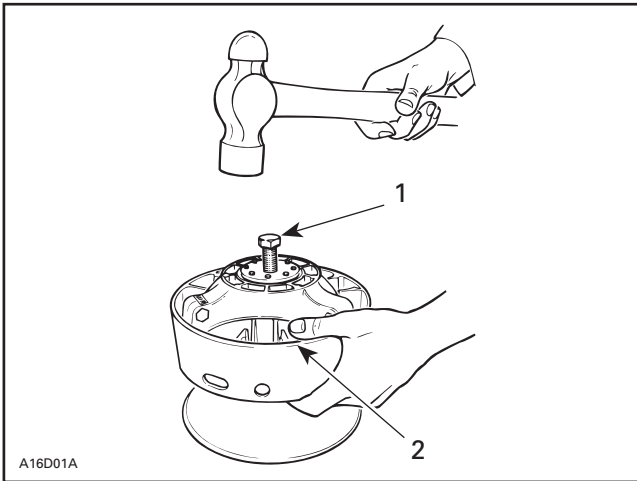

TYPICAL
 1. Puller
 2. Holding sliding half

NOTE: No components marking is required before disassembling this drive pulley since it has factory mark and arrows as indexing reference.

Slider Shoe and Governor Cup

Carefully lift governor cup no. 7 until slider shoes no. 9 come at their highest position into guides.

Hold a slider shoe set then carefully lift its housing and install a slider shoe fork (P/N 529 005 500). Proceed the same way for other housings lifting one at a time.

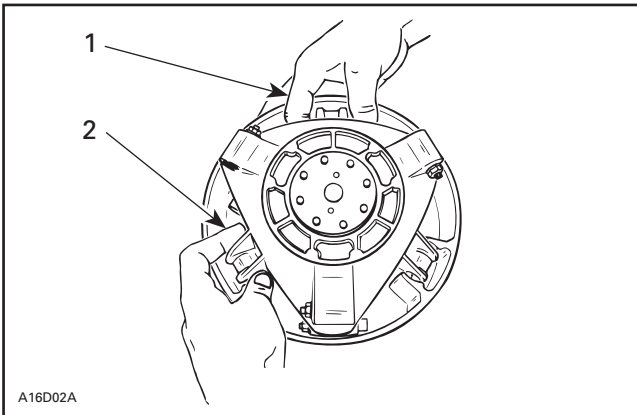

1. Hold slider shoes
 2. Lift one housing at a time

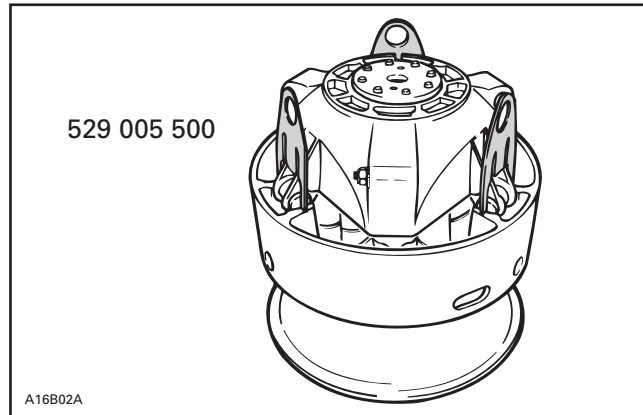

When all slider shoes are held with the forks, remove the governor cup.

Spring Cover

To remove the spring cover no. 10, always use the spring compressor (P/N 529 035 524). The spring cover is pushed by clutch spring pressure.

WARNING

Clutch spring is very strong. Never attempt to remove spring cover without the recommended tools.

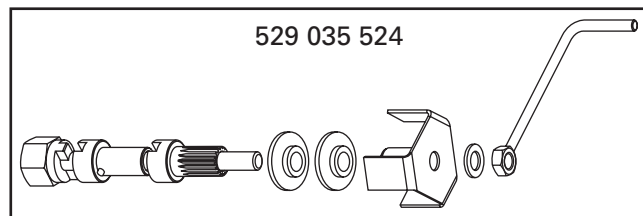

Install support guide of spring compressor in vice.

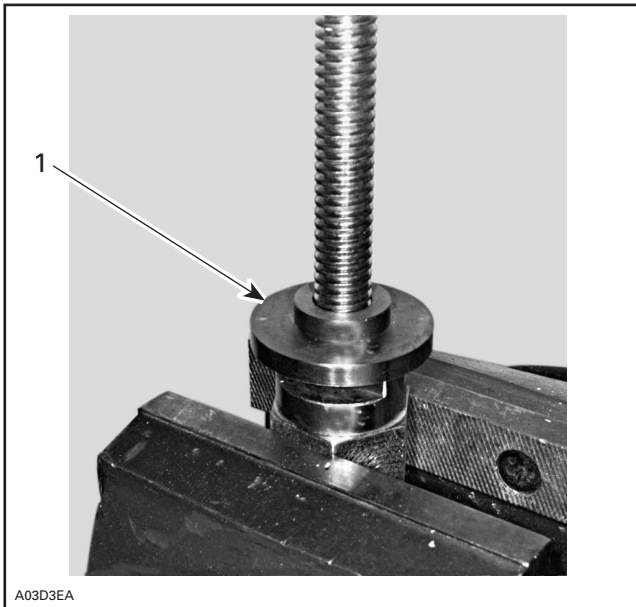

1. Support guide

Install sliding half no. 8 then a second support guide. These support guides will prevent bushing damages.

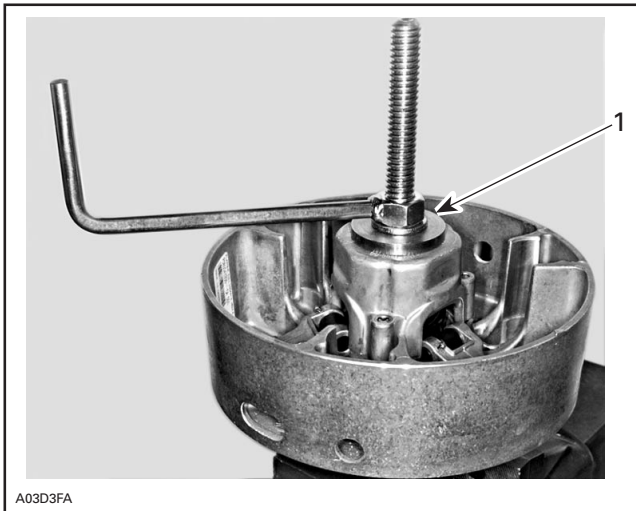

1. Support guide

Remove 3 Allen screws no. 11 retaining spring cover then unscrew compressor.

Remove spring cover, spring no. 12 and spring seat no. 13.

CLEANING

Fixed and Sliding Halves

Parts must be at room temperature before cleaning.

Clean pulley halves and shaft with fine steel wool and dry cloth.

Using a paper towel with pulley flange cleaner (P/N 413 711 809), clean crankshaft tapered end and the taper inside the fixed half of the drive pulley, crankshaft threads and retaining screw threads.

CAUTION: Avoid contact between cleaner and crankshaft seal because damage may occur.

Remove all hardened oil deposits that have baked on crankshaft and pulley tapered surfaces with coarse or medium steel wool and/or sand paper no. 600.

CAUTION: Do not use any other type of abrasive.

Reclean mounting surfaces with paper towel and cleaning solvent.

Wipe off the mounting surfaces with a clean, dry paper towel.

CAUTION: Mounting surfaces must be free of any oil, cleaner or towel residue.

Bushings

Clean sliding half bushing no. 14 and spring cover bushing no. 15 only with a petrol-based cleaner.

CAUTION: Do not use acetone to clean bushing.

INSPECTION

Drive pulley should be inspected annually.

Thrust Washer and Roller

Check rollers no. 16 for roundness of external diameter. Check thrust washers no. 17 for thickness wear. Replace as required.

CAUTION: Ensure rollers are in good condition. Replace as required.

Lever Bolt and Flanged Bushing

Check the flanged bushings no. 18 for wear. Replace if necessary.

Section 08 DRIVE SYSTEM

Subsection 02 (DRIVE PULLEY)

Check lever bolts no. 19 for wear, replace as required.

O-ring and Slider Shoe

Check if O-rings no. 20 are cracked, cut or crushed. Replace as required.

Check slider shoes no. 9 for wear. Replace if groove is not apparent on top.

Fixed Half and Governor Cup

Inspect splines and free play between both parts. Maximum free play is 0.5 mm (.020 in) measured at calibration screw radius. Replace if required.

Sliding Half and Spring Cover Bushings

Visually inspect coating of bushings no. 14 and no. 15. Replace if worn.

Sliding Half Bushing Replacement

NOTE: In case of worn out bushing, it is advisable to replace whole sliding half assembly as replacing just the bushing may reduce the drive pulley performance.

Remove circlip no. 21 from the sliding half.

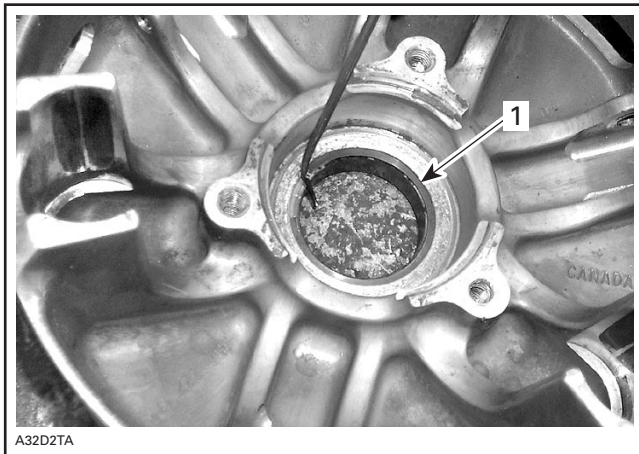

1. Circlip

Secure the spring compressor (P/N 529 035 524) in a vice. Mount the bushing remover/installer (P/N 529 031 200) and the sliding half assembly on it.

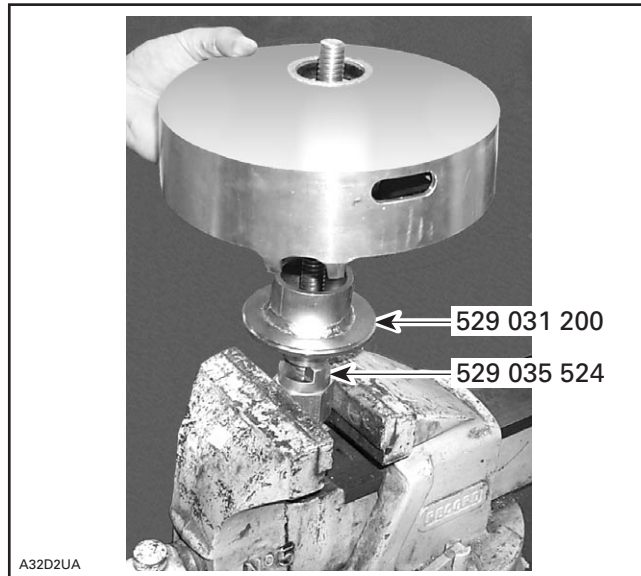

Use the sliding half bushing remover/installer (P/N 529 031 200) to press out old bushing.

NOTE: Make sure to use the tool as marked; to remove the bushing press using the side marked "OUT", as shown below in the picture.

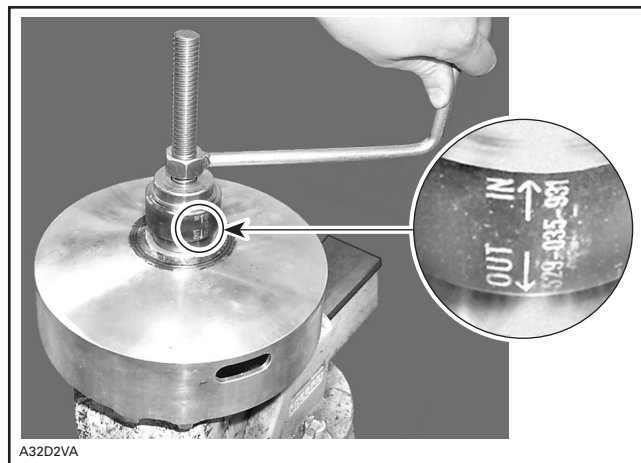

Use a soft sand paper to clean sliding half bushing mounting surface.

Section 08 DRIVE SYSTEM

Subsection 02 (DRIVE PULLEY)



Clean sliding half bushing mounting surface with pulley flange cleaner (P/N 413 711 809).

To install a new bushing, secure the spring compressor (P/N 529 035 524) in a vice and mount the sliding half.

Apply Loctite 609 (P/N 413 703 100) on the outside of bushing face then insert the bushing from inner side of sliding half.

Mount the sliding half bushing remover/installer (P/N 529 035 931) with side marked "IN" to press in a new bushing.



NOTE: Make sure that the bushing is well seated on the sliding half.

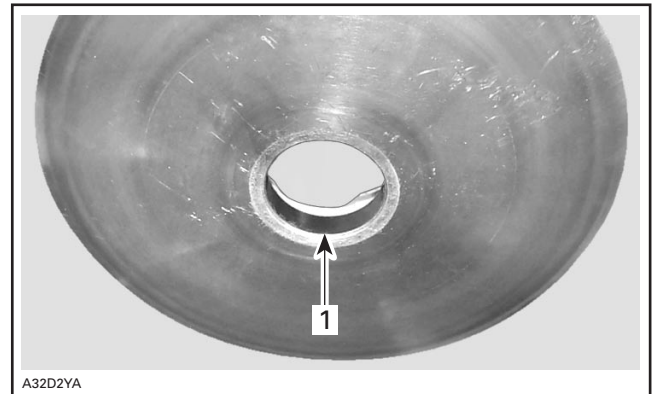

1. Bushing

Install the circlip.



1. Circlip

Spring Cover Bushing Replacement

Under normal use there is no need to replace this bushing no. 15.

In case of replacement, it's recommended to replace spring cover ass'y.

ASSEMBLY

NOTE: This drive pulley is lubrication free. Do not lubricate any component.

Ring Gear

Clean ring gear no. 5 and the inner threads of fixed half no. 4.

Apply Loctite 271 (P/N 293 800 005) on ring gear screw threads and then torque.

Section 08 DRIVE SYSTEM

Subsection 02 (DRIVE PULLEY)

RING GEAR ON TRA III	
ENGINES	TORQUE
All models except 793 HO	37 N•m (27 lbf•ft)
All 793 HO	27 N•m (20 lbf•ft)

Calibration Screw, Washer and Locking Nut

When installing calibration screw **no. 22**, make sure to install washer **no. 23** as shown.

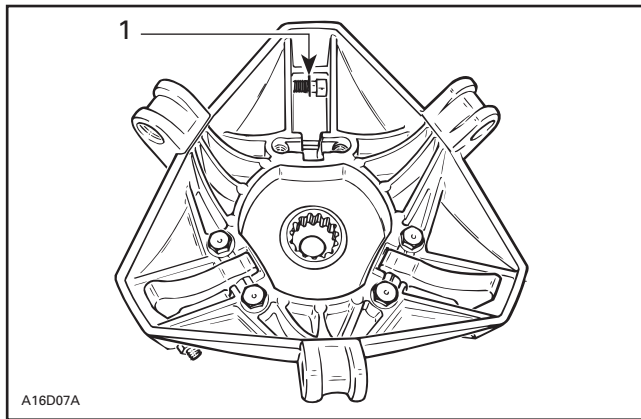

TYPICAL
1. Washer

The calibration screws should be installed at the following position.

CALIBRATION SCREW		
MODELS	ENGINES	POSITION
GSX	593 and 593 HO SDI	4
	593 HO and 793 HO	3
GTX	593 and 593 HO SDI	4
	593 HO and 793 HO	3
MXZ	593, 593 HO and 793 HO	3
	593 HO SDI	4
Summit	593 HO and 793 HO	1

Torque locking nut **no. 24** to 10 N•m (89 lbf•in).

Pin

Always use the same type of pin **no. 25** as originally installed when servicing. Different types have different weights for calibration purpose. Refer to TECHNICAL DATA.

Dowel Tube and Ramp

Insert dowel tube **no. 26** from chamfered side. Make sure ramp **no. 27** is centered on dowel tube.

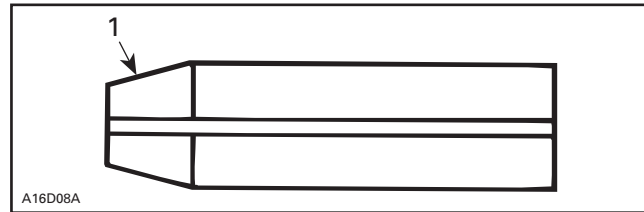

1. Chamfered side

Position dowel tube split at the angle A.

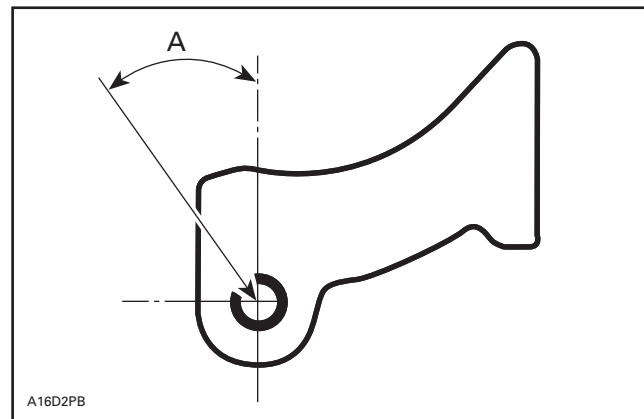

MODEL	ANGLE (A)
With TRA III	45 ± 3°

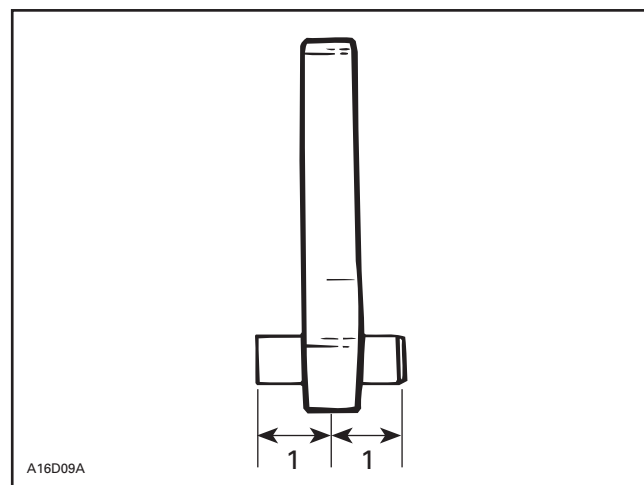

1. Equal distance

Torque screws **no. 28** to 10 N•m (89 lbf•in).

Lever, Nut and Cotter Pin

NOTE: While installing lever no. 29 make sure that the curved sides of the levers are outwards as shown.



Always install lever assemblies so that cotter pins no. 30 are on the shown side. Besides install cotter pin head on top when lever is sat at bottom of sliding half. Bend cotter pin ends to sit perfectly against lever.

⚠ WARNING

Whenever replacing centrifugal levers, always replace all 3 at the same time. Otherwise, drive pulley misbalancing will occur because of levers difference.

CAUTION: Lever assemblies must be installed so that cotter pins are on the same side.

793 HO Engine Equipped Models Only

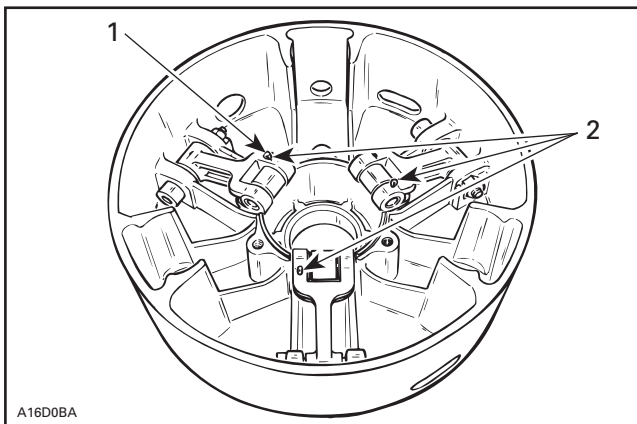

TYPICAL
 1. Head on top
 2. All on the same side

593 /HO/SDI Engine Equipped Models Only

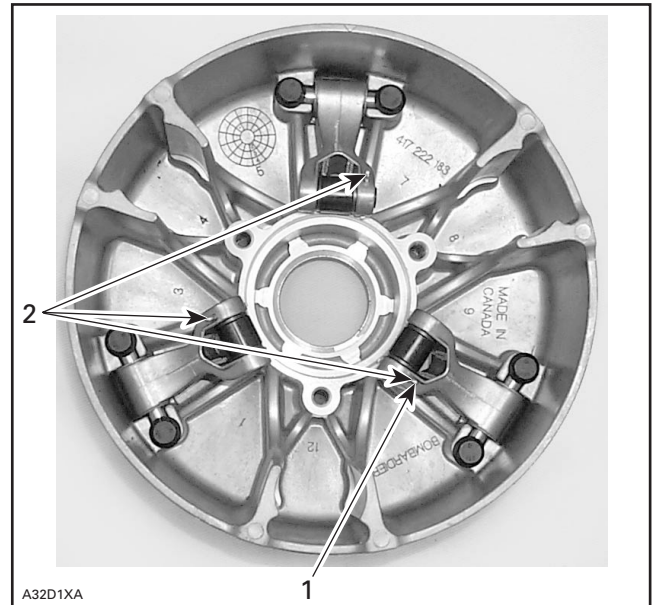

1. Head on top
 2. All on the same side

All Models

Torque screws no. 19 as per the exploded view.

CAUTION: Lever ass'y and rollers must move easily after installation.

Fixed Half, Sliding Half, Spring and Spring Cover

To install spring cover, use spring compressor (P/N 529 035 524).

Assemble fixed and sliding halves. Note that fixed halves have different taper angle. Match taper angle with crankshaft.

Lift sliding half against spring cover and align spring cover arrow with sliding half mark.

Section 08 DRIVE SYSTEM
Subsection 02 (DRIVE PULLEY)

793 HO Engine Equipped Models

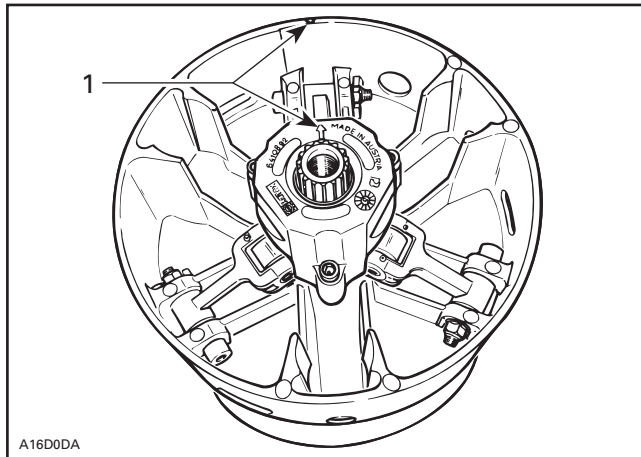

A16D0DA

TYPICAL
 1. Align

593/HO/SDI Engine Equipped Models Only

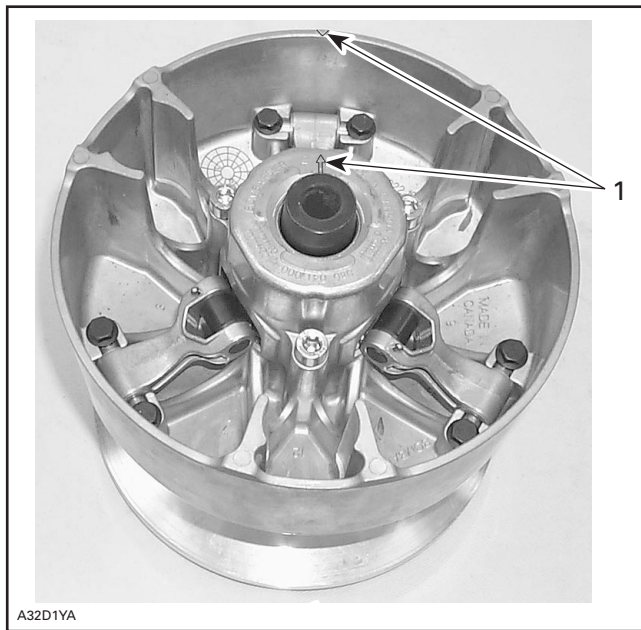

A32D1YA

1. Align

All Models

Tighten screws no. 11 to proper torque as mentioned in exploded view.

Sliding Half, Slider Shoe and Governor Cup

To install governor cup, use the slider shoe fork (P/N 529 005 500) following tool:

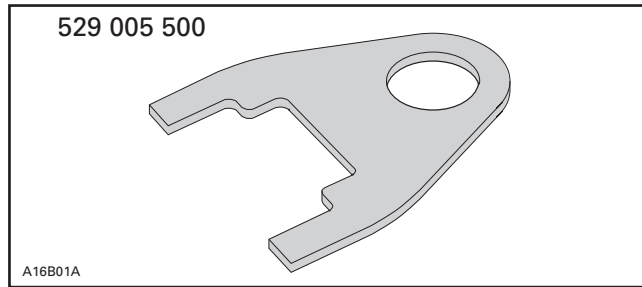

A16B01A

Insert spring no. 31 and slider shoes no. 9 into governor cup no. 7 so that groove in each slider shoe is vertical to properly slide in guides.

CAUTION: Make sure O-rings are installed on slider shoes.

Install a slider shoe fork into slider shoe grooves to maintain them for governor cup installation. Proceed on 3 set of slider shoes.

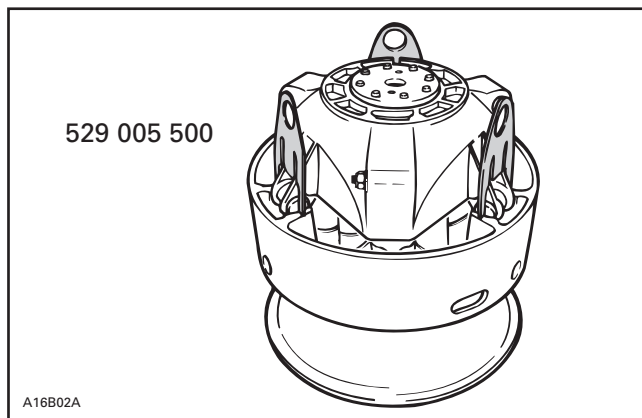

A16B02A

TYPICAL

Make sure to align governor cup arrow with sliding half and fixed half mark.

NOTE: If fixed half has no mark, align governor cup mark with **segment no. 1** of inner half. Segments are identified on engine side.

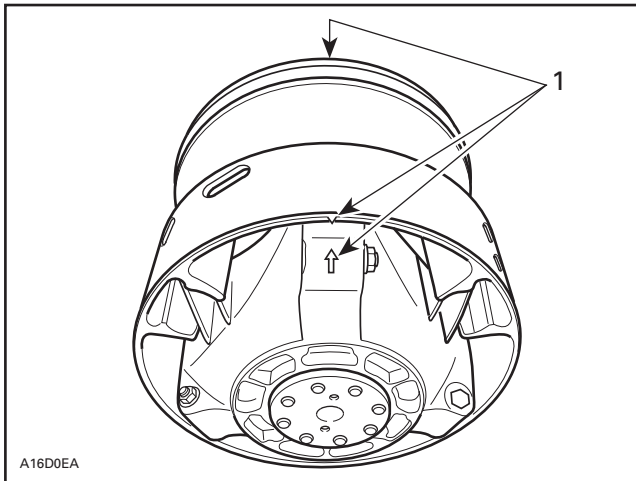

TYPICAL
1. Align

Carefully slide governor cup into sliding half. Align mark of governor cup with mark of fixed half.

Remove forks and push governor cup so that its splines engage with fixed half shaft splines.

INSTALLATION

⚠ WARNING

Do not apply antiseize or any lubricant on crankshaft and drive pulley tapers.

⚠ WARNING

Never use any type of impact wrench at drive pulley removal and installation.

Clean mounting surfaces as described in CLEANING above.

Drive Pulley Ass'y

The following installation procedure must be strictly adhered.

Install drive pulley on crankshaft extension.

Install a new conical spring washer **no. 3** with its concave side towards drive pulley then install drive pulley bolt **no. 2**.

⚠ WARNING

Never substitute conical spring washer and/or bolt with jobber ones. Always use BRP genuine parts for this particular case.

Use the drive pulley holder (P/N 529 035 674). See removal procedure.

Torque screw to 90 N•m (66 lbf•ft).

Install drive belt and guard.

Raise and block the rear of the vehicle and support it with a mechanical stand.

⚠ WARNING

Ensure that the track is free of particles which could be thrown out while track is rotating. Keep hands, tools, feet and clothing clear of track. Ensure nobody is standing near the vehicle.

Accelerate the vehicle at low speed (maximum 30 km/h (20 MPH)) and apply the brake, repeat 5 times.

Retorque screw to 95 N•m (70 lbf•ft).

⚠ WARNING

After 10 hours of operation the transmission system of the vehicle must be inspected to ensure the retaining screw is properly torqued.

DRIVE PULLEY ADJUSTMENT

The drive pulley is factory calibrated to transmit maximum engine power at a predefined RPM. Factors such as ambient temperature, altitude or surface condition may vary this critical engine RPM thus affecting snowmobile efficiency.

This adjustable drive pulley allows setting maximum engine RPM in the vehicle to maintain maximum power.

Calibration screws should be adjusted so that actual maximum engine RPM in vehicle matches the maximum horsepower RPM given in TECHNICAL DATA.

NOTE: Use precision digital tachometer for engine RPM adjustment.

NOTE: The adjustment has an effect on high RPM only.

To adjust, modify ramp end position by turning calibration screws.

Section 08 DRIVE SYSTEM

Subsection 02 (DRIVE PULLEY)

Calibration screw has a notch on top of its head.

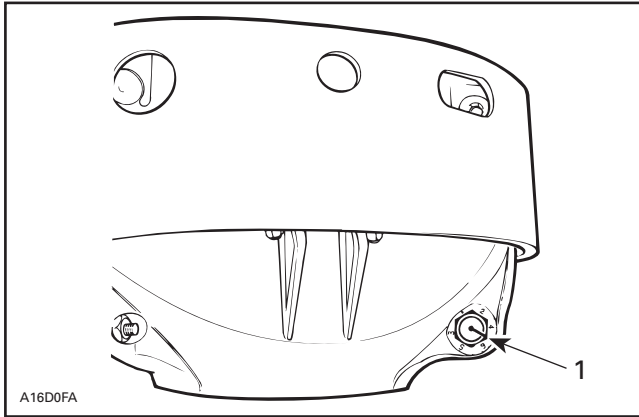

1. Notch

Governor cup has 6 positions numbered 2 to 6. Note that in position 1 there is no stamped number (due to its location on casting).

See TECHNICAL DATA for original setting.

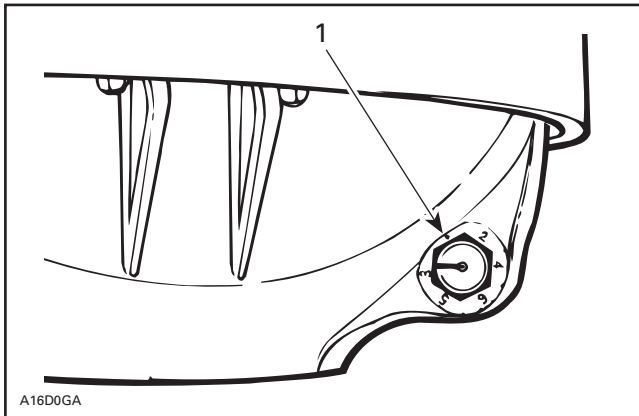

1. Position 1 (not numbered)

Each number modifies maximum engine RPM by about 200 RPM.

Lower numbers decrease engine RPM in steps of 200 RPM and higher numbers increase it in steps of 200 RPM.

Example:

Calibration screw is set at position 3 and is changed to position 5. So maximum engine RPM is increased by about 400 RPM.

To Adjust:

Just loosen locking nut enough to pull calibration screw **partially** out and adjust to desired position. Do not completely remove the locking nut. Torque locking nuts to 10 N•m (89 lbf•in).

CAUTION: Do not completely remove calibration screw otherwise its inside washer will fall off.

CAUTION: Always adjust all 3 calibration screws and make sure they are all set at the same number.

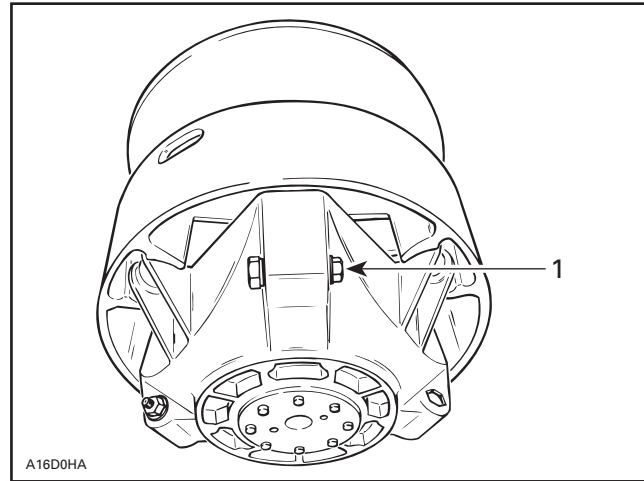

TYPICAL

1. Loosen just enough to permit rotating of calibration screw

DRIVEN PULLEY

SERVICE TOOLS

Description	Part Number	Page
clutch spring compressor	529 035 524	341–343, 346
large bushing extractor	529 031 100	342
large bushing extractor	529 035 575	342
spring scale hook.....	529 006 500	344, 347

SERVICE PRODUCTS

Description	Part Number	Page
Loctite 609.....	413 703 100	342
Loctite antiseize lubricant	293 800 070	343, 347
pulley flange cleaner.....	413 711 809	341, 346

Section 08 DRIVE SYSTEM
Subsection 03 (DRIVEN PULLEY)

FORMULA RER AND FORMULA VSA-R

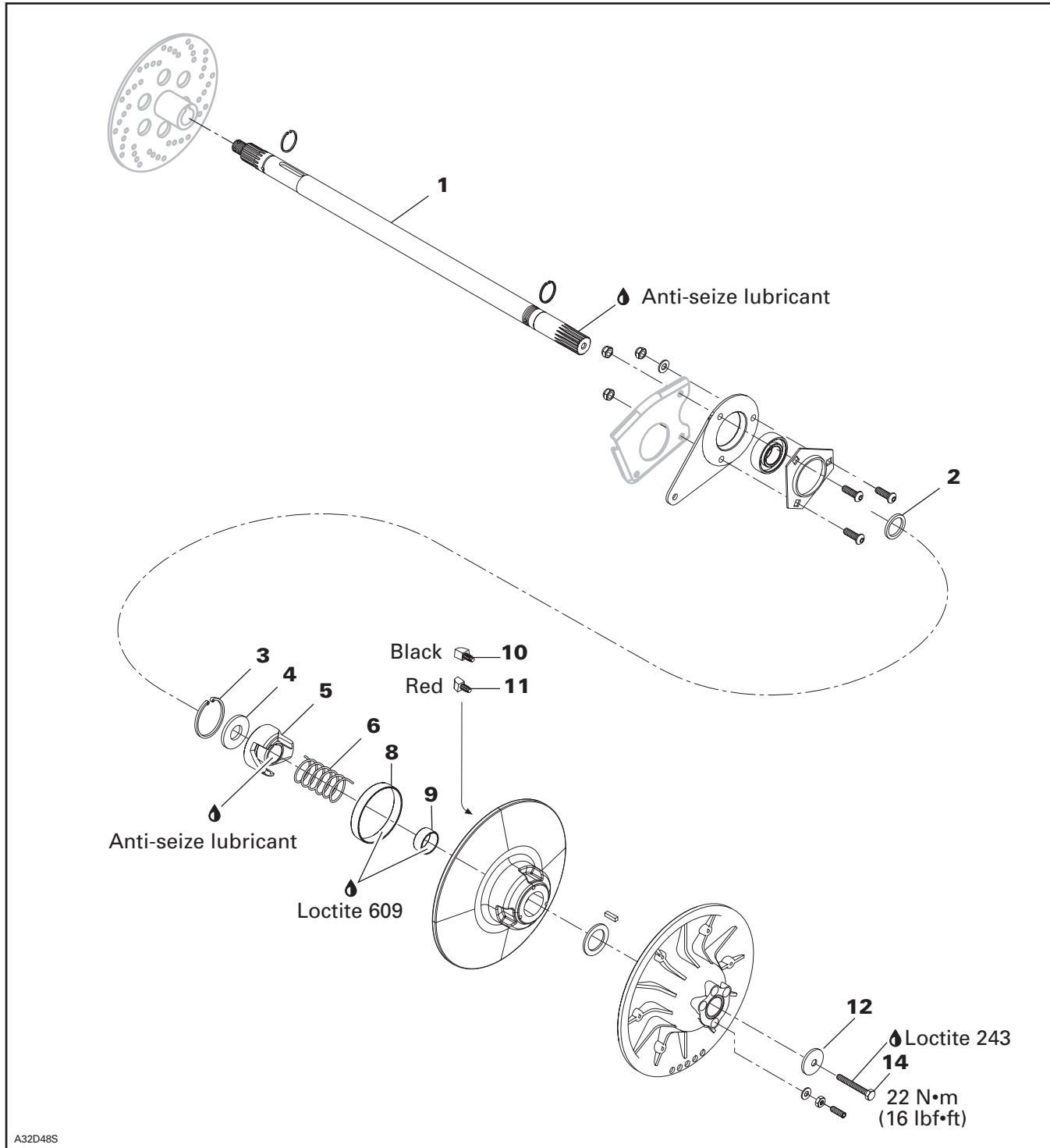

REMOVAL

Remove guard and drive belt from vehicle.

Remove pulley retaining screw **no. 14** and shouldered washer **no. 12** then pull the driven pulley from the countershaft.

Take care not to lose spacer **no. 2**.

Countershaft

Should countershaft **no. 1** removal be required, refer to BRAKE then look for COUNTERSHAFT and BRAKE DISC REMOVAL.

DISASSEMBLY

Use clutch spring compressor (P/N 529 035 524).



TYPICAL

Remove circlip **no. 3** and washer **no. 4** to disassemble the outer cam and the 2 pulley halves.

NOTE: Before removing cam and spring, note position of spring in fixed half (position A,B or C) and the position in the cam (1 to 6). These positions will help during assembly.

⚠ WARNING

Driven pulley cam is spring loaded, use above mentioned tool.

CLEANING

Large Bushing and Small Bushing

During break-in period (about 10 hours of use), teflon from bushing **no. 8** and **no. 9** moves to cam or shaft surface. A teflon over teflon running condition occurs, leading to low friction. So it is normal to see gray teflon deposit on cam or shaft. Do not remove that deposit, it is not dust.

When a dust deposit has to be removed from the cam or the shaft, use dry cloth to avoid removing transferred teflon.

Pulley Half Cleaning

Use pulley flange cleaner (P/N 413 711 809) to clean pulley halves.

INSPECTION

Bushings

Check the bushings **no. 8** and **no. 9** for cracks, scratch and for free movement when assembled to fixed half.

Using a dial bore gauge measure bushing diameter. Measuring point must be at least 5 mm (1/4 in) from bushing edge.



Replace bushing(s) if worn more than specified.

Section 08 DRIVE SYSTEM

Subsection 03 (DRIVEN PULLEY)

DRIVEN PULLEY BUSHING WEAR LIMIT mm (in)	
Small bushing	38.30 (1.508)
Large bushing	108.2 (4.260)

Slider Shoe

Black slider shoe = forward.

Red slider shoe = reverse.

Check cam slider shoes **no. 10** and **no. 11** for wear. Replace when inside edge thickness of cam slider shoe slope base is worn to 1 mm (.039 in) or less.

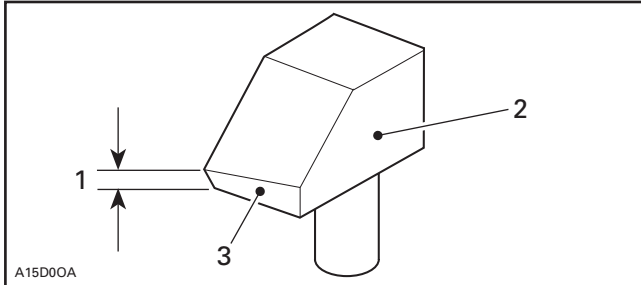

1. Measure thickness of slope base here
2. Sliding pulley side
3. Slope base

BUSHING REPLACEMENT

Large Bushing

Remove Allen screws if applicable. Heat to break Loctite bond.

Install the support plate included in the large bushing extractor (P/N 529 031 100) inside sliding half.

Place the large bushing extractor (P/N 529 035 575) below bushing.

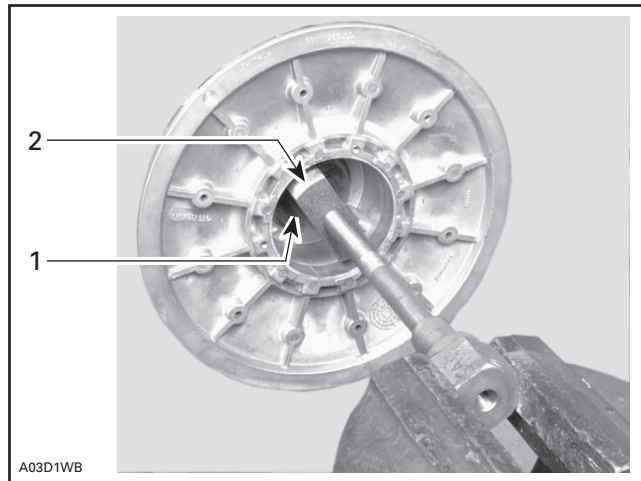

- TYPICAL
1. Support plate
 2. Extractor

Mount screw head of the clutch spring compressor (P/N 529 035 524) in a vise.

Turn pulley half by hand to extract old bushing.

Before bushing installation, file sliding half bore to remove burrs from crimping areas.

Coat bushing outside diameter with Loctite 609 (P/N 413 703 100). Place new bushing on sliding half and slightly tap to engage squarely the bushing in the sliding.

ASSEMBLY

Cam Slider Shoe

When replacing slider shoes **no. 10** and **no. 11**, always install a new set (3 shoes) to maintain equal pressure on the cam.

Install slider shoes as per following photo. Red slider shoes are being used for reverse and black ones for forward.

Section 08 DRIVE SYSTEM

Subsection 03 (DRIVEN PULLEY)

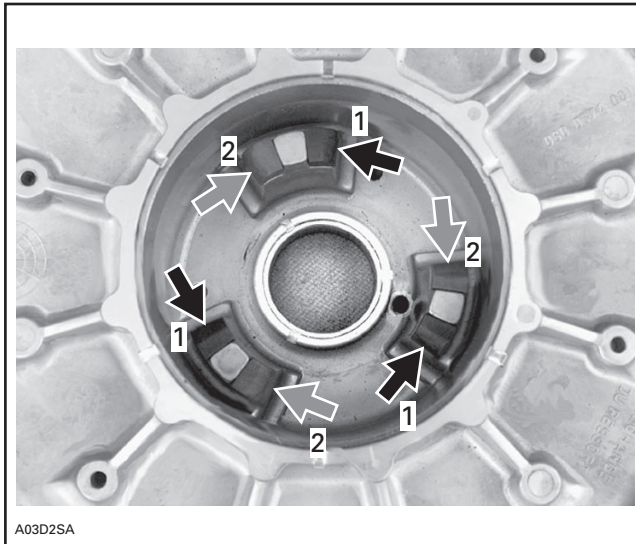

- 1. BLACK slider shoe
- 2. RED slider shoe

Assemble driven pulley components by reversing the disassembly procedure.

Cam and Spring

Make sure to install proper cam. Refer to TECHNICAL DATA.

Cam angle is identified on cam.

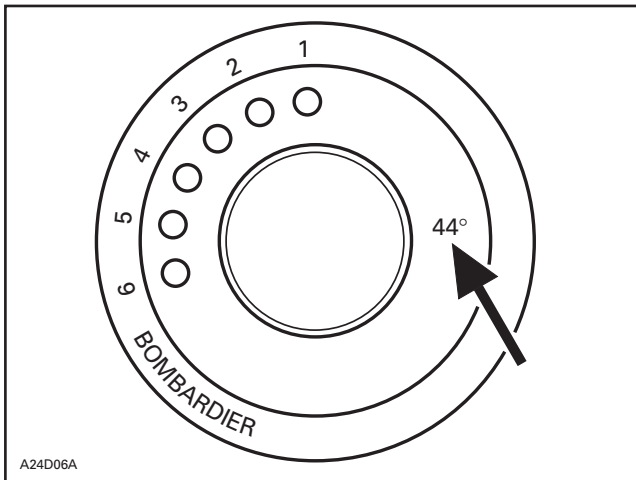

Install spring no. 6 in sliding half with its end inserted in hole B.

Position cam no. 5 then insert spring in adjusting hole no. 2 into outer cam.

IMPORTANT: With the spring ends at positions B and 2, spring preload is equal to zero (0). To work properly, the driven pulley must have a zero preload.

Compress outer cam using the clutch spring compressor (P/N 529 035 524). Install washer no. 4 then secure outer cam with circlip no. 3.

CAUTION: Ensure that circlip is properly inserted into shaft groove and that spacer recess is facing circlip.

INSTALLATION

Countershaft

Apply Loctite antiseize lubricant (P/N 293 800 070) on countershaft splines.

CAUTION: Always apply antiseize on the countershaft before final pulley installation to prevent a possible seizing up between pulley and countershaft.

Make sure that spacer no. 2 is on countershaft no. 1 before installing driven pulley. Note also that washer shoulder is facing driven pulley.

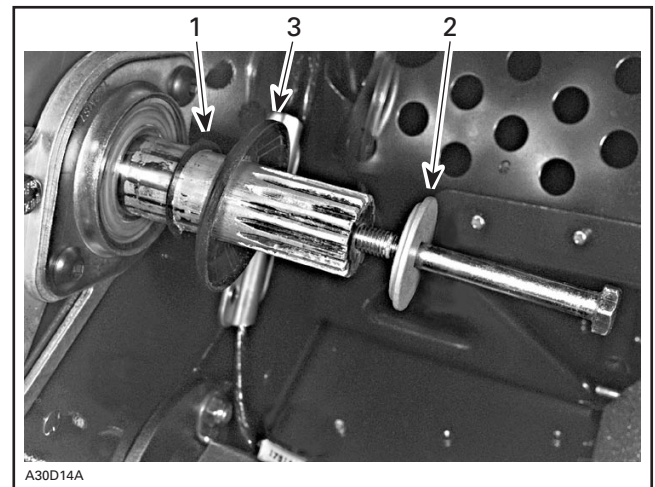

- TYPICAL**
- 1. Spacer
 - 2. Shoulder on this side
 - 3. Concave side facing driven pulley

Should installation procedure be required, refer to BRAKE then look for BRAKE DISC and COUNTER-SHAFT BEARING ADJUSTMENT.

Reinstall the pulley on the countershaft by reversing the removal procedure.

Pulley Retaining Screw

Torque pulley retaining screw no. 14 to 25 N•m (18 lbf•ft).

Section 08 DRIVE SYSTEM
Subsection 03 (DRIVEN PULLEY)

ADJUSTMENT

Cam

Make sure to install proper cam. Refer to TECHNICAL DATA.

Cam angle is identified on cam.

Spring

To check spring preload adjustment, use the spring scale hook (P/N 529 006 500) and a spring scale.

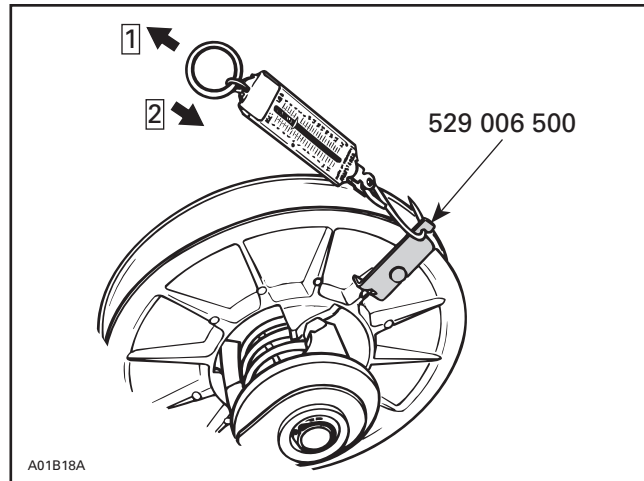
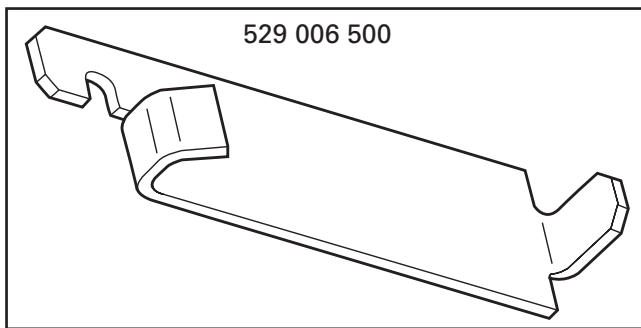

TYPICAL

1. Pull for the first measurement
2. Release slowly for the second measurement

To adjust spring preload, relocate spring end in cam, moving it clockwise to increase the preload and counterclockwise to decrease it. Refer to TECHNICAL DATA.

NOTE: If the spring preload can not be adjusted, try to relocate the other end of spring in sliding pulley (holes A, B or C).

Remove drive belt.

Install the hook on the sliding half. Preventing fixed half from turning, pull sliding half with the spring scale perpendicularly with pulley axle.

Take first measurement when sliding half begins to turn. Rotate sliding half to 10 mm (3/8 in) of rotation. Hold spring scale at this position. Slowly release tension from spring scale and take second measurement when sliding half begins to return. Spring preload is the average measurement between these 2.

$$\frac{\text{First measurement (when opening)} + \text{Second measurement (when closing)}}{2} = \text{Spring preload}$$

EXAMPLE:

$$\frac{3.8 \text{ kg (8.4 lb)} + 3.4 \text{ kg (7.5 lb)}}{2} = 3.6 \text{ kg (8 lb)} \text{ actual spring preload}$$

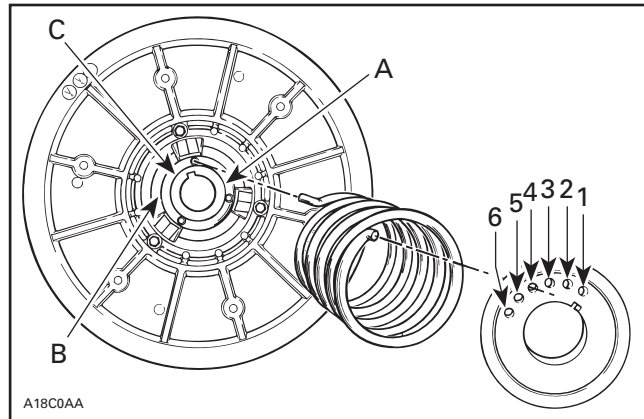

LETTERS AND NUMBERS SHOWN IN ILLUSTRATION ARE ACTUAL LETTERS AND NUMBERS EMBOSSED ON PARTS

NOTE: Always recheck torsional preload after adjusting.

Pulley Alignment and Drive Belt Deflection

Refer to PULLEY ALIGNMENT and DRIVE BELT to perform adjustments.

CAUTION: Drive belt and pulley alignment must always be checked whenever pulleys have been removed, replaced or disassembled.

Section 08 DRIVE SYSTEM

Subsection 03 (DRIVEN PULLEY)

REMOVAL

Remove guard and drive belt from vehicle.

Remove cap screw **no. 1** and shouldered washer **no. 3** then pull the driven pulley from the countershaft.

Note shouldered washer position for reinstallation. Take care not to lose spacer **no. 4**.

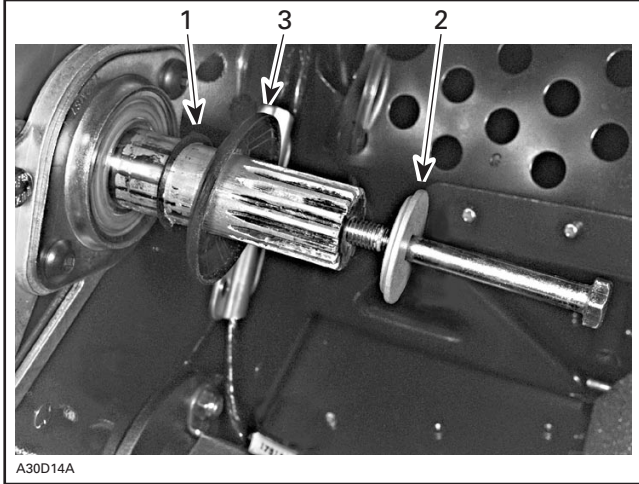

1. Spacer
2. Shoulder on this side
3. Concave side facing driven pulley

Countershaft

Should countershaft **no. 5** removal be required, refer to BRAKE then look for COUNTERSHAFT AND BRAKE DISC REMOVAL.

DISASSEMBLY

Use clutch spring compressor (P/N 529 035 524).

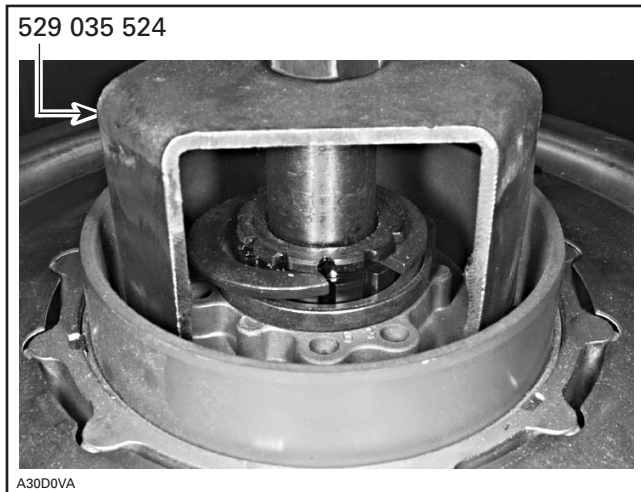

Remove half keys **no. 6** and washer **no. 7** to disassemble the cam and the 2 pulley halves.

⚠ WARNING

Driven pulley cam is spring loaded, use above mentioned tool.

CLEANING

Large Bushing and Small Bushing

During break-in period (about 10 hours of use), teflon from bushing **no. 8** and **no. 9** moves to cam or shaft surface. A teflon over teflon running condition occurs, leading to low friction. So it is normal to see gray teflon deposit on cam or shaft. Do not remove that deposit, it is not dust.

When a dust deposit has to be removed from the cam or the shaft, use dry cloth to avoid removing transferred teflon.

Pulley Half Cleaning

Use pulley flange cleaner (P/N 413 711 809) to clean pulley halves.

INSPECTION

Slider Shoe

Check cam slider shoes **no. 10** for wear. Replace when inside edge thickness of cam slider shoe slope base is worn to 1 mm (.039 in) or less.

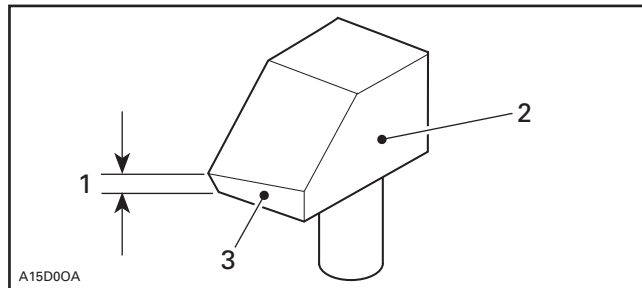

1. Measure thickness of slope base here
2. Sliding pulley side
3. Slope base

ASSEMBLY

Cam Slider Shoe

When replacing slider shoes **no. 10**, always install a new set (3 shoes) to maintain equal pressure on the cam.

Install slider shoes as per following photo. Red slider shoes are being used for reverse and black ones for forward.

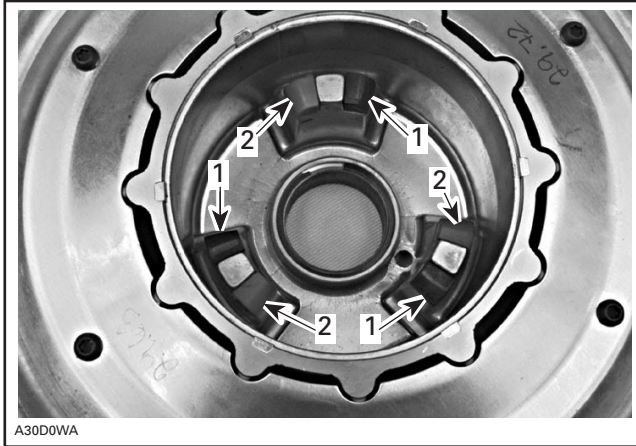

1. BLACK slider shoe
2. RED slider shoe

Screws

Screws no. 12 are machined at their end. With the adjustment ring steel to position 0 (zero), screw ends are flush with inner side of fixed pulley half when tighten.

CAUTION: If any of these screws is not flush with inner side of sliding pulley, bushings will worn unequally.

Assemble driven pulley components by reversing the disassembly procedure.

Cam

Coat cam no. 11 interior with Loctite antiseize lubricant (P/N 293 800 070).

INSTALLATION

Countershaft

Apply Loctite antiseize lubricant (P/N 293 800 070) on countershaft splines.

CAUTION: Always apply antiseize lubricant on the countershaft before final pulley installation to prevent a possible seizing up between pulley and countershaft.

Should installation procedure be required, refer to BRAKE then look for BRAKE DISC and COUNTER-SHAFT BEARING ADJUSTMENT.

Reinstall the pulley on the countershaft no. 5 by reversing the removal procedure.

ADJUSTMENT

Cam

Make sure to install proper cam no. 11. Refer to TECHNICAL DATA.

Cam angle is identified on cam.

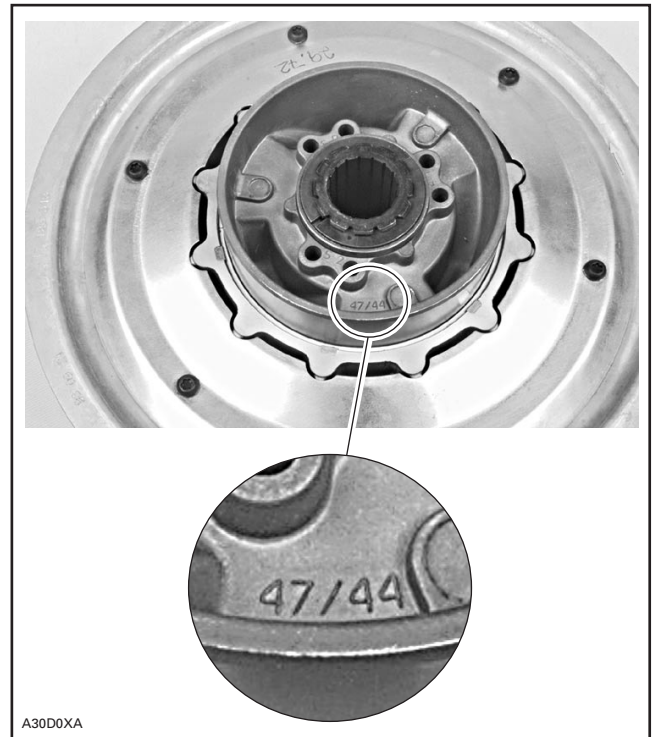

NOTE: For high altitude regions, a service bulletin will give information about calibration according to altitude.

Spring

To check spring preload adjustment, use the spring scale hook (P/N 529 006 500) and a spring scale.

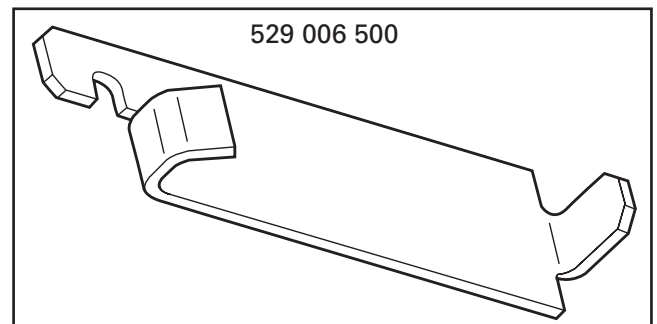

Remove drive belt.

Section 08 DRIVE SYSTEM
Subsection 03 (DRIVEN PULLEY)

Install the hook on the sliding half. Preventing fixed half from turning, pull sliding half with the spring scale perpendicularly with pulley axle.

Take first measurement when sliding half begins to turn. Rotate sliding half to 10 mm (3/8 in) of rotation. Hold spring scale at this position. Slowly release tension from spring scale and take second measurement when sliding half begins to return. Spring preload is the average measurement between these 2.

$$\frac{\text{First measurement (when opening)} + \text{Second measurement (when closing)}}{2} = \text{Spring preload}$$

EXAMPLE:

$$\frac{3.8 \text{ kg (8.4 lb)} + 3.4 \text{ kg (7.5 lb)}}{2} = 3.6 \text{ kg (8 lb)} \text{ actual spring preload}$$

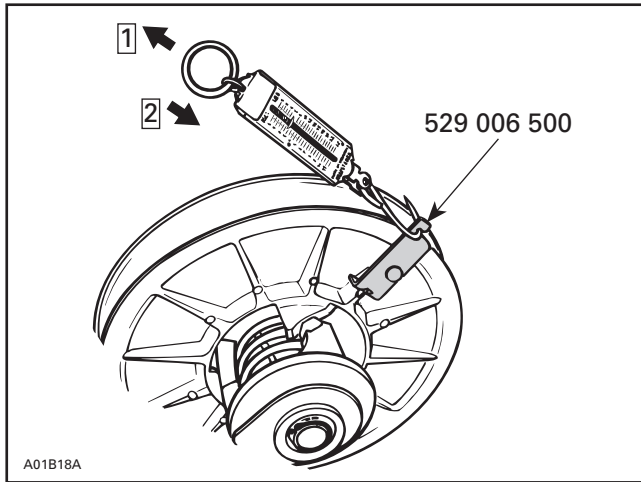

TYPICAL

1. Pull for the first measurement
2. Release slowly for the second measurement

To adjust spring preload, relocated spring end in cam, moving it clockwise to increase the preload and counterclockwise to decrease it. Refer to TECHNICAL DATA.

NOTE: If the spring preload can not be adjusted, try to relocate the other end of spring in sliding pulley (holes A, B or C).

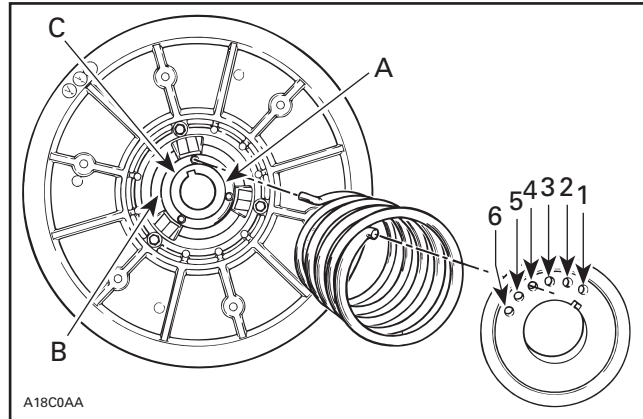

LETTERS AND NUMBERS SHOWN IN ILLUSTRATION ARE ACTUAL LETTERS AND NUMBERS EMBOSSED ON PARTS

NOTE: Always recheck torsional preload after adjusting.

Pulley Alignment and Drive Belt Height

Refer to PULLEY DISTANCE AND ALIGNMENT and DRIVE BELT to perform adjustments.

CAUTION: Drive belt and pulley adjustments must always be checked whenever pulleys have been removed, replaced or disassembled.

PULLEY ALIGNMENT

SERVICE TOOLS

Description	Part Number	Page
alignment bar.....	529 035 831	350
driven pulley opening tool.....	529 017 200	349

GENERAL

Pulley alignment must be checked out to ensure the highest efficiency of the transmission system. Furthermore, optimum drive belt operation and minimal wear will be obtained only with proper pulley alignment.

CAUTION: Before checking pulley adjustment, the rear suspension must be mounted on the vehicle and track tension/alignment must be done. Always check pulley adjustment after suspension is adjusted.

⚠ WARNING

Failure to correctly perform pulley alignment may cause the vehicle to creep forward at idle.

All Pulley Alignment Specifications Refer to:

X = Distance between straight bar and drive pulley fixed half edge, measured between pulleys.

Y = Distance between straight bar and drive pulley fixed half edge, measured at the end of straight bar.

MEASURING PROCEDURE

Remove guard, drive belt and air silencer.
Loosen lock nut.

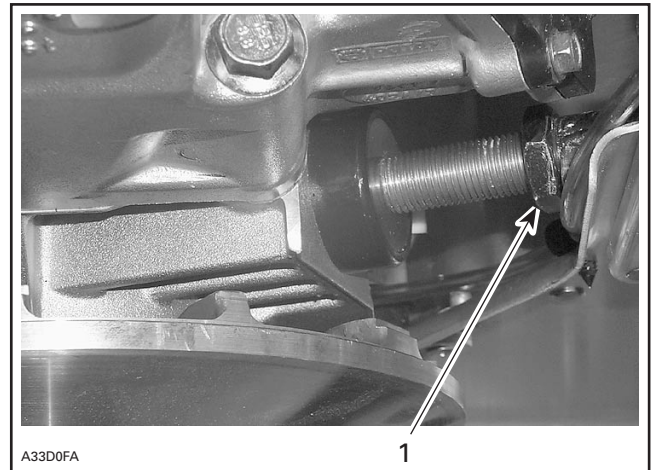

1. Lock nut

Untighten torque rod using a long hexagonal key.

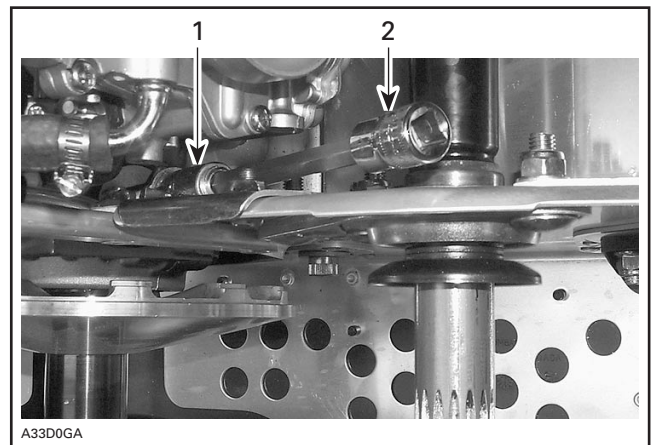

TYPICAL

1. Torque rod
2. Hexagonal key

By using driven pulley opening tool (P/N 529 017 200) push the sliding half to open the driven pulley.

Section 08 DRIVE SYSTEM
Subsection 04 (PULLEY ALIGNMENT)

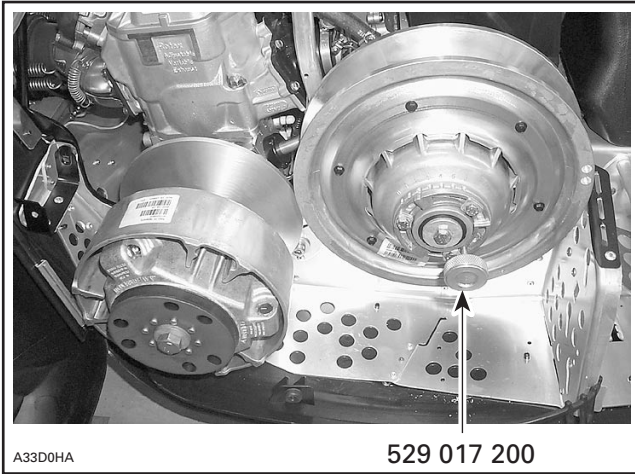

DRIVEN PULLEY OPENING TOOL

Measure the distance between both pulleys to know if the engine and the frame are positioned correctly. The distance pulley is not adjustable on the REV series vehicles.

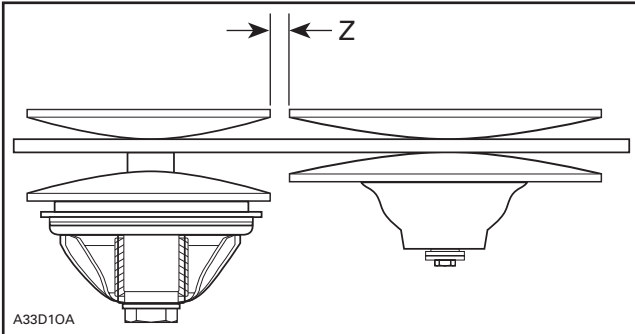

TYPICAL
Z = Distance between both pulleys

PULLEY DISTANCE	
MODEL	DISTANCE
Formula RER	17.5 mm (.689 in)
Formula VSA and VSA RER	19 mm (.748 in)
HPV VSA	20 mm (.787 in)

Insert the alignment bar (P/N 529 035 831) into the opened driven pulley.



ALIGNMENT BAR IN PULLEYS

Always measure distances X and Y from the farther straight bar side (including its thickness to the fixed half edge).

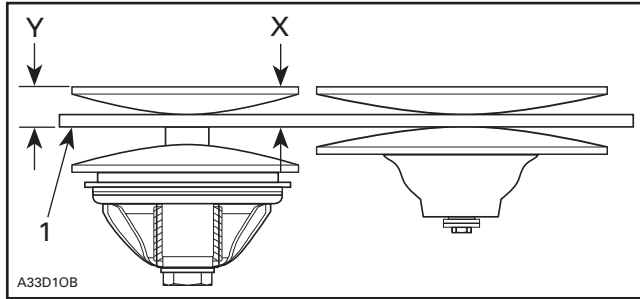

TYPICAL
 1. Straight bar

The distance Y must exceed distance X to compensate for the twist due to the engine torque.

DRIVE PULLEYS ALIGNMENT		
MODEL	OFFSET mm (in)	
	X	Y-X
	± 0.50 (.020)	
Formula RER	33.4 (1.315)	0.46 (.018) maximum
Formula VSA or Formula VSA RER	37.0 (1.456)	0.82 (0.032) maximum
HPV VSA	37.0 (1.456)	0.82 (0.032) maximum

If an alignment is necessary, see ALIGNMENT PROCEDURE below.

If the alignment is good, hand torque the torque rod so it slightly contacts engine crankcase. Do not over tighten, it will disalign pulleys.

When the alignment is done, refer to DRIVE BELT to adjust the drive belt deflection.

ALIGNMENT PROCEDURE

Remove driven pulley and add or remove spacer(s) as required to obtain the specified alignment.

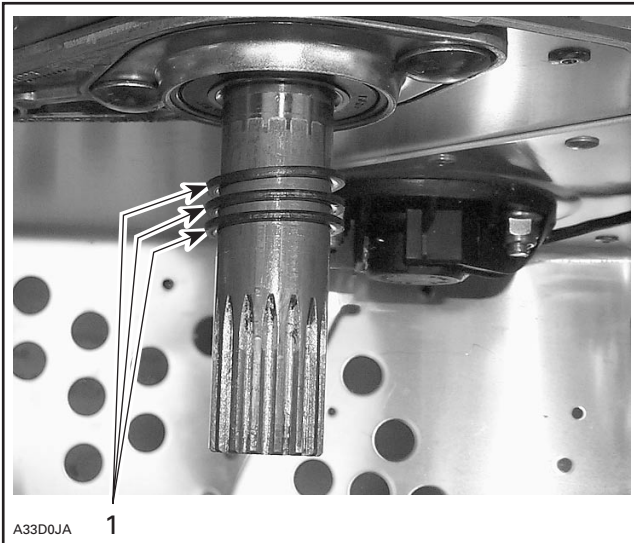

1. Spacers

Use the following table to choose the proper shim(s).

SHIM CHART	
SHIM NUMBER	SHIM THICKNESS mm (in)
504 112 000	0.42 ± 0.05 (.017 ± .002)
417 300 265	1.02 ± 0.10 (.040 ± .004)
417 300 252	2.06 ± 0.15 (.081 ± .006)

After alignment, hand tighten torque rod so it slightly contacts engine crankcase. Do not over tighten, it will disalign pulleys.

When the alignment is done, refer to DRIVE BELT to adjust the drive belt deflection.

BRAKE

SERVICE TOOLS

Description	Part Number	Page
countershaft bearing remover/installer.....	529 035 699	357-358

SERVICE PRODUCTS

Description	Part Number	Page
antiseize lubricant.....	293 800 070	357
DOT 4 brake fluid GTLMA	293 600 062	355, 359
DOT 4 brake fluid SRF	293 600 063	355, 359
Loctite 609.....	413 703 100	359

BRAKE FLUID

The brake fluid must be changed in accordance with the maintenance chart.

Use recommended DOT 4 brake fluid SRF (P/N 293 600 063) or DOT 4 brake fluid GTLMA (P/N 293 600 062).

CAUTION: Use only DOT 4 brake fluid. Do not use fluids other than the recommended one, nor mix different fluids for topping up.

MASTER CYLINDER

Removal

The master cylinder **no. 1** is located on the LH side of handlebar. To remove it, unscrew both screws **no. 2** retaining the brake lever to the handlebar.

Place a container under Banjo bolt **no. 3** then unscrew it. Discard the sealing rings **no. 4**.

Installation

The installation is the reverse of removal procedure. Pay attention to the following.

Always use new sealing rings **no. 4** during installation.

Install clamp **no. 5** with its arrow pointing at downwards. Tighten to 8 N•m (71 lbf•in) lower screw before upper one.

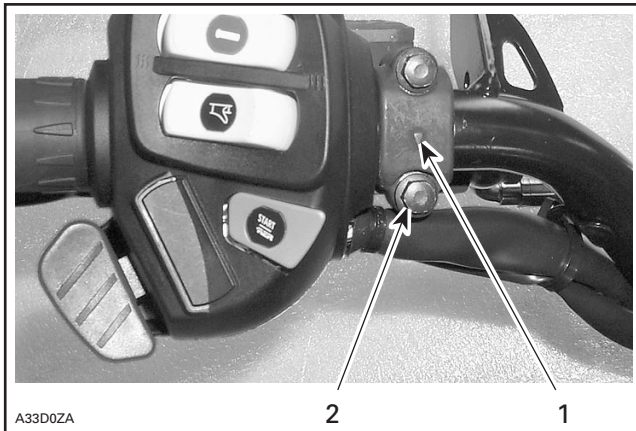

TYPICAL

1. Arrow on upper clamp pointing downwards
2. Tighten lower screw first

Bleed the brake system. Refer to BLEEDING.

CALIPER

Removal

Unscrew screws **no. 21** and remove locking tab **no. 20** to pull out caliper **no. 6** from chaincase.

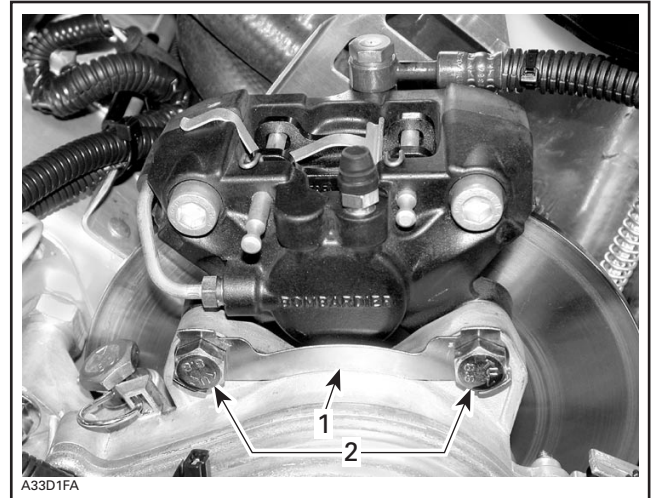

1. Locking tab
2. Screws

CAUTION: Do not let the caliper hang by the hose and do not stretch or twist the hose.

Place a container under caliper. Unscrew the bleeder screw **no. 19** and drain the brake system. Do not remove the Banjo bolt **no. 7** completely during draining.

To completely drain the brake fluid, continuous press the brake lever until all fluid escaped out.

CAUTION: Spilling brake fluid on plastic, rubber or painted parts can cause severe damage. Protect these parts by covering them with rags while servicing brake system.

When the system is empty, remove the Banjo bolt. Discard the sealing washers **no. 8**.

Inspection

Check brake pads **no. 9**, refer further in this section.

Check pistons for scratches, rust or other damages. If so, replace the caliper as an assembly.

NOTE: Only brake pads are available as spare parts.

Installation

Push pistons all the way in to allow caliper installation over brake disc.

Section 08 DRIVE SYSTEM

Subsection 05 (BRAKE)

Install the Banjo bolt no. 7 with two new sealing rings no. 8.

Fasten caliper on chaincase. Do not forget to install and fold locking tab over caliper bolt.

Fill the brake system and bleed it. Refer to BLEEDING at the end of this section.

The brake disc no. 10 must be centered in caliper. Apply brake then check for proper brake disc positioning.

Push on appropriate caliper piston in order to move pad inward allowing proper brake disc positioning.

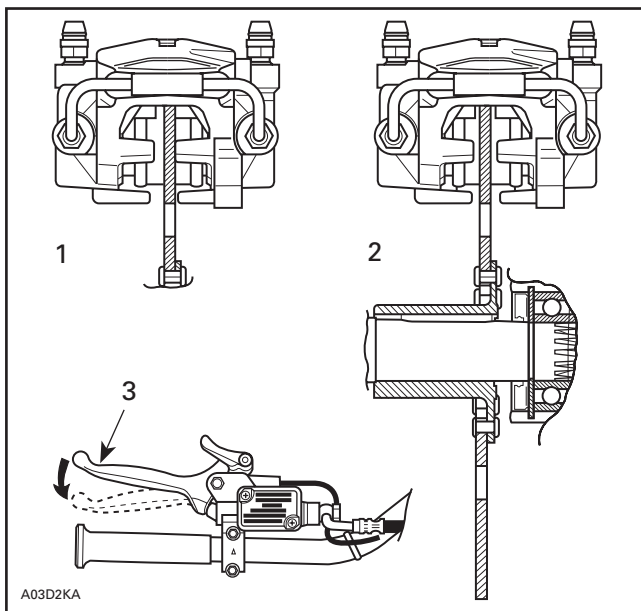

TYPICAL

1. Brake disc not centered
2. Brake disc centered
3. Apply brake before checking

Apply brake then recheck.

BRAKE PADS

Inspection

Brake pads no. 7 must be replaced when lining is 1 mm (1/32 in) thick or less or if the hollow place, on lining pad, is not visible.

CAUTION: Brake pads must always be replaced in pairs.

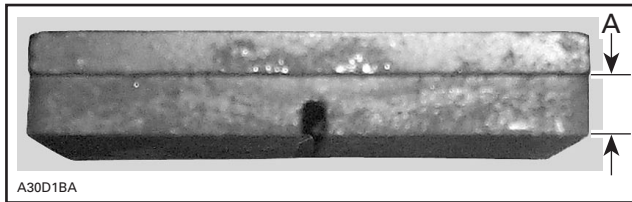

A. 1 mm (1/32 in) minimum

Removal

Brake pads removal procedure is as follows:

- Remove 2 retainers no. 12 from the pins no. 13.
- Pull out the pins which releases the spring no. 14.

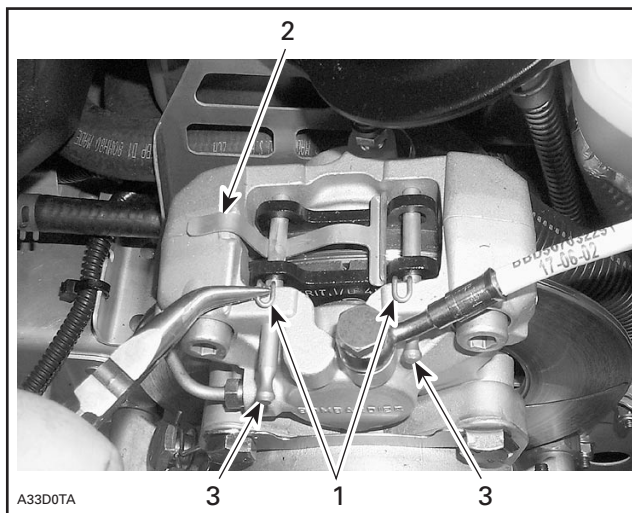

TYPICAL

1. Retainer
2. Spring
3. Pins

- Remove the brake pads no. 9.

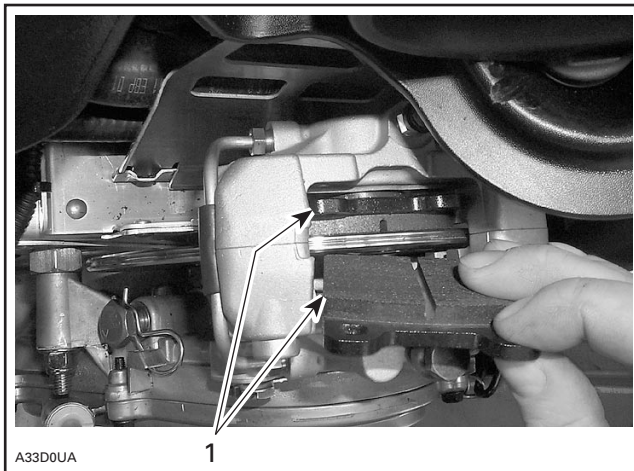
**TYPICAL**

1. Brake pad

Installation

Install:

- new brake pads
- spring and push 2 pins to lock the brake pads
- 2 retainers in the pin holes.

⚠ WARNING

Avoid getting fluid, oil or grease on brake pads. Contaminated brake pads can affect stopping capacities.

Press the brake lever until both new pads are touching the brake disc.

Center the brake disc into the caliper. Refer to CALIPER.

BRAKE DISC**Inspection**

The brake disc **no. 10** can be inspected without removing it from the vehicle.

Check for scoring, cracking or bending, replace as required.

CAUTION: Brake disc should never be machined.

Removal

Brake disc **no. 10** can be removed without removing chaincase. Proceed as follows:

- Remove belt guard, belt and driven pulley.
- Remove air silencer.

- Unbolt bearing support **no. 15** from chassis.

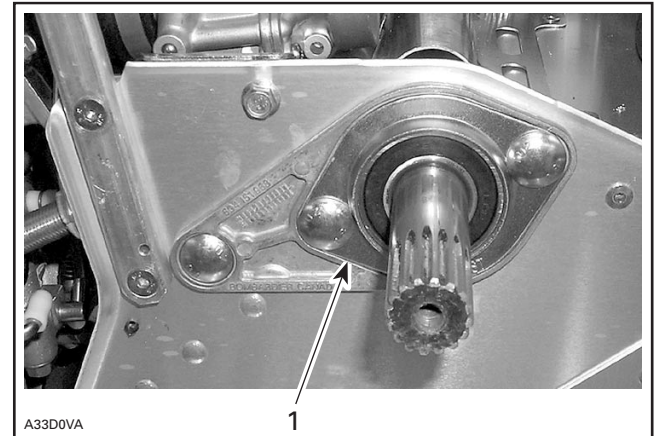

1. Bearing support

- Unscrew caliper from chaincase.
- Open chaincase and remove upper sprocket.
- Pull countershaft **no. 16** toward driven pulley side to free from chaincase and disc.
- Remove disc.

Installation

Apply antiseize lubricant (P/N 293 800 070) on shaft.

The disc hub exceeds the disc more from one side than from the other. Install disc with the longer exceeding portion toward driven pulley.

Reinstall all removed parts.

COUNTERSHAFT BEARING**Removal**

Unbolt bearing support **no. 15**. Install the countershaft bearing remover/installer (P/N 529 035 699).

Section 08 DRIVE SYSTEM

Subsection 05 (BRAKE)



1. Screws replacing bearing support screws

Tighten the countershaft bearing remover/installer bolt to pull the bearing out of its housing.

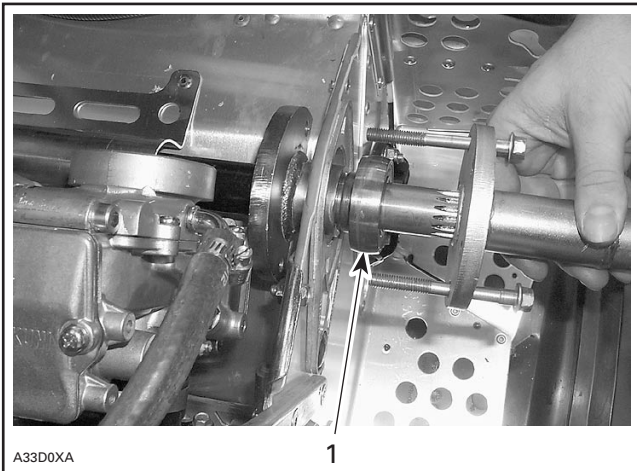

TYPICAL
1. Bearing

Installation

Insert countershaft (with brake disc) from chaincase side through countershaft support (driven pulley side), then insert into chaincase.

Install countershaft bearing **no. 17** using proper tool.

To install bearing on countershaft, use the countershaft bearing remover/installer (P/N 529 035 699) and some flat washers of 3 mm (1/8 in) total thickness. Using original retaining screw and shouldered washer tighten until bearing rests against circlip.

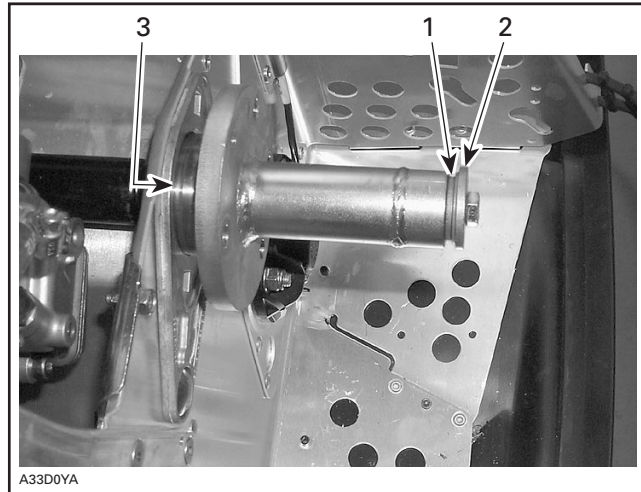

1. Washers use as a 3 mm (1/8 in) spacer
2. Original retaining screw and shouldered washer
3. Bearing against circlip

Ensure that countershaft is properly aligned, then tighten 3 retaining screws.

NOTE: A misaligned countershaft will result in difficulty to center the bearing in its support.

Torque castellated nut of upper sprocket to 60 N•m (44 lbf•ft).

Close chaincase referring to CHAINCASE.

COUNTERSHAFT

Removal

Proceed the same as for countershaft bearing removal and then remove the countershaft **no. 16**.

Inspection

Check countershaft for bending, rust or other damages. Replace if necessary.

Installation

The installation is the reverse of removal procedure.

BRAKE LIGHT SWITCH

Removal

The brake light switch **no. 18** is located near the brake lever. To remove the switch, use the following.

Disconnect the switch.

Take out the master cylinder from the handlebar.

Overturn the master cylinder so that the bottom is on the top.

Fix the master cylinder in a rigid way preferably in a vise.

Pull out the switch wire and rubber cover.

Activate the parking brake.

With the help of a proper tool, unscrew the switch body pay attention to apply a torque in axial direction with steps of little torque angles and pay attention to not apply a force in radial direction (flexion).

Remove the glue remaining with alcohol on a piece of cotton and then clean the seat threads with the clamp screw. If there is resistance to the advance of the clamp screw, use a proper wrench.

NOTE: In case of switch body breaking during the unscrewing activity, act mechanical restoring the threads on master cylinder seat and then go on with the installation procedure.

Installation

NOTE: The brake light switch is not adjustable.

Put the switch on the seat, rotating it only for 1 or 1.5 turns.

Put one drop of Loctite 609 (P/N 413 703 100) on the free switch threads.

Screw the switch by hand until it is in a correct position.

For safety reasons, check the activation of the switch by pulling the brake lever. In case of no switch activation, repeat all the procedure replacing a new switch.

NOTE: If parking brake release during the mounting operations, set the master cylinder in a sloping position (with lever on the top) and hold the master cylinder lever for 3/4 times.

Reinstall the master cylinder on the handlebar taking it in a horizontal position avoiding the risk of glue contamination for the switch rod.

Release the parking brake.

Wait 24 hours to allow glue to set.

Recheck if switch is working properly.

BLEEDING

Bleed brake system as follows:

Keep sufficient recommended DOT 4 brake fluid SRF (P/N 293 600 063) or DOT 4 brake fluid GTLMA (P/N 293 600 062) in reservoir at all times.

CAUTION: Use only DOT 4 brake fluid. Do not use fluids other than the recommended one, nor mix different fluids for topping up.

Install a clear hose on bleeder no. 19. Route this hose to a container. Open bleeder.

Pump brake lever until no air escapes from hose.

Close bleeder.

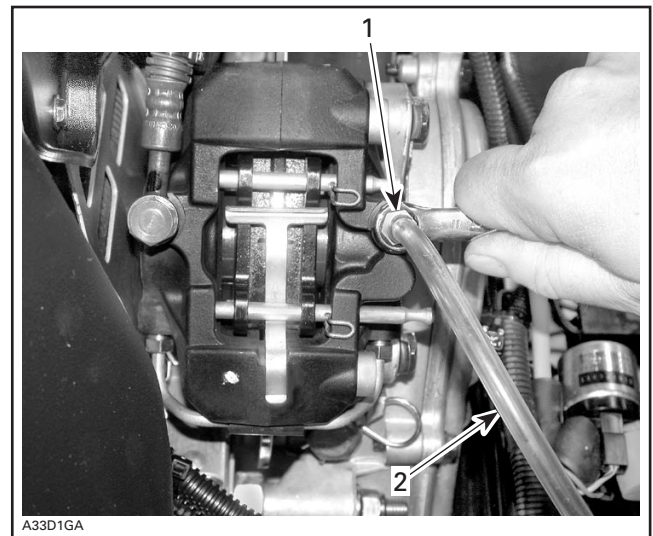

1. Open bleeder
2. Clear hose to catch used brake fluid

⚠ WARNING

Avoid getting oil on brake pads.

CHAINCASE

SERVICE TOOLS

Description	Part Number	Page
drive axle holder	529 007 200	364

SERVICE PRODUCTS

Description	Part Number	Page
Loctite 271 (red)	293 800 005	365
XP-S chaincase oil.....	413 801 900	363
XP-S synthetic chaincase oil.....	413 803 300	363

Section 08 DRIVE SYSTEM

Subsection 06 (CHAINCASE)

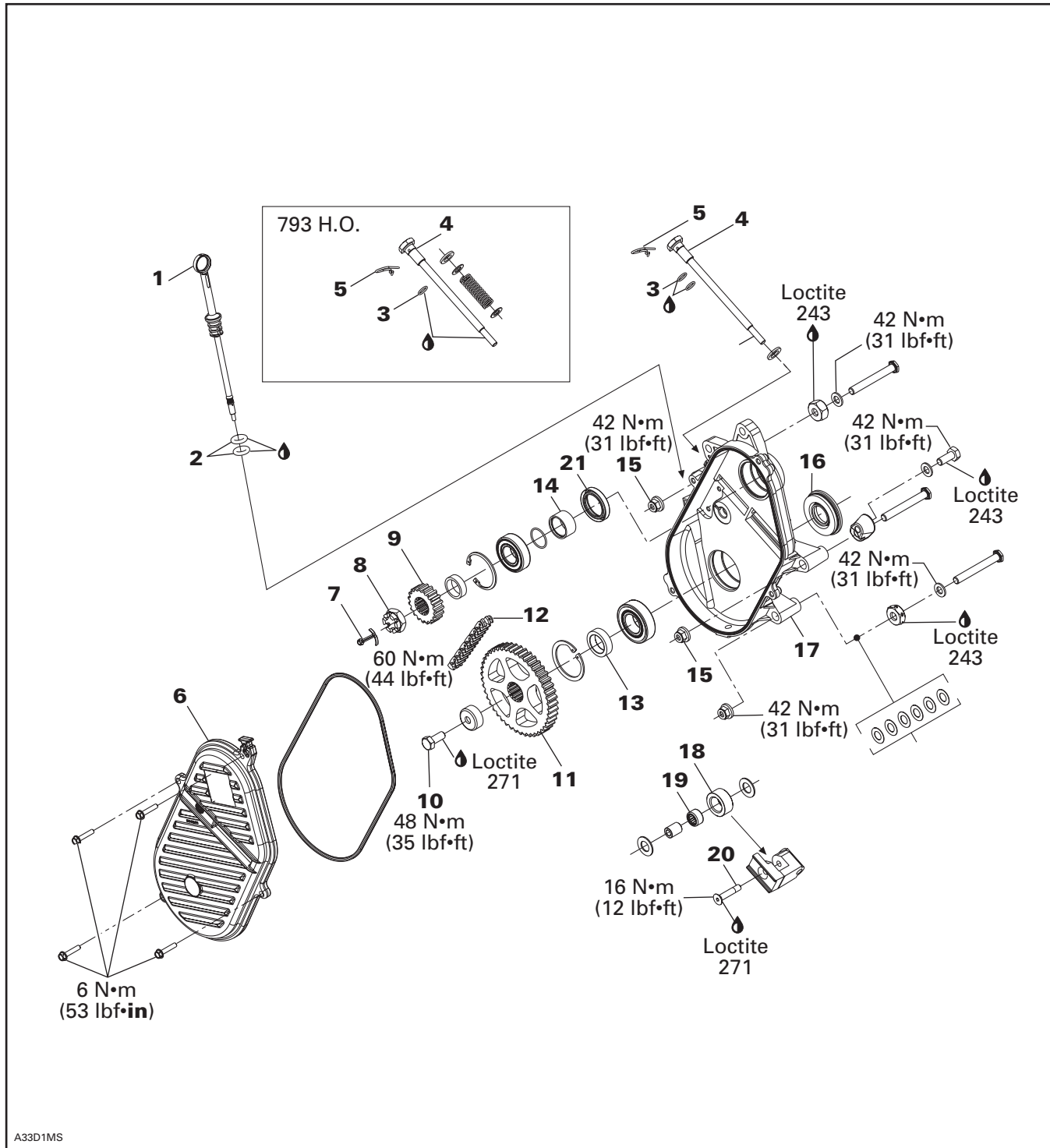

GENERAL

During assembly/installation, use the torque values and service products as in the exploded view.

Clean threads before applying a threadlocker. Refer to SELF-LOCKING FASTENERS and LOCTITE APPLICATION at the beginning of this manual for complete procedure.

WARNING

Torque wrench tightening specifications must strictly be adhered to. Locking devices (e.g.: locking tabs, elastic stop nuts, self-locking fasteners, cotter pin, etc.) must be installed or replaced with new ones where specified. If the efficiency of a locking device is impaired, it must be renewed.

CHAINCASE OIL LEVEL

With the vehicle on a level surface, check the oil level by removing dipstick no. 1. Oil level must be between lower and upper marks.

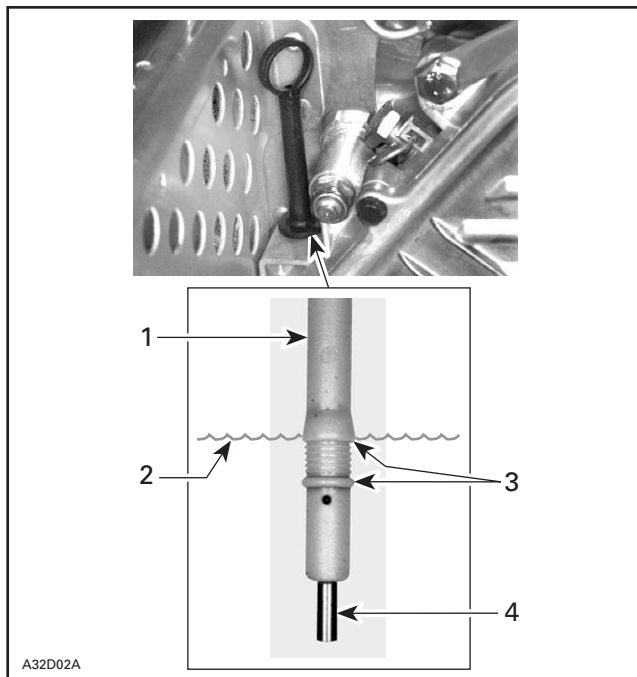

- TYPICAL**
1. Dipstick
 2. Oil level
 3. Level between marks
 4. Magnet

NOTE: It is normal to find metallic particles stuck to dipstick magnet. If bigger pieces of metal are found, remove the chaincase cover and inspect the chaincase parts.

Remove metal particles from magnet.

Refill to upper mark. See OIL CHANGE for the proper chaincase oil to use.

CAUTION: Do not use unrecommended types of oil when servicing. Do not mix synthetic oil with other types of oil.

Check O-rings no. 2. If the O-rings are brittle, hard or otherwise damaged, replace them.

OIL CHANGE

Draining Procedure

Place a drain pan under chaincase drain plug area.

Remove dipstick no. 1.

Using an Allen key, remove the drain plug.

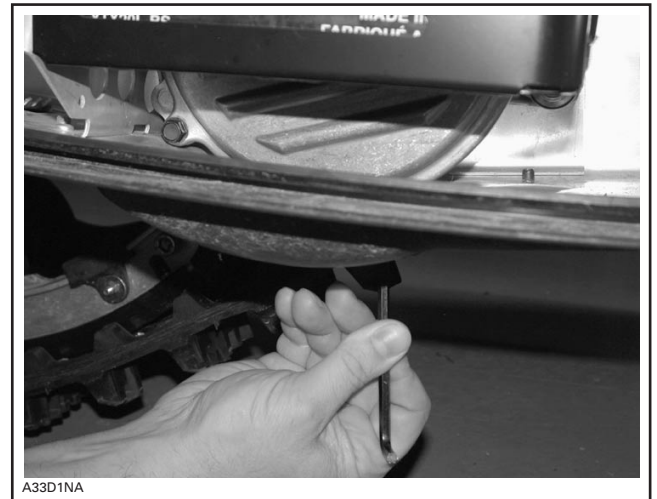

Wait a while to allow oil to flow out of chaincase.

Filling Procedure

Place the vehicle on a level surface.

Using a funnel, pour 250 mL (8.5 U.S. oz) of chaincase oil.

Fan-cooled Models

Use XP-S chaincase oil (P/N 413 801 900).

Liquid-cooled Models

Use XP-S synthetic chaincase oil (P/N 413 803 300).

Section 08 DRIVE SYSTEM

Subsection 06 (CHAINCASE)

All Models

Check oil level with the dipstick and add oil if necessary. The level must be between lower and upper dipstick's marks.

DRIVE CHAIN ADJUSTMENT

NOTE: Brake disc key must be in good condition before checking if chain is loose.

Before performing the drive chain adjustment, check the tensioner adjustment screw O-ring(s) **no. 3** and replace if necessary.

Fully tighten tensioner adjustment screw **no. 4** **BY HAND**, then back off only far enough for hair pin **no. 5** to engage in locking hole.

This initial adjustment should provide 3 - 5 mm (1/8 - 13/64 in) free-play when measured at the outer circumference of the brake disc.

CAUTION: Free-play must not exceed 5 mm (13/64 in), readjust if necessary.

WARNING

If the specified free-play is not reached with the tensioner screw fully tightened, replace chain and check the condition of sprockets.

REMOVAL AND DISASSEMBLY

To remove chaincase proceed as follows.

Remove battery and battery rack (if so equipped) to gain access, refer to BATTERY section.

Remove hair pin **no. 5**. Release drive chain tension by unscrewing tensioner adjustment screw **no. 4**.

Drain oil by removing drain plug.

Apply parking brake.

Remove chaincase cover **no. 6**.

Remove cotter pin **no. 7** and nut **no. 8** retaining upper sprocket **no. 9** and screw **no. 10** retaining lower sprocket **no. 11**. Pull sprockets and drive chain **no. 12** simultaneously. Remove shims **no. 13** and **no. 14**. Take note that shim **no. 14** is not installed on fan-cooled models.

NOTE: Should countershaft removal be required, refer to BRAKE then look for COUNTERSHAFT REMOVAL.

Release parking brake.

Remove 3 nuts **no. 15**.

Unfold locking tab then remove caliper retaining screws.

Release track tension, use the drive axle holder (P/N 529 007 200).

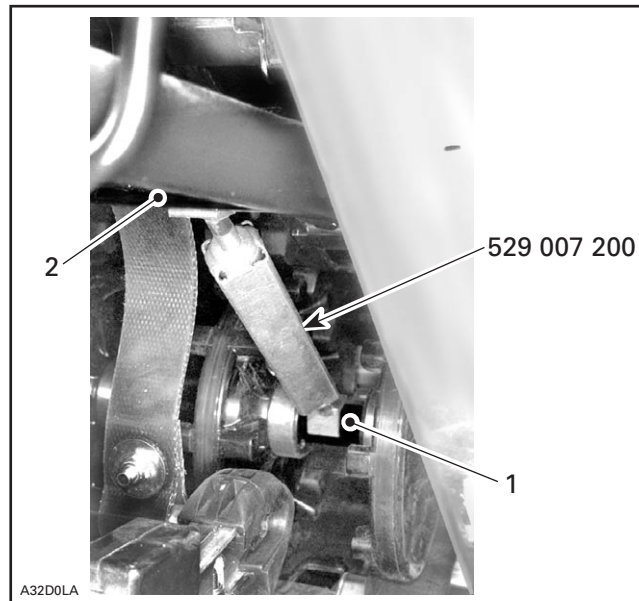
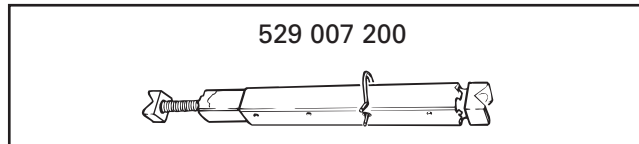

TYPICAL

1. Drive axle
2. Suspension front arm upper axle

Pry out drive axle oil seal **no. 16** from chaincase.

Pull chaincase from drive axle and countershaft.

Using 2 large prybars inserted between chaincase housing **no. 17** and frame, pry complete assembly from vehicle.

Section 08 DRIVE SYSTEM

Subsection 06 (CHAINCASE)

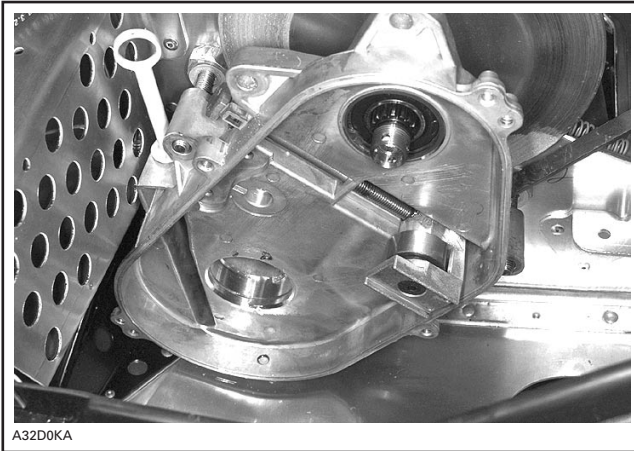

TYPICAL — CHAINCASE HOUSING REMOVAL

INSPECTION

Visually inspect the chain and sprockets for wear, cracked, damaged or missing links. If a problem is detected, replace drive chain and sprockets as an assembly.

Check the drive chain deflection. If the deflection is greater than 38 mm (1-1/2 in) without the chain tensioner, replace the chain.

Check for worn or defective bearings.

Check chain tensioner roller **no. 18** for wear or other damages. If the roller does not turn smoothly, replace the needle bearing **no. 19**.

NOTE: Heat the roller screw **no. 20** to break the threadlocker. During installation of screw, apply Loctite 271 (red) (P/N 293 800 005) under the screw's head only, no on threads.

INSTALLATION AND ASSEMBLY

Reverse removal and disassembly procedure and pay attention to the following.

Using an appropriate pusher, press the oil seal **no. 21** into chaincase hub. Oil seal must fit flush with the chaincase edge.

NOTE: Should installation procedure for counter-shaft be required, refer to BRAKE.

Install the circlip **no. 22** on drive axle.

CAUTION: It is of the utmost importance to install the circlip otherwise damage to the chaincase components may occur.

Position the sprockets **no. 9** and **no. 11** with the backside of writing facing the chaincase cover. Sprocket hub faces toward chaincase.

Install the castellated nut **no. 8** and torque to 60 N•m (44 lbf•ft).

Apply Loctite 271 (red) (P/N 293 800 005) on lower sprocket screw threads and torque to 48 N•m (35 lbf•ft).

Install new cotter pin **no. 7** in the position shown.

CAUTION: When removing a cotter pin always replace with a new one. Cotter pin will rub on chaincase cover if installed otherwise.

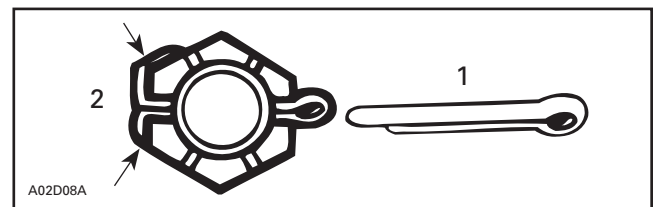

1. New
2. Fold cotter pin over castellated nut flats only

SILENT CHAIN

Do not use chain other than the 13-plates wide on REV series models. Fit chain on top sprocket to make sure that you are using right one according to width. Refer to TECHNICAL DATA.

NOTE: No work (separation, lengthening) can be done on the silent chain type.

DRIVE AXLE

SERVICE TOOLS

<u>Description</u>	<u>Part Number</u>	<u>Page</u>
drive axle sprocket adjuster kit	861 725 700	373

SERVICE PRODUCTS

<u>Description</u>	<u>Part Number</u>	<u>Page</u>
suspension synthetic grease	293 550 033	373

Section 08 DRIVE SYSTEM

Subsection 07 (DRIVE AXLE)

All Fan-cooled Models

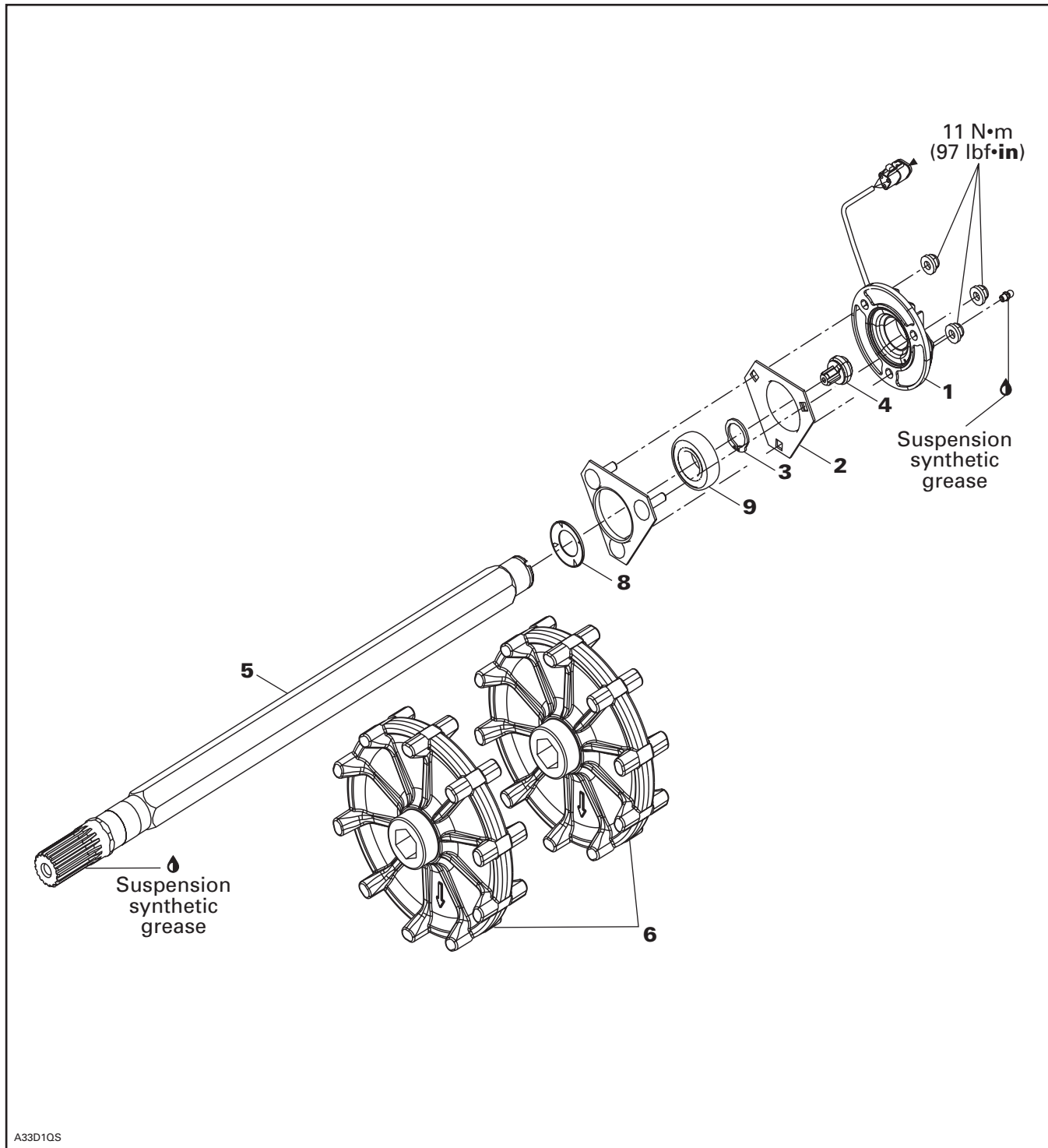

Section 08 DRIVE SYSTEM

Subsection 07 (DRIVE AXLE)

***GSX Limited and Sport, GTX Limited and Sport, MX-Z Adrenaline,
Renegade, Renegade X and Trail Models***

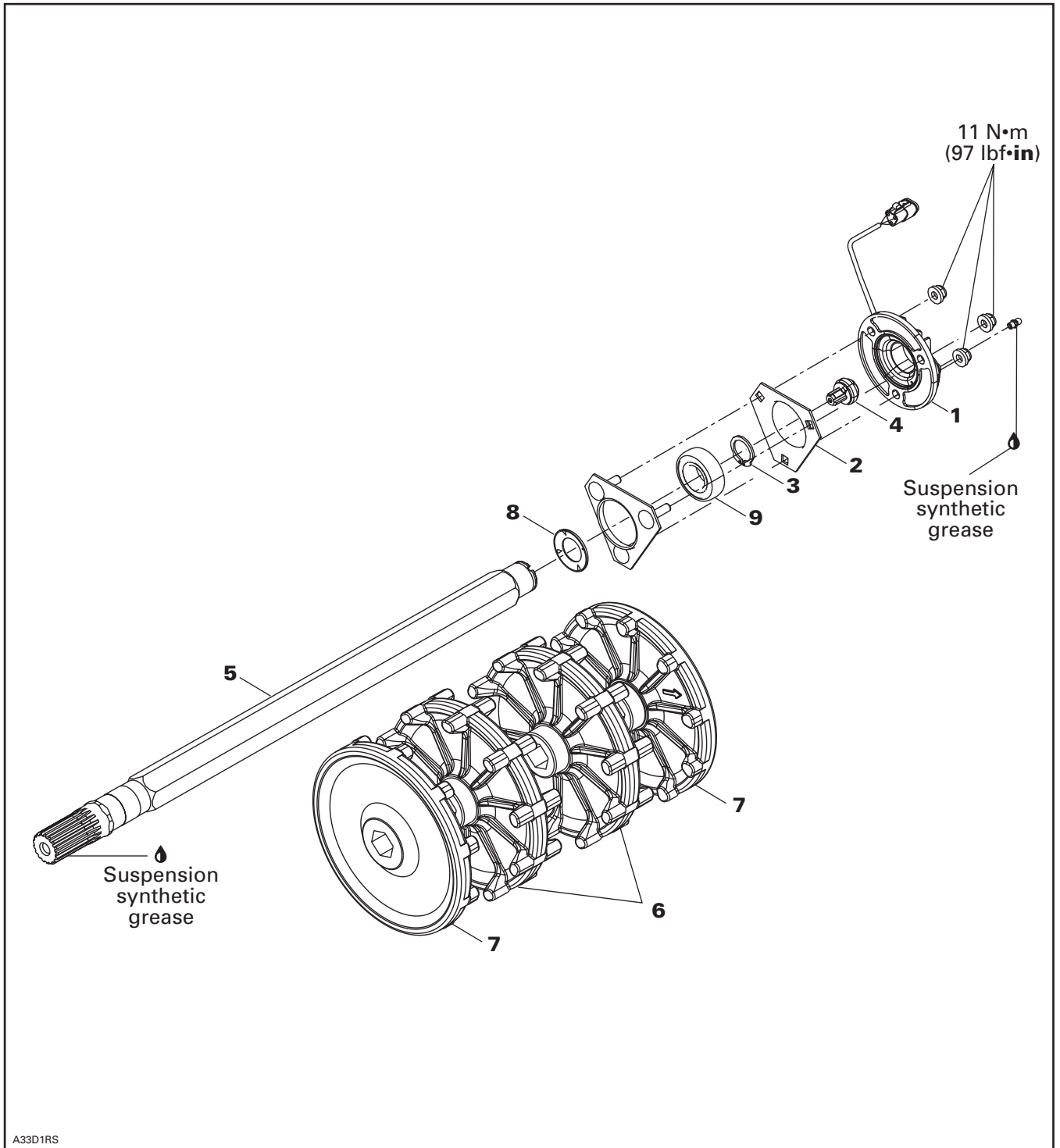

A33D1RS

Section 08 DRIVE SYSTEM

Subsection 07 (DRIVE AXLE)

MX-Z X, Summit Adrenaline and Summit X Models

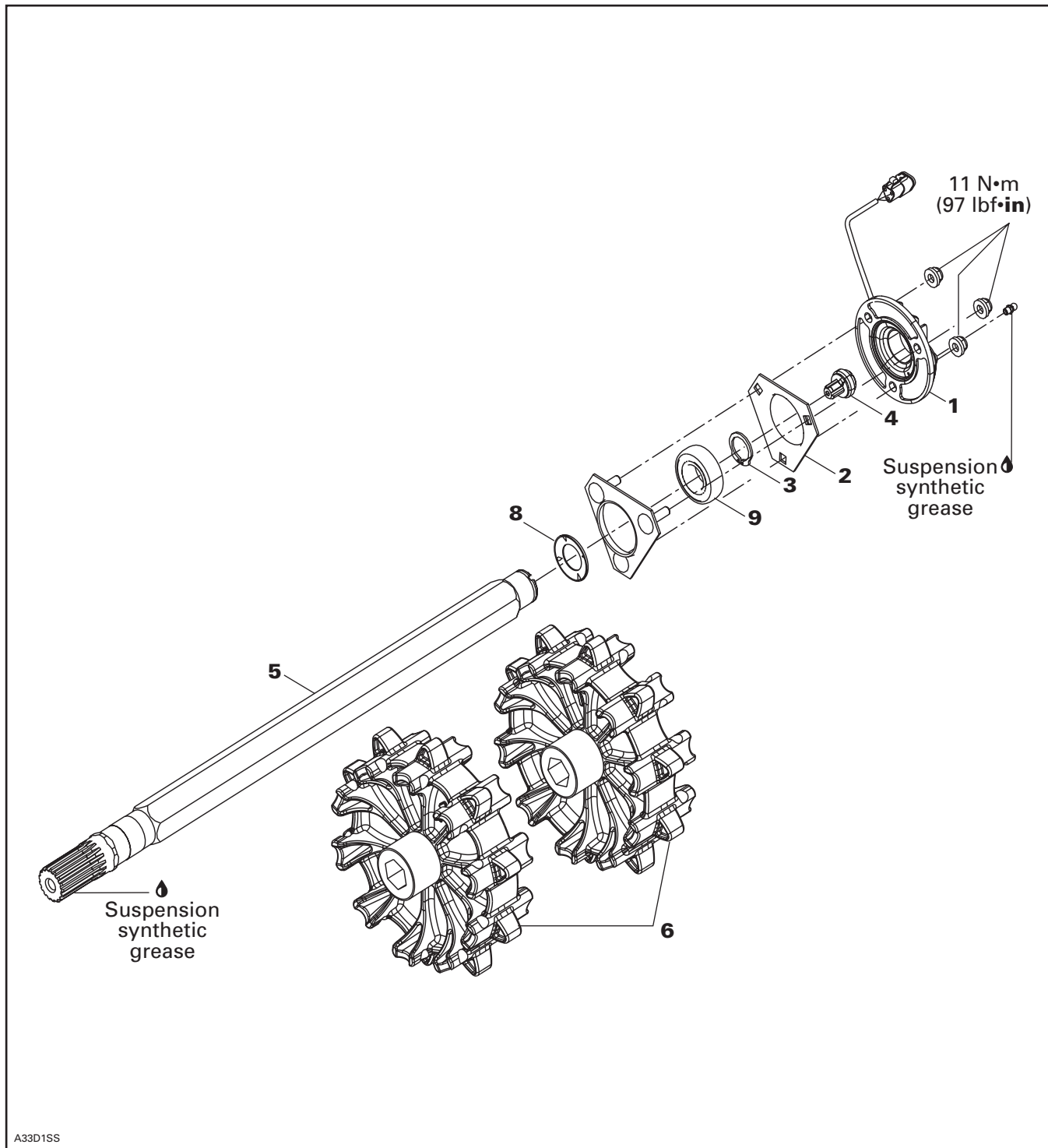

Section 08 DRIVE SYSTEM

Subsection 07 (DRIVE AXLE)

REMOVAL

Remove battery (if so equipped) to gain access, refer to CHARGING section.

Drain oil from chaincase. Remove chaincase cover. Release drive chain tension.



Raise and block rear of vehicle off the ground.

Remove suspension. Refer to proper subsection.

On some models, track can be held in tunnel using a rod in place of center idler wheel axle.

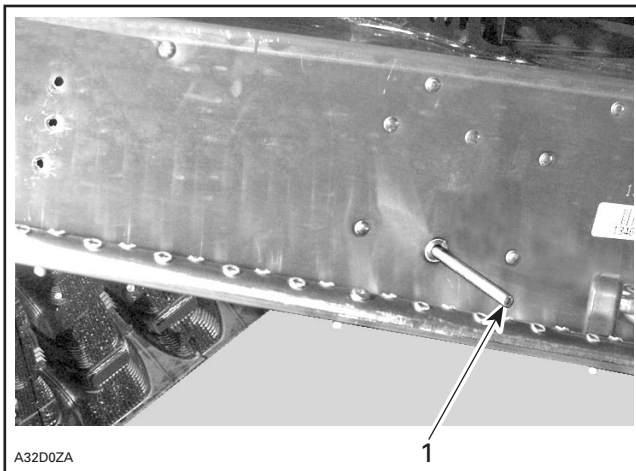

TYPICAL
1. Rod

Remove driven pulley. Refer to DRIVEN PULLEY.

Remove speedometer sensor **no. 1**, outer flange **no. 2** and circlip **no. 3** from left side.

Unscrew then pull speedometer magnetic adapter **no. 4** from drive axle **no. 5**.

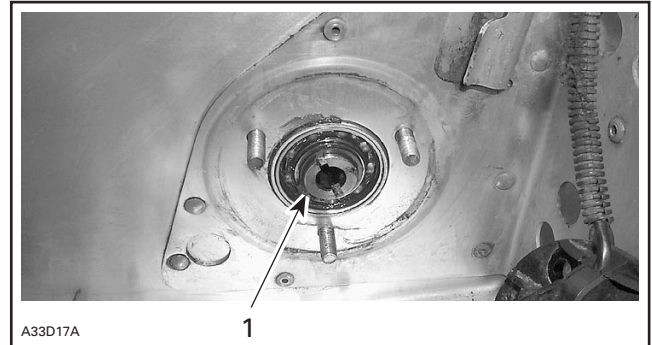

1. Circlip

Apply parking brake.

Remove chain and sprockets then circlip from right side.

Release drive axle sprocket from track and at the same time, push the drive axle **no. 5** toward the right side. Drive axle bearing in chaincase will fall off.

Sprocket and Half-Sprocket

To remove press fit sprockets **no. 6** and **no. 7**, use a press and a suitable support as illustrated.

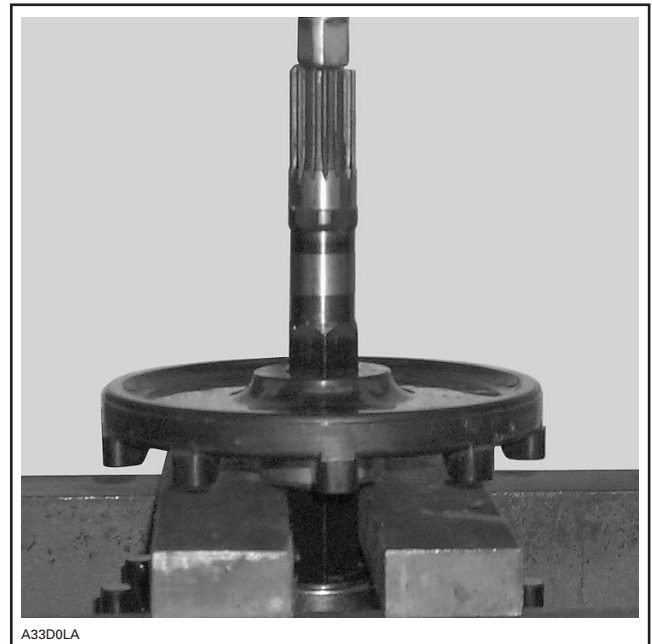

1. Support sprocket near hub

Section 08 DRIVE SYSTEM

Subsection 07 (DRIVE AXLE)

ASSEMBLY

Drive Axle and Sprocket

To assemble press fit sprockets no. 6 and no. 7, use a press and a suitable pipe as illustrated. Sprockets must be assembled according to the following dimensions measured from drive axle end.

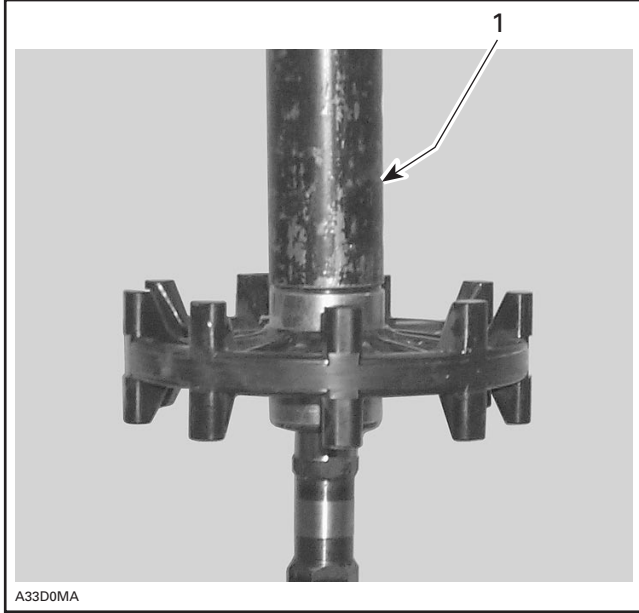

1. Pipe

All Fan-cooled Models

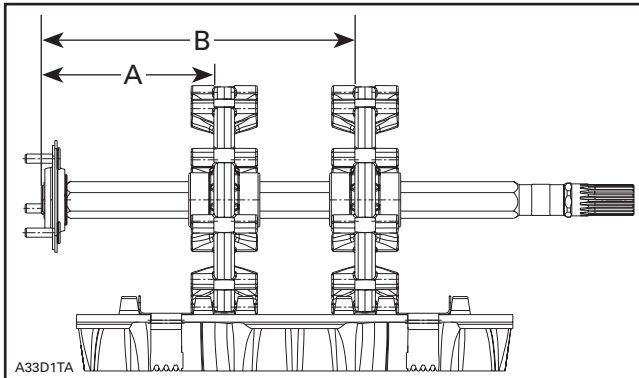

MEASURE FROM END OF DRIVE SHAFT

- A. 150.8 mm (5.937 in)
- B. 273.8 mm (10.790 in)

GSX Limited and Sport, GTX Limited and Sport, MX-Z Adrenaline, Renegade, Renegade X and Trail Models

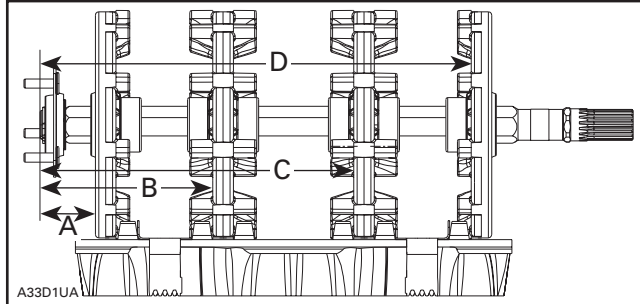

MEASURE FROM END OF DRIVE SHAFT

- A. 48.3 mm (1.902 in)
- B. 150.8 mm (5.937 in)
- C. 273.8 mm (10.780 in)
- D. 376.3 mm (14.815 in)

MX-Z X, Summit Adrenaline and Summit X Models

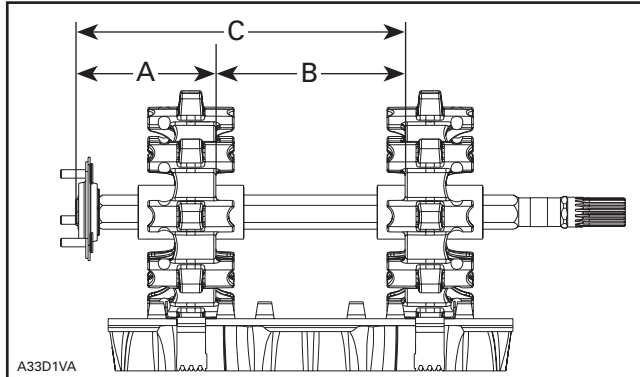

MEASURE FROM END OF DRIVE SHAFT

- A. 132.2 mm (5.205 in)
- B. 178.1 mm (7.0118 in)
- C. 310.4 mm (12.220 in)

Ensure to align indexing marks of each sprocket when assembling.

Section 08 DRIVE SYSTEM

Subsection 07 (DRIVE AXLE)

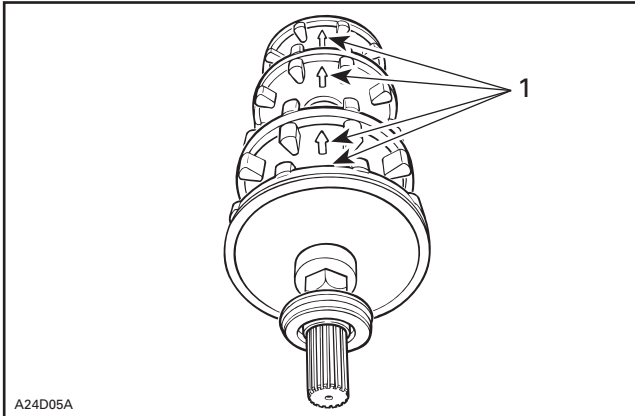

TYPICAL

1. Indexing marks aligned

CAUTION: The same sprocket must not be pressed twice on the axle. When sprocket has been removed from drive axle, use a new sprocket at the installation.

Bearing Protector

At assembly, flat side of bearing protector no. 8 must be against bearing no. 9.

Bearing

Always push bearing no. 9 by inner race.



The bearing no. 9 must have its shield facing the sprocket.

The drive axle bearing in chaincase must have its shield facing right side (cover).

Index speedometer magnetic adapter no. 4 in drive axle and push until it is completely inserted in its hole.

LUBRICATION

Lubricate end housing bearing with suspension synthetic grease (P/N 293 550 033). Continue lubricating until grease flows out of the pilot hole on speedometer sensor.

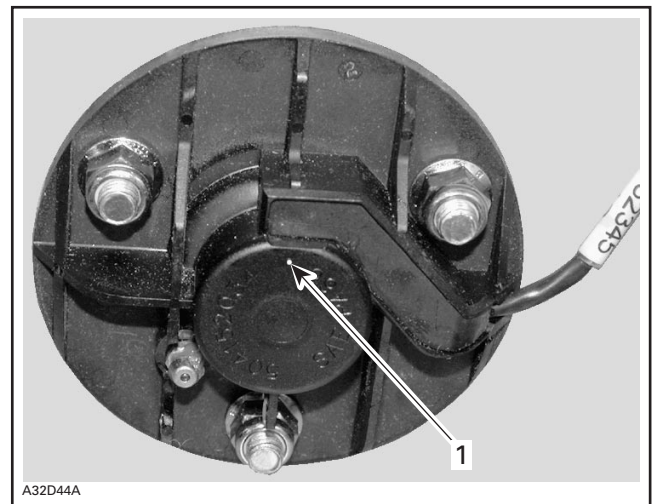

1. Lubricate until grease flows out here

ADJUSTMENT

Sprocket/Track Alignment

CAUTION: Do not tamper with sprocket/track alignment if frame or suspension is damaged.

Sprockets may be repositioned to fit lugs without removing drive axle.

Use drive axle sprocket adjuster kit (P/N 861 725 700).

Section 08 DRIVE SYSTEM

Subsection 07 (DRIVE AXLE)

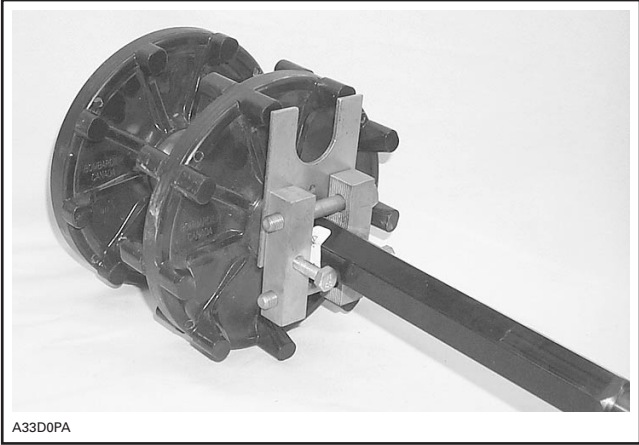

A33D0PA

TRACK

SERVICE TOOLS

Description	Part Number	Page
belt tension tester	414 348 200	376
cleat remover.....	529 028 700	375, 377
narrow-cleat installer	529 028 800	375, 377

TRACK TYPE APPLICATION

Refer to TECHNICAL DATA.

GENERAL

This section gives guidelines for track removal. Some components require more detailed disassembly procedures. In these particular cases, refer to the pertaining section in this manual.

INSPECTION

Visually inspect track for:

- cuts and abnormal wear
- broken rods
- broken or missing track cleats.

If track is damaged or rods are broken, replace track. For damaged or missing cleats, replace by new ones, using cleat remover (P/N 529 028 700). Use narrow-cleat installer (P/N 529 028 800).

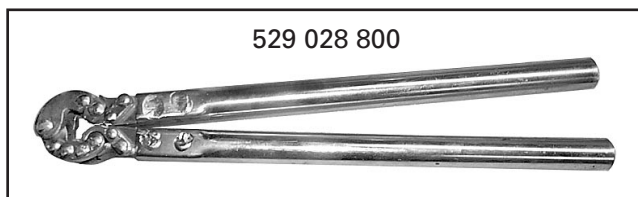
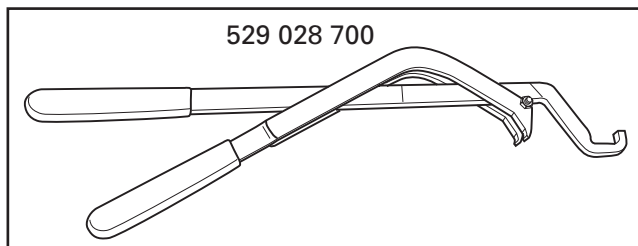

⚠ WARNING

Do not operate a snowmobile with a cut, torn or damaged track.

REMOVAL

Remove the following parts:

- rear suspension (refer to SUSPENSION)
- drive axle (refer to DRIVE AXLE)
- track.

INSTALLATION

Reverse the removal procedure.

NOTE: When installing the track, respect rotation direction indicated by an arrow on track thread.

Check sprocket/track alignment as described in DRIVE AXLE.

ADJUSTMENT

Track Tension and Alignment

Track tension and alignment are interrelated. Do not adjust one without checking the other. Track tension procedure must be carried out prior to track alignment.

Tension

NOTE: Ride the snowmobile in snow about 15 to 20 minutes prior to adjusting track tension.

Lift snowmobile by a rope, chain or lift strap hooked to rear bumper.

Section 08 DRIVE SYSTEM

Subsection 08 (TRACK)

Allow the rear suspension to fully extend and check gap halfway between front and rear idler wheels. Measure between slider shoe bottom and inside of track. The gap should be as given in SPECIFICATIONS. If the track tension is too loose, track will have a tendency to thump.

NOTE: The belt tension tester (P/N 414 348 200) may be used to measure deflection as well as force applied.

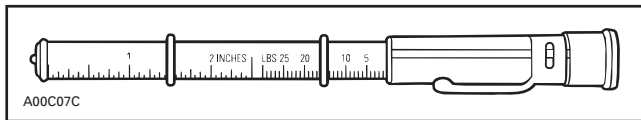

BELT TENSION TESTER

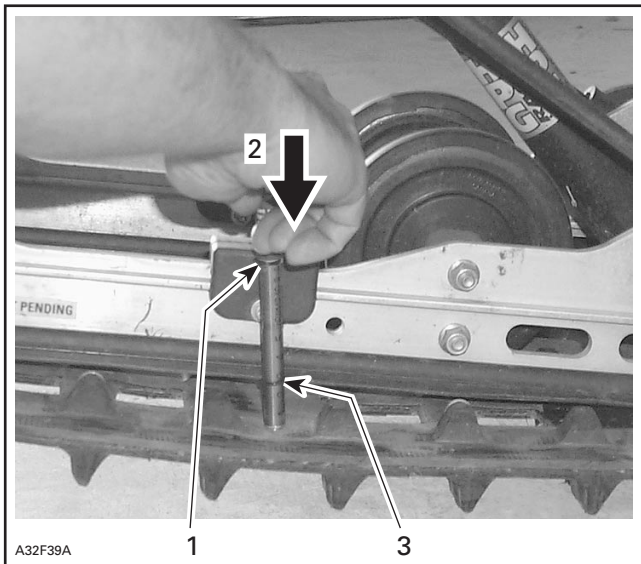

1. Top tool O-ring positioned at 7.3 kg (16 lb)
2. Push on top portion of tool until it contacts the top O-ring
3. Measured track deflection

CAUTION: Too much tension will result in power loss and excessive stresses on suspension components.

To Adjust Tension:

- Remove wheel caps.
- Loosen the rear idler wheel retaining screws.
- Turn adjustment screws to adjust.

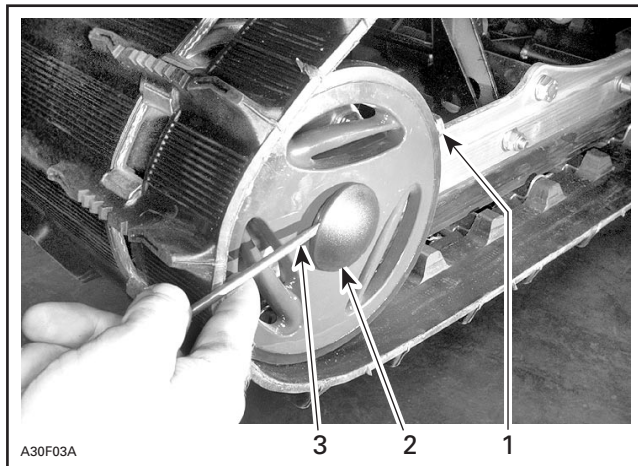

TYPICAL

1. Adjustment screw
2. Retaining screw
3. Wheel cap removal

Alignment

WARNING

Before checking track alignment, ensure that the track is free of all particles which could be thrown out while track is rotating. Keep hands, tools, feet and clothing clear of track. Ensure no one is standing in close proximity to the vehicle. Never rotate at high speed.

Start the engine and accelerate slightly so that track barely turns. This must be done in a short period of time (1 to 2 minutes).

Check that the track is well centered; equal distance on both sides between edges of track guides and slider shoes.

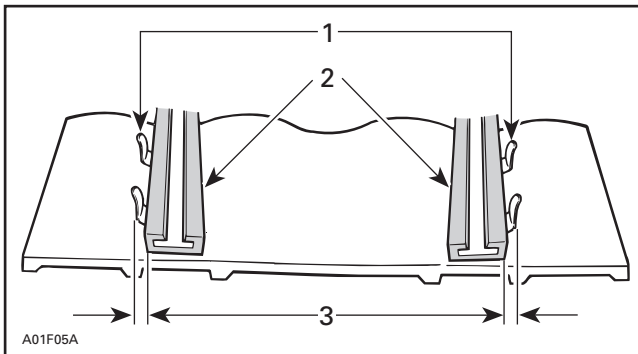

1. Guides
2. Slider shoes
3. Equal distance

To correct, stop engine, loosen rear wheel screws, then tighten the adjustment screw on side where the slider shoe is the farthest from the track insert guides.

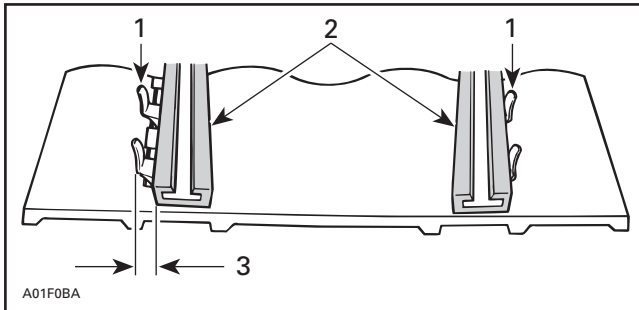

1. Guides
2. Slider shoes
3. Tighten on this side

Restart engine, rotate track slowly and recheck alignment. If the satisfactory alignment is achieved, then tighten the idler wheel retaining screws to 48 N•m (35 lbf•ft). Reinstall the wheel caps.

TRACK CLEAT

Removal

- Raise rear of vehicle off the ground and lift snow guard then hand rotate track to expose a cleat to be replaced.
- Use track cleat remover (P/N 529 028 700) for all models.

Installation

- Place new cleat in position on the track and using the narrow-cleat installer (P/N 529 028 800) bend cleat then push tabs into rubber.
- Re-open installer, then position cleat tabs on open end of tool and squeeze tabs until they are indented in rubber.

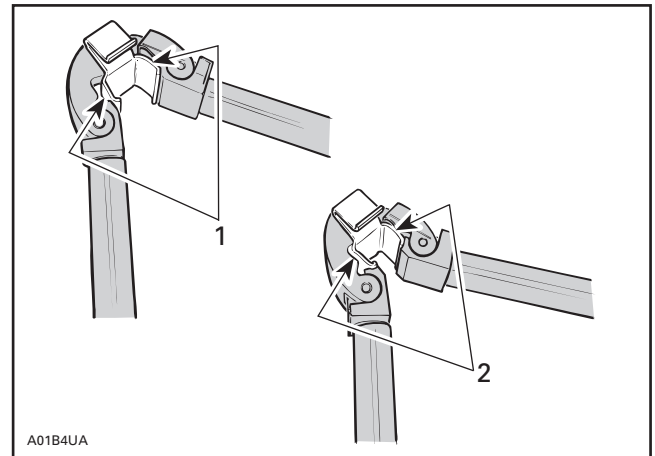

TYPICAL

1. First step
2. Second step (to push tabs into rubber)

TRACTION ENHANCING PRODUCTS (STUDS)

Important Safety Rules

⚠ WARNING

To prevent serious injury to individuals near the snowmobile:

- NEVER stand behind or near a moving track.
- ALWAYS use a wide-base snowmobile stand with a rear deflector panel.
- When the track is raised off the ground, only run it at lowest possible speed.

Centrifugal force could cause debris, damaged or loose studs, pieces of torn track, or an entire severed track to be violently thrown backwards out of the tunnel with tremendous force, possibly resulting in the loss of a leg or other serious injury.

Section 08 DRIVE SYSTEM

Subsection 08 (TRACK)

Effects of Studding on the Life of the Snowmobile

The use of traction enhancing products can increase the load and the stress on certain snowmobile components, as well as the vibration level. This can cause premature wear on parts such as belts, brake lining, bearings, chain, and chain-case sprockets, and shorten track life. For this reason, it is even more important to follow the detailed maintenance program given in the MAINTENANCE CHART.

Studs can also cause serious damage to the snowmobile if it is not equipped with the tunnel protectors designed for the particular model. Damage to the electrical wiring or perforation of the heat exchangers are potential hazards, that could cause the engine to overheat and be severely damaged.

WARNING

If tunnel protectors are excessively worn or not installed, the gas tank could be punctured, causing a fire.

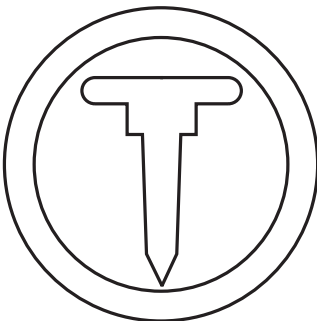

A33A35A

APPROVED TRACKS CAN BE IDENTIFIED BY THIS SYMBOL

Maintenance/Replacement

A visual inspection of the track should be performed before each use.

Look for any defects, such as:

- perforations in the track
- tears in the track (particularly around traction holes)
- lugs that are broken or torn off, exposing portion of rods
- delamination of the rubber
- broken rods
- broken studs
- bent studs

- studs that are torn off the track
- missing track guide(s).

Replace broken or damaged studs immediately. If the track shows signs of deterioration, it must be replaced immediately. In doubt, replace the track.

WARNING

Riding with a damaged track or studs could lead to loss of control, resulting in a risk of serious injury or death.

Installation

To install studs, refer to the manufacturer's instructions.

Section 08 DRIVE SYSTEM
Subsection 08 (TRACK)

TRACK		MODELS	FRONT PROTECTOR	REAR PROTECTOR	SUPPORT
Profile height	Track length				
22 mm (7/8 in) and 25.4 mm (1 in)	3.07 m (121 in)	GSX (fan-cooled)	N/A	12.9 mm (1/2 in)	Required
		MX-Z (fan-cooled)	N/A	12.9 mm (1/2 in)	Required
		GSX	N/A	20 mm (25/32 in)	—
		MX-Z	N/A	20 mm (25/32 in)	—
	3.45 m (136 in)	GTX	N/A	20 mm (25/32 in)	—
		MX-Z	N/A	20 mm (25/32 in)	—
		Summit (fan-cooled)	N/A	12.9 mm (1/2 in)	Required
31.8 mm (1.25 in)	3.07 m (121 in)	GSX (fan-cooled)	N/A	12.9 mm (1/2 in)	Required
		MX-Z (fan-cooled)	N/A	12.9 mm (1/2 in)	Required
		GSX	Standard	20 mm (25/32 in)	—
		MX-Z	Standard	20 mm (25/32 in)	—
	3.45 m (136 in)	Expedition (fan-cooled)	N/A	12.9 mm (1/2 in)	Required
		GTX	Required	20 mm (25/32 in)	—
		MX-Z	Standard	20 mm (25/32 in)	—
		Summit (fan-cooled)	N/A	12.9 mm (1/2 in)	Required

SC SUSPENSION

SERVICE PRODUCTS

<u>Description</u>	<u>Part Number</u>	<u>Page</u>
suspension synthetic grease	293 550 033	393

Section 09 REAR SUSPENSION

Subsection 01 (SC SUSPENSION)

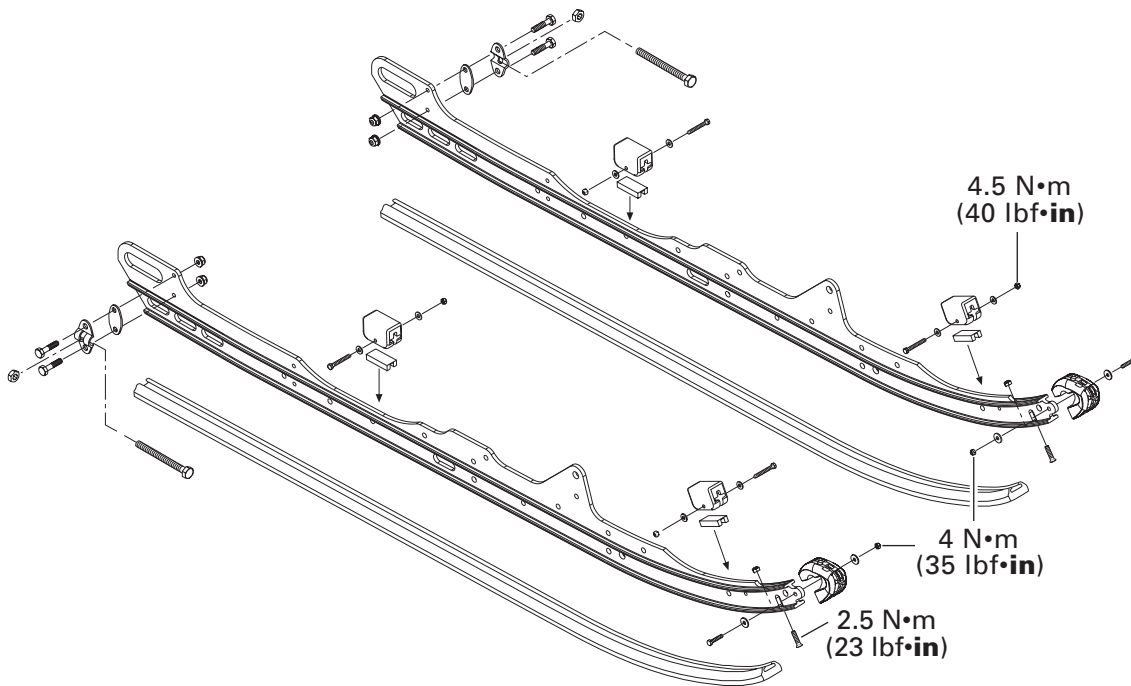
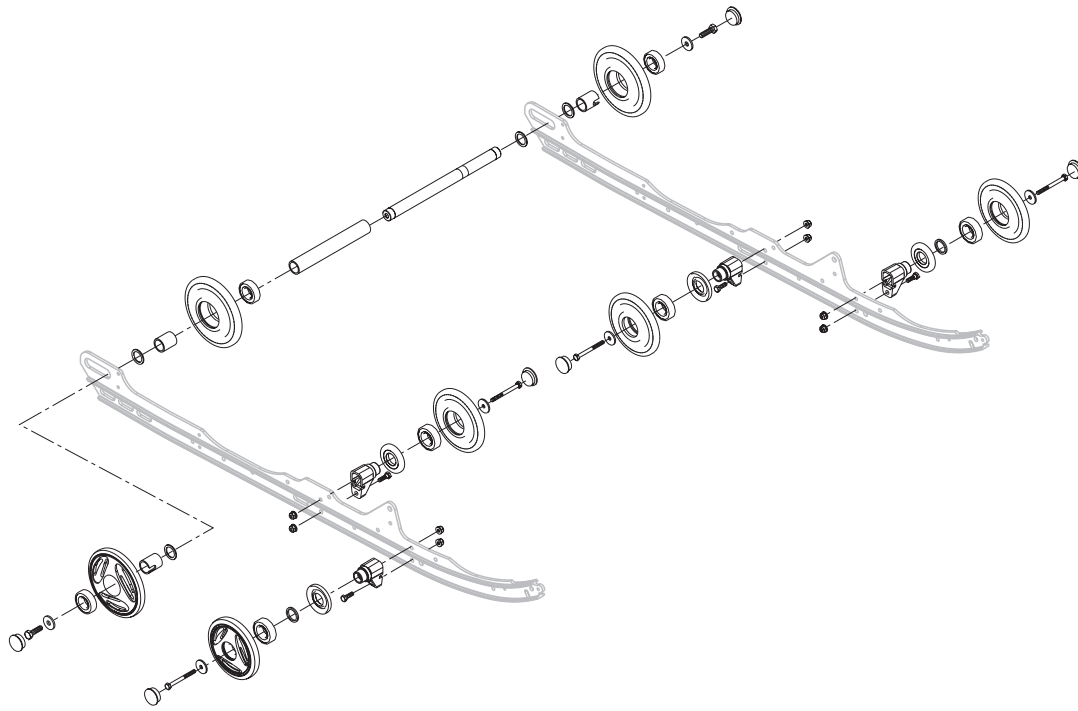

A32F4CT

RAILS AND IDLER WHEELS

Section 09 REAR SUSPENSION
Subsection 01 (SC SUSPENSION)

Expedition (Sport)/GTX/Summit Fan Cooled Models

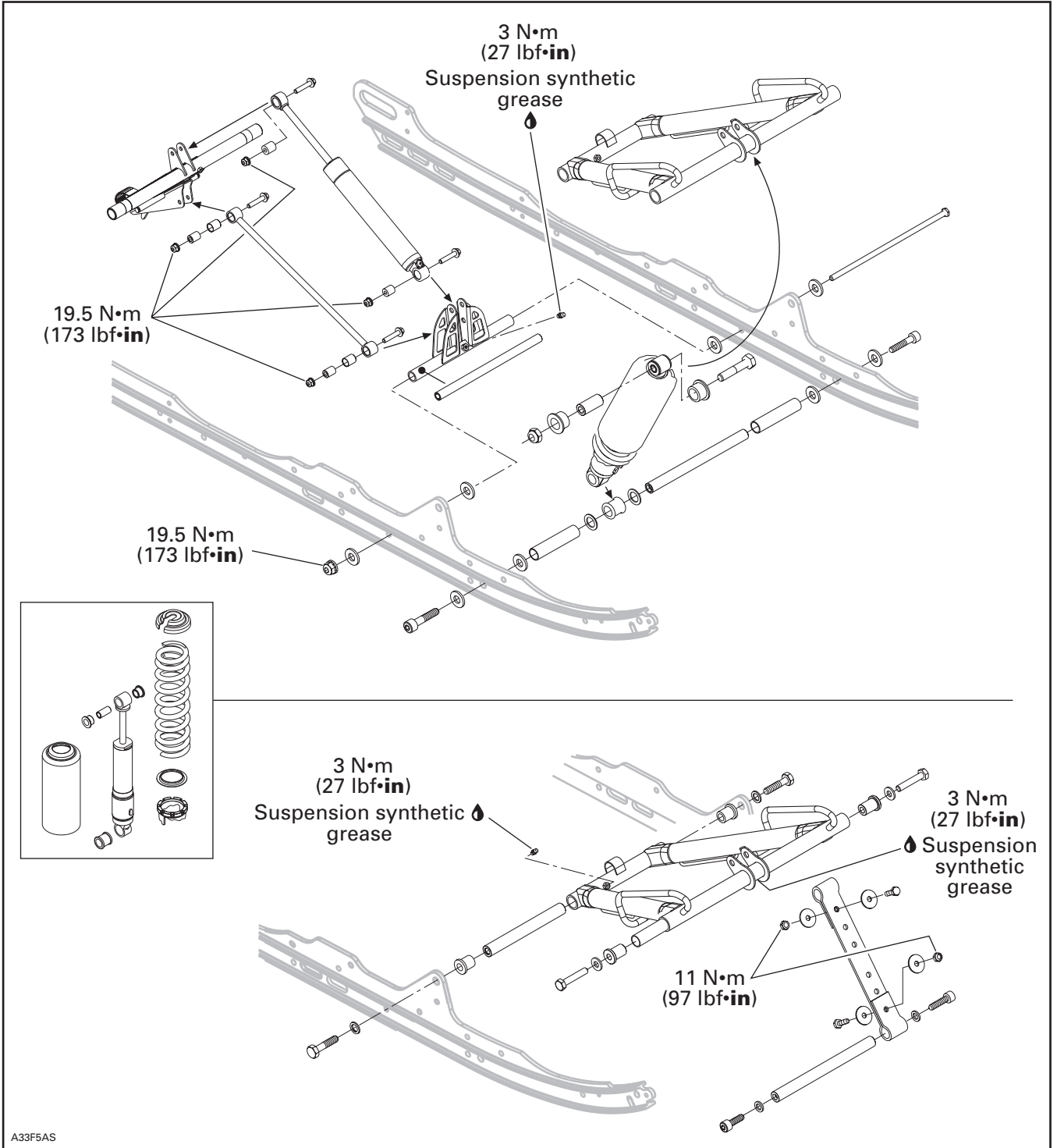

A33F5AS

ARMS AND SHOCK ABSORBERS

Section 09 REAR SUSPENSION

Subsection 01 (SC SUSPENSION)

Summit Liquid Cooled Models

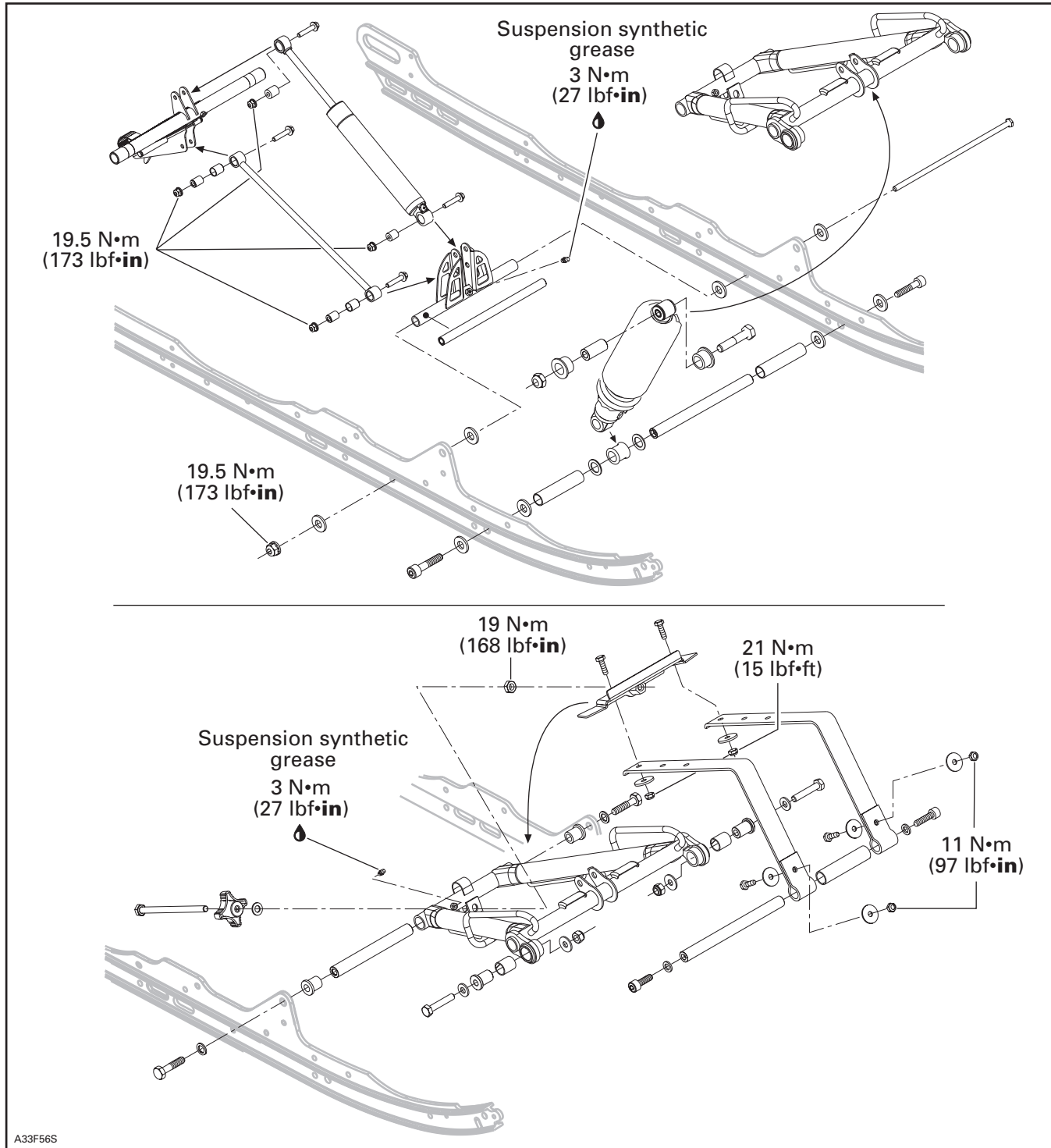

ARMS AND SHOCK ABSORBERS

Section 09 REAR SUSPENSION
Subsection 01 (SC SUSPENSION)

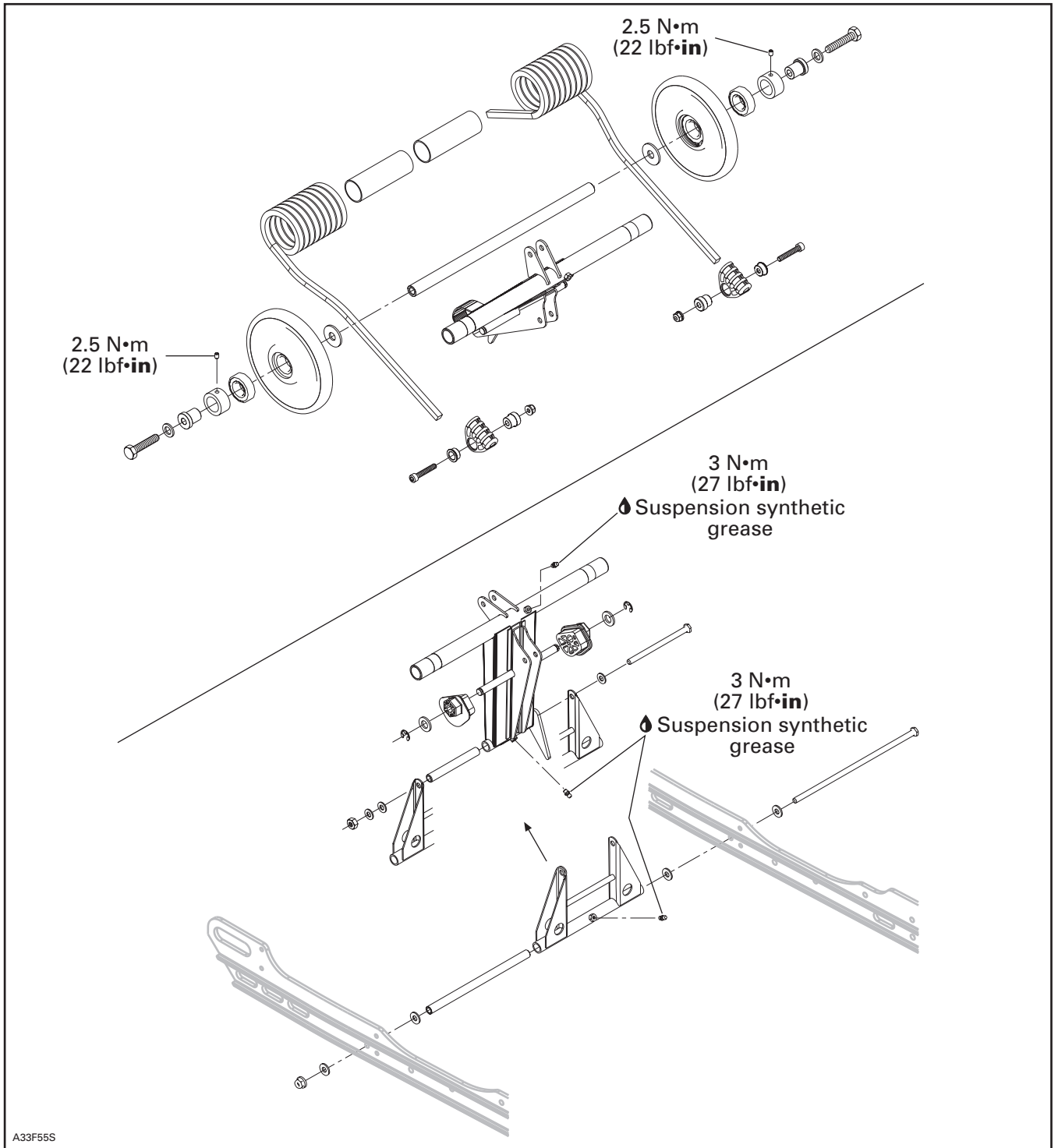

REAR ARM, SPRINGS AND TOP IDLER WHEELS

Section 09 REAR SUSPENSION

Subsection 01 (SC SUSPENSION)

AXLE SELF-LOCKING SCREWS REMOVAL

CAUTION: These self-locking screws must always be replaced by new ones everytime they are removed.

NOTE: To prevent axle from turning when unscrewing self-locking screws, proceed as follows:

- Remove one self-locking screw then install a 10 mm shorter non-self-locking one in place. Torque as specified in exploded view.
- Remove the opposite self-locking screw.
- Remove the temporary installed non-self-locking screw.
- If it doesn't work, heat bolt head to melt threadlocker.

REAR AXLE REMOVAL

Lift rear of vehicle and support it off the ground.

Remove screws on rear axle.

Completely loosen track tension.

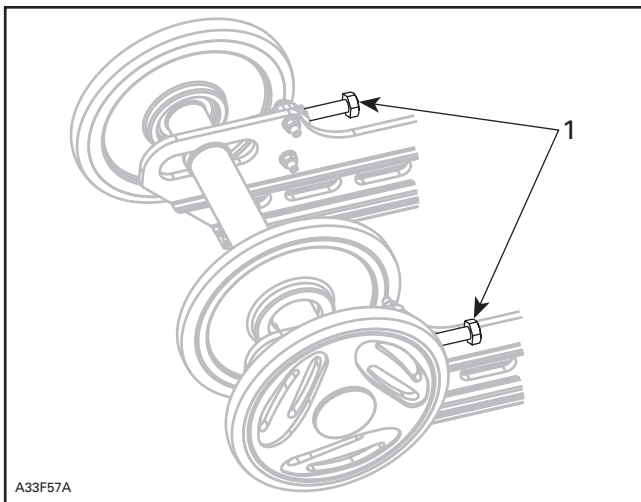

1. Completely loosen track tension

Pull out rear axle from RH side of vehicle.

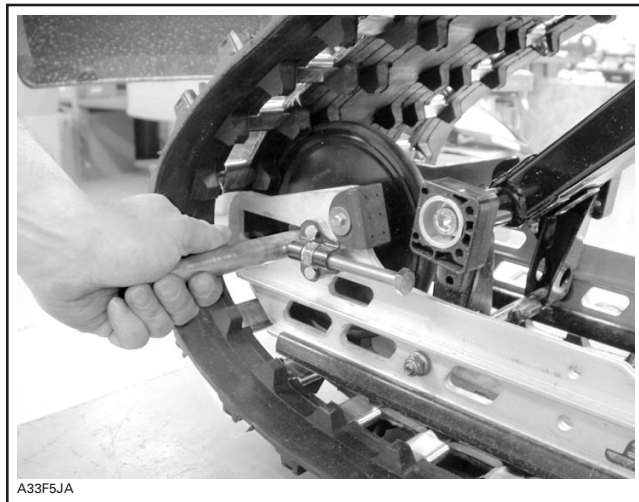

TYPICAL — PULL OUT REAR AXLE

REAR AXLE INSTALLATION

Installation is the reverse of removal procedure. Pay attention to the following details.

Hole of outer bushing must face adjustment screw.

Make sure to reinstall washer on each side of runner.

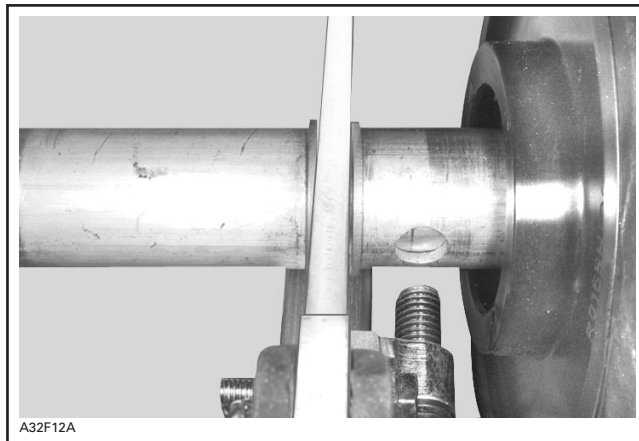

OUTER BUSHING POSITION

REAR SHOCK ABSORBER REMOVAL

Lift rear of vehicle and support it off the ground.

Remove shock upper and lower bolt and nut

Section 09 REAR SUSPENSION

Subsection 01 (SC SUSPENSION)

NOTE: If necessary, to ease shock removal, unfasten one end of stopper straps to release shock pressure.

Remove rear shock absorber.

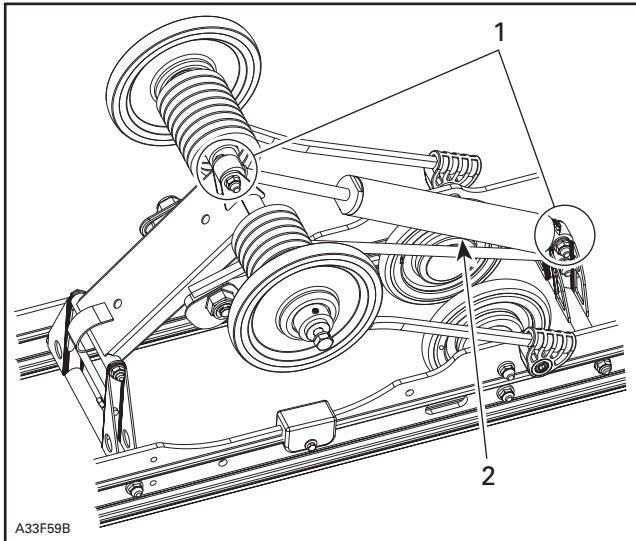

TYPICAL

1. Upper/lower bolt and nut
2. Rear shock absorber

REAR SHOCK ABSORBER INSTALLATION

Installation is the reverse of removal procedure.

CAUTION: Take care not to damage grease fitting.

Respect the following tightening torque specification:

DESCRIPTION	TIGHTENING TORQUE
Shock upper and lower nut	19.5 N•m (173 lbf•in)

FRONT SHOCK ABSORBER REMOVAL

Lift rear of vehicle and support it off the ground.

Unfasten one end of stopper strap(s) or loosen the adjuster knob to release shock pressure.

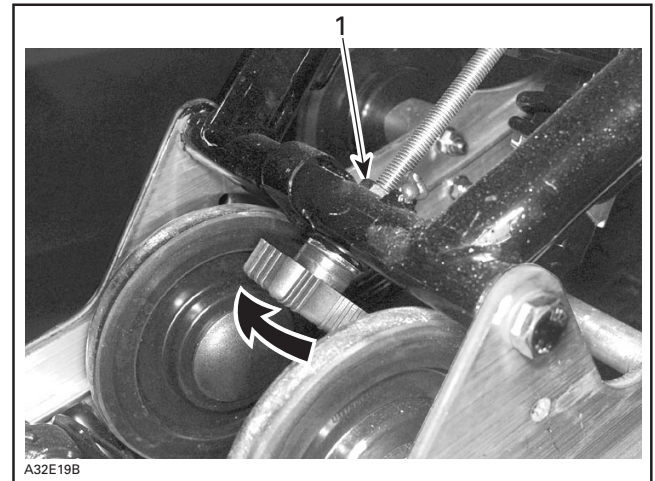

SUMMIT LIQUID COOLED MODELS

1. Loosen lock nut, turn adjuster knob counterclockwise

Unbolt front shock from the top.

Remove the front idler wheels to gain access to the axle retaining self-locking screws.

Unbolt axle screws and slide out axle to remove shock.

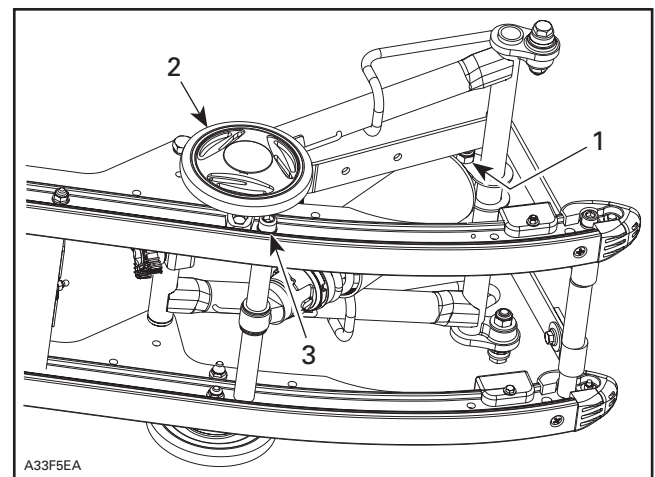

TYPICAL

1. Front shock upper bolt and nut
2. Idler wheel
3. Axle screw

FRONT SHOCK ABSORBER INSTALLATION

Installation is the reverse of removal procedure.

Respect the following tightening torque specification.

Section 09 REAR SUSPENSION

Subsection 01 (SC SUSPENSION)

DESCRIPTION	TIGHTENING TORQUE
Adjuster lock nut	19 N•m (168 lbf•in)
Stopper straps nuts (on Summit strap adjuster)	21 N•m (15 lbf•ft)
Stopper strap(s) nuts	11 N•m (97 lbf•in)

REAR SPRING REMOVAL

Lift rear of vehicle and support it off the ground.
Decrease spring preload by turning cams accordingly.
Unbolt rear arm top axle from chassis.
Remove spring supports.

WARNING

Supports are spring loaded.



TYPICAL — REMOVE SPRING SUPPORTS

Loosen set screw from locking rings.
Remove the following on both sides:

- locking ring
- top idler wheel
- spring.

REAR SPRING INSTALLATION

Installation is the reverse of removal procedure.
Pay attention to the following details.

At assembly, respect THIS SIDE OUT inscription on top idler wheels.

At assembly, make sure that spring end is in cam adjuster.

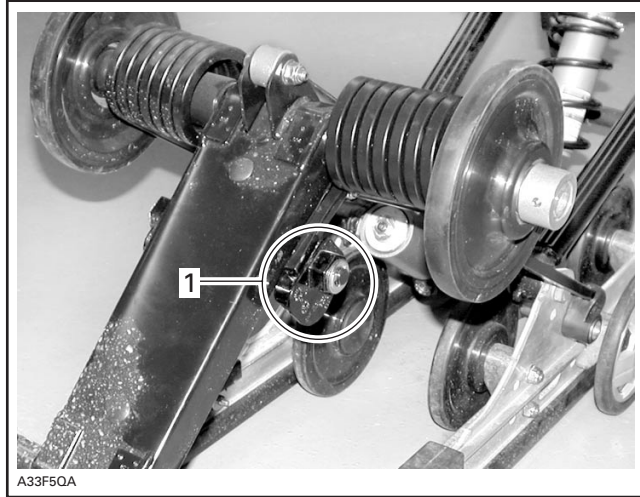

A33F5QA

TYPICAL — ON BOTH SIDES
1. Spring end in cam adjuster

CAUTION: To avoid track damage, spring supports must be mounted upward.

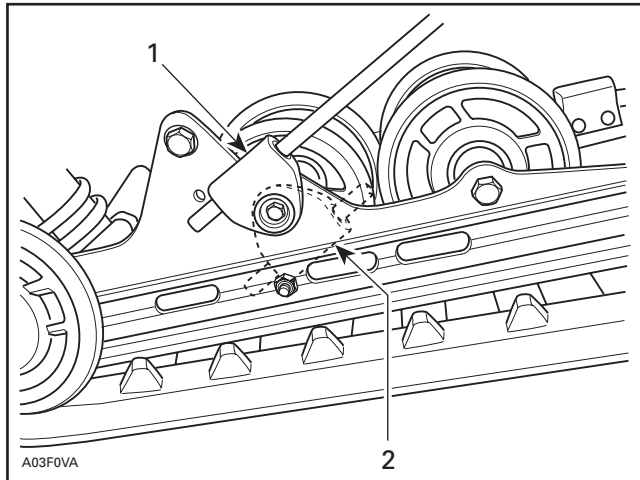

A03F0VA

TYPICAL — RIGHT SIDE SHOWN
1. Right position: upward
2. Wrong position

Respect the following tightening torque specification:

DESCRIPTION	TIGHTENING TORQUE
Locking ring set screw	2.5 N•m (22 lbf•in)

SLIDER SHOE VERIFICATION

Molding line is the wear limit indicator.

Section 09 REAR SUSPENSION

Subsection 01 (SC SUSPENSION)

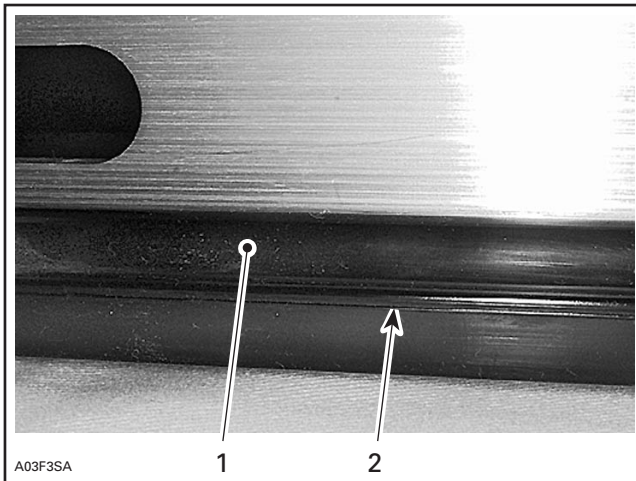

TYPICAL

1. Slider shoe
2. Molding line (wear limit indicator)

Replace slider shoes when wear limit is reached.

CAUTION: Slider shoes must always be replaced in pairs.

SLIDER SHOE REMOVAL

Lift rear of vehicle and support it off the ground.
Completely loosen track tension.
Remove front runners nut and screw.



TYPICAL — REMOVE NUT AND SCREW

Align track window with slider shoe.

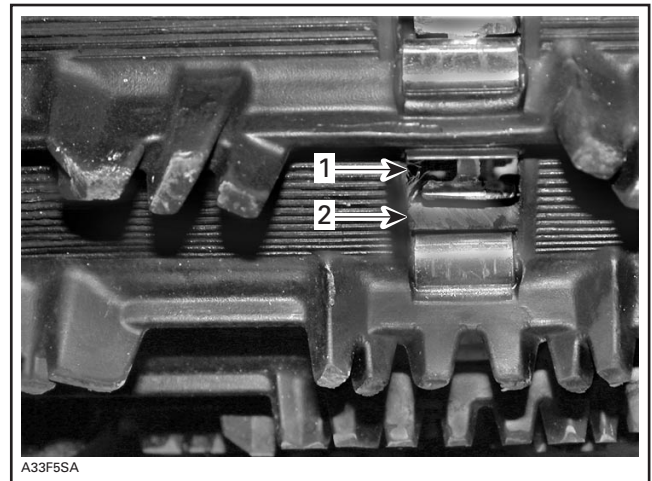

TYPICAL

1. Track window
2. Slider shoe

Using a pry bar or screw driver, push slider shoe until it comes in contact with track.

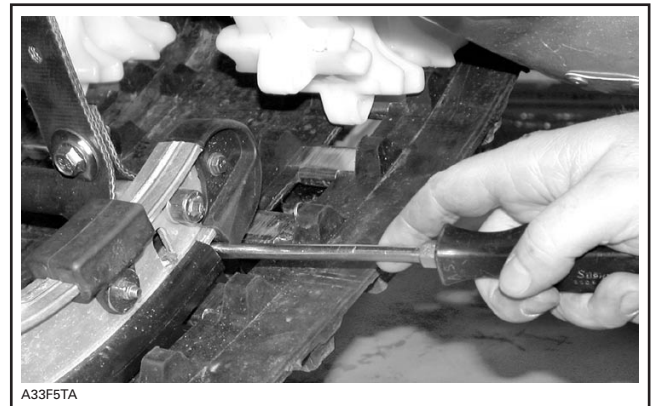

TYPICAL — PUSH ON SLIDER SHOE

Using locking pliers, pull slider shoe thru track window to remove.

NOTE: If necessary, lubricate track window to facilitate slider shoe removal.

Section 09 REAR SUSPENSION

Subsection 01 (SC SUSPENSION)



TYPICAL — PULL ON SLIDER SHOE TO REMOVE

SLIDER SHOE INSTALLATION

Installation is reverse of removal procedure. Pay attention to the following details.

Make sure to insert slider shoe end with hole first. Respect the following tightening torque specification:

DESCRIPTION	TIGHTENING TORQUE
Slider shoe nut	2.5 N•m (22 lbf•in)

SUSPENSION REMOVAL

Lift rear of vehicle and support it off the ground. Completely loosen track tension. Remove rear arm top axle bolts from chassis. Remove bolts retaining front arm to tunnel.

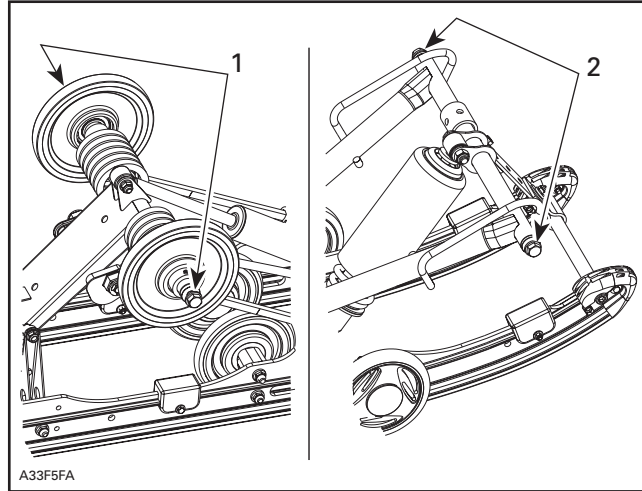

TYPICAL
1. Rear arm bolts
2. Front arm bolts

Lift rear of vehicle until front arm as enough clearance to pass underneath tunnel.

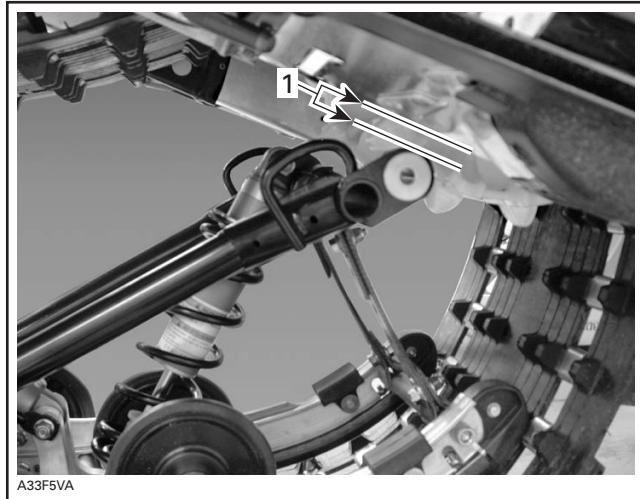

TYPICAL
1. Enough clearance

Section 09 REAR SUSPENSION

Subsection 01 (SC SUSPENSION)

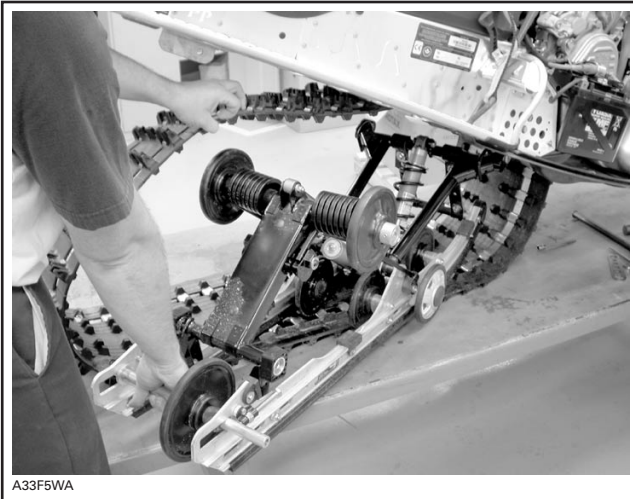

A33F5WA

TYPICAL — REMOVE SUSPENSION

SUSPENSION INSTALLATION

Installation is the reverse of removal procedure. Pay attention to the following details.

Inspect track thoroughly before reinstalling suspension. Refer to TRACK.

Install suspension into track with front portion first.

Adjust track tension.

FRONT ARM REMOVAL

NOTE: Front arm can be removed with suspension in place.

Lift rear of vehicle and support it off the ground.

Remove the following:

- shock upper bolt and nut
- front arm lower bolts and washers
- unfasten one end of stopper strap(s)
- remove front arm upper bolts, nuts and washers.

Remove front arm.

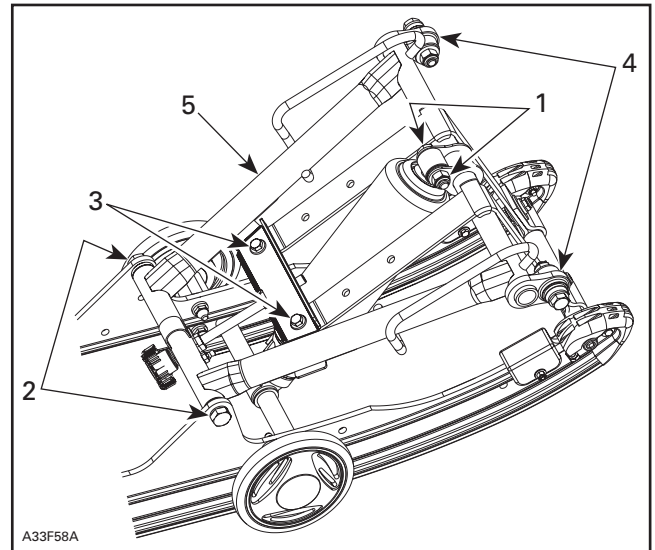

A33F58A

SUMMIT LIQUID COOLED MODELS

1. Shock upper bolt and nut
2. Front arm lower bolts and washers
3. Unfasten one end of stopper straps
4. Front arm upper bolts, nuts and washers
5. Front arm

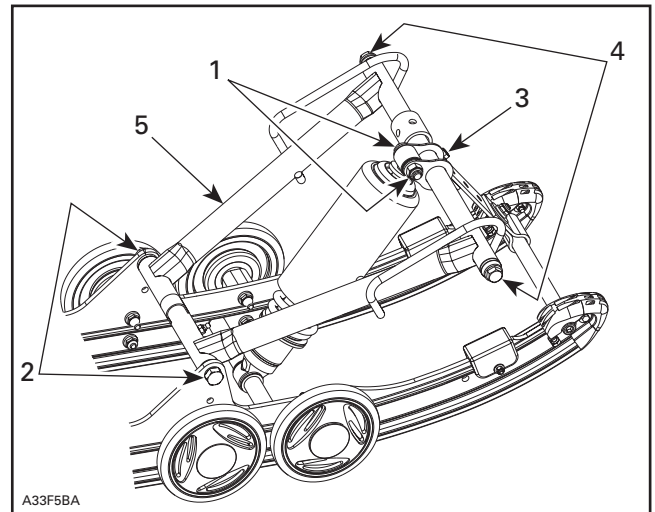

A33F5BA

EXPEDITION/GTX/SUMMIT FAN COOLED MODELS

1. Shock upper bolt and nut
2. Front arm lower bolts and washers
3. Unfasten one end of stopper strap
4. Front arm upper bolts, nuts and washers
5. Front arm

FRONT ARM INSTALLATION

Installation is reverse of removal procedure.

Respect the following tightening torque specifications:

Section 09 REAR SUSPENSION

Subsection 01 (SC SUSPENSION)

DESCRIPTION	TIGHTENING TORQUE
Stopper strap nuts (on Summit strap adjuster)	21 N•m (15 lbf•ft)
Stopper strap nuts	11 N•m (97 lbf•in)

REAR ARM/PIVOT ARM REMOVAL

NOTE: Rear arm can be removed with suspension in place.

For rear arm removal, remove the following:

- shock upper bolt and nut
- throttle rod upper bolt and nut
- rear springs (refer to procedure above in this section)
- screws and washers holding rear arm to pivot arm

Remove rear arm.

For pivot arm removal, remove the following:

- bolt, nut and washers holding pivot arm to runners

Remove pivot arm.

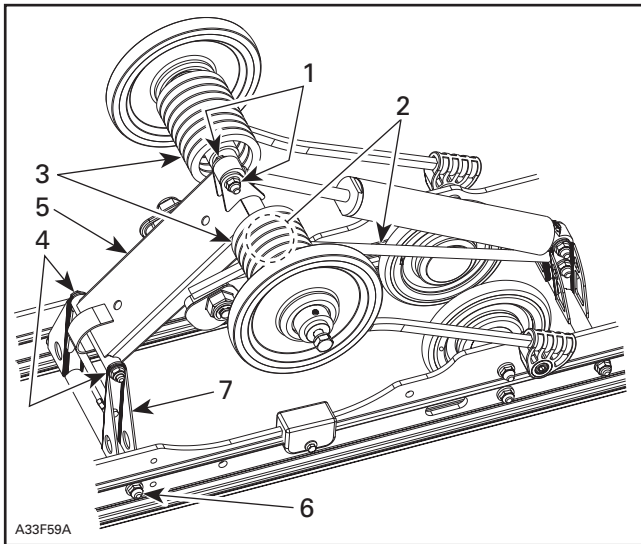

TYPICAL

1. Shock upper bolt and nut
2. Throttle rod upper bolt and nut
3. Rear springs
4. Rear arm/pivot arm screws and washers
5. Rear arm
6. Pivot arm/runners bolts, nuts and washers
7. Pivot arm

REAR ARM INSTALLATION

Installation is reverse of removal procedure. Pay attention to the following details.

At installation, rear arm stroke limiter must be on rear side.

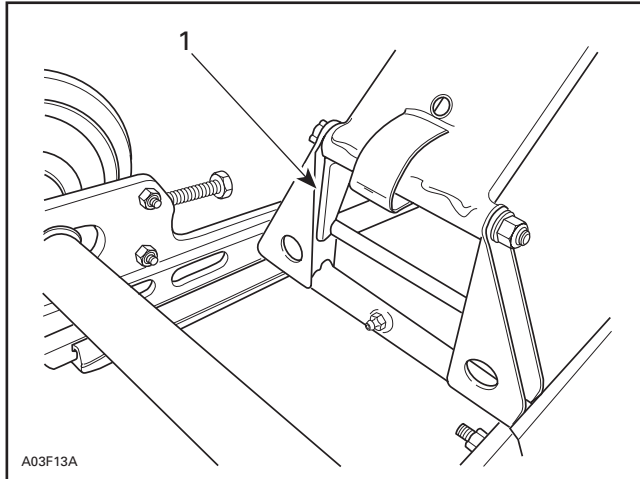

1. Stroke limiter on rear side

Respect the following tightening torque specifications:

DESCRIPTION	TIGHTENING TORQUE
Locking ring set screw	2.5 N•m (22 lbf•in)
Rear arm shock upper nut	19.5 N•m (173 lbf•in)
Throttle rod upper nut	19.5 N•m (173 lbf•in)

STOPPER STRAP

Inspect strap for wear or cracks, bolt and nut for tightness. If loose, inspect hole for deformation. Replace as required.

Make sure it is attached through proper hole from the end.

Section 09 REAR SUSPENSION

Subsection 01 (SC SUSPENSION)

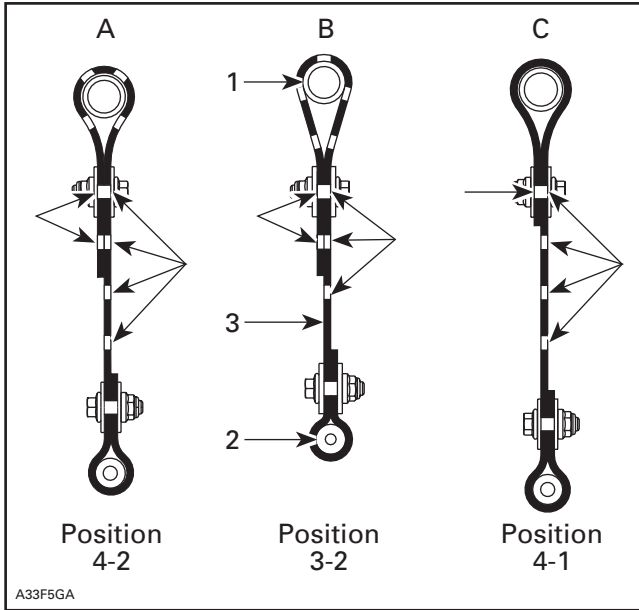

FAN COOLED MODELS

1. Front arm (top)
2. Front axle
3. Rear of vehicle

- A. GTX/Expedition
 B. Summit
 C. GTX (EUR)/Summit (EUR)

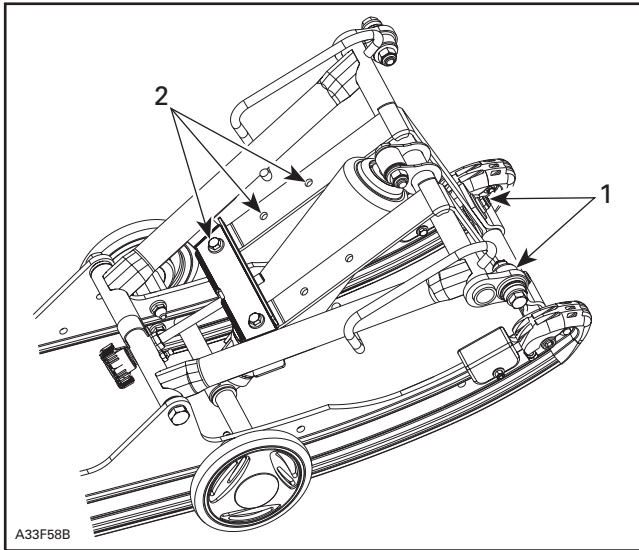

TYPICAL — SUMMIT LIQUID COOLED MODELS

1. No adjustment possible
2. 3 adjustments possible

DESCRIPTION	TIGHTENING TORQUE
Stopper strap nuts (on Summit strap adjuster)	21 N•m (15 lbf•ft)
Stopper strap nuts	11 N•m (97 lbf•in)

RIDE ADJUSTMENT

Refer to the appropriate *Operator's Guide*.

LUBRICATION

Lubricate front and rear arms at grease fittings using suspension synthetic grease (P/N 293 550 033).

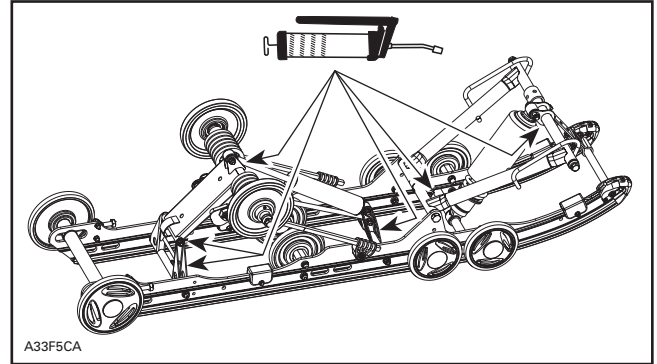

EXPEDITION/GTX/SUMMIT FAN COOLED MODELS

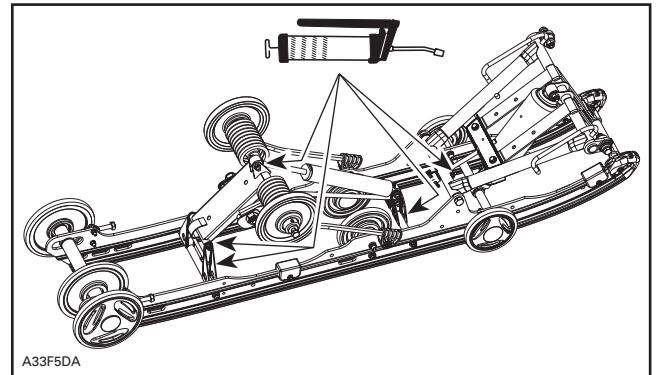

SUMMIT LIQUID COOLED MODELS

SC 3 SUSPENSION

SERVICE PRODUCTS

<u>Description</u>	<u>Part Number</u>	<u>Page</u>
suspension synthetic grease	293 550 033	406

Section 09 REAR SUSPENSION

Subsection 02 (SC 3 SUSPENSION)

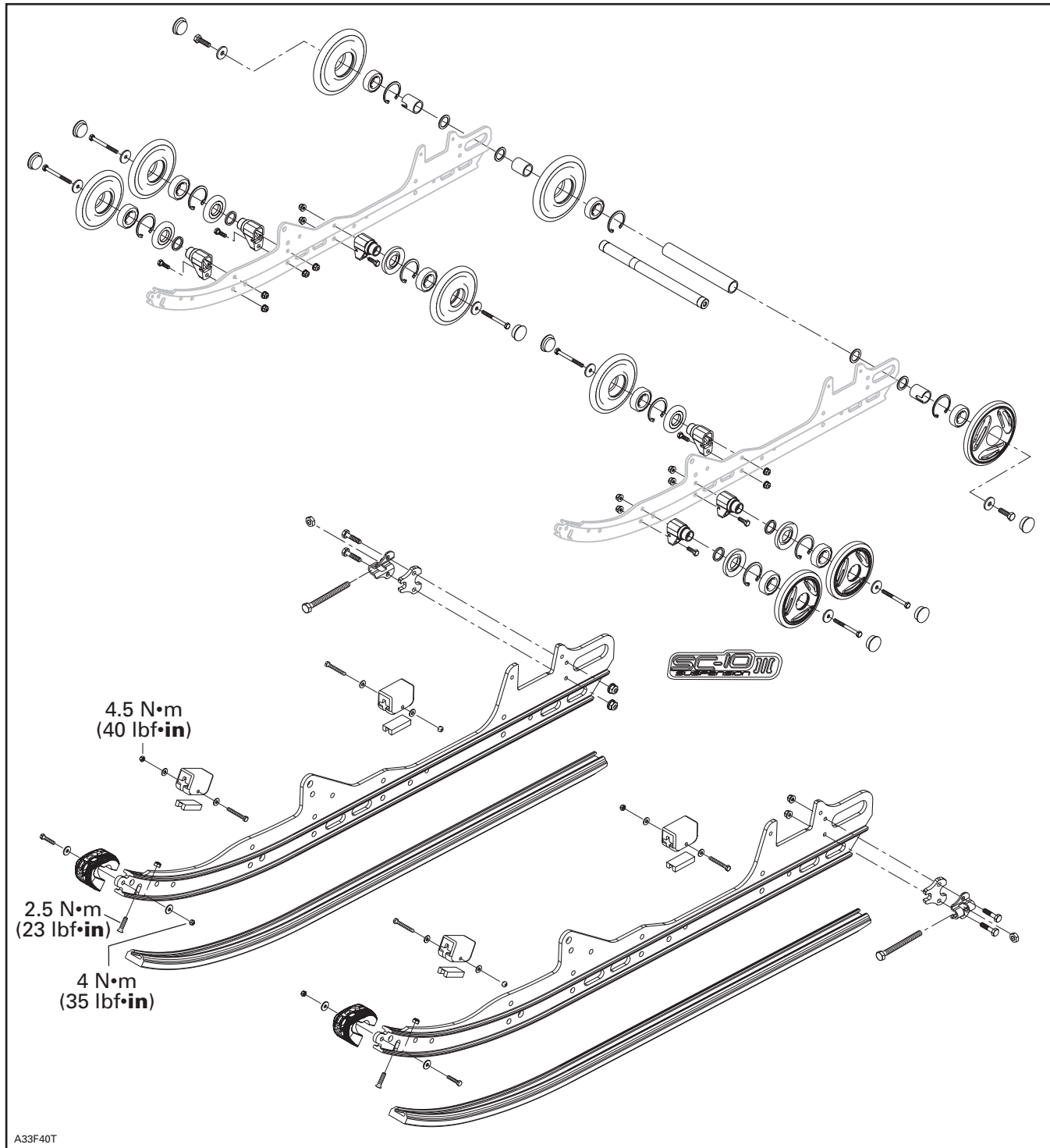

RAILS AND IDLER WHEELS

Section 09 REAR SUSPENSION
Subsection 02 (SC 3 SUSPENSION)

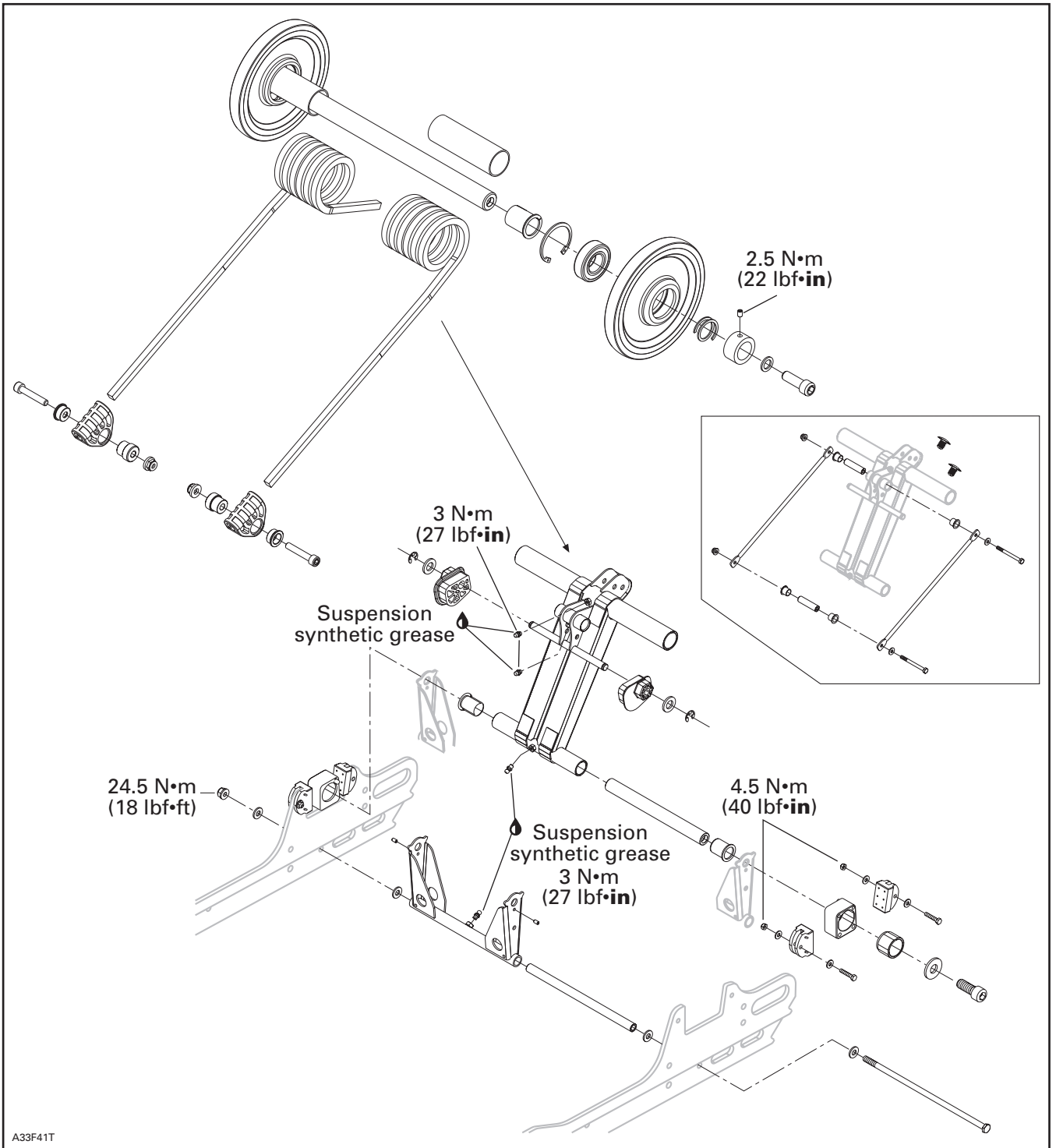

REAR ARM AND UPPER IDLER WHEELS

Section 09 REAR SUSPENSION
Subsection 02 (SC 3 SUSPENSION)

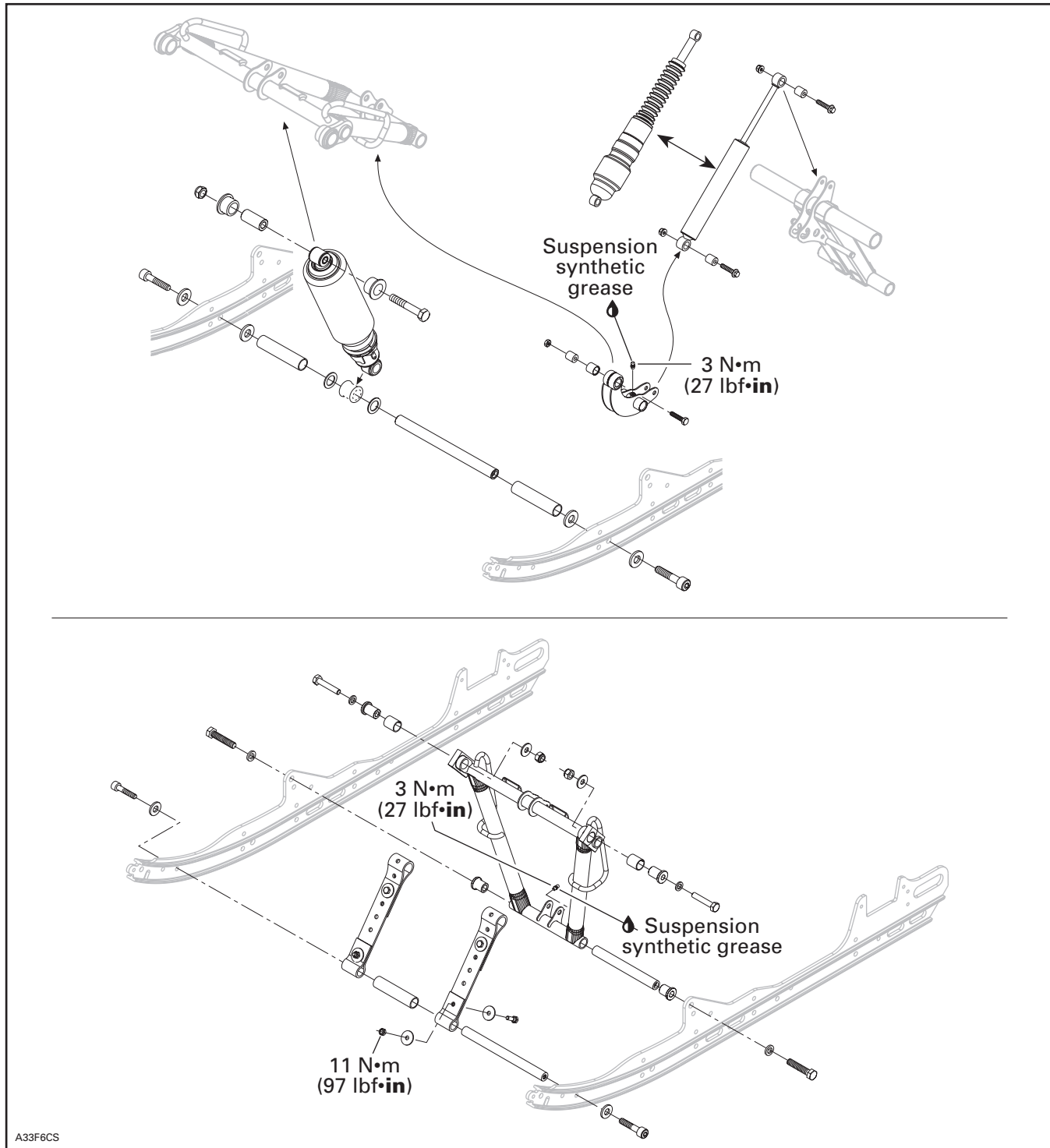

A33F6CS

FRONT ARM AND SHOCK ABSORBERS

AXLE SELF-LOCKING SCREWS REMOVAL

CAUTION: These self-locking screws must always be replaced by new ones everytime they are removed.

NOTE: To prevent axle from turning when unscrewing self-locking screws, proceed as follows:

- Remove one self-locking screw then install a 10 mm shorter non-self-locking one in place. Torque as specified in exploded view.
- Remove the opposite self-locking screw.
- Remove the temporary installed non-self-locking screw.
- If it doesn't work, heat bolt head to melt threadlocker.

REAR AXLE REMOVAL

Lift rear of vehicle and support it off the ground.
Remove screws on rear axle.
Completely loosen track tension.

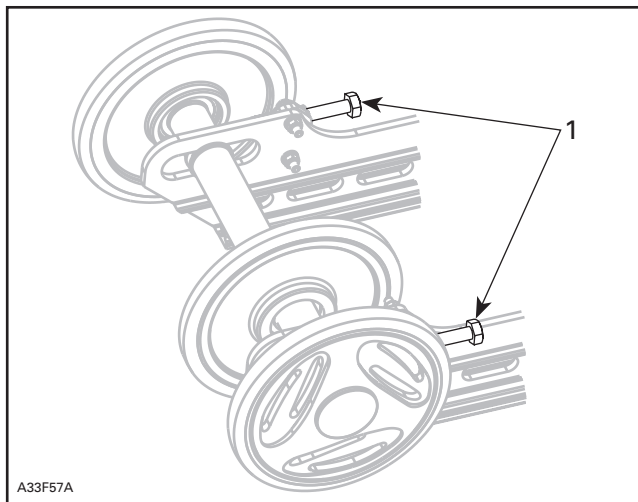

TYPICAL
1. Completely loosen track tension

Pull out rear axle from RH side of vehicle.

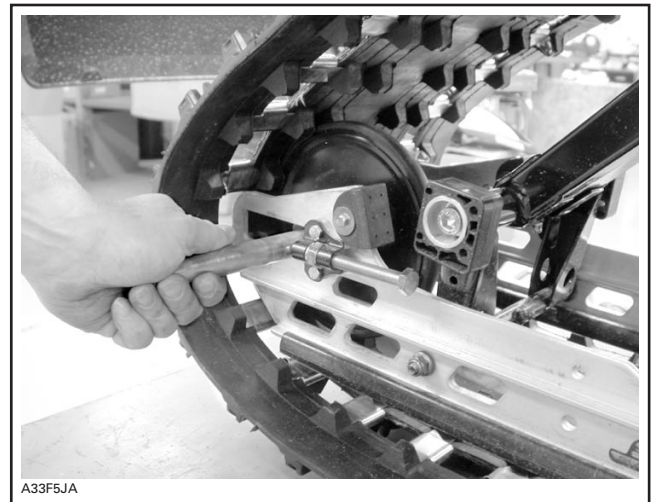

TYPICAL — PULL OUT REAR AXLE

REAR AXLE INSTALLATION

Installation is reverse of removal procedure. Pay attention to the following details.

Hole of outer bushing must face adjustment screw.

Make sure to reinstall washer on each side of runner.

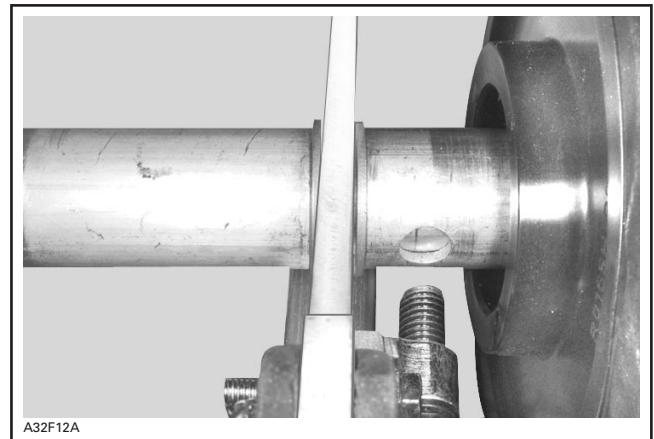

OUTER BUSHING POSITION

REAR SHOCK ABSORBER REMOVAL

Lift rear of vehicle and support it off the ground.
Remove shock upper and lower bolt and nut

Section 09 REAR SUSPENSION

Subsection 02 (SC 3 SUSPENSION)

NOTE: If necessary, to ease shock removal, unfasten one end of stopper straps to release shock pressure.

Remove rear arm shock.

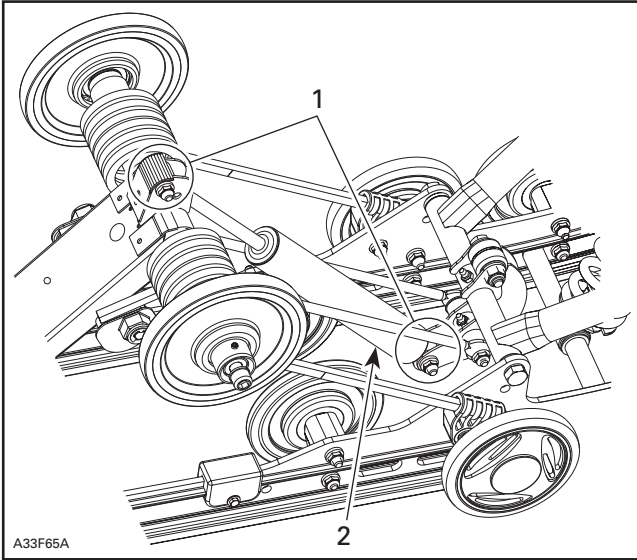

TYPICAL

1. Upper/lower bolt and nut
2. Rear shock absorber

REAR SHOCK ABSORBER INSTALLATION

Installation is reverse of removal procedure.

CAUTION: Take care not to damage grease fitting.

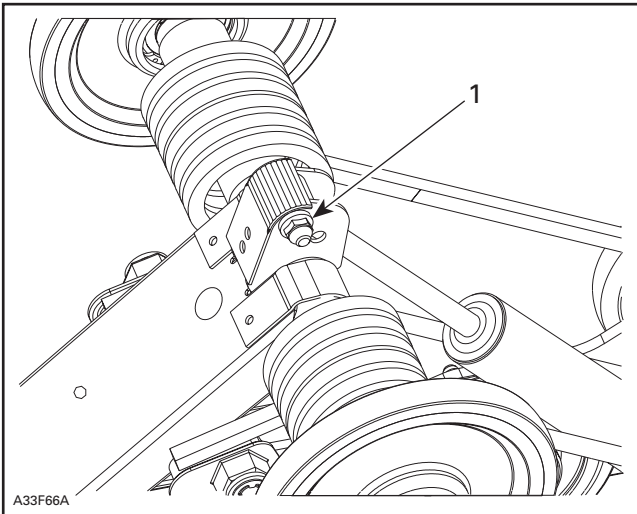

REAR SHOCK ABSORBER POSITION

1. Shock installed using upper hole

FRONT SHOCK ABSORBER REMOVAL

Lift rear of vehicle and support it off the ground.

Unfasten one end of stopper straps to release shock pressure.

Unbolt front shock from the top.

Remove the front idler wheels to gain access to the axle retaining self-locking screws.

Unbolt axle screws and slide out axle to remove shock.

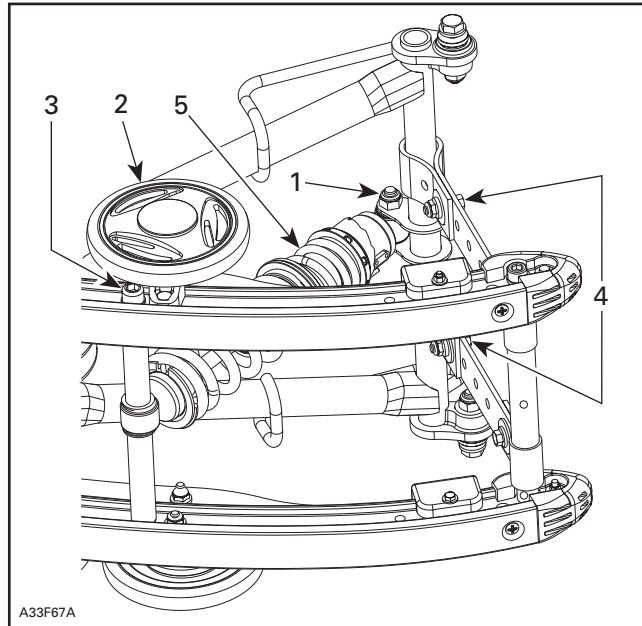

TYPICAL

1. Front shock upper bolt and nut
2. Idler wheel
3. Axle screw
4. Unfasten one end of stopper straps
5. Front shock

FRONT SHOCK ABSORBER INSTALLATION

Installation is reverse of removal procedure.

Respect the following tightening torque specification:

DESCRIPTION	TIGHTENING TORQUE
Stopper strap(s) nuts	11 N•m (97 lbf•in)

REAR SPRING REMOVAL

Lift rear of vehicle and support it off the ground.

Section 09 REAR SUSPENSION

Subsection 02 (SC 3 SUSPENSION)

Decrease spring preload by turning cams accordingly.

Loosen rear arm top axle from chassis.

Remove idler wheels to have access to spring supports screws.

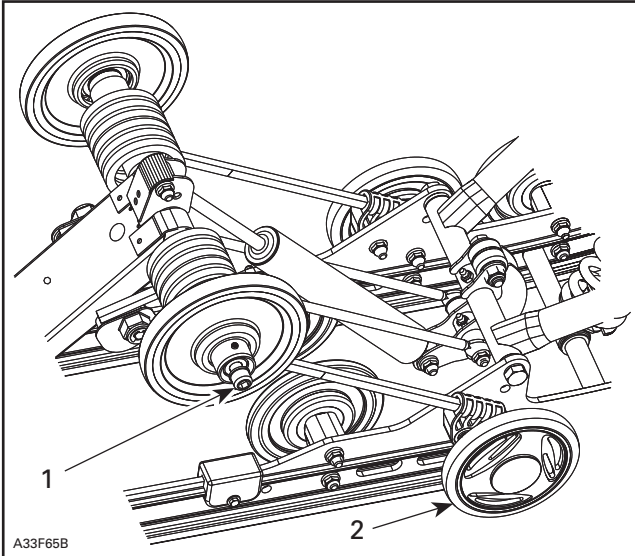

TYPICAL

1. Loosen rear arm top axle from chassis
2. Remove idler wheels (if necessary)

Remove spring supports.

WARNING

Supports are spring loaded.



REMOVE SPRING SUPPORTS

Remove screws and washers from rear arm top axle.

Loosen set screw from locking rings.

Remove the following on both sides:

- locking ring
- axle spring
- top idler wheel
- rear springs.

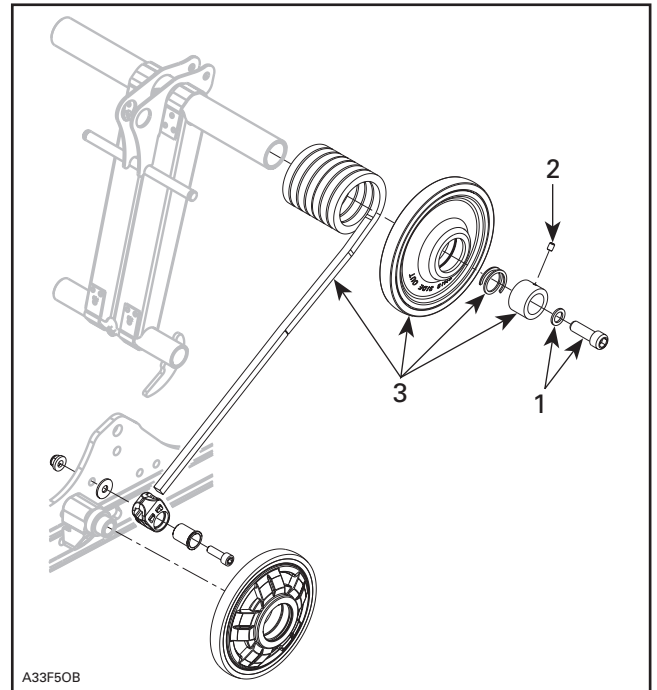

TYPICAL — ON BOTH SIDES

1. Remove screws
2. Loosen set screw
3. Remove the following

REAR SPRING INSTALLATION

Installation is reverse of removal procedure. Pay attention to the following details.

At assembly, respect THIS SIDE OUT inscription on top idler wheels.

At assembly, make sure that spring end is in cam adjuster.

Section 09 REAR SUSPENSION

Subsection 02 (SC 3 SUSPENSION)

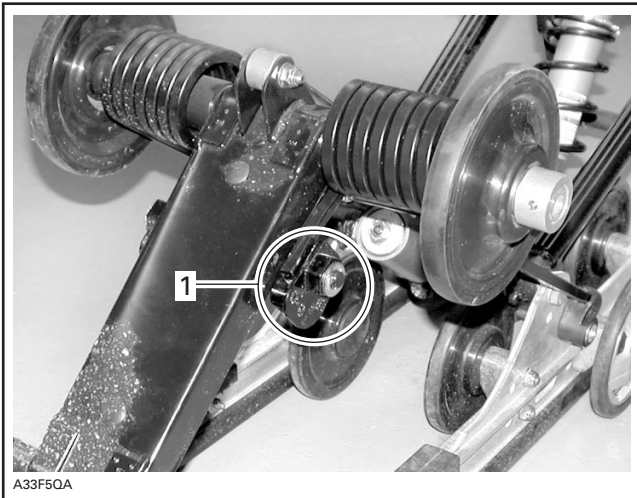

ON BOTH SIDES
1. Spring end in cam adjuster

CAUTION: To avoid track damage, spring supports must be mounted upward.

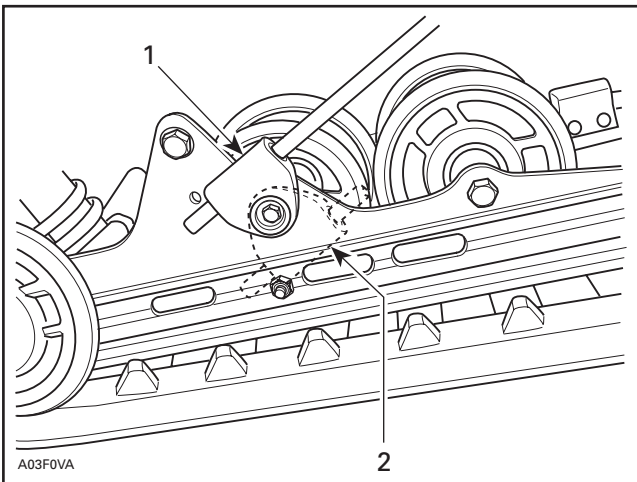

TYPICAL — RIGHT SIDE SHOWN
1. Right position: upward
2. Wrong position

Respect the following tightening torque specification:

DESCRIPTION	TIGHTENING TORQUE
Locking ring set screw	2.5 N•m (22 lbf•in)

SLIDER SHOE VERIFICATION

Molding line is the wear limit indicator.

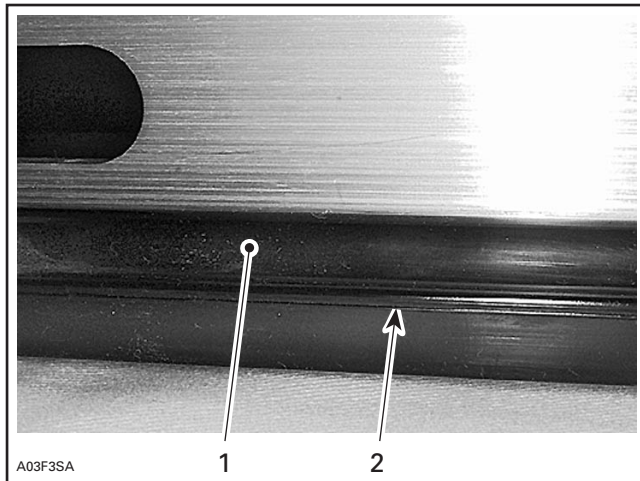

TYPICAL
1. Slider shoe
2. Molding line (wear limit indicator)

Replace slider shoes when wear limit is reached.

CAUTION: Slider shoes must always be replaced in pairs.

SLIDER SHOE REMOVAL

Lift rear of vehicle and support it off the ground.
Completely loosen track tension.
Remove front runners nut and screw.



TYPICAL — REMOVE NUT AND SCREW

Align track window with slider shoe.

Section 09 REAR SUSPENSION

Subsection 02 (SC 3 SUSPENSION)

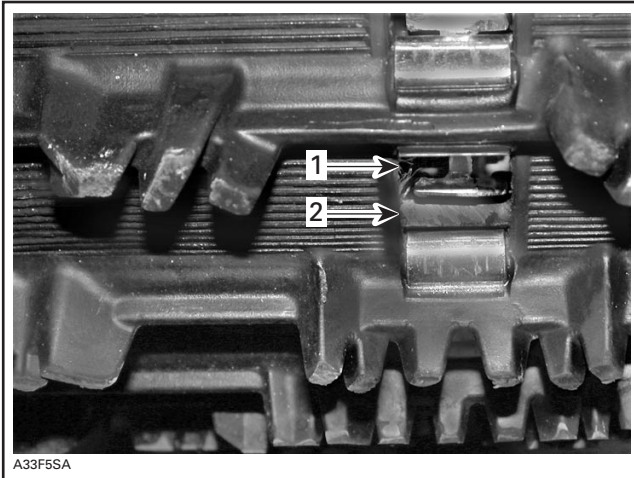

TYPICAL
 1. Track window
 2. Slider shoe

Using a pry bar or screw driver, push slider shoe until it comes in contact with track.

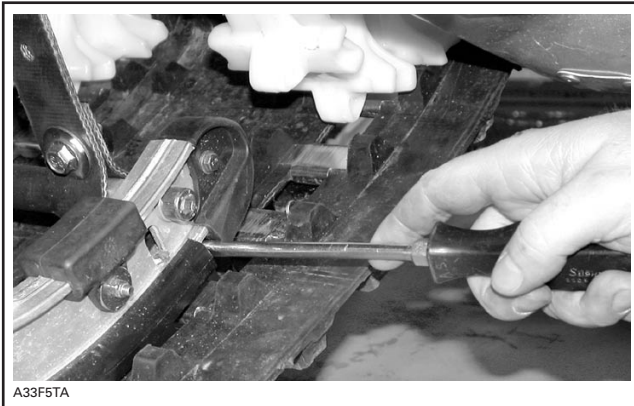

TYPICAL — PUSH ON SLIDER SHOE

Using locking pliers, pull slider shoe thru track window to remove.

NOTE: If necessary, lubricate track window to facilitate slider shoe removal.



TYPICAL — PULL ON SLIDER SHOE TO REMOVE

SLIDER SHOE INSTALLATION

Installation is reverse of removal procedure. Pay attention to the following details.

Make sure to insert slider shoe end with hole first. Respect the following tightening torque specification:

DESCRIPTION	TIGHTENING TORQUE
Slider shoe nut	2.5 N•m (22 lbf•in)

SUSPENSION REMOVAL

Lift rear of vehicle and support it off the ground.

Completely loosen track tension.

Remove rear arm top axle bolts from chassis.

Remove bolts retaining front arm to tunnel.

Section 09 REAR SUSPENSION

Subsection 02 (SC 3 SUSPENSION)

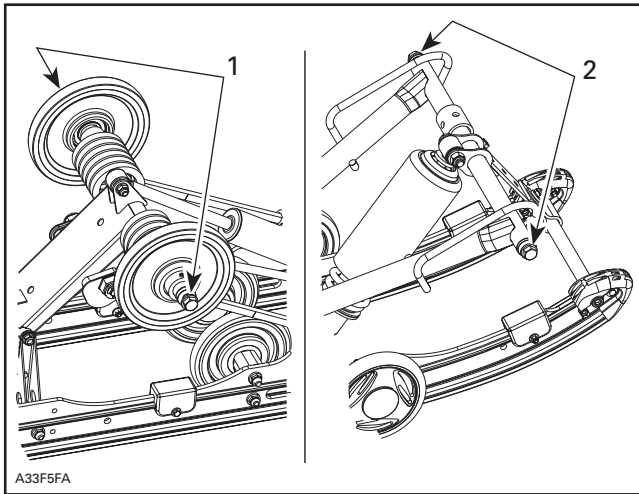

TYPICAL

1. Rear arm bolts
2. Front arm bolts

Lift rear of vehicle until front arm as enough clearance to pass underneath tunnel.



TYPICAL

1. Enough clearance

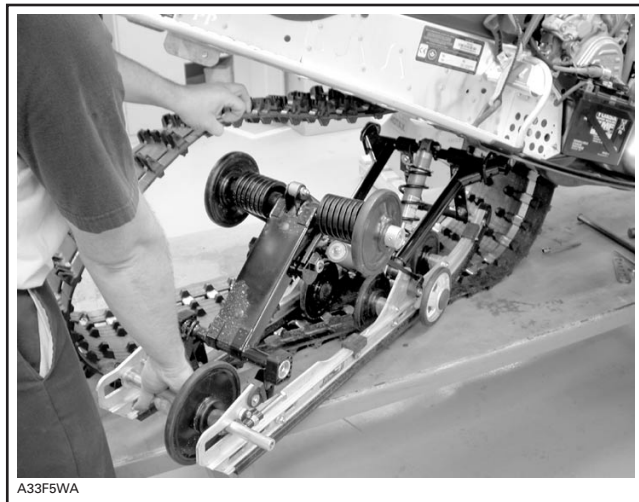

TYPICAL — REMOVE SUSPENSION

SUSPENSION INSTALLATION

Installation is reverse of removal procedure. Pay attention to the following details.

Inspect track thoroughly before reinstalling suspension. Refer to TRACK.

Install assembled suspension into track with front portion first.

Adjust track tension.

FRONT ARM REMOVAL

NOTE: Front arm can be removed with suspension assembly in place.

Lift rear of vehicle and support it off the ground.

Remove the following:

- shock upper bolt and nut
- front arm lower bolts and washers
- unfasten one end of stopper strap(s)
- remove front arm upper bolts, nuts and washers.

Remove front arm.

Section 09 REAR SUSPENSION

Subsection 02 (SC 3 SUSPENSION)

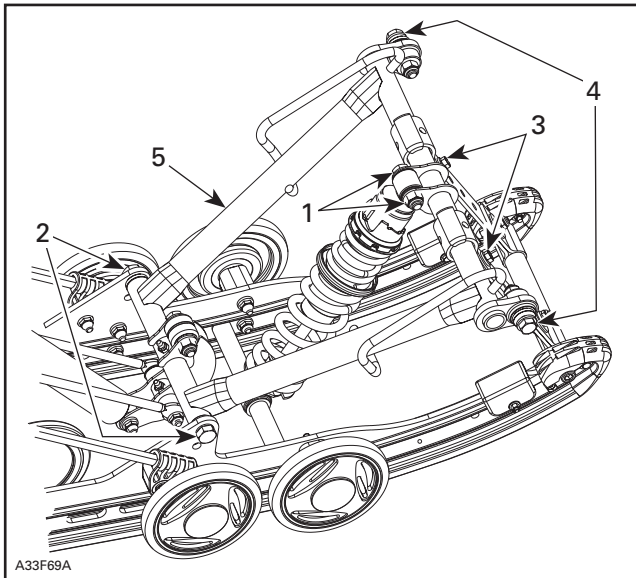

TYPICAL

1. Shock upper bolt and nut
2. Front arm lower bolts and washers
3. Unfasten one end of stopper straps
4. Front arm upper bolts, nuts and washers
5. Front arm

FRONT ARM INSTALLATION

Installation is reverse of removal procedure.

Respect the following tightening torque specification:

DESCRIPTION	TIGHTENING TORQUE
Stopper strap(s) nuts	11 N•m (97 lbf•in)

REAR ARM/PIVOT ARM REMOVAL

NOTE: Rear arm can be removed with suspension assembly in place.

For rear arm removal, remove the following:

- shock upper bolt and nut
- throttle rods upper bolt and nut
- rear springs (refer to procedure above in this section)
- screws and washers holding rear arm to pivot arm.

Remove rear arm.

For pivot arm removal, remove the following:

- bolt, nut and washers holding pivot arm to runners.

Remove pivot arm.

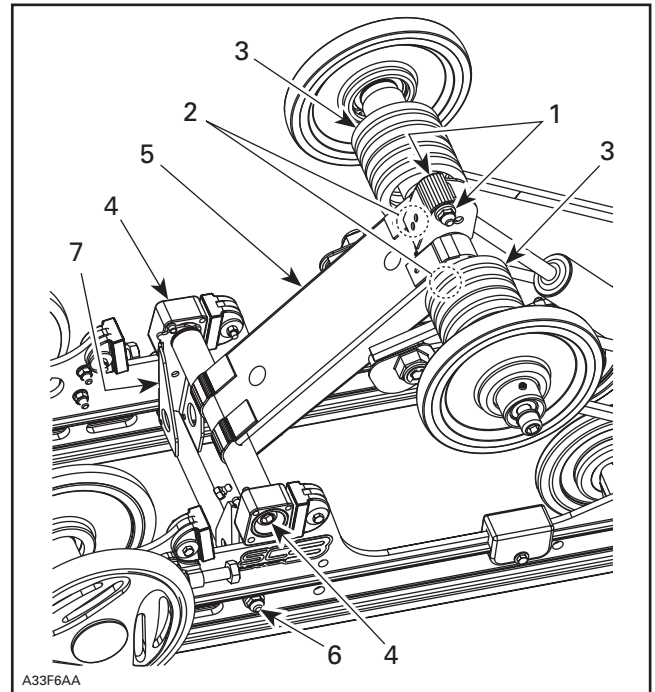

TYPICAL

1. Shock upper bolt and nut
2. Throttle rods upper bolt and nut
3. Rear springs
4. Rear arm/pivot arm screws and washers
5. Rear arm
6. Pivot arm/runners bolt, nut and washers
7. Pivot arm

REAR ARM/PIVOT ARM INSTALLATION

Installation is reverse of removal procedure. Pay attention to the following details.

Both blocks are identified R or L (right or left), see second following photo. At installation, make sure to install proper block on proper side.

Also, note that protrusion must be positioned above stoppers.

Section 09 REAR SUSPENSION

Subsection 02 (SC 3 SUSPENSION)

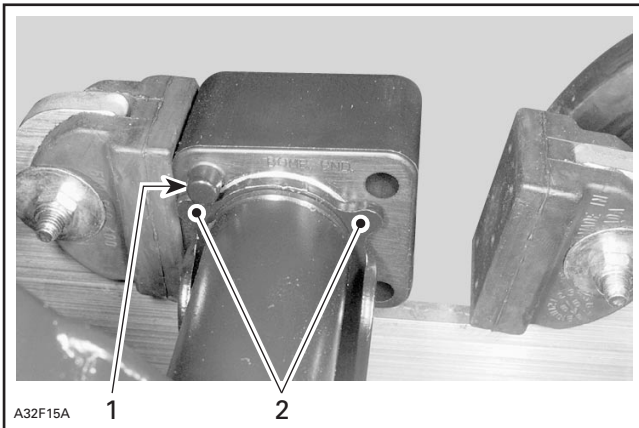

1. Protrusion
2. Stoppers

Dowel pin must exceed block guide by 2 to 2.3 mm (.079 to .091 in).

At installation, insert dowel pin into pivot arm hole.

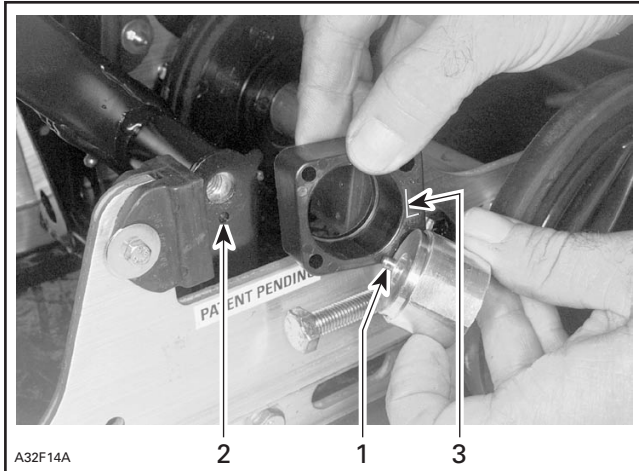

LEFT SIDE SHOWN

1. Dowel pin
2. Pivot arm hole
3. «L» identification for left side

Respect the following tightening torque specifications:

DESCRIPTION	TIGHTENING TORQUE
Locking ring set screw	2.5 N•m (22 lbf•in)
Pivot arm lower nut	24.5 N•m (18 lbf•ft)

STOPPER STRAP

Inspect strap for wear or cracks, bolt and nut for tightness. If loose, inspect hole for deformation. Replace as required.

Make sure it is attached through proper hole from the end.

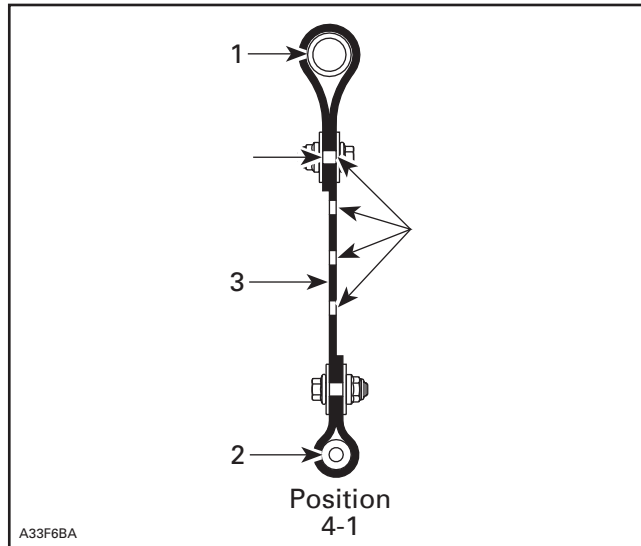

1. Front arm (top)
2. Front axle
3. Rear of vehicle

Respect the following tightening torque specification:

DESCRIPTION	TIGHTENING TORQUE
Stopper strap nuts	11 N•m (97 lbf•in)

RIDE ADJUSTMENT

Refer to the appropriate *Operator's Guide*.

LUBRICATION

Lubricate front and rear arms at grease fittings using suspension synthetic grease (P/N 293 550 033).

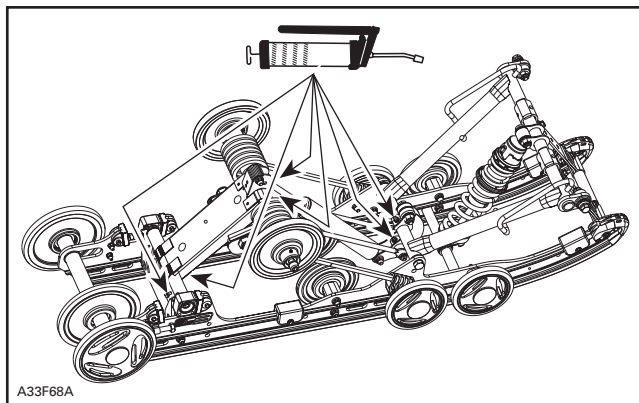

TYPICAL

Section 09 REAR SUSPENSION
Subsection 02 (SC 3 SUSPENSION)

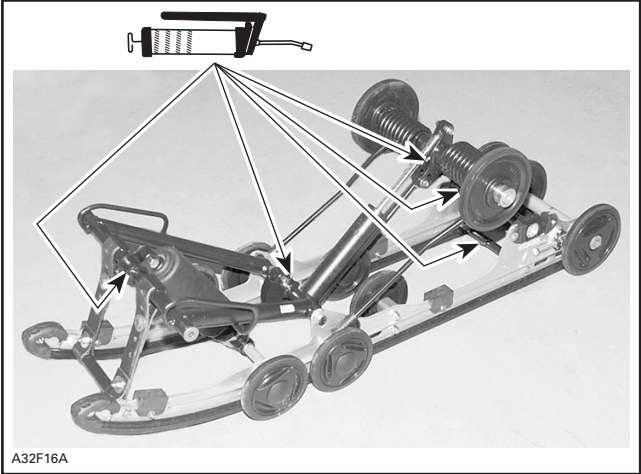

TYPICAL

SC 4 SUSPENSION

SERVICE PRODUCTS

Description	Part Number	Page
suspension synthetic grease	293 550 033	421

Section 09 REAR SUSPENSION

Subsection 03 (SC 4 SUSPENSION)

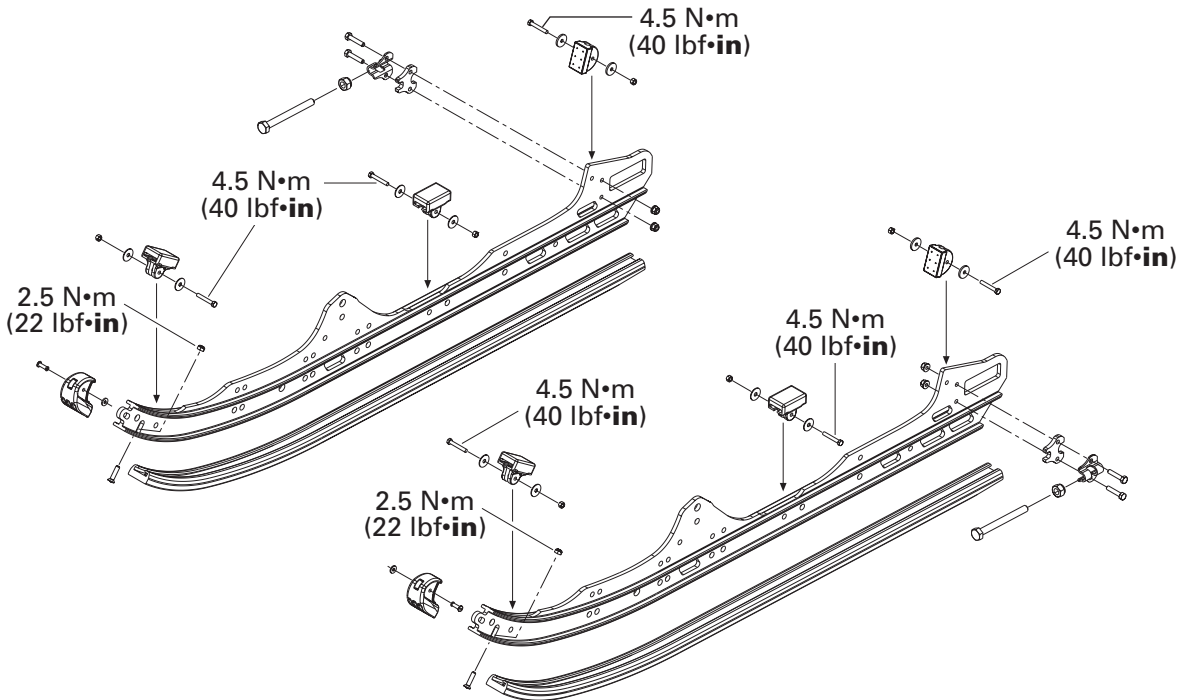
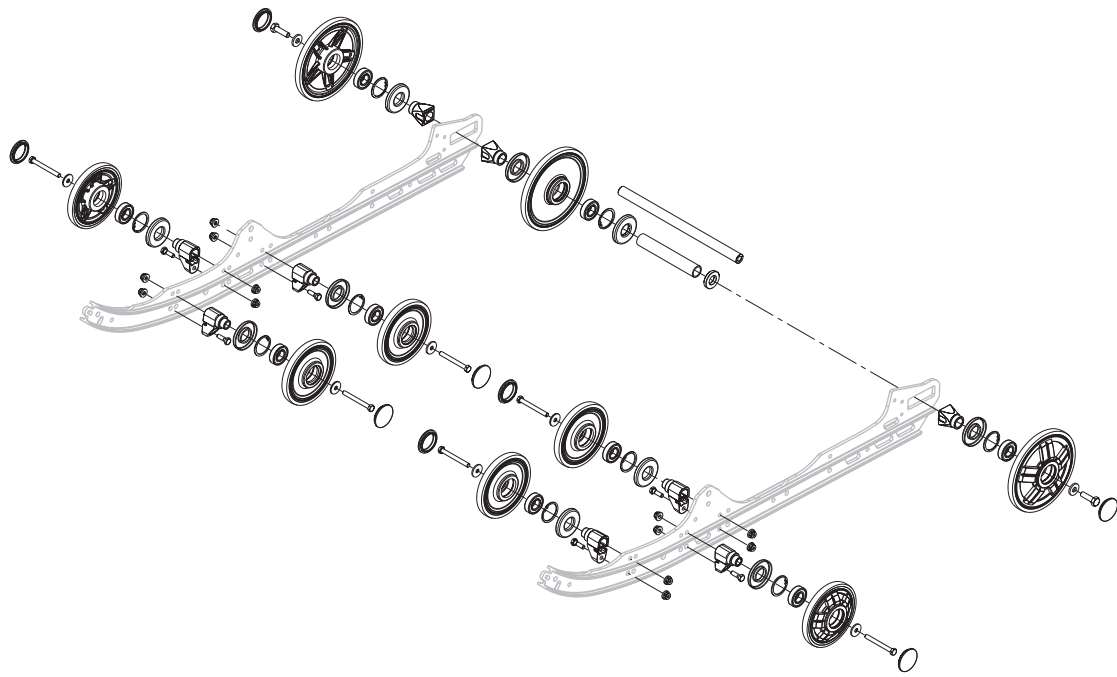

A33F61S

RAILS AND IDLER WHEELS

Section 09 REAR SUSPENSION
Subsection 03 (SC 4 SUSPENSION)

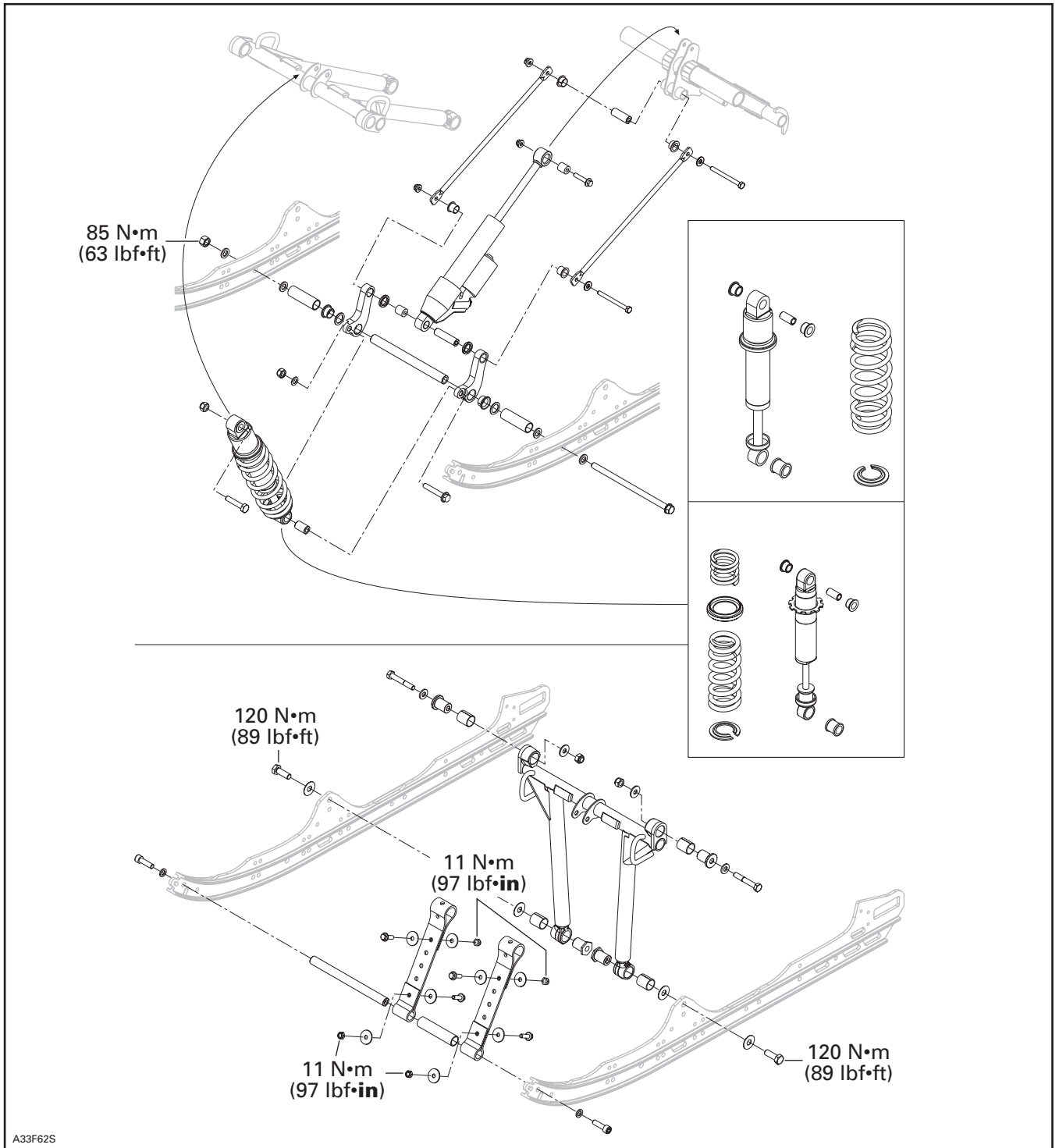

A33F62S

ARMS AND SHOCK ABSORBERS

Section 09 REAR SUSPENSION
Subsection 03 (SC 4 SUSPENSION)

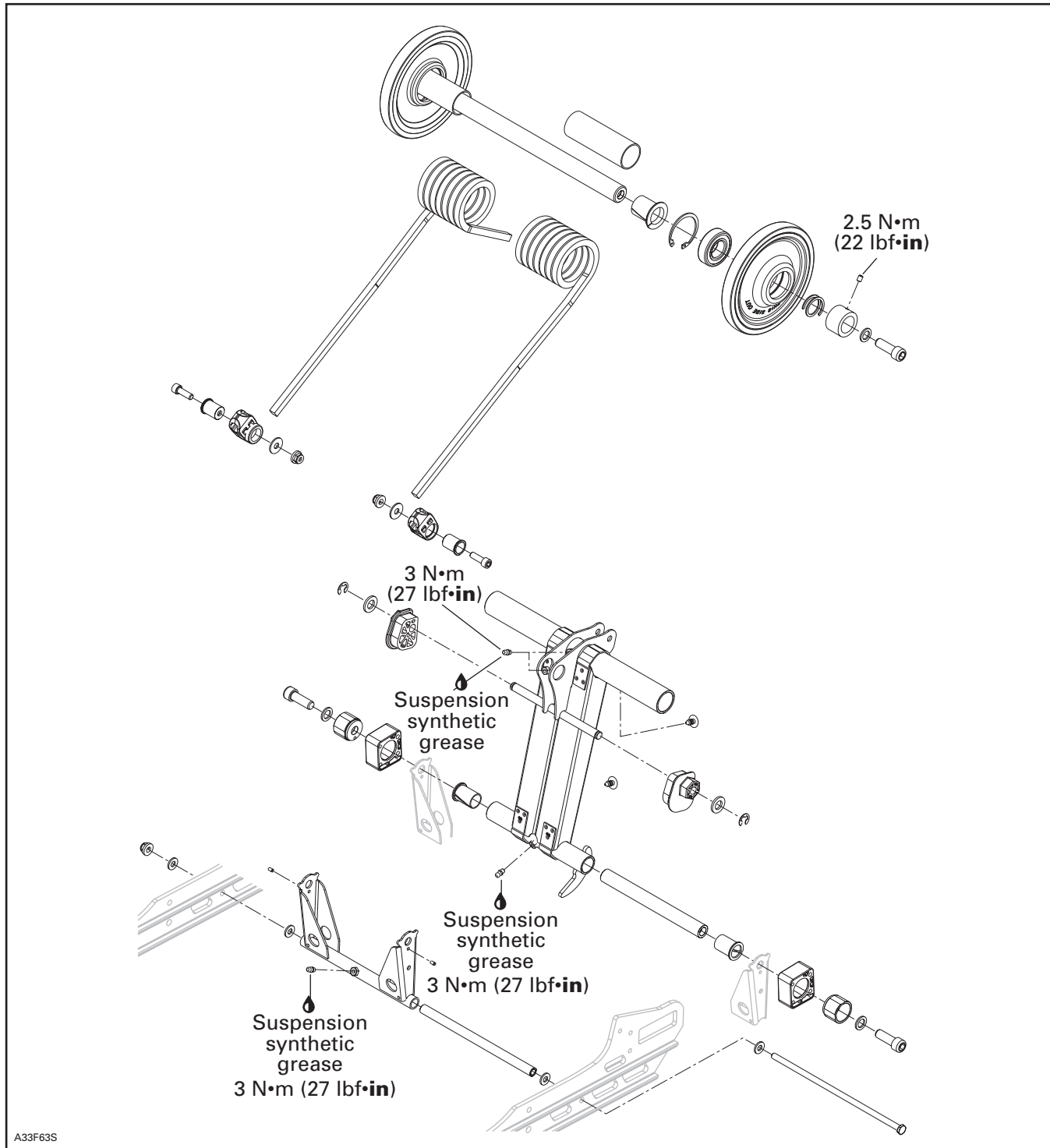

REAR ARM, SPRINGS AND IDLER WHEELS

AXLE SELF-LOCKING SCREW REMOVAL

CAUTION: These self-locking screws must always be replaced by new ones everytime they are removed.

NOTE: To prevent an axle from turning when unscrewing self-locking screws, proceed as follows:

- Remove one self-locking screw then install a 10 mm shorter non-self-locking one in place. Torque as specified in exploded view.
- Remove the opposite self-locking screw.
- Remove the temporary installed non-self-locking screw.
- If it doesn't work, heat bolt head to melt threadlocker.

REAR AXLE REMOVAL

Lift rear of vehicle and support it off the ground.
Remove screws on rear axle.
Completely loosen track tension.

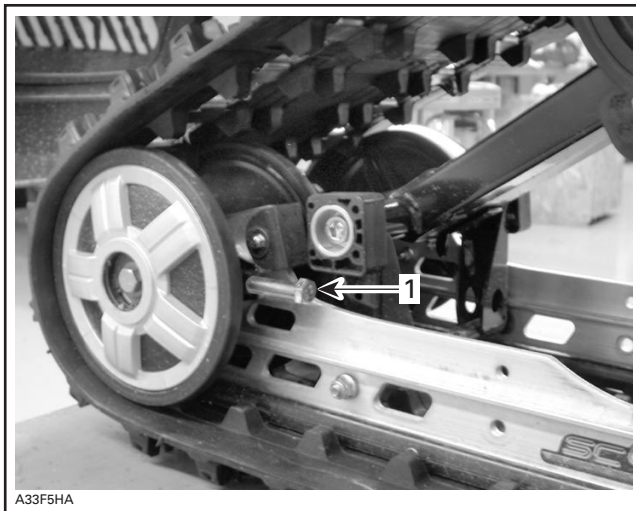

1. Completely loosen track tension

Remove the following:

- rear idler wheels
- idler wheels bearing protector
- idler wheels spacer.

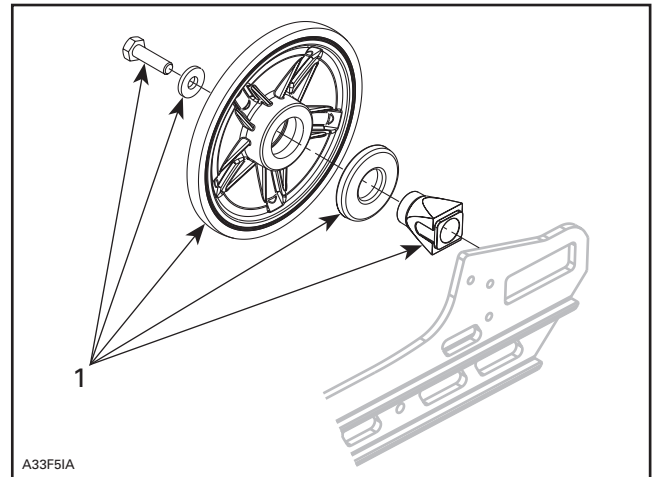

- ON BOTH SIDES**
1. Remove the following

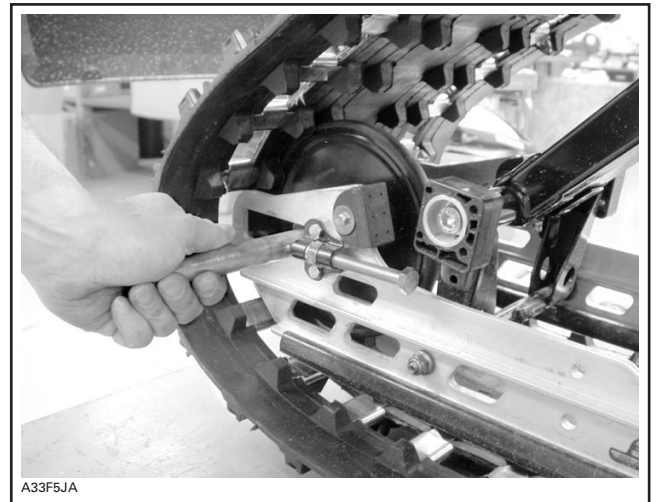

PULL OUT REAR AXLE

REAR AXLE INSTALLATION

Installation is reverse of removal procedure.

REAR SHOCK ABSORBER REMOVAL

Lift rear of vehicle and support it off the ground.
NOTE: If necessary, to ease shock removal, unfasten one end of stopper straps to release shock pressure.

Remove bolts and nuts from shock.

NOTE: If necessary, remove idler wheel(s) to ease lower shock component removal.

Section 09 REAR SUSPENSION

Subsection 03 (SC 4 SUSPENSION)

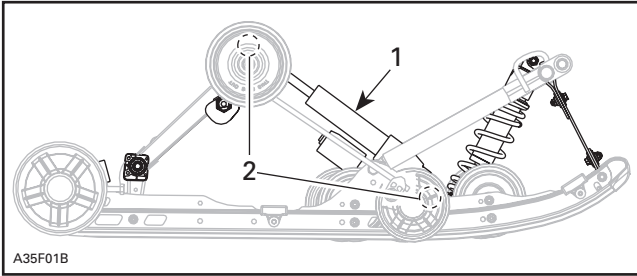

1. Rear shock absorber
2. Remove bolts and nuts

Using a punch, remove lower shock bar axle.
Pay attention to plastic spacers.
Remove shock.

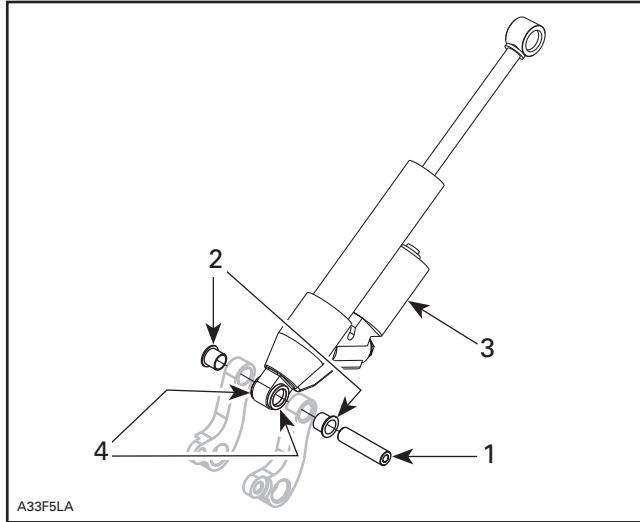

1. Bar axle
2. Swivel bushings
3. Shock reservoir position
4. Plastic spacers

FRONT SHOCK ABSORBER REMOVAL

Lift rear of vehicle and support it off the ground.
Unfasten one end of stopper straps.



1. Unfasten one end of stopper straps

Remove bolts and nuts from shock.

NOTE: If necessary, remove idler wheel(s) to ease lower shock component removal.

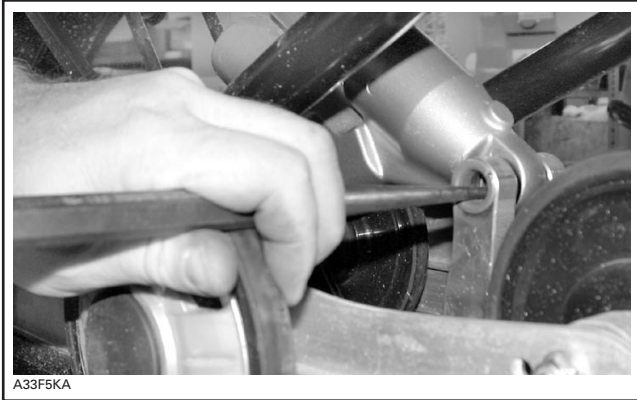

REMOVE BAR AXLE

REAR SHOCK ABSORBER INSTALLATION

Installation is reverse of removal procedure. Pay attention to the following details.

To ease shock installation, secure upper shock first.

CAUTION: Make sure shock bar axle is aligned with swivel bushings before inserting it.

CAUTION: Shock reservoir must be towards track.

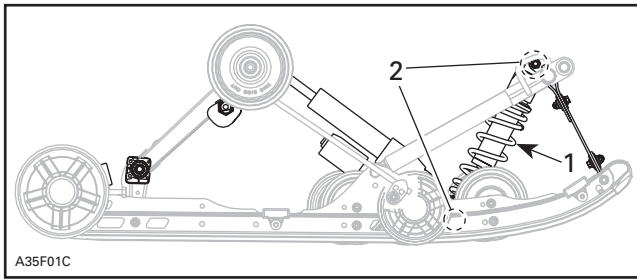

1. Front shock absorber
2. Remove bolts and nuts

FRONT SHOCK ABSORBER INSTALLATION

Installation is reverse of removal procedure. Pay attention to the following details.

Shock absorber nuts should be on the RH side.

Install shock adjustment ring towards the top and valve towards tunnel, see photo.

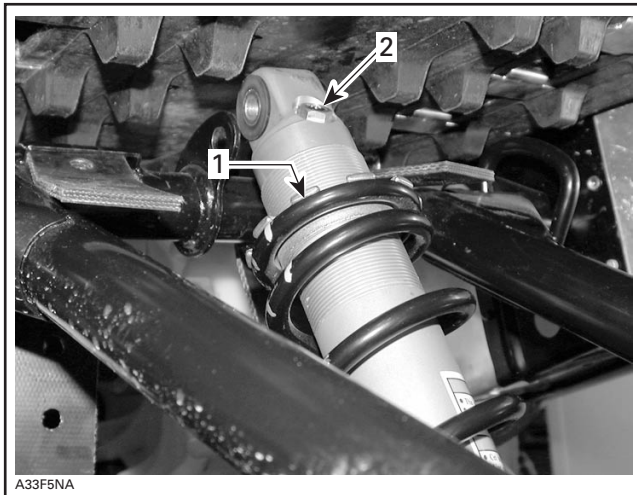

1. Adjustment ring
2. Valve

REAR SPRING REMOVAL

Lift rear of vehicle and support it off the ground. Decrease spring preload by turning cams accordingly.

Loosen rear arm top axle from chassis.

Remove idler wheels to have access to spring support screws.

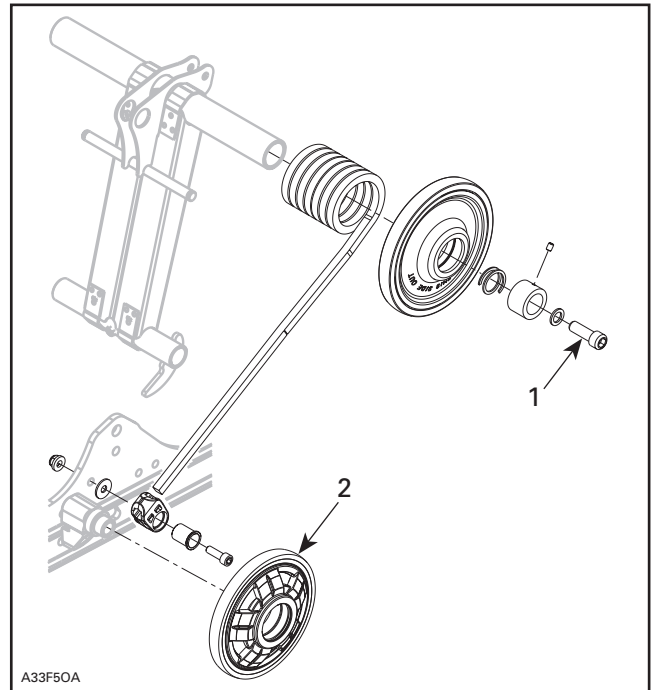

1. Loosen rear arm top axle from chassis
2. Remove idler wheels

Remove spring supports.

⚠ WARNING
Supports are spring loaded.



REMOVE SPRING SUPPORTS

Remove screws and washers from rear arm top axle.

Section 09 REAR SUSPENSION

Subsection 03 (SC 4 SUSPENSION)

Loosen set screw from locking rings.
Remove the following on both sides:

- locking ring
- axle spring
- top idler wheel
- rear spring.

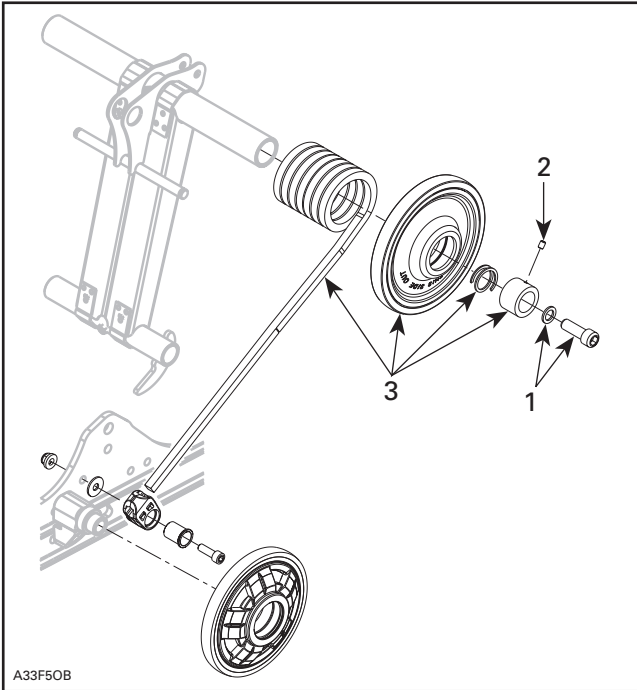

ON BOTH SIDES
1. Remove screws
2. Loosen set screw
3. Remove the following

REAR SPRING INSTALLATION

Installation is reverse of removal procedure. Pay attention to the following details.

At assembly, respect THIS SIDE OUT inscription on top idler wheels.

At assembly, make sure that spring end is in cam adjuster.

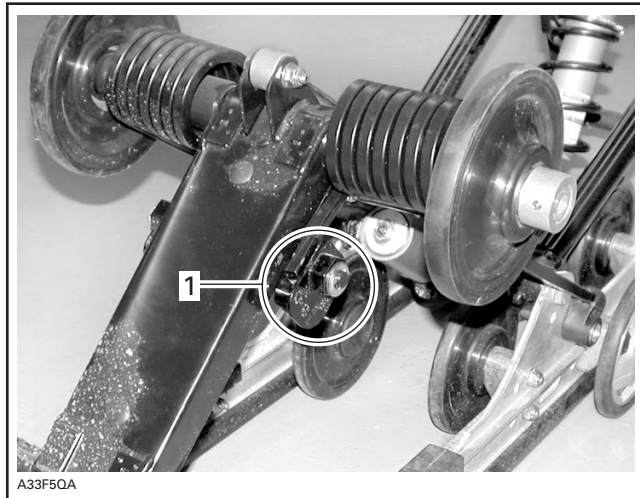

ON BOTH SIDES
1. Spring end in cam adjuster

CAUTION: To avoid track damage, spring supports must be mounted upward.

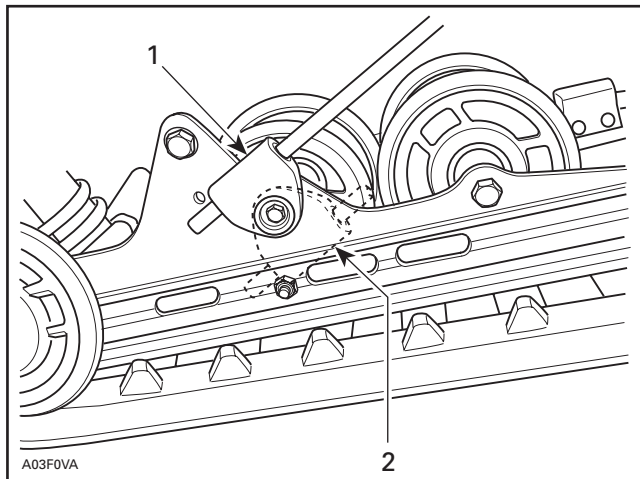

TYPICAL — RIGHT SIDE SHOWN
1. Right position: upward
2. Wrong position

Respect the following tightening torque specification:

DESCRIPTION	TIGHTENING TORQUE
Locking ring set screw	2.5 N•m (22 lbf•in)

SLIDER SHOE VERIFICATION

Molding line is the wear limit indicator.

Section 09 REAR SUSPENSION

Subsection 03 (SC 4 SUSPENSION)

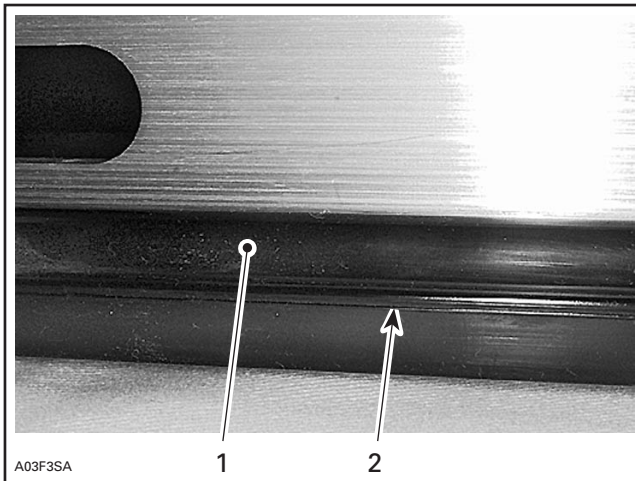

TYPICAL

1. Slider shoe
2. Molding line (wear limit indicator)

Replace slider shoes when wear limit is reached.

CAUTION: Slider shoes must always be replaced in pairs.

SLIDER SHOE REMOVAL

Lift rear of vehicle and support it off the ground.

Completely loosen track tension.

Remove nut and screw of each runner.



REMOVE NUT AND SCREW OF EACH RUNNER

Align track window with slider shoe.

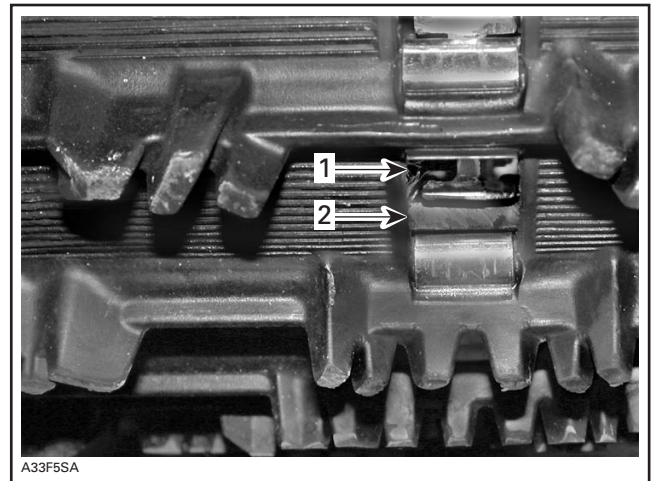

TYPICAL

1. Track window
2. Slider shoe

Using a pry bar or screw driver, push slider shoe until it comes in contact with track.

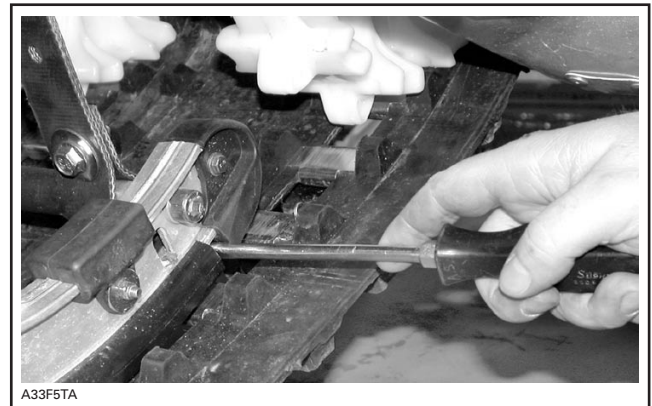

PUSH ON SLIDER SHOE

Using locking pliers, pull slider shoe thru track window to remove.

NOTE: If necessary, lubricate track window to facilitate slider shoe removal.

Section 09 REAR SUSPENSION

Subsection 03 (SC 4 SUSPENSION)



A33F5UA

PULL ON SLIDER SHOE TO REMOVE



A33F5VA

1. Enough clearance

SLIDER SHOE INSTALLATION

Installation is reverse of removal procedure. Pay attention to the following details.

Make sure to insert slider shoe end with hole first. Respect the following tightening torque specification:

DESCRIPTION	TIGHTENING TORQUE
Slider shoe nut	2.5 N•m (22 lbf•in)

SUSPENSION REMOVAL

Lift rear of vehicle and support it off the ground.

Completely loosen track tension.

Remove rear arm top axle screws.

Remove front arm top bolts.

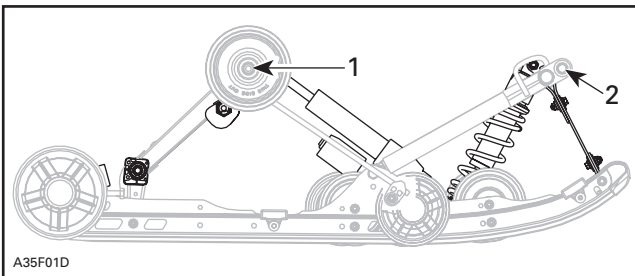

A35F01D

1. Remove rear arm top axle screws
2. Remove front arm top bolts

Lift rear of vehicle until front arm has enough clearance to pass underneath tunnel.

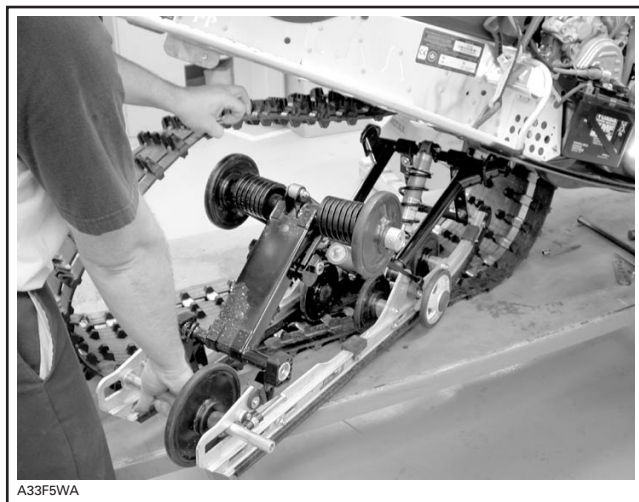

A33F5WA

REMOVE SUSPENSION

SUSPENSION INSTALLATION

Installation is reverse of removal procedure. Pay attention to the following details.

Inspect track thoroughly before reinstalling suspension. Refer to TRACK.

Install suspension into track with front portion first.

Adjust track tension.

FRONT ARM REMOVAL

NOTE: Front arm can be removed with suspension assembly in place.

Section 09 REAR SUSPENSION

Subsection 03 (SC 4 SUSPENSION)

Lift rear of vehicle and support it off the ground.

Remove the following:

- shock upper bolt and nut
- front idler wheels
- spring supports (to gain access to front arm lower bolts)

⚠ WARNING

Supports are spring loaded.

- front arm lower bolts and washers
- unfasten one end of stopper straps
- remove front arm upper bolts, nuts and washers.

Remove front arm.

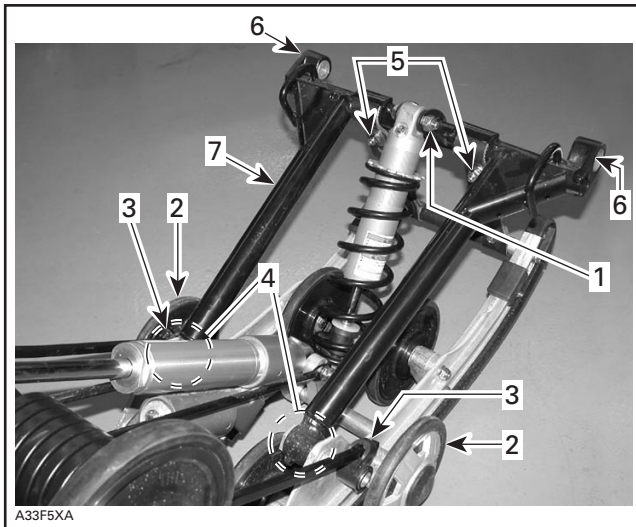

SUSPENSION REMOVED FOR CLARITY

1. Shock upper bolt and nut
2. Front idler wheels
3. Spring supports
4. Front arm lower bolts and washers
5. Unfasten one end of stopper straps
6. Front arm upper bolts, nuts and washers
7. Front arm

FRONT ARM INSTALLATION

Installation is reverse of removal procedure. Pay attention to the following details.

To properly hold front arm axles when applying tightening torque to front arm lower bolts, it may be necessary to remove idle wheels.

Respect the following tightening torque specifications.

DESCRIPTION	TIGHTENING TORQUE
Stopper straps nuts	11 N•m (97 lbf•in)
Front arm lower bolts	120 N•m (89 lbf•ft)

REAR ARM/PIVOT ARM REMOVAL

NOTE: Rear arm can be removed with suspension assembly in place.

For rear arm removal, remove the following:

- shock upper bolt and nut
- rear springs (refer to procedure above in this section)
- screws and washers holding rear arm to pivot arm.

For pivot arm removal, remove the following:

- bolts, nuts and washers holding pivot arm to runners.

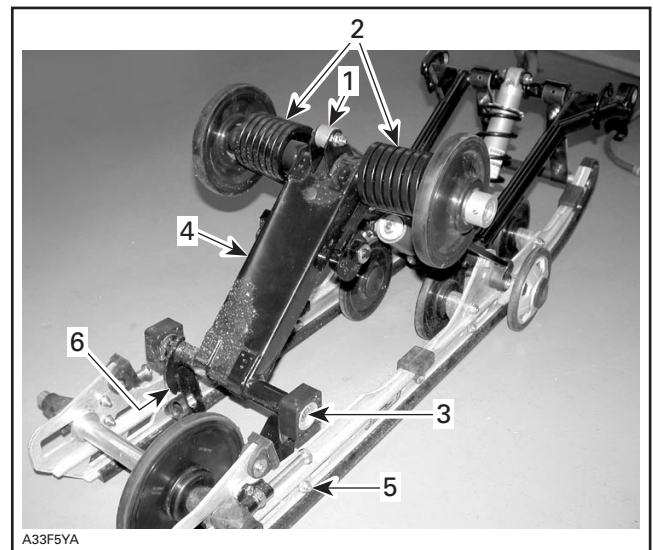

SUSPENSION REMOVED FOR CLARITY

1. Shock upper bolt and nut
2. rear springs
3. Rear arm/pivot arm screws and washers
4. Rear arm
5. Pivot arm/runner bolts, nuts and washers
6. Pivot arm

REAR ARM/PIVOT ARM INSTALLATION

Installation is reverse of removal procedure. Pay attention to the following details.

Pivot arm grease fitting must be towards the front of the vehicle.

Section 09 REAR SUSPENSION

Subsection 03 (SC 4 SUSPENSION)

At installation, rear arm stroke limiter must be on rear side.

Insert dowel pin into pivot arm hole, dowel pin must exceed block guide by 2 to 2.3 mm (.079 to .091 in).

Respect the following tightening torque specifications.

DESCRIPTION	TIGHTENING TORQUE
Pivot arm/runners nut	25 N•m (18 lbf•ft)
Locking ring set screw	2.5 N•m (22 lbf•in)

BLOCK INSTALLATION

Both blocks are identified R or L (right or left) and have position number (from 1 to 4). At installation make sure to install proper block on proper side with the same adjustment position on both sides.

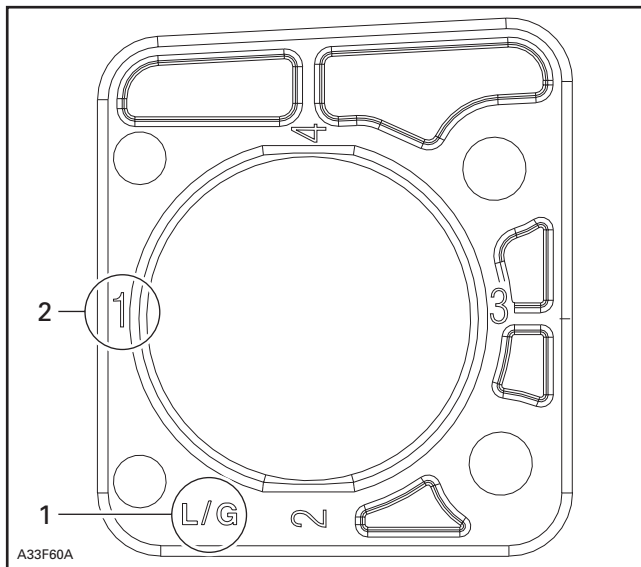

TYPICAL

1. Blocks are identified R or L (right or left)
2. Blocks position number (from 1 to 4)

IDLER WHEELS INSTALLATION

Refer to illustration for idler wheels position at installation.

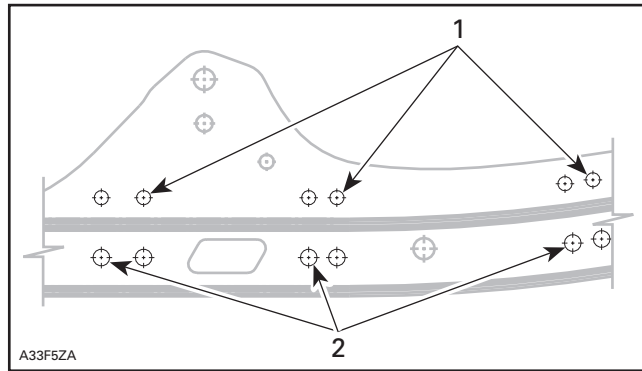

1. RH side wheels position
2. LH side wheels position

STOPPER STRAP

Inspect strap for wear or cracks, bolt and nut for tightness. If loose, inspect hole for deformation. Replace as required.

Make sure it is attached through proper hole from the end.

Torque nut to 11 N•m (97 lbf•in).

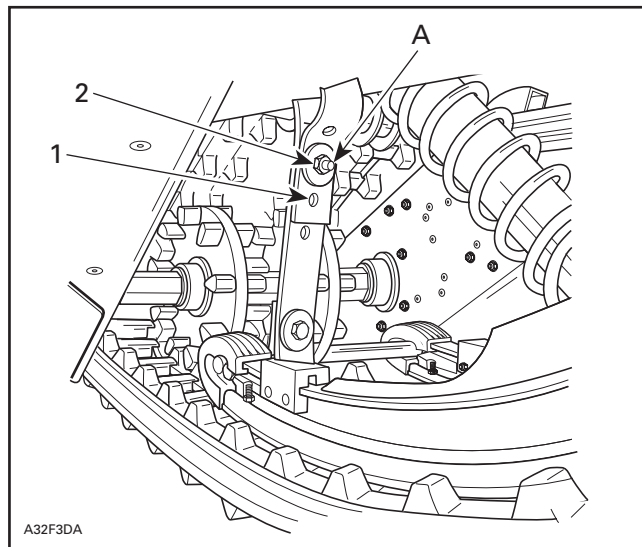

TYPICAL

1. 1st hole
2. 2nd hole

A. 11 N•m (97 lbf•in)

RIDE ADJUSTMENT

Refer to the appropriate *Operator's Guide*.

LUBRICATION

Lubricate pivot arm and rear arm at grease fittings using suspension synthetic grease (P/N 293 550 033).

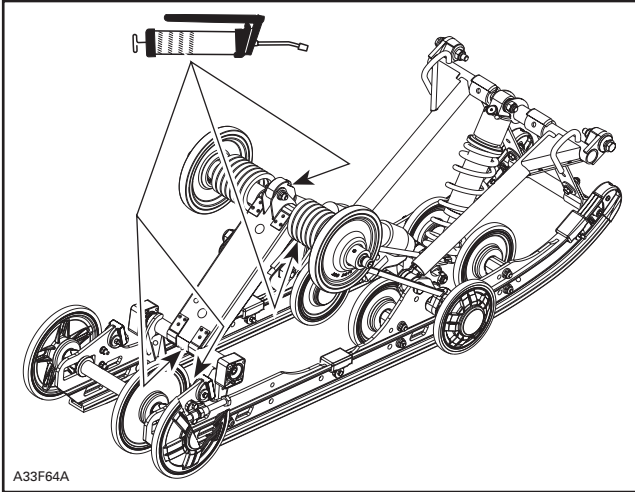

SHOCK ABSORBER INSPECTION AND SERVICING

SERVICE TOOLS

Description	Part Number	Page
floating piston remover tool.....	529 035 907	426
gas fill tool kit (needle type).....	503 190 102	425, 431-432
gas shock valve tool (tire valve type).....	529 035 570	431
HPG shock holding tool	529 035 769	425
shock spring remover	529 035 504	423
shock wrench	529 035 727	425

SERVICE PRODUCTS

Description	Part Number	Page
Bombardier HPG shock oil.....	293 600 035	429
Loctite 271.....	293 800 005	427
Molykote G-n paste	711 297 433	429

SPRING REMOVAL

Remove shock absorber from vehicle. Refer to the appropriate subsection.

Use shock spring remover (P/N 529 035 504) and put it in a vise. Mount shock in it and turn shock so that a spring coil rests against spring compressor jaw.

Close and lock bar. Place handle horizontally by changing position of clevis pin.

Push down on handle until it locks. Remove spring stopper and cap then release handle.

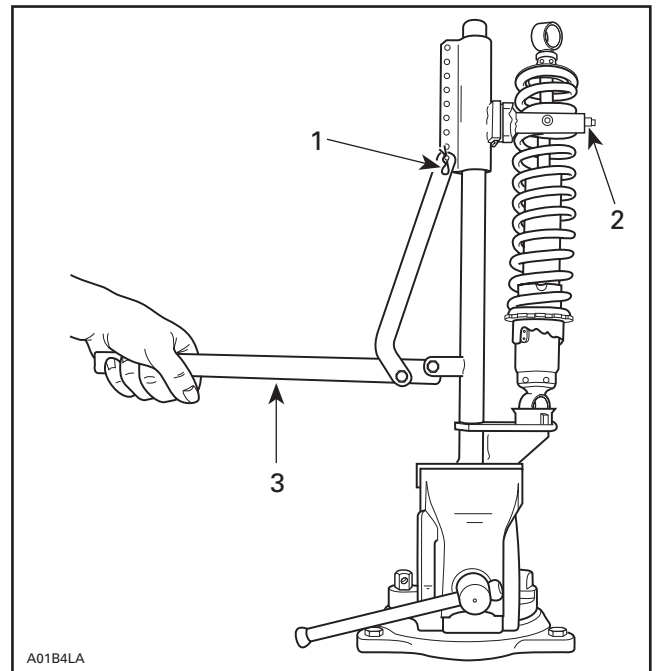

1. Clevis pin
2. Bar
3. Handle placed horizontally

Section 09 REAR SUSPENSION

Subsection 04 (SHOCK ABSORBER INSPECTION AND SERVICING)

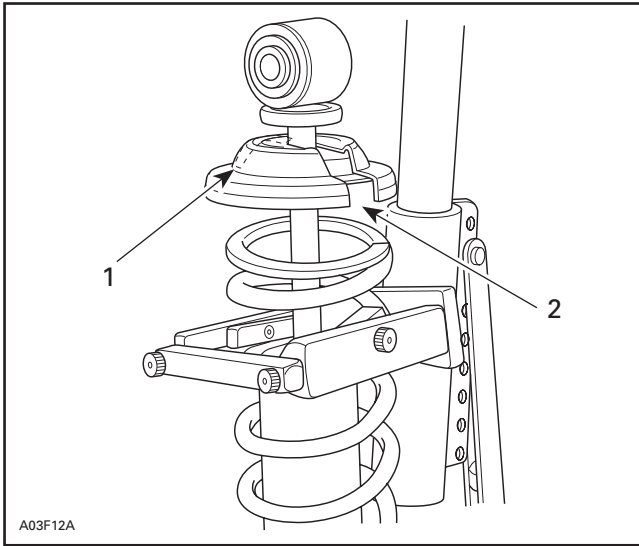

1. Cap opening
2. Spring stopper opening

Remove stopper.

Remove tool and spring from shock absorber.

SHOCK ABSORBER INSPECTION

Hydraulic Shock

Secure the shock body end in a vise with its rod upward.

CAUTION: Do not clamp directly on shock body.

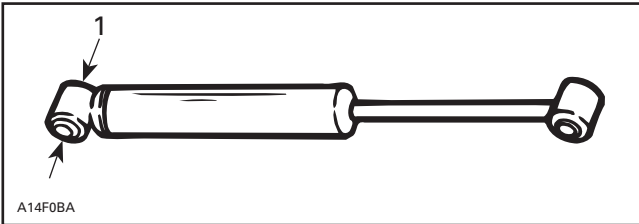

1. Clamp

Examine each shock for leaks. Extend and compress the piston several times over its entire stroke. Check that it moves smoothly and with uniform resistance with its rod upward.

After at least 5 complete strokes, pay attention to the following conditions that will denote a defective shock:

- A skip or a hang back when reversing stroke at mid travel.
- Seizing or binding condition except at extreme end of either stroke.
- Oil leakage.

- A gurgling noise, after completing one full compression and extension stroke.

Renew if any faults are present.

Gas Shock Except Variable Rate

Because of gas pressure, strong resistance is felt when compressing shock.

For the verification of stroke, or if suspecting an internal leak between oil chamber and gas chamber, check shock as follows:

Install shock in a vise clamping on its bottom eyelet with its rod upward. Verify the stroke compression when the rod is fully extended.

Let it stand for 5 minutes.

Completely push down the shock rod then release.

The shock should extend unassisted. Rod must come out at a steady speed. If speed suddenly increases particularly at end of extension, replace shock.

Variable Rate Gas Shock

Because of gas pressure, strong resistance is felt when compressing shock.

For the verification of stroke, or if suspecting an internal leak between oil chamber and gas chamber, check shock as follows:

Install shock in a vise clamping on its bottom eyelet with its rod upward. Verify the stroke compression when the rod is fully extended.

Let it stand for 5 minutes.

Push down the shock rod. The feeling will be stiff for around first 25 mm (1 in), soft up to 25 to 50 mm (1 to 2 in) and stiff after that. This stiff, soft and stiff phenomenon shows the normal operation of shock.

When released, the shock should extend unassisted. The rod speed coming out will go slow - faster and slow again due to the VR zone.

All Gas Shock

If suspecting a frozen shock proceed as follows:

Place shock in a freezer (temperature below 0°C (32°F)) for 4 hours.

Push down on rod and note its resistance. If shock is frozen it will be much more difficult to compress than for the new one.

Section 09 REAR SUSPENSION

Subsection 04 (SHOCK ABSORBER INSPECTION AND SERVICING)

DISASSEMBLY AND ASSEMBLY

High Pressure Gas Take Apart Shock (HPG T/A)

There are two types of high pressure gas take apart (HPG T/A) shock. One type has a tire valve and the other has a needle valve.

SHOCK TYPE	INFLATION TOOL
Tire valve type	529 035 570
Needle valve type	503 190 102

HPG T/A shocks come in two sizes. C-36 shock is 36 mm (1.417 in) in diameter and C-46 shock is 46 mm (1.811 in).

SHOCK SIZE	SERVICING TOOL	(P/N)
C-36	Piston guide	529 026 600
	Seal guide	529 026 500
	Shock wrench	529 035 727
C-46	Piston guide	529 035 608
	Seal guide	529 035 728
	Shock wrench	529 035 727

Release nitrogen (N) pressure on any HPG T/A shock with internal floating piston (IFP).

WARNING

Nitrogen gas is under extreme pressure. Use caution when releasing this gas volume. Protective eye wear should be used.

Mount shock in a vise with HPG shock holding tool (P/N 529 035 769).

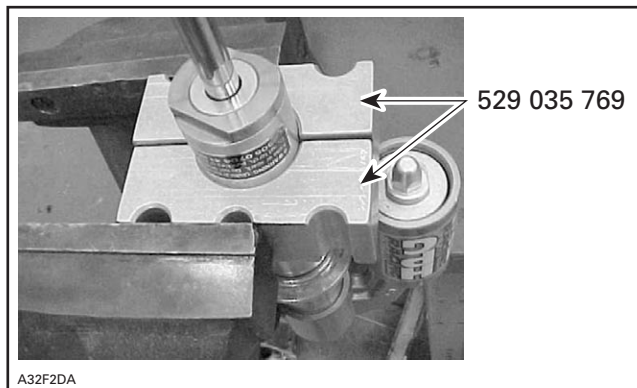

Remove screw on top of valve. Place the needle guide of gas fill tool kit (needle type) (P/N 503 190 102) on the shock valve. Press the detent pin and push forward the needle assembly very slowly towards rubber of needle valve. Push on shock tool valve center rod to release gas pressure.



Remove tool from shock.

Screw Cap Type HPG T/A Shock

Using appropriate size of shock wrench (P/N 529 035 727) unscrew seal carrier.



TYPICAL

Snap Ring Cap Type HPG T/A Shock

Using a flat tool, pop-out the cap.

Section 09 REAR SUSPENSION

Subsection 04 (SHOCK ABSORBER INSPECTION AND SERVICING)

Compress the carrier to access and remove the snap ring.

All HPG T/A Shocks

With the seal carrier removed, slowly lift and remove damper rod assembly from the damper body.

NOTE: Remove damper rod assembly slowly to reduce oil spillage and prevent piston seal damage by damper body threads. Wrap the damper body with a shop cloth to capture possible overflow oil while removing the damper piston.

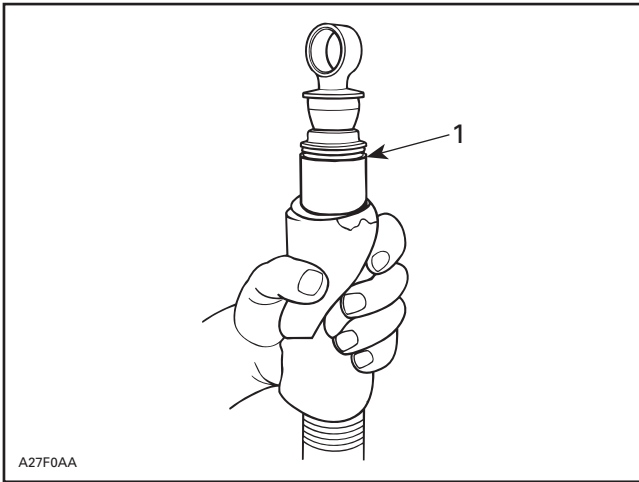

1. Oil flows

Discard old oil into storage container. Never reuse damper oil during shock rebuild.

HPG T/A Shocks Except with External Reservoir

Remove valve core. Using compressed air pressure, carefully remove floating piston from damper body. Hold shop cloth over damper body opening to catch released floating piston. Allow room for floating piston to leave damper body.

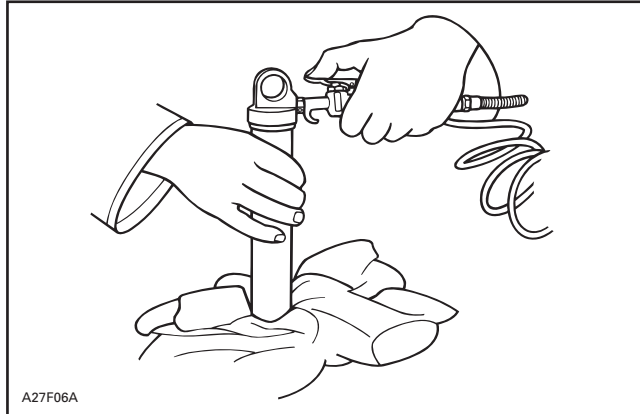

A27F06A

TYPICAL

HPG T/A Shocks with External Reservoir

Install floating piston remover tool (P/N 529 035 907) on shock absorber, as shown below.



A32F3YA

1. Floating piston remover tool (P/N 529 035 907)

Place shock absorber in a position where external gas reservoir opened extremity is blocked. Refer to following photo.

Section 09 REAR SUSPENSION
Subsection 04 (SHOCK ABSORBER INSPECTION AND SERVICING)

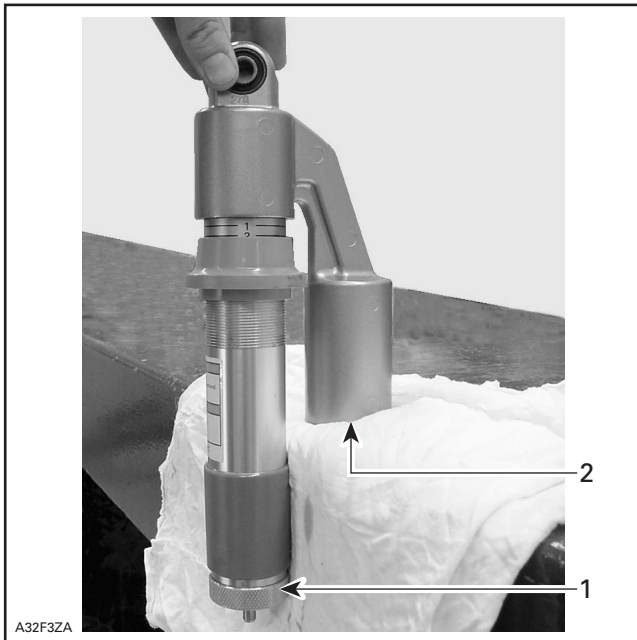

1. Tool
2. Reservoir opened extremity blocked by leaning on work bench

With a low pressure hand pump, pressurize shock absorber until external reservoir piston pops-out.

NOTE: Use towels to prevent damaging external reservoir piston when it pops-out.

⚠ WARNING

Whenever using compressed air, use an O.S.H.A. approved air gun and wear protective eye wear.

Thoroughly clean, with a typical cleaning solution, and blow dry using low pressure air. Carefully inspect the damper body for any imperfections or signs of wear in the damper bore.

Replace damper body if wear is identified.

All HPG T/A Shocks

Holding the damper rod assembly in a bench vise, begin piston and valve removal.

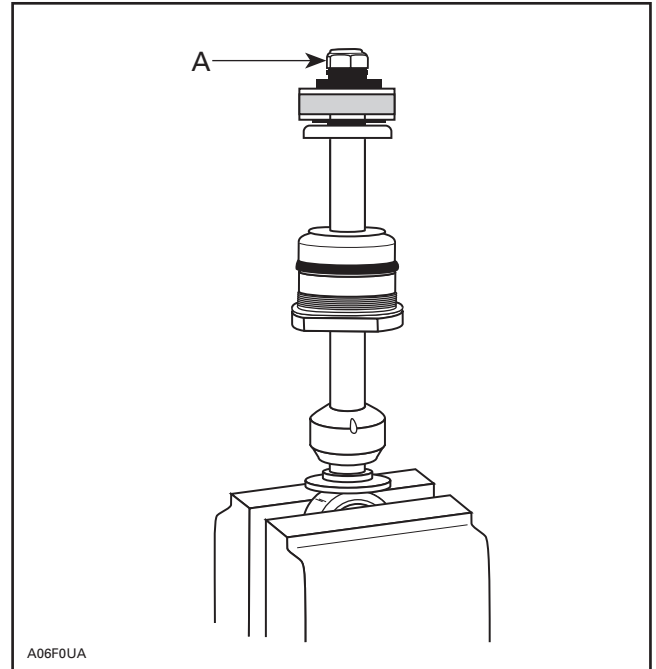

A. Remove damper nut

Always arrange parts removed in the sequence of disassembly.

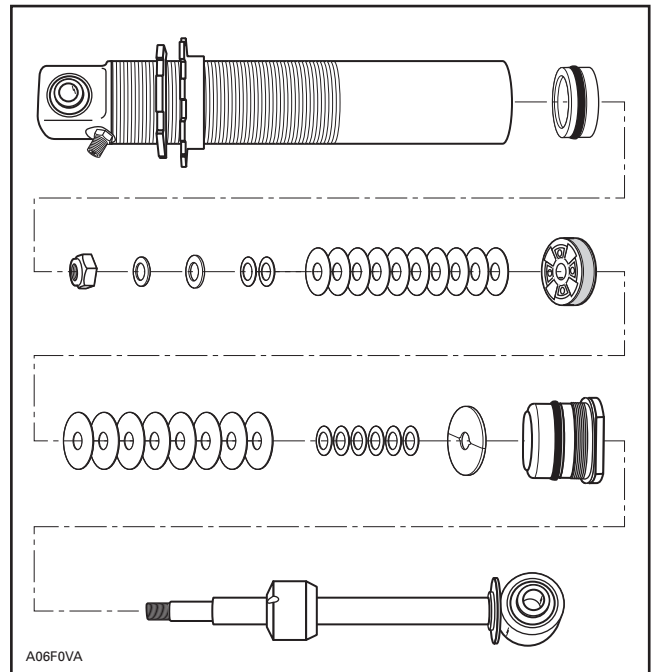

NOTE: As a general rule we suggest replacing the damper rod lock-nut after 4 rebuilds to ensure good locking friction and use Loctite 271 (P/N 293 800 005) each time.

Section 09 REAR SUSPENSION

Subsection 04 (SHOCK ABSORBER INSPECTION AND SERVICING)

NOTE: If revalving is to be done, it is imperative that you identify the original shim pack (size and number of shims). There is no need to remove seal carrier if only revalving is to be done.

Shims can be measured by using a vernier caliper or a micrometer.

NOTE: All shims should be carefully inspected and any bent or broken shims must be replaced for the shock to function properly.

After the new or replacement shim pack has been selected, reassemble in the reverse order of disassembly. Torque piston nut to 27 - 29 N•m (20 - 21 lbf•ft).

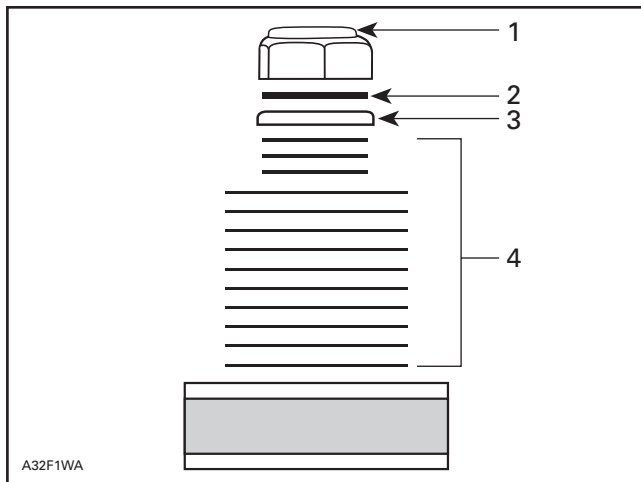

1. Damper nut
2. Spacer
3. Stopper with its round edge facing nut
4. Shim pack

CAUTION: The damper rod nut can only be reused 4 times, then, must be replaced. Do not substitute this part for non - O.E.M. use Loctite 271 on nut each time.

This (these) spacer washer(s) must be used as shown to ensure damper rod nut does not bottom out or contact shaft threads.

Rebound valve stopper with round edge facing nut.

NOTE: Rebound shim stack must not reach into threads of damper shaft. Spacer under damper shaft nut is used to prevent damper shaft nut from bottoming on threads.

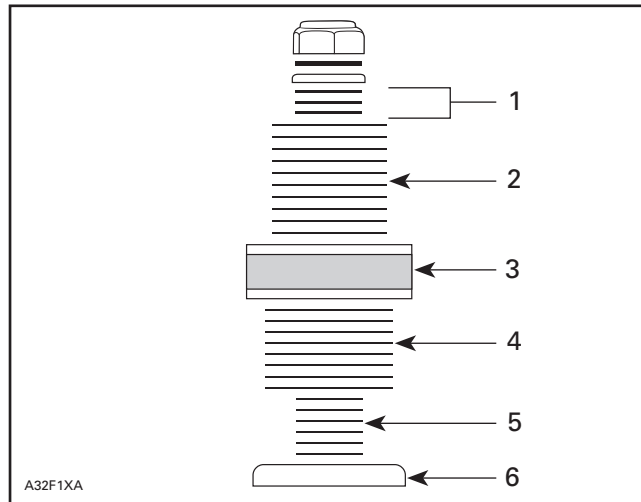

1. Rebound dampening shim pack
2. Rebound dampening shim pack
3. Piston
4. Compression dampening shim pack
5. Compression dampening shim pack
6. Stopper

If the seal carrier assembly is replaced, use seal pilot to guide seal over damper shaft. Lubricate seal carrier guide pilot before use.

CAUTION: Failure to use seal pilot will result in seal damage.

Reassemble damper rod assembly, taking care to properly assemble shim packs as required for your dampening needs. Ensure that the shaft piston is installed with the slits/larger intake holes facing the rebound shim stack.

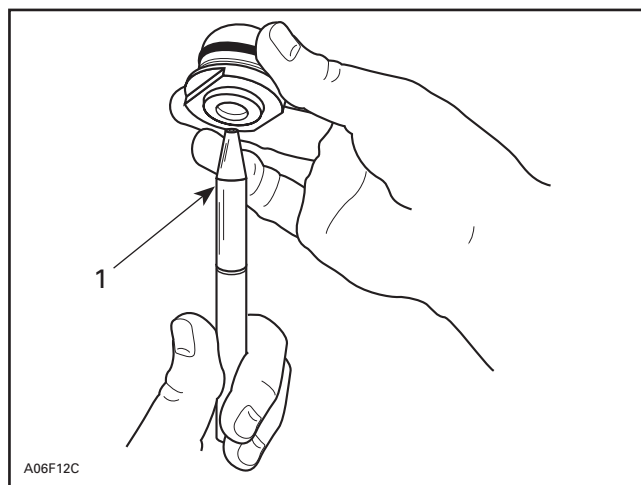

1. Seal guide

Section 09 REAR SUSPENSION

Subsection 04 (SHOCK ABSORBER INSPECTION AND SERVICING)

If floating piston has been removed, reinstall floating piston into damper body (ensure that valve core has been removed). Use Molykote G-n paste (P/N 711 297 433) to ease O-ring past damper body threads with floating piston guide.

CAUTION: Failure to install IFP correctly could result in shock damage.

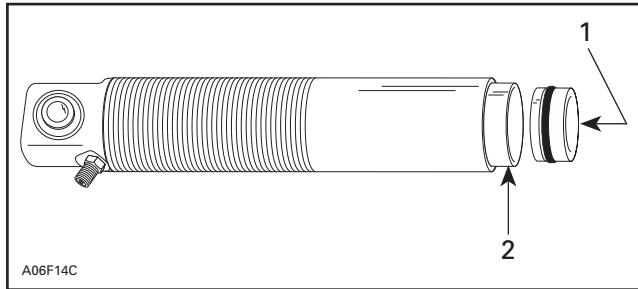

1. Push (slowly) by hand
2. Floating piston guide

NOTE: Lubricate inside of piston guide with Molykote G-n paste (P/N 711 297 433).

Install floating piston to the proper depth refer to following the table.

On all HPG take apart shocks, the floating piston is installed hollow side up.

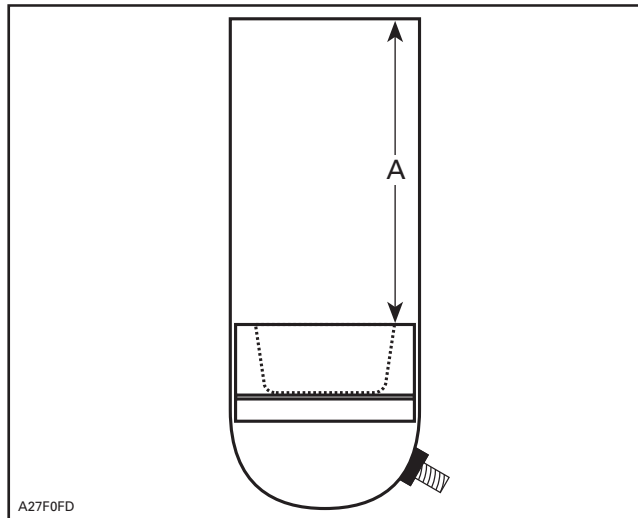

A. Installation distance for floating piston installation

SHOCK P/N	INSTALLATION DISTANCE OF FLOATING PISTON MM
503 190 306	54.5
503 190 987	54.5
503 190 445	119.5
503 190 655	119.5
503 190 747	119.5
503 190 973	119.5
503 191 043	119.5
503 190 975	121.5
503 190 980	168
503 190 808	171.5
503 190 978	171.5
503 190 994	171.5
503 190 382	178.5
503 190 449	188

NOTE: If the floating piston is installed too far into the damper body, light air pressure through valve (with core removed) will move piston outward.

NOTE: Reinstall tire valve core after IFP has been installed at correct height and before adding oil.

⚠ WARNING

Whenever using compressed air exercise extreme caution, cover damper opening with shop cloth to reduce chance of possible injury.

CAUTION: Moisture laden compressed air will contaminate the gas chamber and rust floating piston.

⚠ WARNING

Always wear protective eye wear whenever using compressed air.

Fill the shock with Bombardier HPG shock oil (P/N 293 600 035) to approximately 10 mm (.393 in), from the base of seal carrier threads.

Section 09 REAR SUSPENSION

Subsection 04 (SHOCK ABSORBER INSPECTION AND SERVICING)

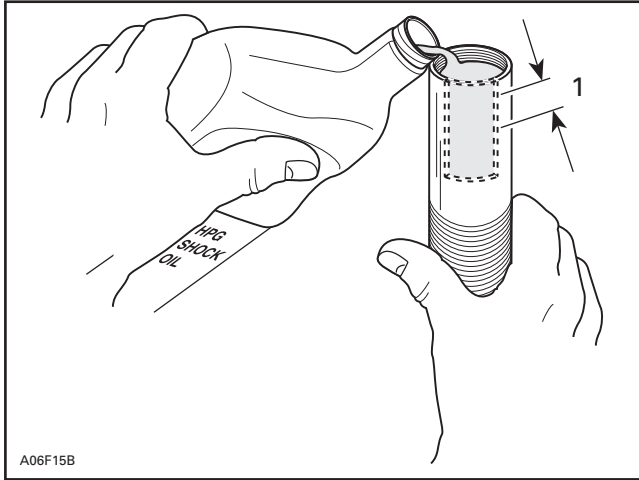

1. Fill to 10 mm (.393 in)

NOTE: Although we do not measure the exact amount of oil added to the damper, approximately 252 mL (8.52 oz. U.S.) will be used.

Carefully insert damper rod into the damper body. Lightly oil damper piston seal ring with shock oil to ease installation.

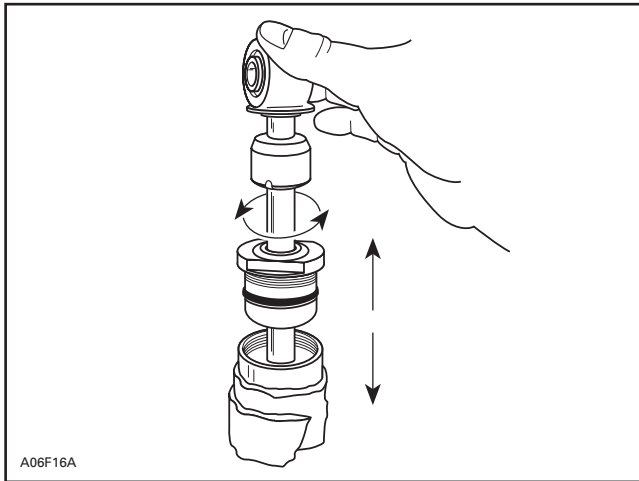

NOTE: Some shock oil will overflow when installing damper. Wrap damper with shop cloth to catch possible overflow oil.

CAUTION: Use care when passing piston into damper body at damper body threads.

Slight oscillation of damper rod may be required to allow piston to enter damper body bore.

Slowly push piston into damper body. Slight up and down movement may be required on short stroke to allow all air to pass through piston assembly. The gentle tapping of a small wrench, on the shock eye, may help dislodge air trapped in the submerged piston. Be careful not to drive the shaft any deeper into the oil than is necessary to just cover the shim stack.

NOTE: Fast installation of the damper rod may displace the floating piston from its original position. This must not occur if the damper is expected to perform as designed.

With damper rod piston into oil, TOP OFF damper oil volume. Oil level should be to damper body thread base.

Screw Cap Type HPG T/A Shock

Seal carrier assembly can now be threaded into damper body. This should be done slowly to allow weepage of oil and to minimize IFP displacement. Torque seal carrier to 90 to 100 N•m (66 to 74 lbf•ft).

Snap Ring Cap Type HPG T/A Shock

Seal carrier assembly can now be pushed into damper body to pass snap ring groove. Install snap ring into groove.

Tap the cap on the shock body.

All HPG T/A Shocks

After the seal carrier is fully in place avoid pushing the shaft into the body until the nitrogen charge is added.

Section 09 REAR SUSPENSION

Subsection 04 (SHOCK ABSORBER INSPECTION AND SERVICING)

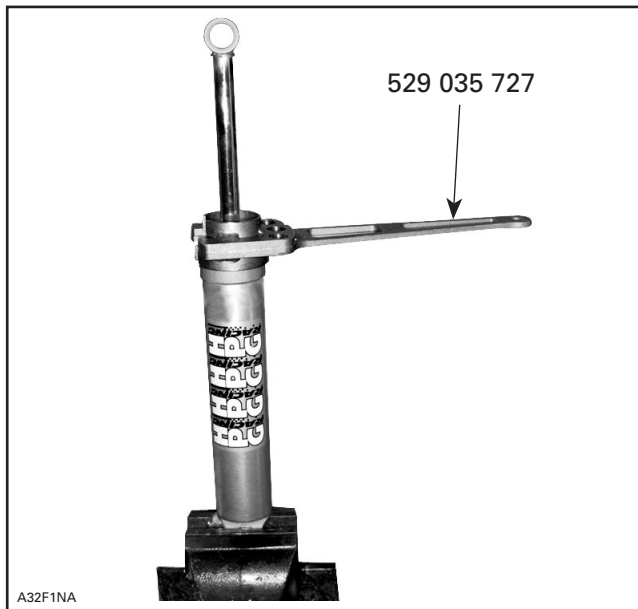

When removing and retightening the tire valve acorn nut use minimal torque. When the cap is over tightened and subsequently removed it may prematurely break the seal of the tire valve to the shock body and cause a loss of nitrogen charge without being noticed. If you suspect this has happened then recharge the shock as a precaution. Inspect the tire valve cap before installation to ensure that the internal rubber gasket is in its proper position.

Nitrogen (N) can now be added to damper body.

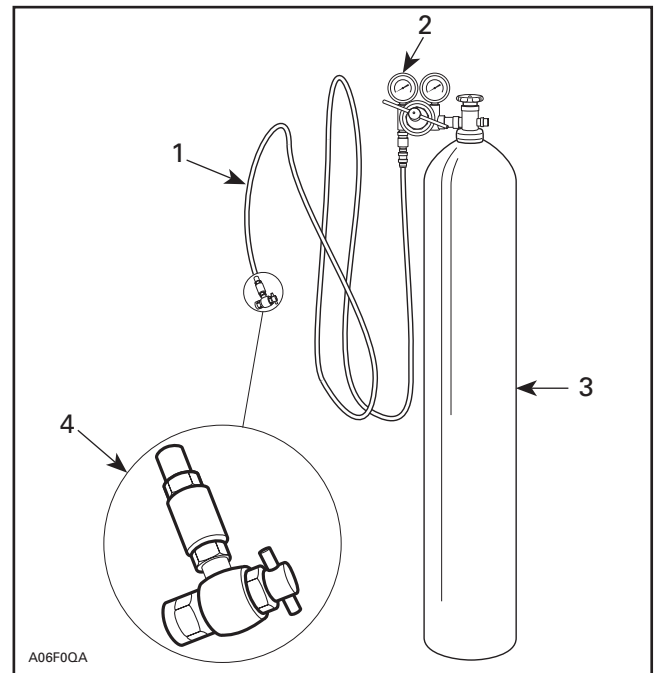

1. High pressure hose
2. Stage regulator, delivery pressure range 2070 kPa (300 PSI)
3. High pressure cylinder filled with industrial grade nitrogen
4. Valve tip (P/N 529 035 570) permanently installed

NOTE: Never substitute another gas for nitrogen. Nitrogen has been selected for its inert qualities and will not contaminate the gas chamber of the shock.

Preset your pressure regulator to 2070 kPa (300 PSI) nitrogen (N), this gas pressure will restore the correct pressure for your damper.

CAUTION: Do not exceed the recommended pressure values.

⚠ WARNING

Whenever working with high pressure gas, use eye wear protection. Never direct gas pressure toward anybody.

Install the gas fill tool kit (needle type) (P/N 503 190 102) on gas shock valve tool (tire valve type) (P/N 529 035 570). Set the regulator pressure on the nitrogen cylinder as per the shock requirement.

Section 09 REAR SUSPENSION

Subsection 04 (SHOCK ABSORBER INSPECTION AND SERVICING)

Mount the shock on vise. Remove screw on top of valve. Place the needle guide of gas refill tool on the shock valve. While depressing the detent pin of the gas refill tool and pushing forward the needle assembly, insert the needle through the rubber core of the pressure valve assembly of the shock.

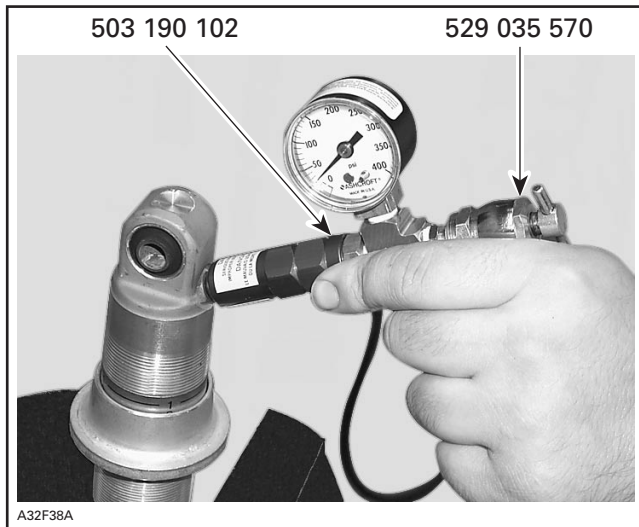

NOTE: For replacement of the needle or filling the shock, carefully follow the instructions provided with the gas fill tool kit (needle type) (P/N 503 190 102).

On some models, rubber may pop out of needle valve when inserting tool needle. If so, remove valve core and rubber then, reinstall rubber with its larger diameter last.

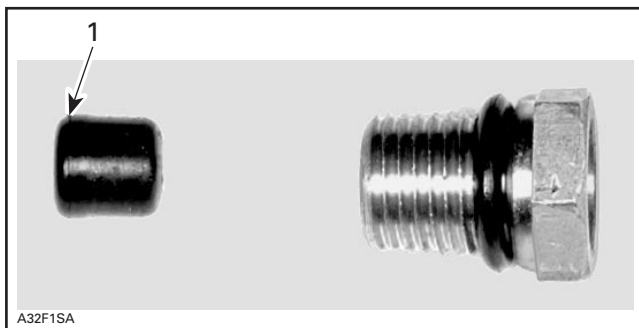

1. Larger diameter

When the shock is filled with gas, install back the screw on top of the valve.

NOTE: Carefully inspect damper for gas or oil leaks. Any leaks must be corrected before continuing.

Damper gas pressure cannot be confirmed by using a pressure gauge. The volume of gas in the shock is very small, and the amount lost during gauge installation will lower the pressure too much and require refilling.

After recharging is complete the rebuilt shock should be bench-tested. Stroke the shock to ensure full travel and smooth compression and rebound action. If the shaft moves in or out erratically this could indicate too much air is trapped inside. If the shaft will not move or has partial travel then it may be hydraulically locked. In either event the shock must be rebuilt again. Pay particular attention to the placement of the IFP, quantity of oil and shim stack/piston assembly.

STEERING SYSTEM

SERVICE PRODUCTS

<u>Description</u>	<u>Part Number</u>	<u>Page</u>
BOMBARDIER LUBE	293 600 016	446
suspension synthetic grease	293 550 033	446

Section 10 STEERING/FRONT SUSPENSION

Subsection 01 (STEERING SYSTEM)

Linkage Arrangement

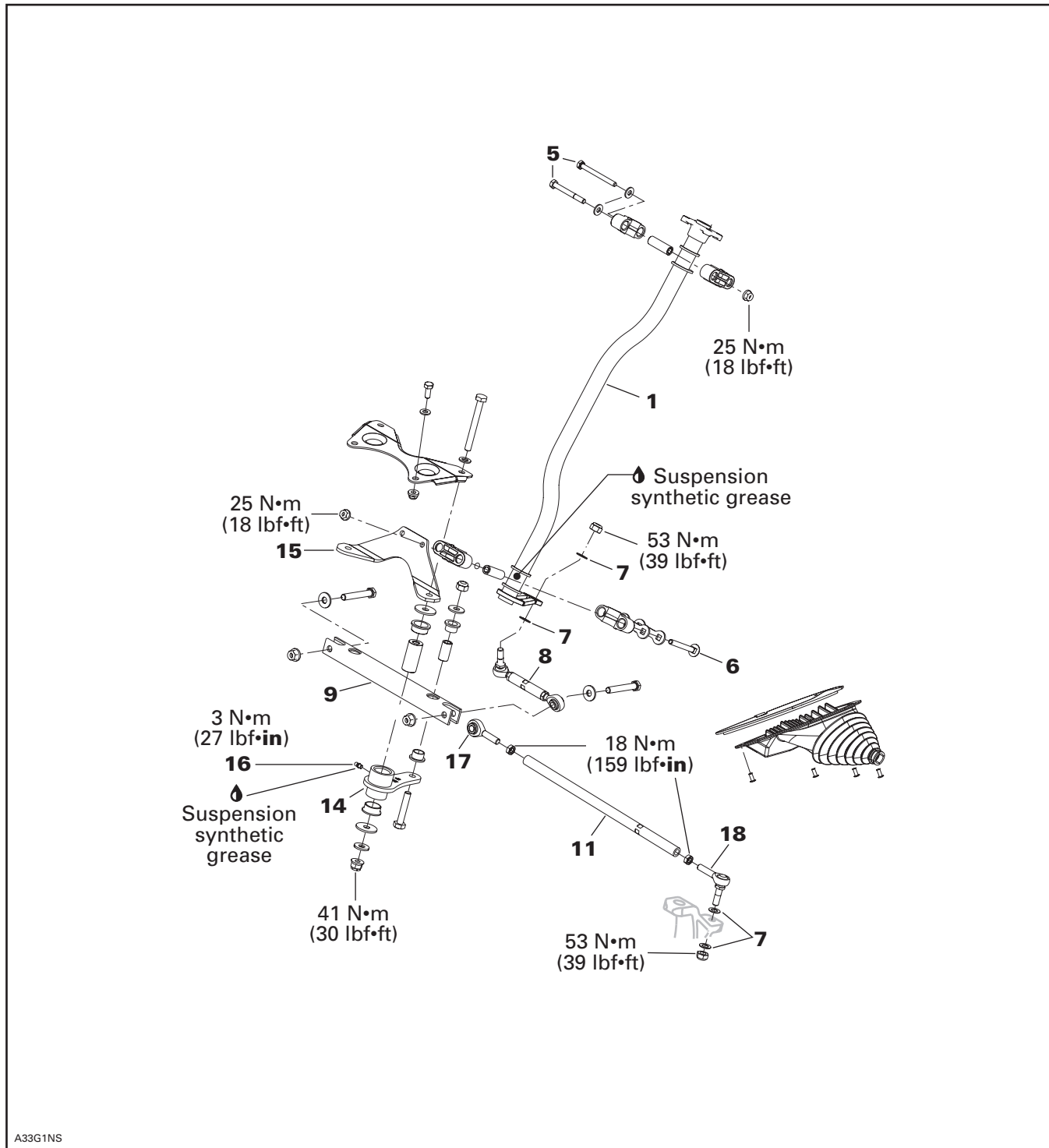

A33G1NS

Section 10 STEERING/FRONT SUSPENSION

Subsection 01 (STEERING SYSTEM)

DISASSEMBLY AND ASSEMBLY

Grip

NOTE: These models feature an integrated heating element in the plastic sleeve of the grip no. 13.

CAUTION: Removing grip from handlebar might damage the heating element. Do not remove needlessly.

NOTE: If heating grip does not work and needs to be replaced, the grip can be cut with a knife for removal.

Throttle Side:

Unfasten windshield (if necessary).

NOTE: Throttle lever housing no. 21 must come off handlebar along with grip.

Remove cap no. 3 or steering padding no. 23 according to model. Unplug RH harness on top of steering column. Cut locking ties retaining RH harness to handlebar.

Remove throttle lever housing cover no. 19.

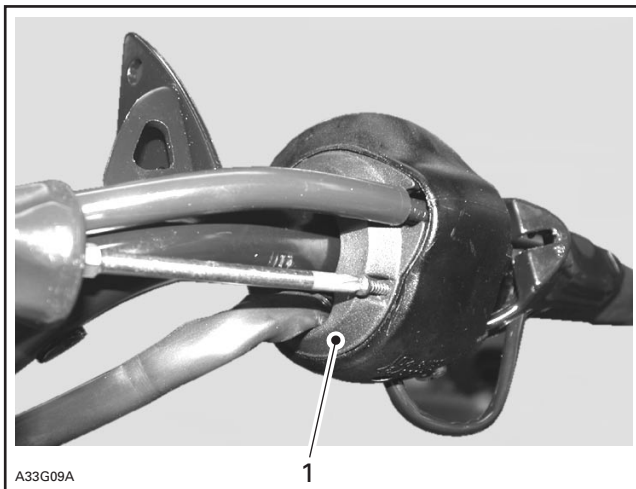

1. Throttle lever housing cover

Remove circlip no. 24 from throttle cable housing. Unfasten throttle cable from throttle lever, then pull out throttle cable housing from throttle lever housing no. 21.

Unscrew screws no. 10 and remove J-hook no. 12 from end of grip on so equipped models.

Loosen screw no. 20 retaining throttle lever housing to handlebar. See photo below.

Insert the open side of a 23 mm (7/8 in) wrench against the inner end of grip.

CAUTION: Pay attention not to damage wires with the wrench.

Using a plastic hammer, tap on the side of the wrench end to make the grip slide out.

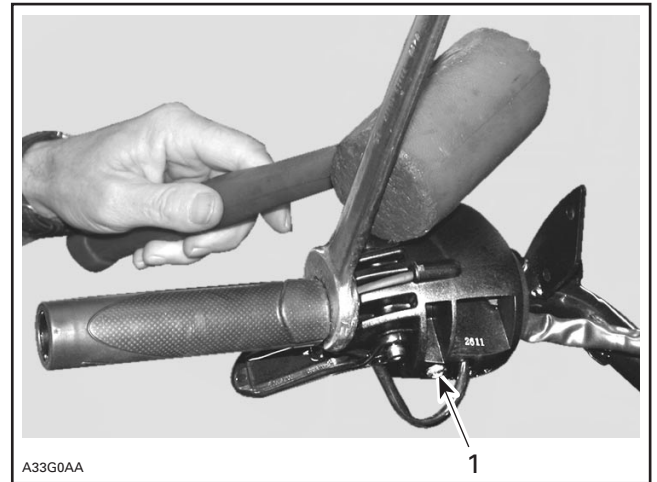

1. Screw retaining throttle lever housing

Cut locking ties on harness. Using the multilock-terminal housing extraction tool AMP (P/N 755430-2), push the 3 wires of the heating grip harness out of connector housing. Note the position of the wires for reinstallation.

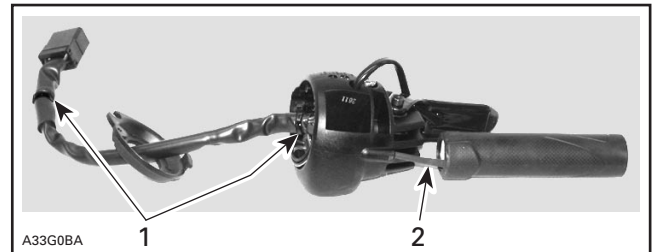

1. Locking ties
2. Heating grip harness

Pull heating grip harness out of throttle lever housing.

For installation refer to GRIP INSTALLATION below.

Brake Side:

Unclip windshield.

Unplug connectors from brake light switch located on master cylinder no. 22.

Section 10 STEERING/FRONT SUSPENSION

Subsection 01 (STEERING SYSTEM)

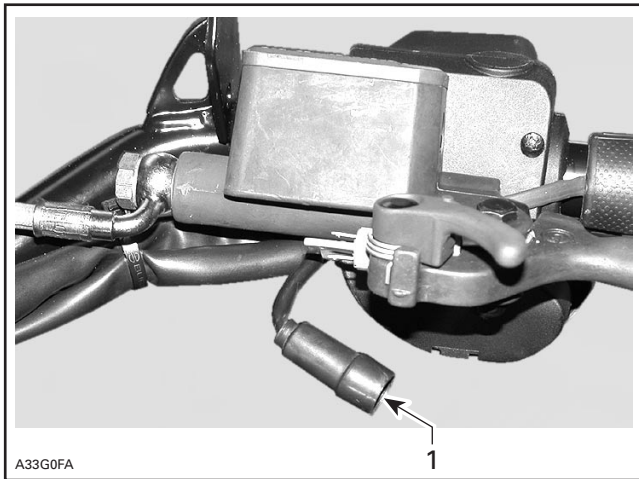

1. Connectors unplugged

Unplug LH harness on top of steering column. Cut locking ties retaining brake light switch/heating grip harness to handlebar.

Using the multilock-terminal housing extraction tool AMP (P/N 755430-2), push the 3 wires of the heating grip harness out of connector housing. Note the position of the wires for reinstallation.

Pull heating grip wires out of brake light switch/heating grip harness.

Insert the open side of a 23 mm (7/8 in) wrench against the inner end of grip.

CAUTION: Pay attention not to damage wires with the wrench.

Using a plastic hammer, tap on the side of the wrench end to make the grip sliding out.

Grip Installation:

Installation is the opposite procedure of the removal but pay attention to the following.

Clean handlebar ends and inside of heating grip with isopropyl alcohol. Let dry before installation.

WARNING

Handlebar end and inside of heating grip must be clean and dry before installing heating grip to ensure proper adhesion.

Position grip on handlebar with its harness aligned with windshield bracket. See next photo.

Use the appropriate insertion tool to properly install grip.

MODEL	TOOL PART NUMBER
Models with straight grips	529 035 897
Models with J-hooks	529 035 936

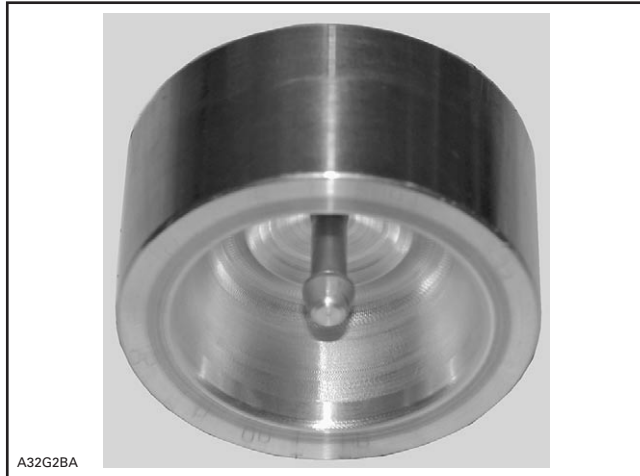

CAUTION: Installing grip without the insertion tool is likely to damage its heating element.

Position the insertion tool at the outside end of grip.

Using a plastic hammer, tap on tool to push grip on. Continue to tap until grip bottoms.

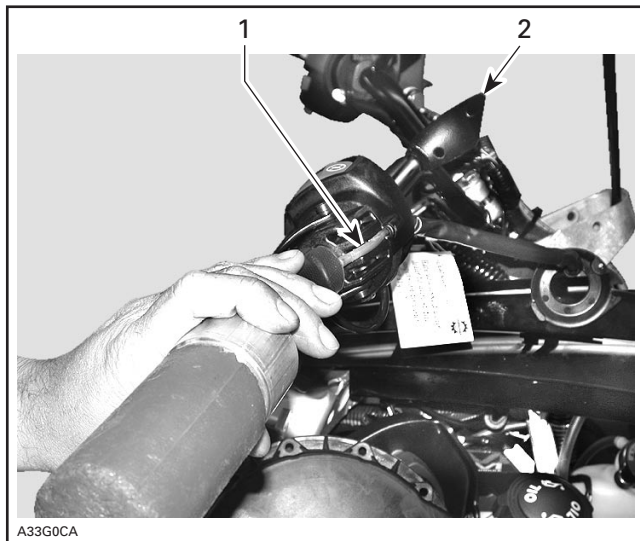

1. Harness
2. Windshield bracket

Properly route harness then reinstall removed parts.

Section 10 STEERING/FRONT SUSPENSION

Subsection 01 (STEERING SYSTEM)

Reinstall terminals and replugin connectors. Test grips to ensure they heat properly.

Steering Column

Unfasten windshield. Remove cap **no. 3** or steering padding **no. 23** according to model.

Remove console. Refer to STEERING COLUMN POSITION ADJUSTMENT below.

Cut locking ties retaining harnesses to steering column **no. 1**.

Unbolt handlebar ass'y and move it aside.

Remove tuned pipe.

Detach the short tie rod **no. 8** from the steering column. Note that a hardened flat washer **no. 7** goes on each side of steering column lever.

Disengage carriage bolts **no. 6** from steering column support **no. 15**. Remove lower plastic U-clamps from steering column.

Disengage carriage bolts **no. 5** from steering support. Remove upper plastic U-clamps from steering column.

Pull steering column from top.

If, for any reason, the master cylinder has been removed from handlebar note that its clamp **no. 27** must be installed with the embossed arrow pointing downward. Torque screws to $8 \text{ N}\cdot\text{m}$ ($71 \text{ lbf}\cdot\text{in}$) beginning with the bottom screw.

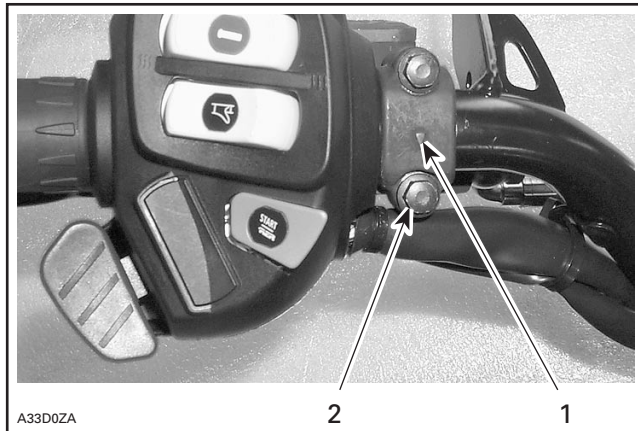

1. Arrow on clamp pointing downward
2. Tighten bottom screw first

Refer to HANDLEBAR POSITION ADJUSTMENT for handlebar reinstallation.

RH and LH Swivel Arm

At assembly respect UP mention.

Grease fitting **no. 16** of swivel arms **no. 14** must face toward center of vehicle.

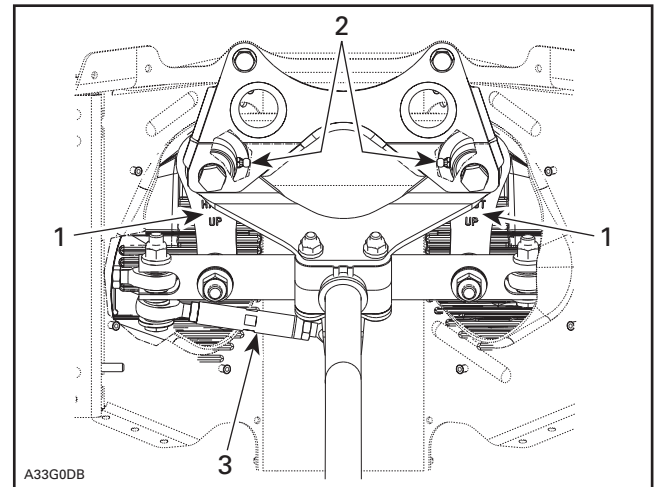

1. UP mention
2. Grease fittings
3. Small tie rod

Ball Joint (left hand and right hand threads)

The maximum external threaded length not engaged in the tie rod must not exceed 20 mm ($25/32 \text{ in}$).

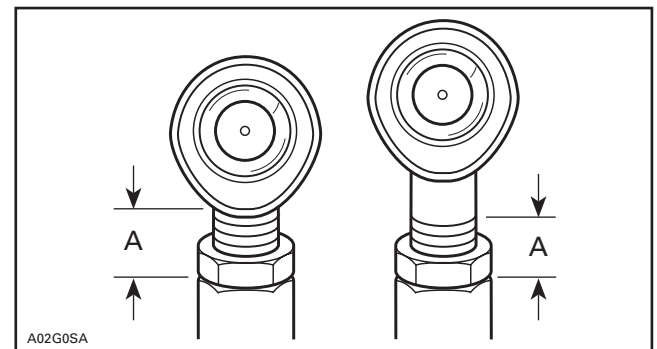

- TYPICAL
A. 20 mm ($25/32 \text{ in}$) max.

The ball joint **no. 17** and **no. 18** should be restrained when tightening the tie rod end lock nut. Align it so the tie rod end is parallel to the steering arm when assembled on the vehicle, refer to the following illustration.

For proper torque specifications refer to the specific exploded view for the vehicle being serviced.

Section 10 STEERING/FRONT SUSPENSION

Subsection 01 (STEERING SYSTEM)

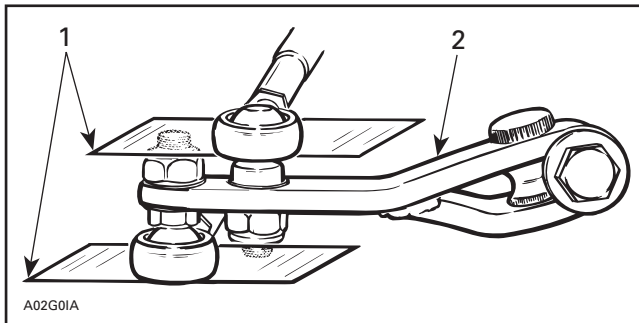

TYPICAL
1. Parallel with steering arm
2. Steering arm

⚠ WARNING

The cut off section of the ball joint must run parallel with the swivel bar no. 9. When tightening lock nuts, restrain ball joint with appropriate size wrench. The maximum external threaded length not engaged in the tie rod must not exceed 20 mm (25/32 in).

Hardened Washer

Install a hardened washer no. 7 on each side of the ski leg and each side of the steering column lever.

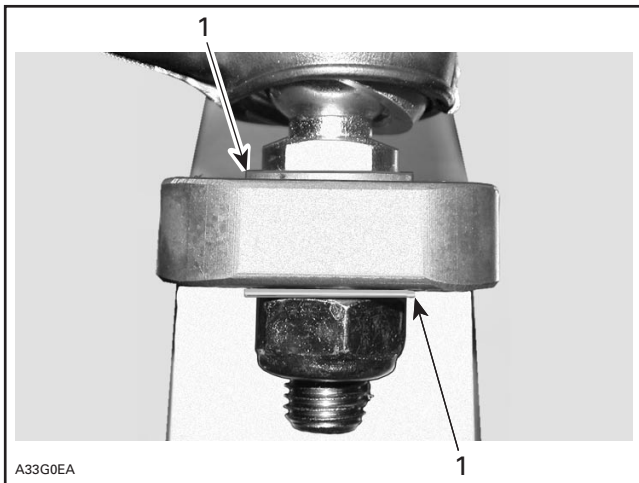

TYPICAL
1. Hardened washers

INSPECTION

Check skis and runners for wear. Replace as necessary. Refer to FRONT SUSPENSION.

Check the general condition of the steering system components for wear. Replace if necessary.

Heating Grip Element

Refer to TESTING PROCEDURE for checking heating element no. 13 of grip.

Ball Joint (left hand and right hand threads)

Inspect ball joint ends no. 17 and no. 18 and small tie rod ends for wear or looseness, if excessive, replace them.

ADJUSTMENT

Steering Column Position Adjustment *Some Models*

⚠ WARNING

Do not drill additional holes to customize steering column position.

Steering column position is adjustable. Proceed as follows.

There are 2 positions.

NOTE: Following procedure describes how to change steering column position from rearward to forward position.

Unscrew 4 bolts retaining windshield assembly to handlebar. Remove windshield assembly.

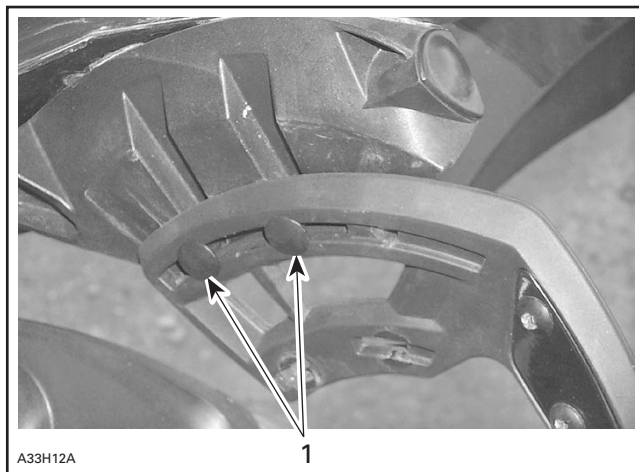

ONE SIDE SHOWN — REARWARD POSITION
1. Bolts retaining windshield assembly

Remove cap no. 3 or steering padding no. 23 according to model and remove console cap.

Section 10 STEERING/FRONT SUSPENSION

Subsection 01 (STEERING SYSTEM)

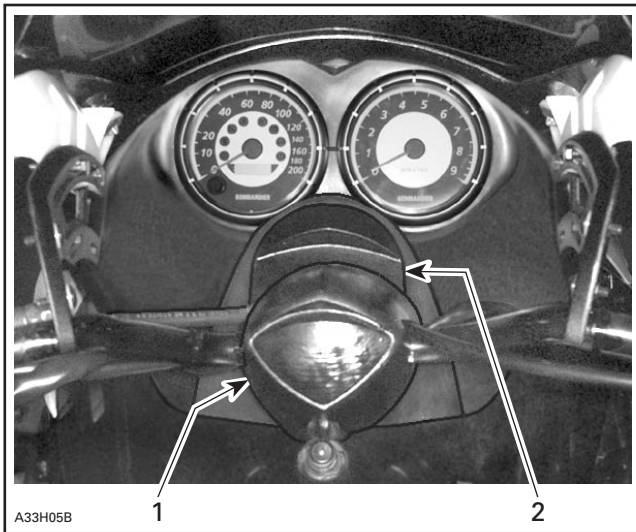

1. Cap
2. Console cap

Unscrew 4 bolts retaining console.

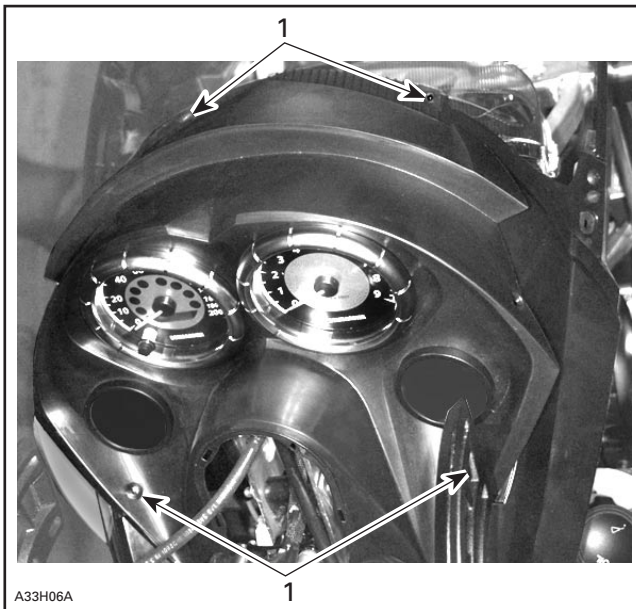

1. Bolts retaining console

Slightly lift console to gain access to electrical connector housings. Unplug the 2 large connector housings and then separate 3-wire connector.

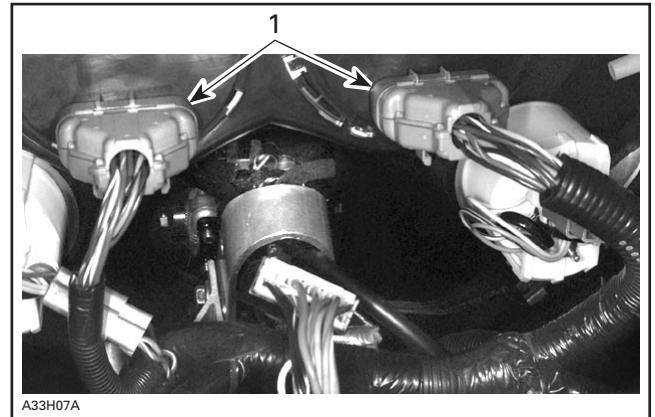

- TYPICAL*
1. Large connector housings

Remove console.

Remove 2 bolts no. 5 retaining top of steering column.

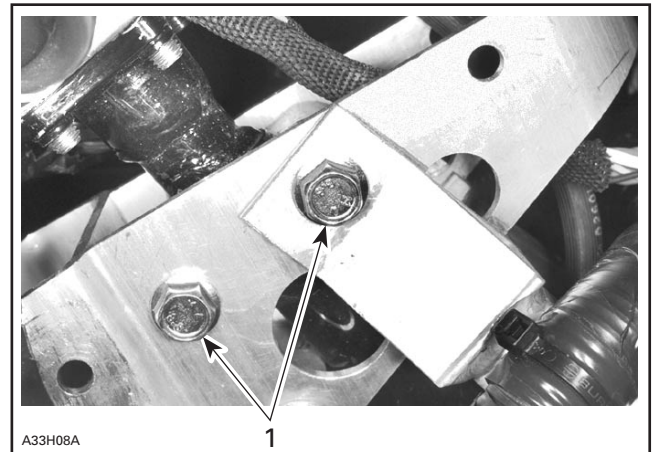

- STEERING COLUMN IN REARWARD POSITION*
1. Two bolts retaining top of steering column

Move steering column to forward position.

Section 10 STEERING/FRONT SUSPENSION

Subsection 01 (STEERING SYSTEM)

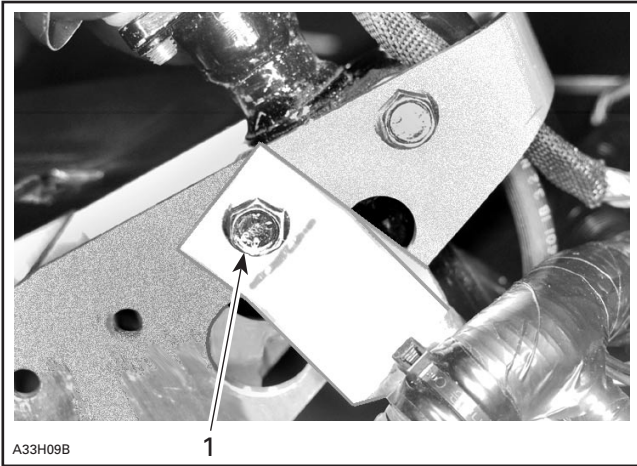

STEERING COLUMN IN FORWARD POSITION
1. Longer bolt

Reinstall the 2 bolts **no. 5**. Always install the longer bolt on thicker portion to be bolted. Use new lock nuts. Torque nuts to 25 N•m (18 lbf•ft).

Reconnect the electrical connectors and reinstall all removed parts.

Position of console cap will be inverted. Instead of being above it will be beneath steering column.

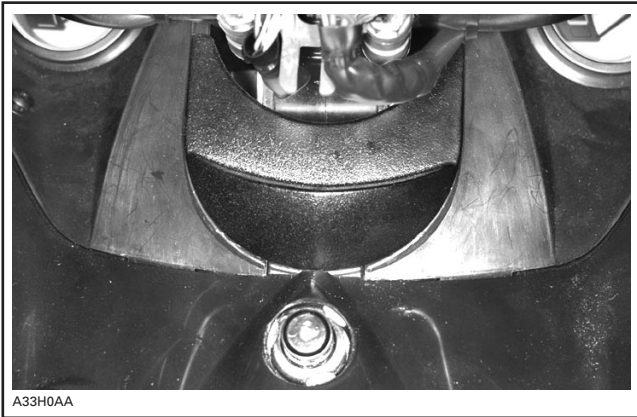

CONSOLE CAP INSTALLED BENEATH STEERING COLUMN

Reinstall windshield assembly to handlebar. Refer to WINDSHIELD ADJUSTMENT below.

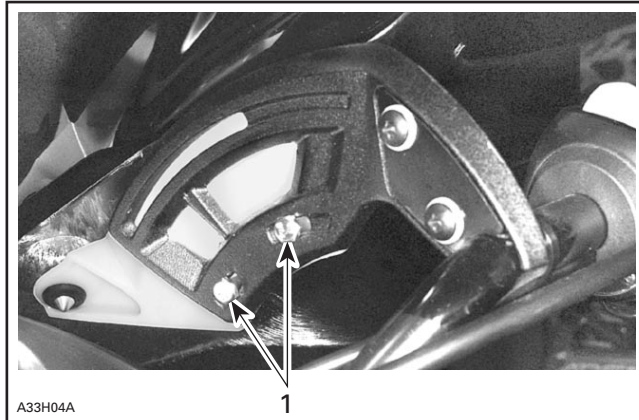

ONE SIDE SHOWN — FORWARD POSITION
1. Bolts retaining windshield assembly

Readjust throttle lever housing **no. 21** and switch housing accordingly to optimal angle so that you will not need to release your grip to operate levers.

WARNING

Adjust with vehicle at rest in a safe place. Securely retighten all fasteners. Never rotate throttle lever to operate with fingers instead of thumb.

Handlebar Extension

Some Models

When installing handlebar extension **no. 29**, ensure to position the rounded opening at the bottom and to tilt the extension so that it rests against steering support stopper.

Section 10 STEERING/FRONT SUSPENSION

Subsection 01 (STEERING SYSTEM)

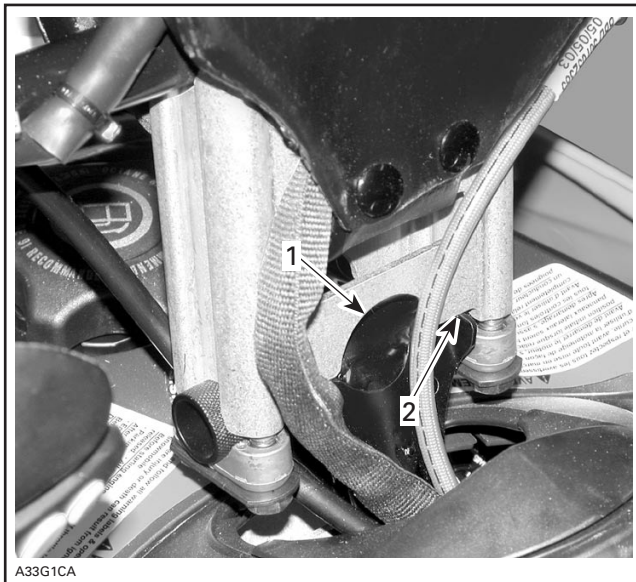

1. Opening here
2. Extension against stopper

Handlebar Position Adjustment

The handlebar position can be adjusted to suit driver's preferences.

Loosen all 4 bolts no. 4 retaining handlebar to steering column.

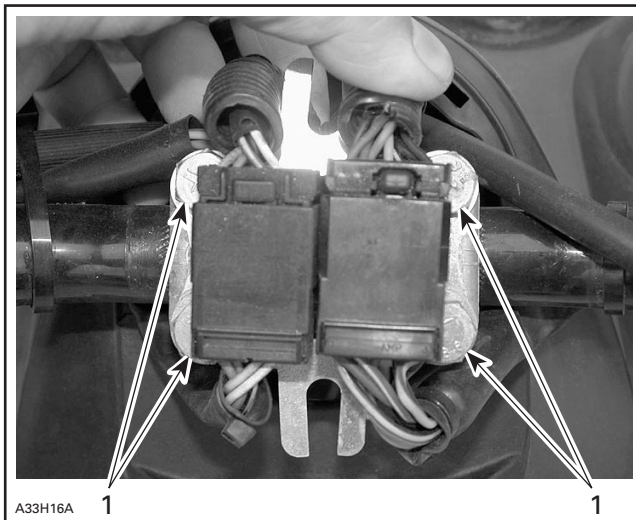

1. Four bolts

Move handlebar to the desired position. Torque all 4 bolts no. 4 to 25 N•m (18 lbf•ft).

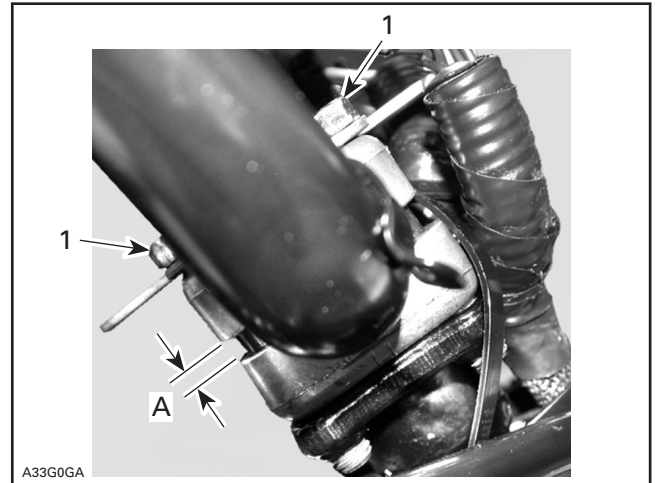

1. Torque to 25 N•m (18 lbf•ft)
- A. Equal gap all around

CAUTION: Tighten the bolts equally in a criss-cross sequence and ensure there is an equal gap on each side of the clamps no. 2.

WARNING

Avoid contact between the brake handle and the windshield by NOT adjusting the handlebar too high.

Readjust throttle lever housing no. 21 and switch housing accordingly to optimal angle so that you will not need to release your grip to operate levers.

WARNING

Adjust with vehicle at rest in a safe place. Securely retighten all fasteners. Never rotate throttle lever to operate with fingers instead of thumb.

Readjust windshield for proper fit with console. Refer to WINDSHIELD ADJUSTMENT below.

Windshield Adjustment

The windshield can be adjusted to properly fit with console.

Before adjusting windshield, make sure it is installed on the proper bracket slots according to steering column position. See photos below.

Slots in brackets allow different windshield positions. Move windshield to fit with console. Retighten 4 nuts to 5 N•m (44 lbf•in).

Check that windshield does not touch console after adjustment.

Section 10 STEERING/FRONT SUSPENSION

Subsection 01 (STEERING SYSTEM)

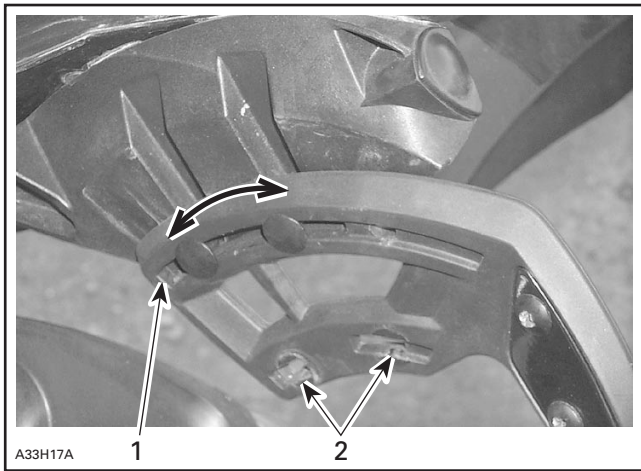

1. Slot when windshield is installed in rearward steering column position
2. Slots when windshield is installed in forward steering column position

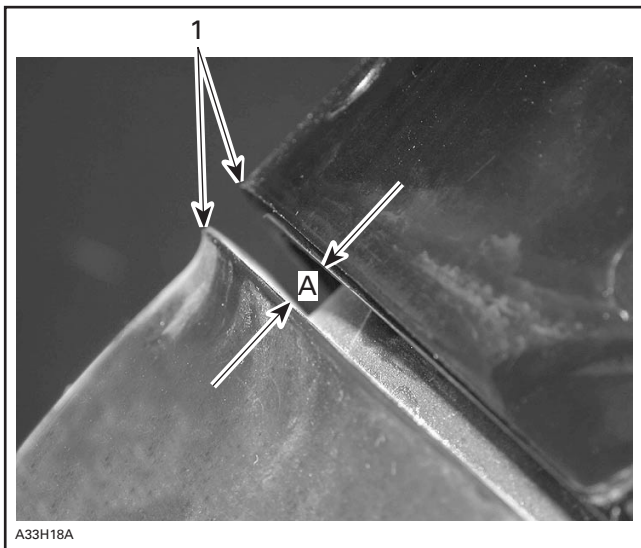

PROPER FIT OF WINDSHIELD VERSUS CONSOLE

1. In line
- A. 8 to 12 mm (3/8 to 1/2 in)

Handlebar Strap

Some Models

Ensure to position strap no. 28 symmetrically each side of steering support and so that its rubber band is on the inner side. Tilt strap 5° towards driver relative to steering column axis or relative to handlebar extension on so equipped models.

On Renegade X and Summit Series, position strap between rubber band and screw end to protect the rubber band.

Retaining clip and hardware must be installed in the same position on both strap ends.

J-Hook Adjustment

Some Models

Position J-hook so that its curved end is pointing downward and is roughly vertical. Ensure to adjust J-hooks at the same position each side.

Hand Guard Adjustment

Some Models

Position RH guard 8 mm (5/16 in) from throttle housing and LH guard 4 mm (5/32 in) from brake retaining clamp. Position hand guards so that their inner face is roughly vertical. Torque top screw first to 3.5 N•m (31 lbf•in) then torque bottom screw.

STEERING ADJUSTMENT (SKIS)

Definitions

TOE-OUT:

A difference measured between the front edge of the ski bridge «A» and rear edge of ski bridge «B» as viewed from the top.

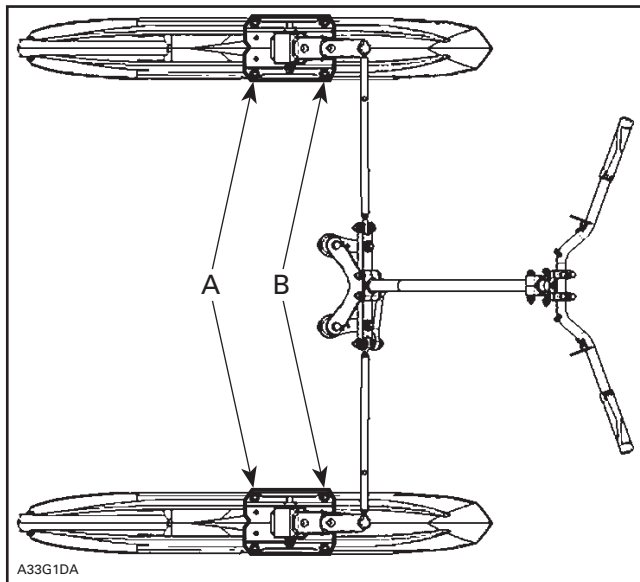

Adjustments

SKI ALIGNMENT AND TOE-OUT

Ski alignment and toe-out are performed by adjusting length of left and right tie rods no. 11.

Section 10 STEERING/FRONT SUSPENSION

Subsection 01 (STEERING SYSTEM)

Procedure:

- Position handlebar so that it is in straight ahead position by measuring from the extremities of the grips to the rear most edge of the tunnel, as shown.

NOTE: The reference point must be the same relative to each side.

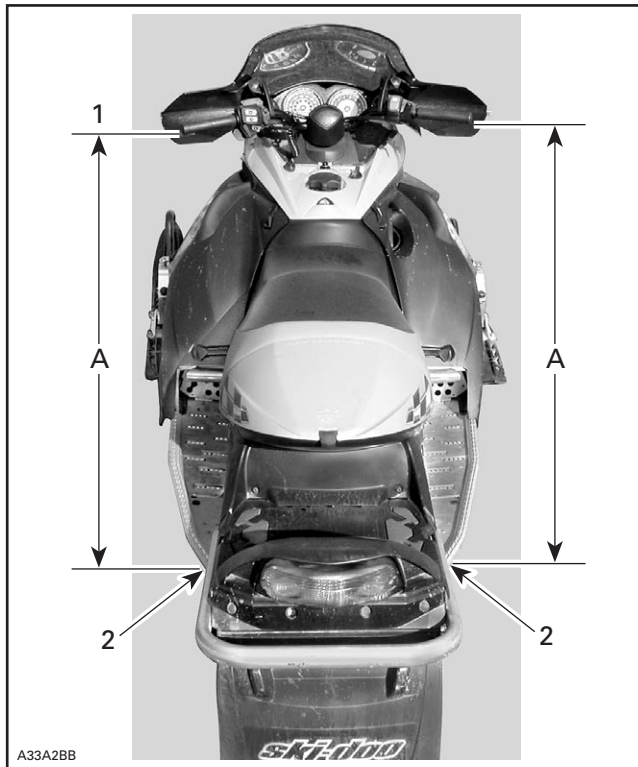

1. Equal distance «A» on each side
2. Same reference point

- Hook a rubber cord in front of skis to keep them closed and to take all slack from steering mechanism.
- Leave the vehicle on the ground on its own weight.
- Place a straight edge against pre-adjusted track and measure the distance between front and rear of ski bridge.

MODEL	TOTAL TOE-OUT ± 1 mm (± 3/64 in)
All REV Series	2 (5/64)

NOTE: To reduce tolerance when measuring, set one ski to proper toe-out (half the total toe-out) then measure from that ski to the opposite ski.

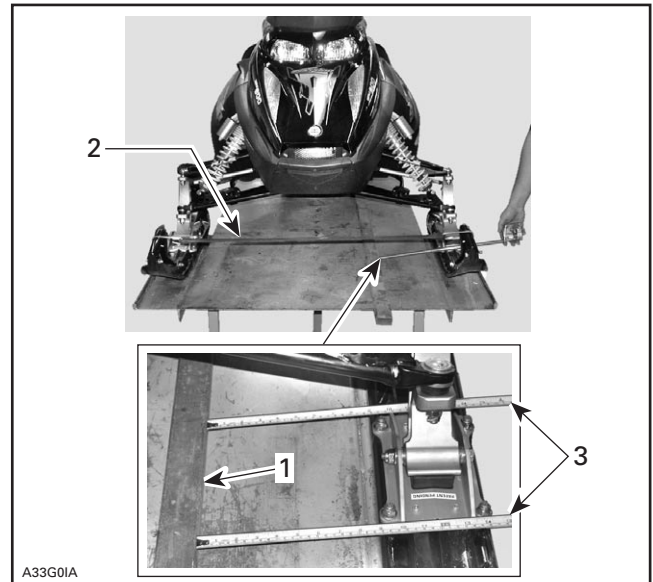

TYPICAL

1. Straight edge
2. Rubber cord
3. Measure at rear and front of ski bridge

If adjustment is needed:

- Loosen jam nuts of both tie rods no. 11.
- Turn the tie rod to change its length.
- Retighten jam nuts.

WARNING

Never lengthen tie rod so that the external unengaged threaded portion of ball joint exceeds 20 mm (25/32 in).

Once ski alignment is done check that ski leg rests against lower arm or is not more than 2 mm (5/64 in) from lower arm when the handlebar is fully turned.

Section 10 STEERING/FRONT SUSPENSION

Subsection 01 (STEERING SYSTEM)

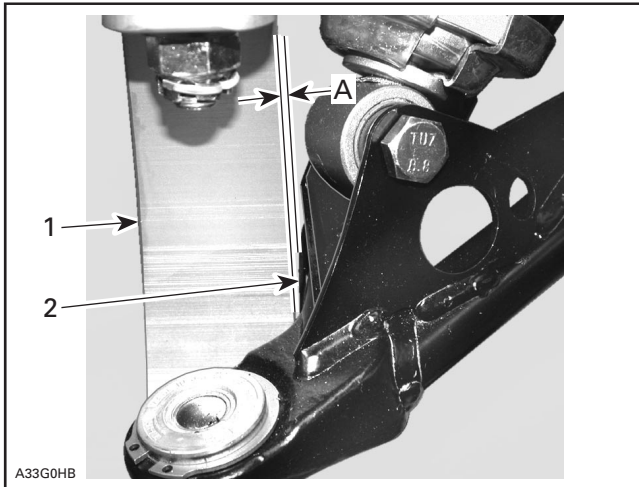

RIGHT HAND SIDE SHOWN

- 1. Ski leg
- 2. Lower arm
- A. 2 mm (5/64 in)

If the distance is more than the specified distance on one side then check for bent parts.

LUBRICATION

WARNING

Do not lubricate throttle cable or housing.

Use suspension synthetic grease (P/N 293 550 033) on:

- Grease fitting **no. 16** of LH and RH swivel arms.
- Lower steering column bushing.

Use BOMBARDIER LUBE (P/N 293 600 016) on:

- Tie rod ball joints.

FRONT SUSPENSION

SERVICE TOOLS

Description	Part Number	Page
A-arm nut wrench.....	529 035 876	456
ball joint installer.....	529 035 975	456
ball joint lock tool.....	529 035 945	456
ball joint remover.....	529 035 827	452-453
ball joint remover support.....	529 035 873	452
ball joint support.....	529 035 875	456
shock absorber spring remover.....	529 035 504	451

SERVICE PRODUCTS

Description	Part Number	Page
pulley flange cleaner.....	413 711 809	456
suspension synthetic grease.....	293 550 033	459

Section 10 STEERING/FRONT SUSPENSION

Subsection 02 (FRONT SUSPENSION)

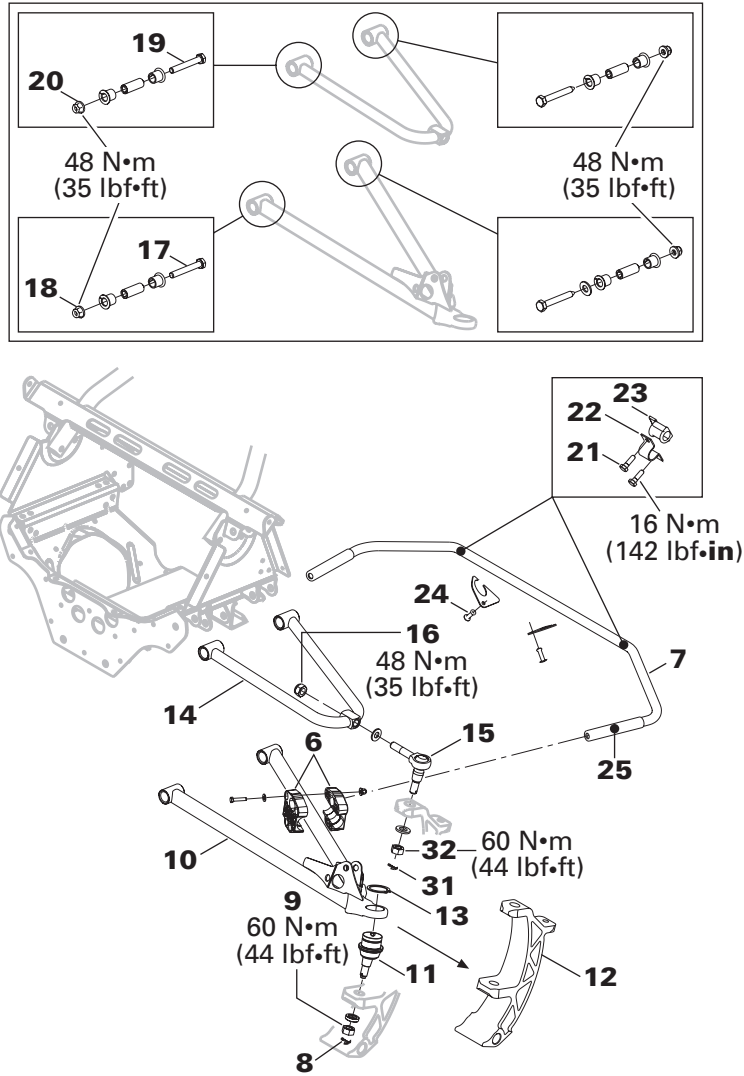

A33F53S

Section 10 STEERING/FRONT SUSPENSION

Subsection 02 (FRONT SUSPENSION)

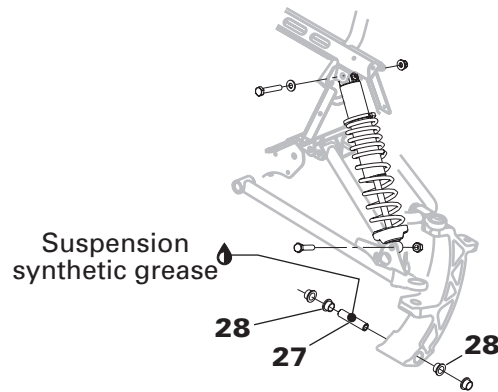
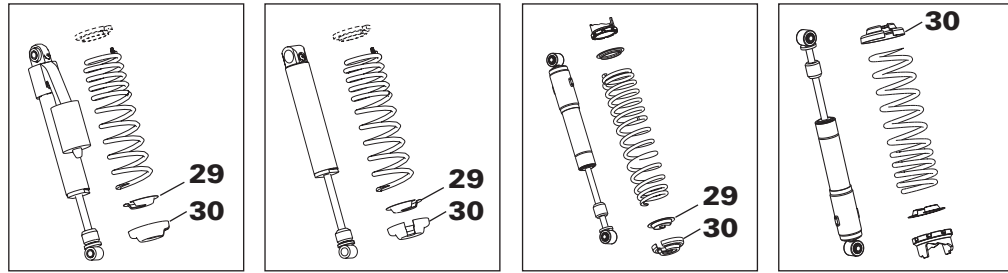

Precision Ski

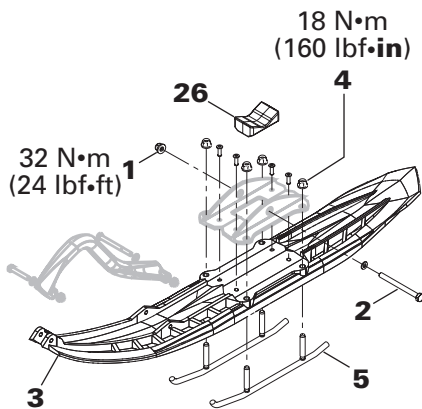

Mountain Ski

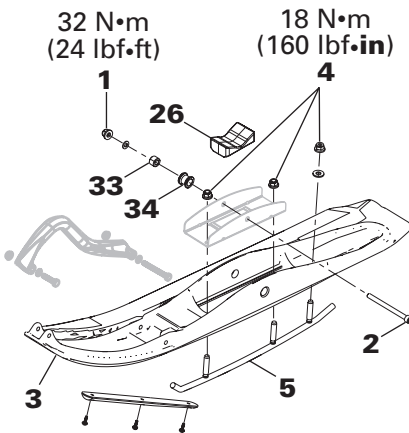

Plastic Ski

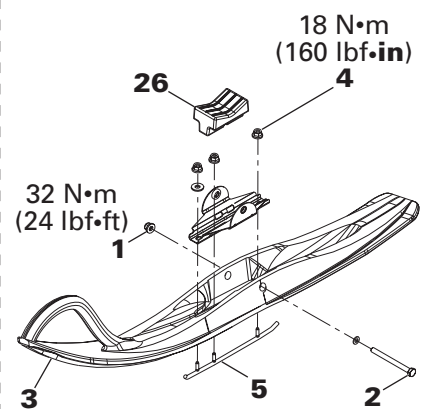

A33F54S

NOTE: The same procedure applies on both sides.

Section 10 STEERING/FRONT SUSPENSION

Subsection 02 (FRONT SUSPENSION)

GENERAL INSPECTION

Check for looseness, bent, worn out, rusted or other damage on components. Ensure cotter pins are in good condition and properly secured. Replace the faulty component.

To check upper arm bushings and ball joint:

- Let vehicle weight compress the suspension.
- Firmly grab upper part of ski leg and try to move sideways to feel the free-play.
- If excessive play is felt, replace the faulty component.

To check lower arm bushings and ball joint:

- Raise front of vehicle off the ground from the frame to release the suspension.
- Firmly grab lower part of ski leg and try to move sideways to feel the free-play.
- If excessive play is felt, replace the faulty component.

DISASSEMBLY

Ski

Lift front of vehicle and support it off the ground. Unscrew nut **no. 1** then pull screw **no. 2** out. Remove ski **no. 3**.

Unscrew nuts **no. 4** and remove ski runners **no. 5**.

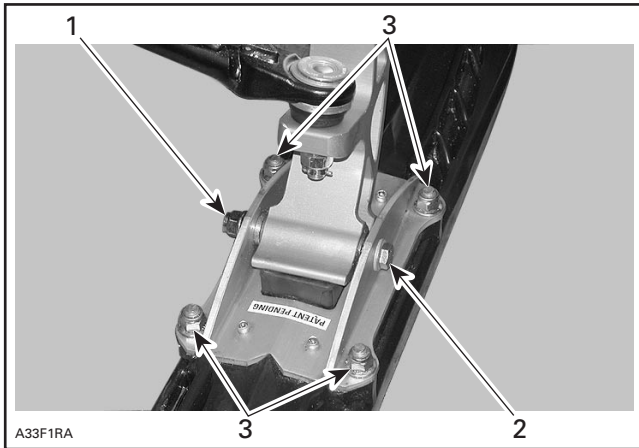

PRECISION SKI
1. Unscrew nut
2. Remove screw
3. Ski runner nuts

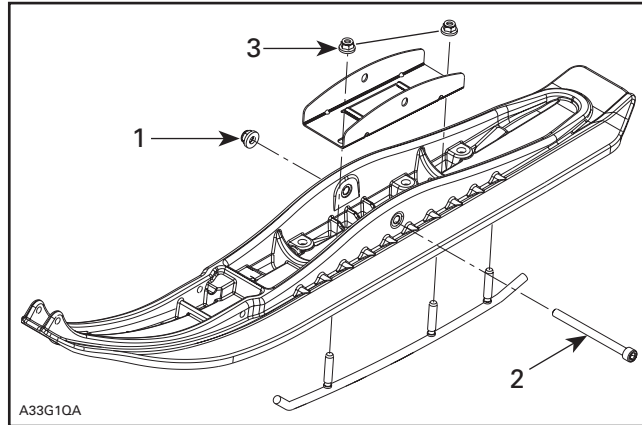

MOUNTAIN SKI
1. Unscrew nut
2. Remove screw
3. Ski runner nuts

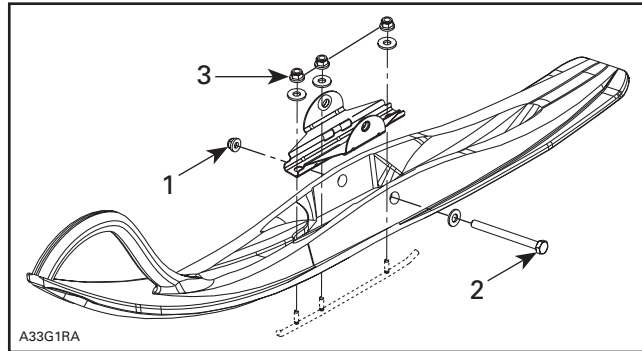

PLASTIC SKI
1. Unscrew nut
2. Remove screw
3. Ski runner nuts

Shock Absorber

Open hood and remove side panels.

Reduce spring preload by turning adjusting ring towards position 1 and continue until it stops.



Section 10 STEERING/FRONT SUSPENSION

Subsection 02 (FRONT SUSPENSION)



A33F1TA

Remove lower screw then upper screw of shock absorber.

NOTE: To retain upper screw while unscrewing nut, remove access plug in engine compartment.

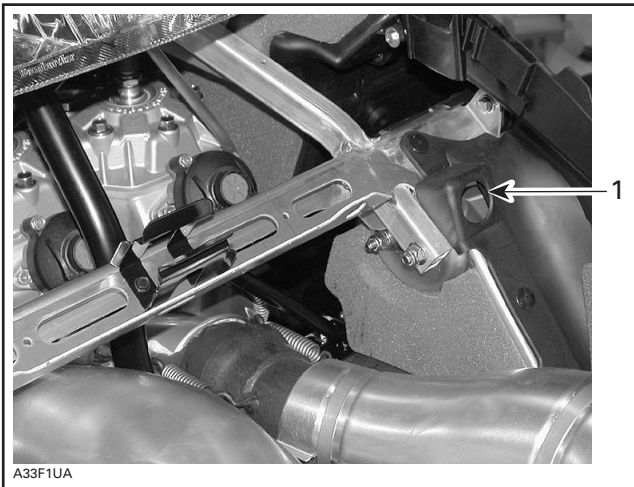

A33F1UA

1. Access hole to reach upper screw

For shock absorber spring disassembly use shock absorber spring remover (P/N 529 035 504) in a vise. Mount shock absorber in it and turn shock absorber so that spring coils match spring compressor.

Close and lock the bar. Adjust the handle at horizontal position by changing the position of the clevis pin.

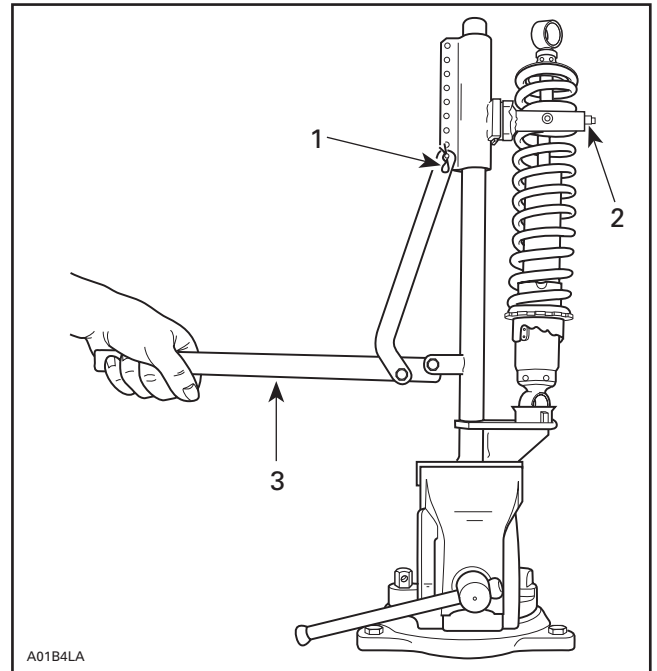

A01B4LA

TYPICAL

1. Clevis pin
2. Bar
3. Handle horizontal

Push down on the handle until it locks. Remove spring stopper then release handle.

Some Models

At installation, cap opening **no. 30** must be 180° from spring stopper **no. 29** opening.

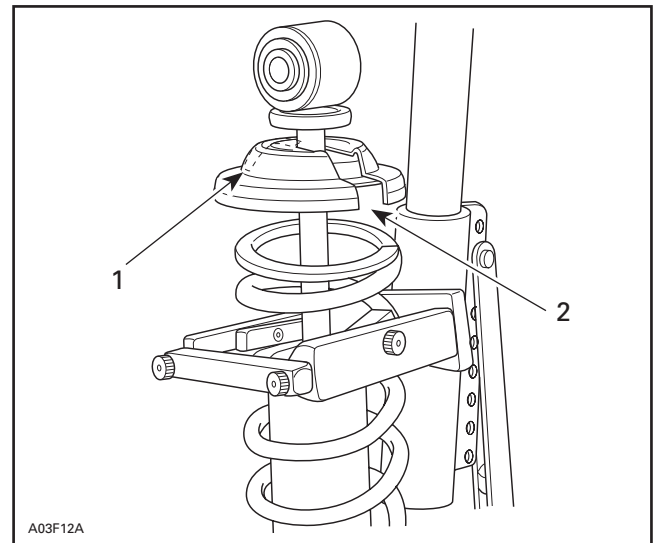

A03F12A

1. Cap opening
2. Spring stopper opening

Section 10 STEERING/FRONT SUSPENSION

Subsection 02 (FRONT SUSPENSION)

Lower Arm

Remove shock absorber.

Remove sliding blocks no. 6 of stabilizer bar no. 7.

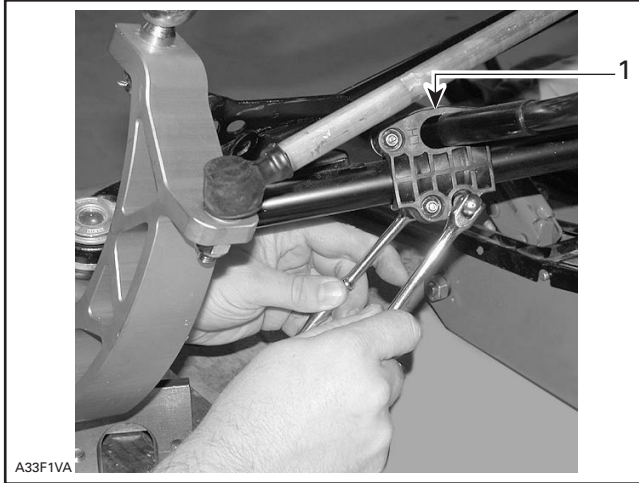

1. Sliding blocks

Remove cotter pin no. 8 and unscrew ball joint nut no. 9.

Raise lower arm no. 10 so that ball joint no. 11 becomes parallel with ski leg no. 12.

Install ball joint remover (P/N 529 035 827) and detach ball joint from ski leg.

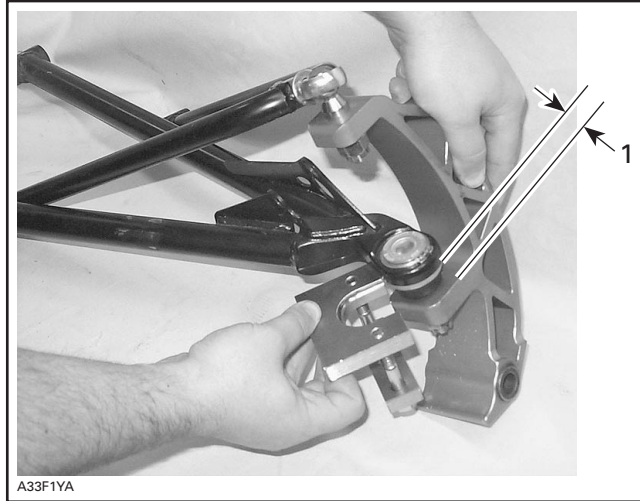
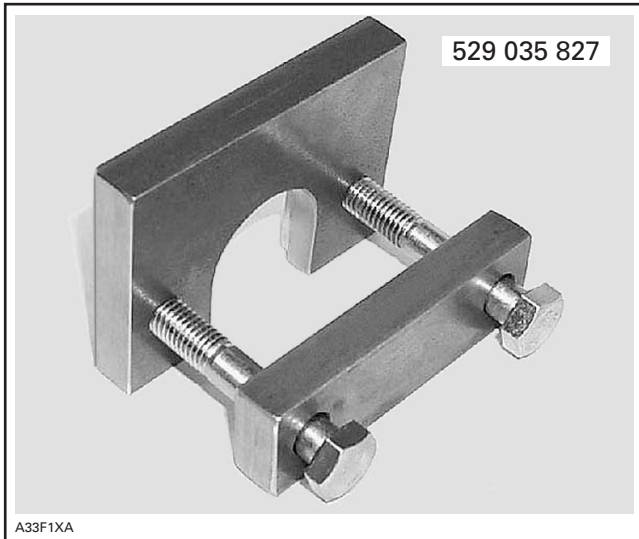

TYPICAL

1. Ball joint parallel with ski leg

Remove lower arm no. 10 from frame. For front screw no. 17 removal, hold nut no. 18 from engine compartment.

To remove ball joint, proceed as follows:

- Remove snap ring no. 13.
- Install ball joint remover support (P/N 529 035 873) under joint.
- Press joint out.



TYPICAL

Section 10 STEERING/FRONT SUSPENSION

Subsection 02 (FRONT SUSPENSION)

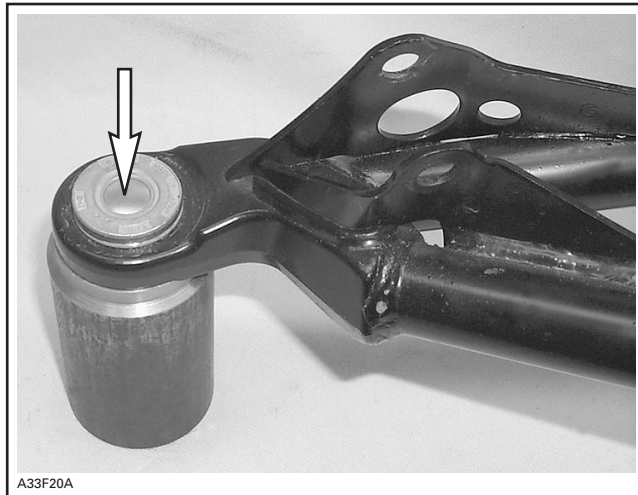

TYPICAL

Tie Rod

Refer to STEERING SYSTEM section and remove tie rod from ski leg.

Upper Arm

Remove cotter pin **no. 31** and unscrew ball joint nut **no. 32**.

Install ball joint remover (P/N 529 035 827) and detach ball joint **no. 15** from ski leg.



Use a 11 mm (7/16 in) open wrench to hold ball joint housing and unscrew nut **no. 16**, then remove ball joint from upper arm.

Remove upper arm **no. 14** from frame. For screws **no. 19** removal, hold nuts **no. 20** from engine compartment.

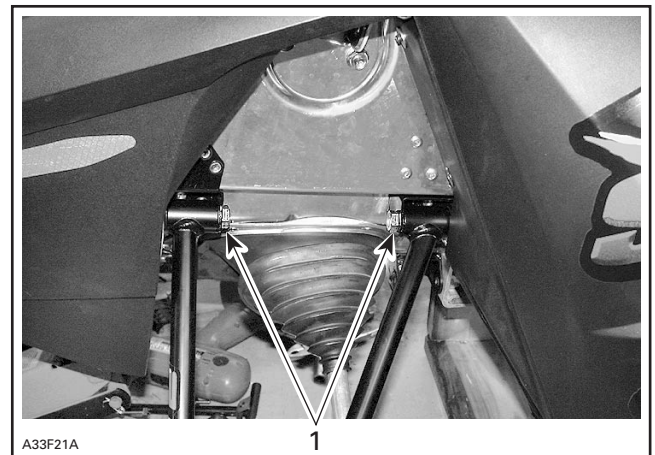

1. Remove screws while holding nuts from engine compartment

Stabilizer Bar

Remove shock absorbers, stabilizer bar slider blocks and unfasten lower ball joints from ski legs.

Remove screws **no. 21** from clamps **no. 22**.

Section 10 STEERING/FRONT SUSPENSION

Subsection 02 (FRONT SUSPENSION)

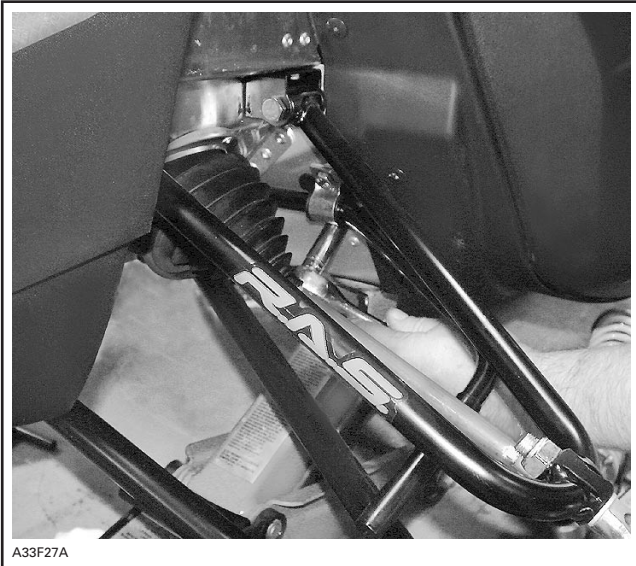

Using a 4.8 mm (3/16 in) drill bit, drill rivet **no. 24** out. Remove cap.

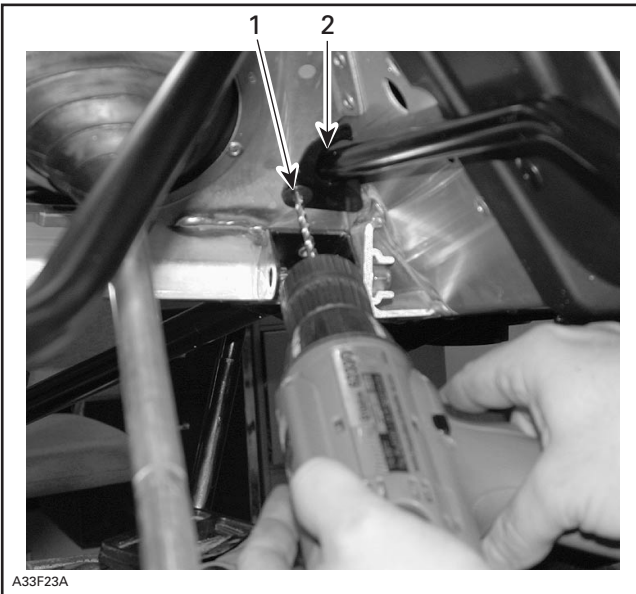

1. Drill rivet out with a 4.8 mm (3/16 in) drill bit
2. Cap

Lift front of vehicle enough so that stabilizer bar **no. 7** can be rotated downward to allow to slide it out.

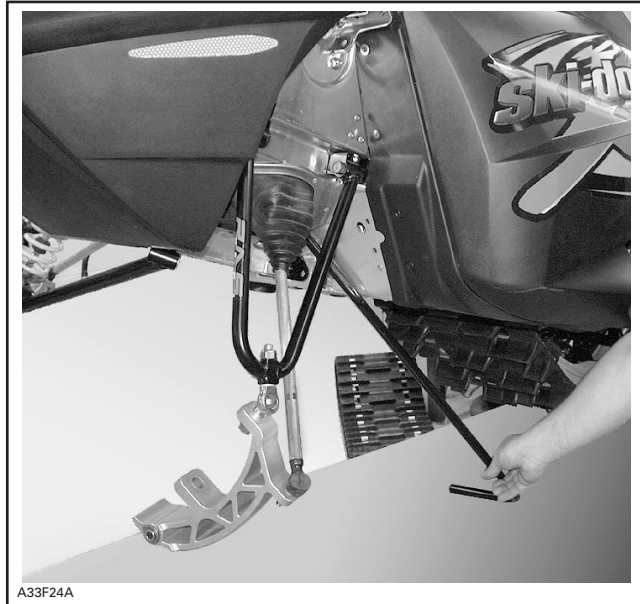

To remove bushing **no. 25**, use a 13 mm (1/2 in) open wrench and tap bushing out as shown.

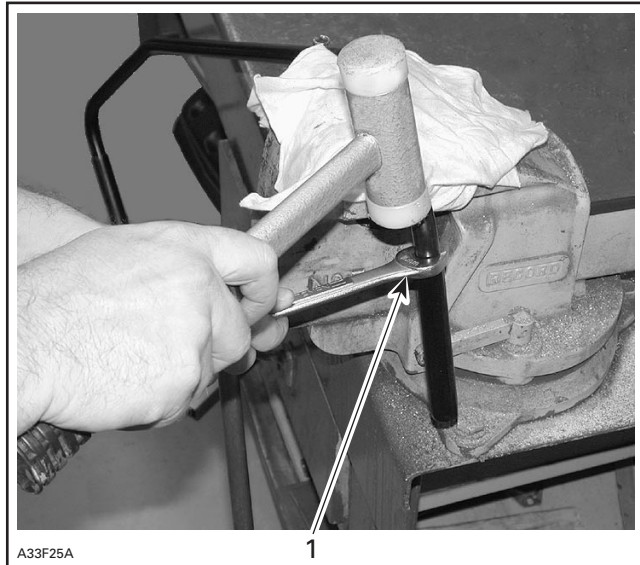

1. Use a 13 mm (1/2 in) open wrench to push bushing out

INSPECTION

Check all plastic bushings for wear. Replace as required.

Check condition of ski leg **no. 12**. Replace as required.

Check for straightness of lower and upper arms. Replace as required.

Section 10 STEERING/FRONT SUSPENSION

Subsection 02 (FRONT SUSPENSION)

Check condition of ball joints. Replace as required.

Check skis and runners **no. 5** for wear, replace as necessary.

Check condition of ski stopper **no. 26**. Replace it when deteriorated.

To check condition of shock absorber, refer to sub-section SHOCK ABSORBER INSPECTION AND SERVICING in section REAR SUSPENSION.

INSTALLATION

For assembly, reverse the disassembly procedure. However, pay attention to the following.

Tighten nuts and screws to proper torque as mentioned in exploded view.

Nuts with a cotter pin: After applying the proper torque, continue tightening as necessary to allow cotter pin insertion. Ensure to properly secure cotter pin.

WARNING

Always install new cotter pins at assembly and properly bend their ends.

Stabilizer Bar

Ensure to properly position stabilizer bar before insertion in frame.



Install the stabilizer bar bushing **no. 23** making sure to place its tab over the access hole located on the LH side.

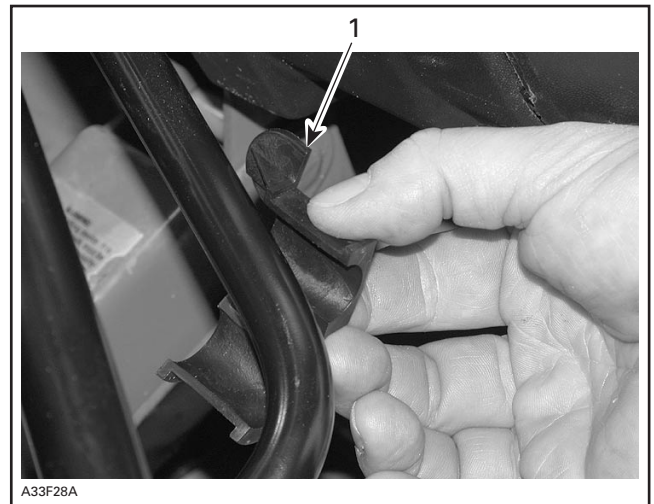

1. Install bushing as shown

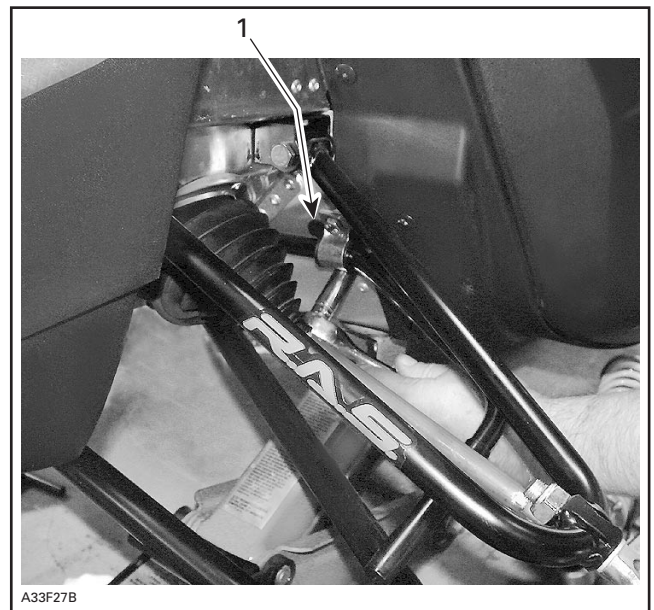

1. Tab here to obstruct access hole

Upper Arm

When installing ball joint **no. 15** to upper arm, ensure to tilt it with the proper angle as shown. The ball joint housing must be parallel to ski leg tab. This mounting position corresponds to $10^{\circ} \pm 3^{\circ}$ angle from upper arm.

Section 10 STEERING/FRONT SUSPENSION

Subsection 02 (FRONT SUSPENSION)

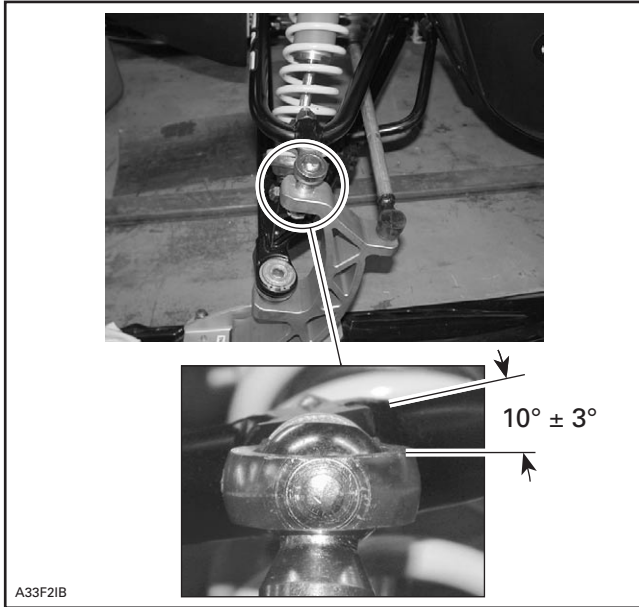

Lower Arm

Position lower arm below stabilizer bar.

Prior to installing ball joint in lower arm, ensure to clean the tapered surfaces with the pulley flange cleaner (P/N 413 711 809). Surface contacts must be clean and free of dirt, oil and grease. Apply the cleaner on a rag then use the rag to clean the surfaces of ball joint and ski leg.

To install ball joint, proceed as follows:

- Install ball joint support (P/N 529 035 875) on top side of lower arm (operating position).
- Position ball joint installer (P/N 529 035 975) on bottom side of lower arm (operating position).
- Press joint in.
- Install snap ring **no. 13** with its opening toward front of vehicle.

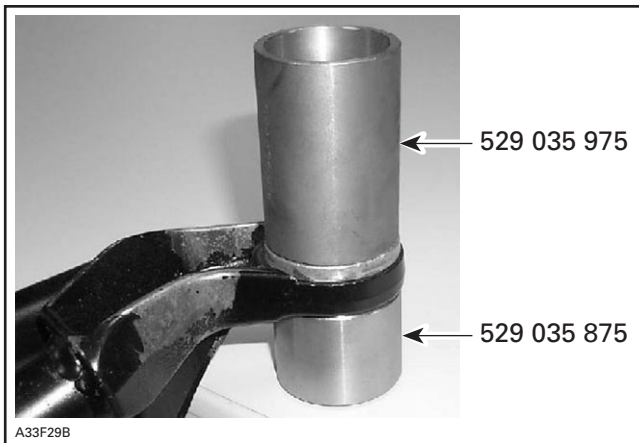

To properly torque ball joint nut, use the A-arm nut wrench (P/N 529 035 876).



Ensure to install the tool perpendicularly (90°) to torque wrench.

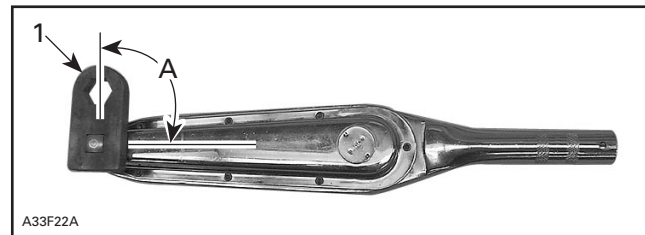

1. Tool perpendicular (90°) to torque wrench
A. 90°

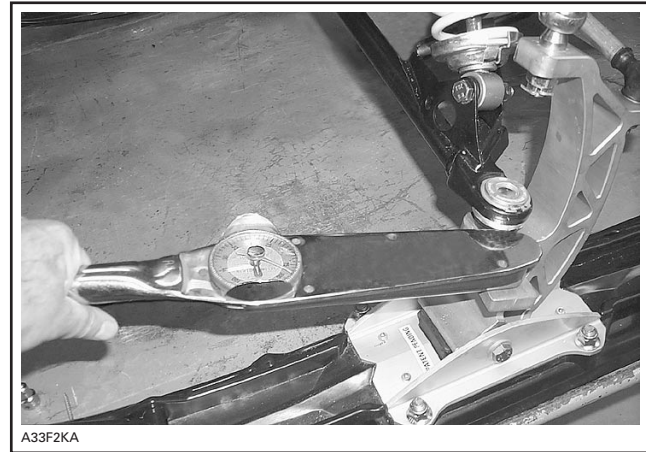

Use ball joint lock tool (P/N 529 035 945) to restrain ball joint during nut tightening.

NOTE: The upper arm ball joint has to be removed in order to use this tool. Also remove the small screw from top of ball joint to allow proper seating of tool.

Section 10 STEERING/FRONT SUSPENSION

Subsection 02 (FRONT SUSPENSION)

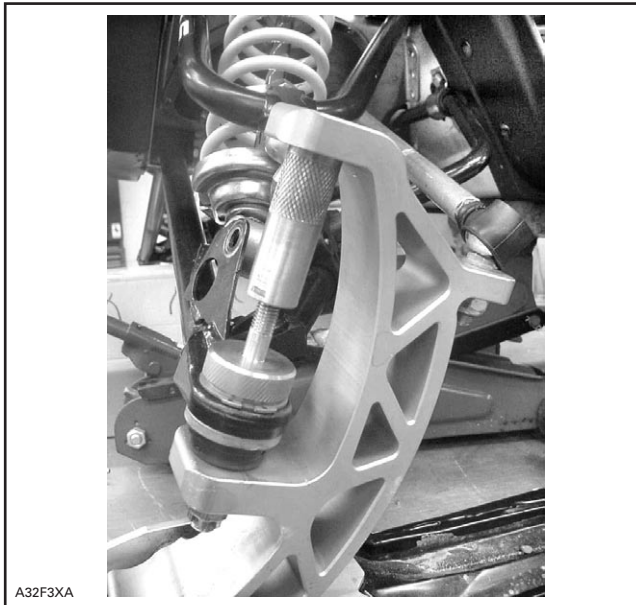

TYPICAL

Stabilizer Bar

Notice that LH and RH sliding blocks are different. Look for their molded identification with LH or RH letters.

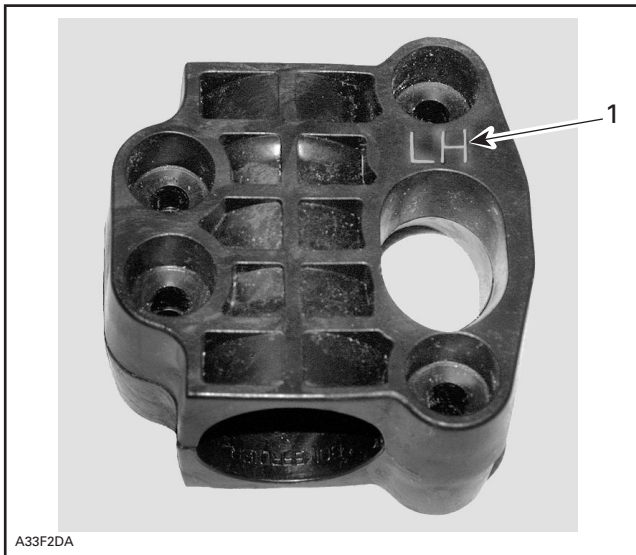

1. Molded identification for proper side installation

To install sliding blocks:

- Temporarily rotate the rear block by 180°.
- Insert on stabilizer bar end and push beyond the lower arm.
- Rotate block back by 180° to its normal position.
- Install the other block half.

- Install screws and nuts.
- Ensure blocks slide easily when compressing and releasing suspension.



1. Temporarily rotate block by 180° for its insertion

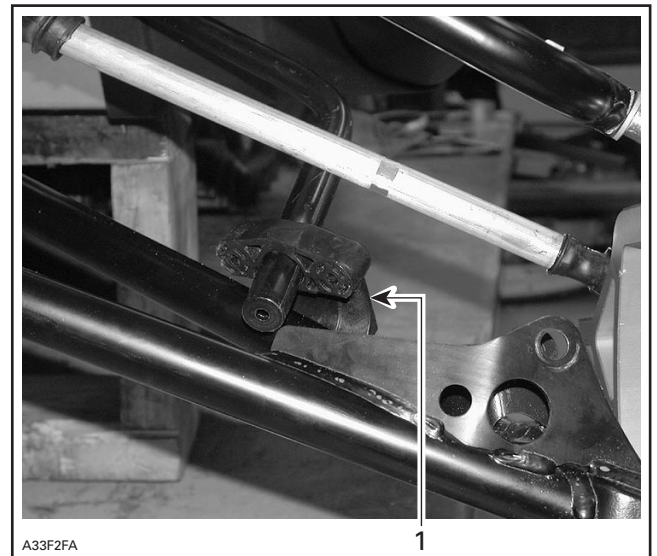

1. Push block on bar end beyond lower arm then rotate back to its normal position

Shock Absorber

Ensure to reinstall shock absorber in the proper position according to model.

Section 10 STEERING/FRONT SUSPENSION

Subsection 02 (FRONT SUSPENSION)

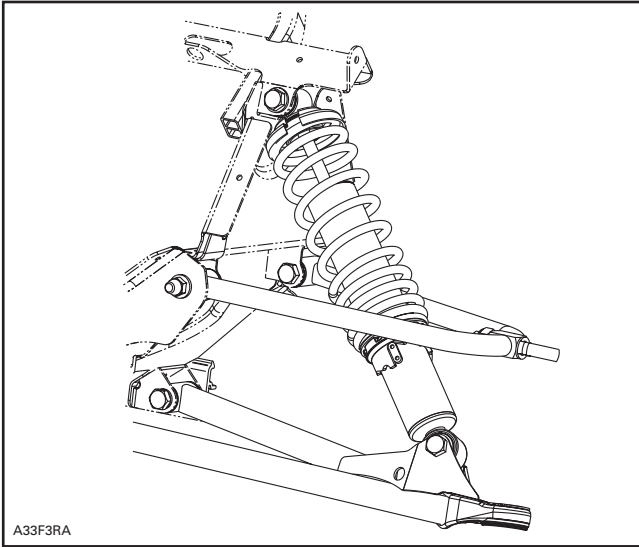

A33F3RA
GSX Sport
GTX Sport
MX Z Trail
Summit Adrenaline

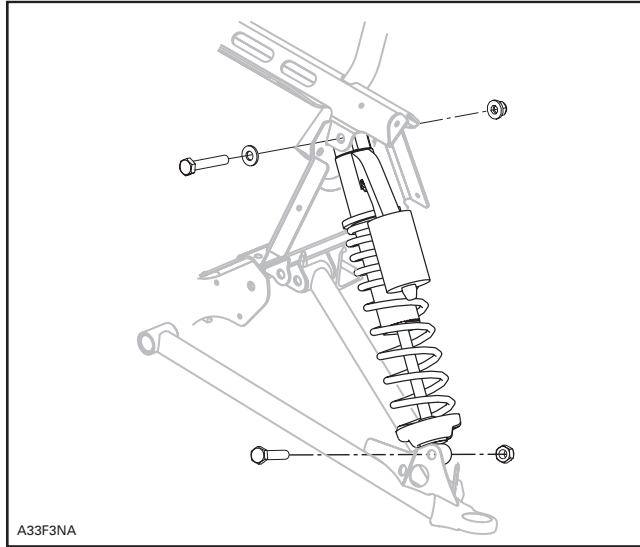

A33F3NA
MX Z
All X package
Adrenaline (Europe)
Trail (Europe)

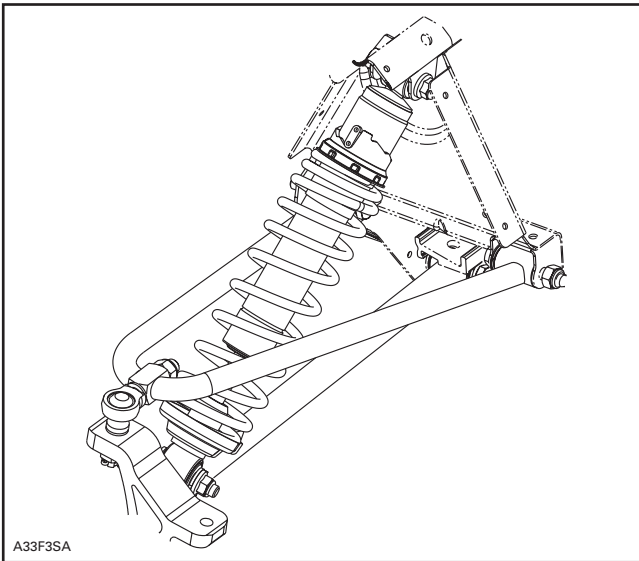

A33F3SA
GSX Limited
GTX Limited
GTX 600 HO SDI Sport (Europe)
MX Z Adrenaline
MX Z Renegade

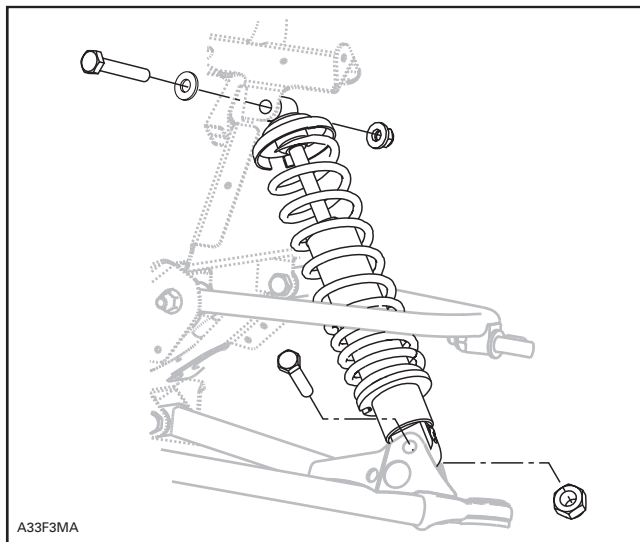

A33F3MA
GSX 380F/550F
GTX 380F/550F
MX Z 380F/550F
Summit 550F
Expedition Sport 550F

Section 10 STEERING/FRONT SUSPENSION

Subsection 02 (FRONT SUSPENSION)

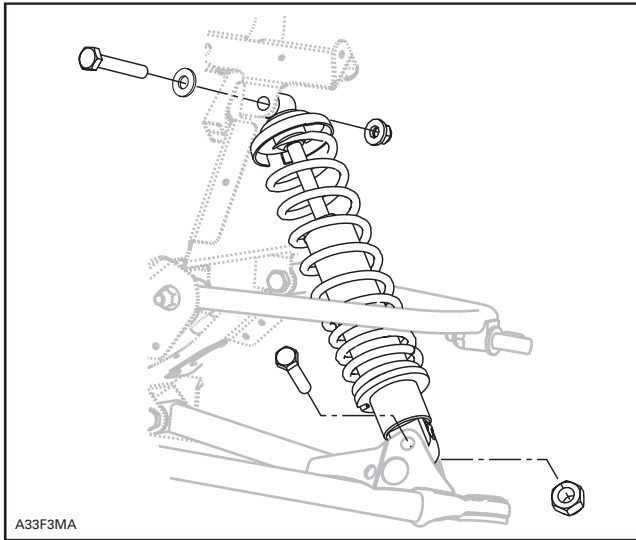

Summit X

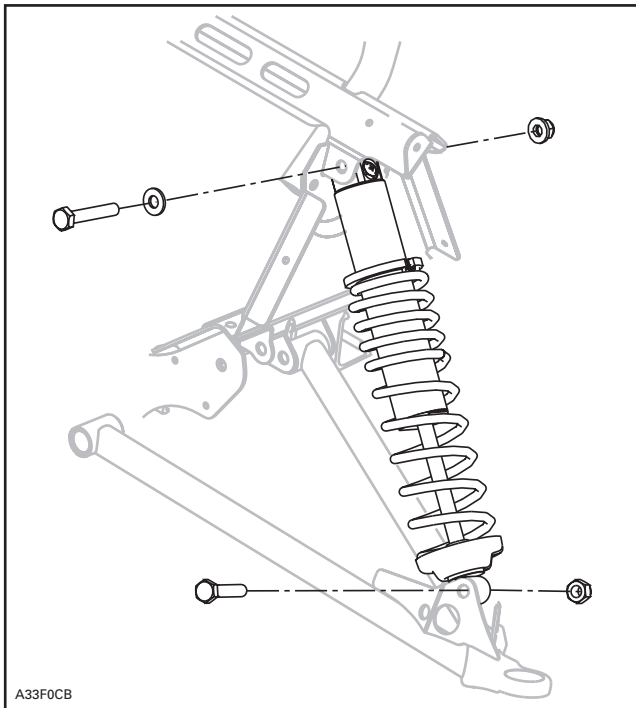

MX Z 380F (Europe)
MX Z Renegade (Europe)

Readjust spring preload.

Ski

Apply suspension synthetic grease (P/N 293 550 033) between bushing no. 28 and spacer no. 27 and also on inner tube of ski leg.

Summit Only

Install bushing no. 29 and spacer no. 30 inward on each ski leg for the wide ski stance. Install outward for narrow ski stance.

WARNING

Install skis with proper side facing inward. Refer to warning on ski.

Adjustment

All Models

Proceed with ski alignment. Refer to STEERING SYSTEM.

BODY

INSTALLATION AND ADJUSTMENT

DECAL

To remove a decal; heat old decal with a heat gun and peel off slowly.

Using isopropyl alcohol, clean the surface and dry thoroughly.

Apply liquid soap to new decal and carefully position the decal. Using a sponge or a squeegee, remove the air bubbles and surplus water working from the center toward the edges. Allow to air dry.

CAUTION: Do not apply isopropyl alcohol or solvent directly on decals. Use only in a well ventilated area.

WINDSHIELD

Pull windshield one side at a time as shown to remove it.



Remove protective film when installing a new windshield.

Apply liquid soap on grommets prior to installing windshield to ease pin insertion.

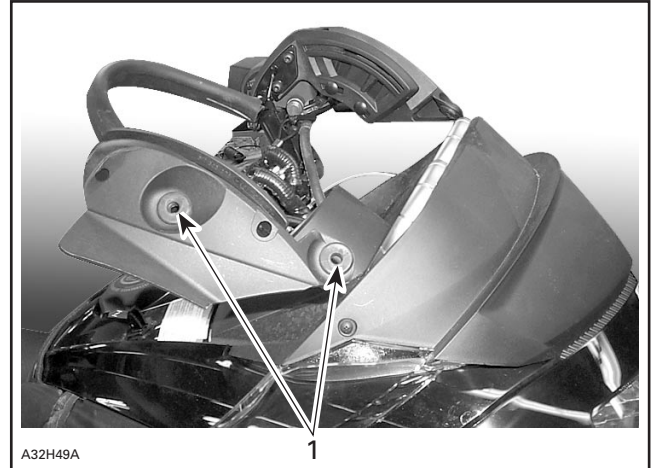

1. Grommets

Position the windshield on the windshield supports then push it down until the pins are fully inserted into the grommets.

GUARD

Disassembly and Assembly

NOTE: For additional information (e.g.: exploded view) refer to the correspondent *Parts Catalog*.

⚠ WARNING

Engine should be running only with guard well secured in place.

Inspection

Check guard mounting bosses, clips and retainers for wear.

WIRING HARNESS

⚠ WARNING

Ensure all terminals are properly crimped on the wires and that all connector housings are properly fastened. Keep wires away from any rotating, moving, heating and vibrating parts. Use proper fastening devices as required.

Section 11 BODY/FRAME

Subsection 01 (BODY)

CABLES

WARNING

Before installation, ensure that all cables are in perfect condition. Properly install the cable ends and secure them in place. Pay attention to route them properly, away from any rotating, moving, heating or vibrating parts.

TUBING

WARNING

Always ensure that the fuel, vent, primer, impulse, injection oil and rotary valve oil lines are properly fixed to their connectors, that they are not perforated or kinked and that they are properly routed away from any rotating, moving, heating or vibrating parts. Also check for leaks. Replace if required.

NOTE: Refer to proper *Parts Catalog* to find suitable clip part numbers.

PLASTIC MAINTENANCE AND REPAIR

MAINTENANCE

Clean the vehicle thoroughly, removing all dirt and grease accumulation.

To clean use a soft clean cloth and either soapy water or isopropyl alcohol.

To remove grease, oil or glue use isopropyl alcohol.

CAUTION: Do not apply isopropyl alcohol or acetone directly on decals.

CAUTION: The following products must not be used to clean or wax any of the plastic components used on the vehicles:

- gasoline
- brake fluid
- kerosene
- diesel fuel
- lighter fluid
- varsol
- naphtha
- acetone

- strong detergents
- abrasive cleaners
- waxes containing an abrasive or a cleaning agent in their formula.

Apply wax on glossy finish only. Protect the vehicle with a cover to prevent dust accumulation during storage.

CAUTION: If for some reason the snowmobile has to be stored outside, it is preferable to cover it with an opaque tarpaulin. This will prevent the sun rays from affecting the plastic components and the vehicle finish.

REPAIR

The very first step before repairing plastic materials is to find out exactly which type of material is involved.

CAUTION: Some repair products are not compatible with certain plastics.

WARNING

Polycarbonate windshields must never be repaired by welding or otherwise.

For hood repair, refer to a specialized shop.

The following company provides a complete line of products to repair plastic materials:

CREST INDUSTRIES, INC. TRENTON, MI 48183	PHONE: (734) 479-4141 TOLL FREE: 1 800 822-4100 FAX: 734-479-4040 E-MAIL: INFO@CRESTAUTO.COM WWW.CRESTAUTO.COM
---	--

FRAME

SERVICE TOOLS

Description	Part Number	Page
Supertanium drill bit.....	529 031 800	463

SERVICE PRODUCTS

Description	Part Number	Page
XP-S synthetic chaincase oil.....	413 803 300	463

FRAME CLEANING

NOTE: For bare aluminum frames use only aluminum cleaner and follow instructions on container. (Dursol cleaner or equivalent).

Clean frame and tunnel with appropriate cleaners and rinse with high pressure hose.

CAUTION: Never direct high-pressure water jet towards decals. They will peel off.

Touch up all metal spots where paint has been scratched off. Spray all bare metal parts of vehicle with metal protector.

Seat Cleaning

For all models, it is recommend to clean the seat with a solution of **warm soapy water**, using a soft clean cloth.

CAUTION: Avoid use of harsh detergents such as strong soaps, degreasing solvents, abrasive cleaners, paint thinners, etc., that may cause damage to the seat cover.

FRAME WELDING

Aluminum Frame

- No welds should be done on aluminum frame except if mentioned or required on a BRP *bulletin*.
- Use ER-5356 rods for MIG or TIG welding.

CAUTION: Before performing electrical welding anywhere on the vehicle, unplug electronic module. On models equipped with a battery, also unplug the negative cable. This will protect the electronic module and battery against damage caused by flowing current when welding.

CAUTION: If welding is to be done near plastic material, it is recommended to either remove the part from the area or to protect it with aluminum foil to prevent damage.

FRAME COMPONENT REPLACEMENT

Drilling Procedure

When drilling self-piercing rivets, use the Supertanium drill bit (P/N 529 031 800), available in a 5 mm (3/16 in) size and shipped in packs of 2.

For proper drilling instructions and to prevent premature wear, follow the procedure below.

Always use a variable speed drill.

Partially drill rivet end — not the rivet head.

Maintain a slow to medium speed at all times when drilling. The proper speed is attained when a constant chip is ejected.

NOTE: To increase bit life, use XP-S synthetic chaincase oil (P/N 413 803 300) as a cutting oil.

CAUTION: High speed drilling will cause excessive heat which may destroy the cutting edge of the bit; therefore, avoid using pneumatic drills.

Section 11 BODY/FRAME

Subsection 02 (FRAME)

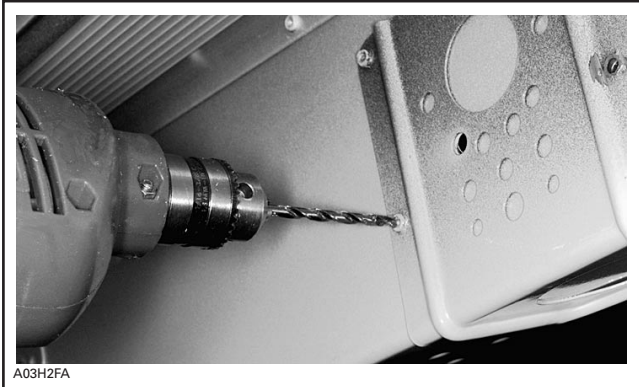

TYPICAL

Cut rivet using a chisel.

Remove riveted part.

Drive out remaining rivet head using a punch.

Section 12 TECHNICAL DATA
Subsection 01 (FAN COOLED MODELS)

FAN COOLED MODELS

MODEL		GSX/GTX/MX Z	EXPEDITION/SUMMIT/ GSX/GTX/MX Z
		380 F	550 F
ENGINE			
Engine type		377	552
Number of cylinder		2	
Bore	Standard mm (in)	62 (2.441)	76 (2.992)
Stroke mm (in)		61.00 (2.402)	
Displacement cm ³ (in ³)		368.30 (22.475)	553.40 (33.771)
Compression ratio		11.2 ± 0.5	9.6 ± 0.5
Maximum power engine speed (1) ± 100 RPM		7000	
Piston ring type	1 st	Semi-trapezoidal	
	2 nd	Rectangular	
Ring end gap	New mm (in)	0.20 to 0.35 (.008 to .0138)	0.40 to 0.55 (.016 to .022)
	Wear limit mm (in)	1.0 (.039)	
Ring/piston groove clearance	New mm (in)	0.040 to 0.110 (.0016 to .0043)	0.04 to 0.08 (.0016 to .0030)
	Wear limit mm (in)	0.2 (.0079)	
Piston/cylinder wall clearance	New mm (in)	0.070 ± 0.016 (.0028 ± .0006)	0.147 ± 0.026 (.0058 ± .0010)
	Wear limit mm (in)	0.2 (.0079)	
Maximum crankshaft end play (2)	New mm (in)	0.3 (.012)	
Maximum crankshaft deflection at PTO	Wear limit mm (in)	0.06 (.0024)	
Connecting rod big end axial play	New mm (in)	0.200 to 0.527 (.0079 to .0207)	
	Wear limit mm (in)	1.2 (.0472)	
ELECTRICAL			
Magneto generator output		340 W	
Ignition type		CDI	
Spark plug	Make and type	NGK BR9ES (6)	
	Gap mm (in)	0.40 to 0.50 (.016 to .020)	
Ignition timing BTDC (3) mm (in)		2.79 (.110)	2.77 (.109)
Trigger coil (4) Ω		160 to 180	
Generating coil (4)	Low speed Ω	6.3	
	High speed Ω	7.7	
Lighting coil (4) Ω		0.145 to 0.175	
High tension coil (4)	Primary	N.A.	
	Secondary	N.A.	
Battery		12 V, 18 A•h (if applicable)	
Headlamp W		60/55 (H4)	
Taillight and stoplight W		8/27	
Tachometer and speedometer bulbs W		2 x 3	
Fuel and temperature gauge bulbs W		N.A.	
Fuse	Starter solenoid A	30 (if applicable)	
	Fuel level sensor A	N.A.	

Section 12 TECHNICAL DATA

Subsection 01 (FAN COOLED MODELS)

MODEL		GSX/GTX/MX Z	EXPEDITION/SUMMIT/ GSX/GTX/MX Z		
		380 F	550 F		
FUEL SYSTEM					
Carburetor type	EXPEDITION		—	VM34-617	
	GSX/GTX/MX Z		VM30-213	VM34-617	
	SUMMIT		—	VM34-616	
	SUMMIT (EUR)		—	VM34-617	
Main jet	EXPEDITION		—	260	
	GSX/GTX/MX Z		195	260	
	SUMMIT		—	220	
	SUMMIT (EUR)		—	260	
Needle jet		Q-2	P-7		
Pilot jet		35	45		
Needle identification	EXPEDITION		—	6BCY40-4	
	GSX/GTX/MX Z		6DEY13-3	6BCY40-4	
	SUMMIT		—	6BCY40-3	
	SUMMIT (EUR)		—	6BCY40-4	
Slide cut-away		2.0	2.5		
Float adjustment		mm (in)	23.90 ± 1 (.941 ± .040)		
Air or pilot screw adjustment		± 1/16 turn	N.A.		
Idle speed		± 200 RPM	1650		
Gas type		Unleaded			
Pump octane number	Inside North America	(R+M)/2	87 or higher		
	Outside North America	RON	91 or higher		
Gas/oil ratio		Injection			
Injection oil		XP-S mineral injection oil			
COOLING SYSTEM					
Type		Fan			
Axial fan belt adjustment	Deflection	mm (in)	9.5 ± 0.5 (.374 ± .020)		
	Force	kg (lbf)	5.0 (11.0)		
Thermostat opening temperature		N.A.			
Radiator cap opening pressure		N.A.			
DRIVE SYSTEM					
Chaincase Oil		XP-S synthetic chaincase oil			
Chain drive ratio	GSX/MX Z		19/45	19/43	
	GTX		19/45	21/45	
	GTX (EUR)		19/45	19/43	
	EXPEDITION/SUMMIT		—	19/43	
Chain	Pitch		in		3/8
	Type/links qty/plate qty	GSX/MX Z/ GTX (EUR)		Silent 74/13	Silent 72/13
		GTX		Silent 74/13	
		EXPEDITION/SUMMIT		—	Silent 72/13
Drive pulley Type		Bombardier Lite			

Section 12 TECHNICAL DATA
Subsection 01 (FAN COOLED MODELS)

MODEL			GSX/GTX/MX Z	EXPEDITION/SUMMIT/ GSX/GTX/MX Z
			380 F	550 F
Drive pulley calibration	Clutch engagement ± 100 RPM	GSX/MX Z	3300	3500
		GTX	3300	3000
		EXPEDITION/SUMMIT	—	3300
		SUMMIT (EUR)	—	3000
	Spring color	GSX/MX Z	Blue/Pink	Purple/Yellow
		GTX	Blue/Pink	Blue/Orange
		EXPEDITION/SUMMIT	—	Purple/Yellow
		SUMMIT (EUR)	—	Blue/Orange
	Spring length		—	
	Weight 417 120 400 = 21 g 417 114 400 = 3.4 g	EXPEDITION/ SUMMIT (EUR)	—	1 x 417 120 400 + 2 x 417 114 400
		GSX/GTX/MX Z	1 x 417 120 400 + 1 x 417 114 400	1 x 417 120 400 + 2 x 417 114 400
		SUMMIT	—	5 x 417 114 400
	Block	EXPEDITION/ SUMMIT (EUR)	—	3 x 417 128 932
		GSX/GTX/MX Z	3 x 417 128 605	3 x 417 128 932
		SUMMIT	—	3 x 415 128 968
	Cap		1 x 417 114 500	
	Pin		—	
Ramp		—		
Screw position		—		
Driven pulley	Type		Formula RER	
	Spring preload		N.A.	
	Cam angle		44°	
Pulley distance	Z	mm (in)	17.5 (0.689)	
Offset	X	mm (in)	33.4 ± 0.5 (1.315 ± 0.2)	
	Y – X	mm (in)	0.46 (.0181)	
Drive belt part number		P/N	415 060 600	
Drive belt	Width (10)	mm (in)	34.70 (1.366)	
	Wear limit	mm (in)	32.30 (1.272)	
Drive belt adjustment	Deflection	mm (in)	32 ± 5 (1.260 ± .197)	
	Force (8)	kg (lbf)	11.34 (25)	

Section 12 TECHNICAL DATA

Subsection 01 (FAN COOLED MODELS)

MODEL			GSX/GTX/MX Z	EXPEDITION/SUMMIT/ GSX/GTX/MX Z
			380 F	550 F
Track	Width	GSX/GTX/MX Z	381 mm (15 in)	
		SUMMIT	—	381 mm (15 in)
		EXPEDITION/ SUMMIT (EUR)	—	406 mm (16 in)
	Length	GSX/MX Z	3074 mm (121 in)	
		GTX	3456 mm (136 in)	
		EXPEDITION/SUMMIT	—	3456 mm (136 in)
	Profile height	GSX/MXZ	18.4 mm (.724 in)	22.3 mm (.878 in)
		MX Z (EUR)	25.4 mm (1.0 in)	31.8 mm (1.25 in)
		GTX	18.4 mm (.724 in)	22.3 mm (.878 in)
		GTX (EUR)	22.3 mm (.878 in)	22.3 mm (.878 in)
		EXPEDITION/ SUMMIT (EUR)	—	31.8 mm (1.25 in)
SUMMIT		—	38.1 mm (1.50 in)	
Track adjustment	Deflection mm (in)		30 to 35 (1-3/16 to 1-3/8)	
	Force (9) kg (lbf)		7.3 (16)	
Suspension type	Track	GSX/MX Z	SC 3 121 in	
		GTX	SC-136 in	
		EXPEDITION/SUMMIT	—	SC-136 in
	Ski	R.A.S. A-Arm		
BRAKE				
Brake fluid reservoir			mL (U.S. oz)	60 (2.0)
Brake fluid			GTLMA (DOT 4) (P/N 293 600 062) Racing brake fluid SRF (DOT 4) (P/N 293 600 063)	
VEHICLE INFORMATIONS				
Mass (dry)	EXPEDITION	Manual start	—	208 kg (458 lb)
		Electric start	—	220 kg (484 lb)
	GSX	Electric start	200 kg (440 lb)	209 kg (460 lb)
		Electric start	210 kg (462 lb)	220 kg (484 lb)
	MX Z	Manual start	186 kg (409 lb)	195 kg (429 lb)
	SUMMIT	Manual start	—	200 kg (440 lb)
Length	EXPEDITION		—	3072 mm (121 in)
	GSX/MX Z		2830 mm (111 in)	
	GTX		3072 mm (121 in)	
	SUMMIT		—	3045 mm (120 in)
Width	EXPEDITION		—	1150 mm (45.2 in)
	GSX/GTX/MX Z		1150 mm (45.2 in)	
	SUMMIT		—	1139 mm (44.8 in)
Height	EXPEDITION		—	1230 mm (48.4 in)
	GSX		1160 mm (45.6 in)	
	GTX		1230 mm (48.4 in)	
	MX Z		1105 mm (43.5 in)	
	SUMMIT		—	1122 mm (44.1 in)

Section 12 TECHNICAL DATA
Subsection 01 (FAN COOLED MODELS)

MODEL		GSX/GTX/MX Z	EXPEDITION/SUMMIT/ GSX/GTX/MX Z
		380 F	550 F
Ski stance (carbide to carbide)	mm (in)	1080 (42.5)	
Toe-out	mm (in)	0.00	
Camber		0°	
Ground contact area	EXPEDITION	—	7968 cm ² (1235 in ²)
	GSX/MX Z	6947 cm ² (1077 in ²)	
	GTX	7633 cm ² (1183 in ²)	
	SUMMIT	—	8210 cm ² (1273 in ²)
	SUMMIT (EUR)	—	8545 cm ² (1324 in ²)
Ground contact pressure	EXPEDITION	—	2.56 kPa (.371 PSI)
	GSX	2.82 kPa (.409 PSI)	2.95 kPa (.428 PSI)
	GTX	2.70 kPa (.392 PSI)	2.83 kPa (.410 PSI)
	MX Z	2.63 kPa (.381 PSI)	2.75 kPa (.399 PSI)
	SUMMIT	—	2.39 kPa (.347 PSI)
	SUMMIT (EUR)	—	2.30 kPa (.334 PSI)
Frame material		Aluminum	
Bottom pan material		Impact Copolymer	
Hood material		Surllyn	
Side Panels		Polypropylene	
CAPACITIES			
Fuel tank	L (U.S. gal)	40 (10.6)	
Chaincase/gearbox	mL (U.S. oz)	250 (8.5)	
Cooling system	L (U.S. oz)	N.A.	
Injection oil reservoir	L (U.S. oz)	3.5 (118.4)	
TIGHTENING TORQUE (engine cold)			
Drive pulley retaining screw		(5)	
Exhaust manifold nuts or bolts		22 N•m (16 lbf•ft)	
Magneto ring nut		105 N•m (77 lbf•ft)	
Crankcase nuts or screws	M6	N.A.	
	M8	22 N•m (16 lbf•ft)	
Crankcase/engine support nuts or screws		40 N•m (30 lbf•ft)	
Cylinder head screws		22 N•m (16 lbf•ft)	
Crankcase/cylinder nuts or screws		N.A.	
Axial fan shaft nut		48 N•m (35 lbf•ft)	

Section 12 TECHNICAL DATA
Subsection 02 (LIQUID COOLED MODELS)

LIQUID COOLED MODELS

MODEL		GSX/GTX/MX Z	GSX/GTX/MX Z/SUMMIT	
		500 SS	600 HO	800 HO
ENGINE				
Engine type		593	593 HO	793 HO
Number of cylinder		2		
Bore	Standard mm (in)	76 (2.992)	72 (2.835)	82 (3.228)
Stroke	mm (in)	65.80 (2.591)	73 (2.874)	75.70 (2.980)
Displacement	cm ³ (in ³)	597.00 (36.431)	594.40 (36.273)	799.50 (48.789)
Compression ratio		12.00 ± 0.5	12.25 ± 0.5	12.00 ± 0.5
Maximum power engine speed (1)	593/593 HO/793 HO	8000 ± 100 RPM		7850 ± 100 RPM
	793 HO Power TEK	N.A.	N.A.	7950 ± 100 RPM
Piston ring type	1 st	Semi-trapezoidal		
	2 nd	—		
Ring end gap	New mm (in)	0.40 to 0.55 (.016 to .022)		
	Wear limit mm (in)	1.0 (.039)		
Ring/piston groove clearance	New mm (in)	0.04 to 0.09 (.0016 to .0035)	0.05 to 0.1 (.0020 to .0039)	
	Wear limit mm (in)	0.2 (.0079)		
Piston/cylinder wall clearance	New mm (in)	0.120 ± 0.016 (.0047 ± .0006)	0.105 ± 0.013 (.0041 ± .0005)	0.125 ± 0.022 (.0049 ± .0009)
	Wear limit mm (in)	0.20 (.0079)	0.18 (.0071)	0.20 (.0079)
Maximum crankshaft end play (2)	New mm (in)	0.3 (.012)		
Maximum crankshaft deflection at PTO	Wear limit mm (in)	0.06 (.0024)		
Connecting rod big end axial play	New mm (in)	0.390 to 0.737 (.0154 to .0290)	0.310 to 0.677 (.0122 to .0267)	
	Wear limit mm (in)	1.2 (.0472)		
ELECTRICAL				
Magneto generator output		360 W		
Ignition type		CDI		
Spark plug	Make and type	NGK BR9ECS (6)		
	Gap mm (in)	0.40 to 0.50 (.016 to .020)		
Ignition timing BTDC (3) (7)	mm (in)	2.49 (.0980)	2.79 (.110)	2.37 (.0933)
Trigger coil (4)	Ω	190 to 300		
Generating coil (4)	Low speed Ω	—		
	High speed Ω	—		
Lighting coil (4)	Ω	0.1 to 1.0		
High tension coil (4)	Primary	—		
	Secondary	—		

Section 12 TECHNICAL DATA

Subsection 02 (LIQUID COOLED MODELS)

MODEL		GSX/GTX/MX Z	GSX/GTX/MX Z/SUMMIT	
		500 SS	600 HO	800 HO
ELECTRICAL				
Battery		12 V, 18 A•h (if applicable)		
Headlamp	W	60/55 (H4)		
Taillight and stoplight	W	8/27		
Tachometer and speedometer bulbs	W	2 x 3		
Fuel and temperature gauge bulbs	W	—		
Fuse	Starter solenoid	A	30 (if applicable)	
	Fuel level sensor	A	—	
FUEL SYSTEM				
Carburetor type	GSX/GTX/MX Z	TM40 – B313	TM40 – B316	TM40–B319
	SUMMIT	—	TM40 – B325	TM40 – B328
	793 HO Power TEK (GSX/GTX/MX Z)	N.A.	N.A.	TM40–B322
Main jet	GSX/GTX/MX Z/SUMMIT	360	380	400
	793 HO Power TEK (GSX/GTX/MX Z)	N.A.	N.A.	440
Needle jet		P-0M		
Pilot jet		17.5		
Needle identification	GSX/GTX/MX Z	9DGM15–58	9DH114–58	9DG116–58
	SUMMIT	—	9DGK11–58	9EGY2–58
	793 HO Power TEK (GSX/GTX/MX Z)	N.A.	N.A.	9EG104–58
Clip position	GSX/GTX/MX Z	1		
	SUMMIT	—	3	
	793 HO Power TEK (GSX/GTX/MX Z)	N.A.	N.A.	—
Slide cut-away		2.0		
Float adjustment	mm (in)	—		
Air or pilot screw adjustment	± 1/16 turn	1.5		
Idle speed	± 200 RPM	1600		1500
Gas type	GSX/GTX/MX Z	Unleaded		
	SUMMIT	—	Unleaded	Premium unleaded
Pump octane number	Inside North America (R+M)/2	87 or higher (SUMMIT 800 HO: 91)		
	Outside North America RON	91 or higher (SUMMIT 800 HO: 95)		
Gas/oil ratio		Injection		
Injection oil		XP-S mineral injection oil		
COOLING SYSTEM				
Type		Liquid		
Coolant	Mixture	Ethyl glycol/water mix (50% coolant, 50% distilled water). Use coolant specifically designed for aluminum engines.		
	Premix	P/N 219 700 362 — 12 x 1 L		
Thermostat opening temperature	°C (°F)	42 (108)		
Radiator cap opening pressure	kPa (PSI)	90 (13)		

Section 12 TECHNICAL DATA
Subsection 02 (LIQUID COOLED MODELS)

MODEL		GSX/GTX/MX Z	GSX/GTX/MX Z/SUMMIT		
		500 SS	600 HO	800 HO	
DRIVE					
Chaincase oil		XP-S Synthetic chaincase oil			
Chain drive ratio	GSX	22/43		23/43	
	GTX	21/43		23/45	
	MX Z	Adrenaline	22/43		25/45
		Ren./Ren. X	—	21/43	23/43
		Trail	22/43	22/43	—
		Trail (EUR)	21/43	—	—
	SUMMIT	Adrenaline/X	—	19/45	
		Adrenaline (EUR)	—	19/45	21/45
Chain	Pitch	in		3/8	
	Type/links qty/plate qty	GSX	Silent 74/13		
		GTX	Silent 74/13		Silent 76/13
		MX Z (Adr./Trail)	Silent 74/13		Silent 76/13
		MX Z (Ren./Ren. X)	—	Silent 74/13	
		SUMMIT	—	Silent 74/13	
Drive pulley type		TRA III			
Drive pulley calibration	Clutch engagement ± 100 RPM	MX Z	3800		
		GSX	3400	3800	3600
		GTX	3400	3800	
		SUMMIT	—	3600	3800
	Spring color	MX Z	Green/White	Purple/Blue	Violet/Green
		GSX/GTX	Purple/Pink	Purple/Blue	Blue/Green
		SUMMIT	—	Purple/White	Violet/Yellow
	Spring length	MX Z	110.7 mm (4.358 in)	114.6 mm (4.5 in)	133.5 mm (5.256 in)
		GSX/GTX	101.8 mm (4.008 in)	114.6 mm (4.5 in)	105.7 mm (4.161 in)
		SUMMIT	—	98.5 mm (3.878 in)	157.9 mm (6.217 in)
	Weight	—			
	Block	—			
	Cap	—			
	Pin (with roller (P/N 417 003 900))	GSX/GTX/MX Z	Solid (P/N 417 004 308)		Solid (P/N 417 222 594)
		SUMMIT	—	Solid (P/N 417 222 478)	Solid (P/N 417 222 707)
		SUMMIT (EUR)	—	Solid (P/N 417 004 308)	
	Ramp	GSX/GTX/MX Z	412	410	414
		793 HO Power TEK (GSX/GTX/MX Z)	N.A.	N.A.	415
		SUMMIT	—	417	415
		SUMMIT (EUR)	—	410	415
Screw position	MX Z	3			
	GSX/GTX	4	3		
	SUMMIT	—	1		
	SUMMIT (EUR)	—	3		

Section 12 TECHNICAL DATA
Subsection 02 (LIQUID COOLED MODELS)

MODEL		GSX/GTX/MX Z		GSX/GTX/MX Z/SUMMIT		
		500 SS		600 HO	800 HO	
DRIVE						
Driven pulley type	Type	HPV VSA				
	Spring preload	0				
	Cam angle	GSX	44°	47°/44°	50°/40°	
		GTX	44°	47°/44°	47°/40°	
		MX Z (Adrenaline)	44°	47°/44°	50°/40°	
		MX Z (Ren./Ren. X)	—	44°	47°/40°	
		MX Z (Trail)	44°	47°/44°	—	
		SUMMIT (Adr.)	—	47°/44°	44°	
		SUMMIT (Adr. 144")	—	47°/44°		
		SUMMIT (EUR)	—	44°		
SUMMIT (X)	—	—	44°			
SUMMIT (X 144")	—	—	47°/44°			
Pulley distance	Z	mm (in)	19.0 (.748)	20.0 (.787)		
Offset	X	mm (in)	37.0 ± 0.5 (1.457 ± 0.2)			
	Y – X	mm (in)	0.82 (.0032)			
Drive belt part number	P/N		417 300 197		417 300 166	
Drive belt	Width (10)	mm (in)	37.3 (1.327)		37.7 (1.484)	
	Wear limit	mm (in)	34.9 (1.374)		35.3 (1.390)	
Drive belt adjustment	Deflection	mm (in)	32 ± 5 (1.260 ± .197)			
	Force (8)	kg (lbf)	11.30 (24.91)			
Track (width)	GSX/GTX	381 mm (15 in)				
	MX Z (Adrenaline)	381 mm (15 in)				
	MX Z (Ren./Ren. X)	—	406 mm (16 in)			
	MX Z (Trail)	381 mm (15 in)		—		
	SUMMIT	—	406 mm (16 in)			
Track (length)	GSX	3074 mm (121 in)				
	GTX	3456 mm (136 in)				
	MX Z (Adrenaline)	3074 mm (121 in)				
	MX Z (Ren./Ren. X)	—	3456 mm (136 in)			
	MX Z (Trail)	3074 mm (121 in)		—		
	SUMMIT (Adr.)	—	3648 mm (144 in)			
		—	—	3840 mm (151 in)		
	SUMMIT (X)	—	—	3648 mm (144 in)		
—		—	3840 mm (151 in)			
			—	4038 mm (159 in)		

Section 12 TECHNICAL DATA
Subsection 02 (LIQUID COOLED MODELS)

MODEL		GSX/GTX/MX Z		GSX/GTX/MX Z/SUMMIT		
		500 SS		600 HO	800 HO	
DRIVE						
Track (profile height)		GSX	25.4 mm (1.0 in)			
		GTX	22.3 mm (.878 in)			
		GTX (EUR)	31.8 mm (1.25 in)	—	31.8 mm (1.25 in)	
		MX Z (Adrenaline)	25.4 mm (1.0 in)			
			31.8 mm (1.25 in)			
		MX Z (Ren./Ren. X)	—	31.8 mm (1.25 in)		
			—	—	44.5 mm (1.75 in)	
		MX Z (Trail)	25.4 mm (1.0 in)	25.4 mm (1.0 in)	—	
		MX Z (Trail EUR)	31.8 mm (1.25 in)	31.8 mm (1.25 in)	—	
		SUMMIT (Adr.)	—	50.8 mm (2.0 in)		
SUMMIT (X)	—	—	50.8 mm (2.0 in)			
	—	—	57.2 mm (2.25 in)			
Track adjustment		Adjustment Deflection mm (in)		30 to 35 (1.181 to 1.378)		
		Force (9) kg (lbf)		7.3 (16)		
Suspension type		Track	GSX	SC 3 121 in		
			GTX	SC 3 136 in		
			MX Z (Adrenaline)	SC 3 121 in		
			MX Z (Ren./Ren. X)	—	SC 3 136 in	
			MX Z (Trail)	SC 3 121 in		—
			SUMMIT (Adr.)	SC 144 in		
				—	—	SC 151 in
			SUMMIT (X)	—	—	SC 144 in
		—		—	SC 151 in	
Ski		R.A.S. A-arm				
BRAKE						
Brake fluid reservoir		mL (U.S. oz)		60 (2.0)		
Brake fluid (P/N)		GTLMA (DOT 4) (P/N 293 600 062) Racing brake fluid SRF (DOT 4) (P/N 293 600 063)				

Section 12 TECHNICAL DATA

Subsection 02 (LIQUID COOLED MODELS)

MODEL		GSX/GTX/MX Z		GSX/GTX/MX Z/SUMMIT		
		500 SS		600 HO	800 HO	
VEHICLE INFORMATION						
Mass (dry)	GSX	Electric start	222 kg (488 lb)	225 kg (495 lb)	225 kg (495 lb)	
	GTX	Electric start	231 kg (508 lb)	233 kg (513 lb)	238 kg (524 lb)	
	MX Z (Adrenaline)	Manual start	209 kg (460 lb)	211 kg (464 lb)		
		Electric start	220 kg (484 lb)	223 kg (491 lb)		
	MX Z (Ren./Ren. X)	Manual start	—	218 kg (480 lb)		
		Electric start	—	230 kg (506 lb)		
	MX Z (Trail)	Manual start	209 kg (460 lb)	211 kg (464 lb)	—	
		Electric start	220 kg (484 lb)	223 kg (491 lb)	—	
	SUMMIT (Adrenaline)	144 in Manual start	—	222 kg (488 lb)		
		151 in Manual start	—	—	224 kg (493 lb)	
	SUMMIT (X)	144 in Manual start	—	—	222 kg (488 lb)	
		144 in Electric start	—	—	234 kg (515 lb)	
		151 in Manual start	—	—	224 kg (493 lb)	
		151 in Electric start	—	—	236 kg (519 lb)	
		159 in Manual start	—	—	226 kg (497 lb)	
		159 in Electric start	—	—	238 kg (524 lb)	
Length	GSX		2882 mm (113.464 in)			
	GTX		3072 mm (120.945 in)			
	MX Z	Adrenaline	2882 mm (113.464 in)			
		Renegade	—	3055 mm (120.276 in)		
		Trail	2882 mm (113.464 in)		—	
	SUMMIT (Adrenaline)	144 in	—	3125 mm (123.031 in)		
		151 in	—	—	3216 mm (126.614 in)	
	SUMMIT (X)	144 in	—	—	3125 mm (123.031 in)	
		151 in	—	—	3216 mm (126.614 in)	
		159 in	—	—	3825 mm (150.591 in)	
Width	GSX/GTX/MX Z		1217 mm (48 in)			
	SUMMIT		—	1139 mm (45 in)		
Height	GSX		1160 mm (45.669 in)			
	GTX		1230 mm (48.425 in)			
	MX Z		1105 mm (43.5 in)			
	MX Z (Renegade X)		—	—	1022 mm (40 in)	
	SUMMIT		—	1122 mm (44 in)		
Ski stance (carbide to carbide)	GSX/GTX/MX Z		1195 mm (47 in)			
	SUMMIT		—	1080 mm (42.520 in)		

Section 12 TECHNICAL DATA
Subsection 02 (LIQUID COOLED MODELS)

MODEL		GSX/GTX/MX Z		GSX/GTX/MX Z/SUMMIT		
		500 SS		600 HO	800 HO	
VEHICLE INFORMATION						
Toe-out		mm (in)		0.00		
Camber				0°		
Ground contact area	GSX		6910.2 cm ² (1071 in ²)			
	GTX		7596 cm ² (1177.382 in ²)			
	MX Z	Adrenaline		6910.2 cm ² (1071 in ²)		
		Renegade		—	7931.3 cm ² (1229 in ²)	7926 cm ² (1229 in ²)
		Renegade X		—	—	7931.3 cm ² (1229 in ²)
		Trail		6910.2 cm ² (1071 in ²)		—
	SUMMIT (Adrenaline)	144 in	—	—	9049.86 cm ² (1402.731 in ²)	
		151 in	—	—	—	9537.54 cm ² (1478.322 in ²)
	SUMMIT (X)	144 in	—	—	—	9049.86 cm ² (1402.731 in ²)
		151 in	—	—	—	9537.54 cm ² (1478.322 in ²)
		159 in	—	—	—	10025.22 cm ² (1553.912 in ²)
	Ground contact pressure	GSX		Electric start	3.15 kPa (.457 PSI)	3.19 kPa (.463 PSI)
GTX		Electric start	2.98 kPa (.432 PSI)	3.01 kPa (.436 PSI)	3.07 kPa (.445 PSI)	
MX Z (Adrenaline)		Manual start		2.97 kPa (.431 PSI)	3.00 kPa (.435 PSI)	
		Electric start		3.12 kPa (.452 PSI)	3.17 kPa (.460 PSI)	3.00 kPa (.435 PSI)
MX Z (Ren./Ren. X)		Manual start		—	2.70 kPa (.392 PSI)	
		Electric start		—	2.84 kPa (.412 PSI)	
MX Z (Trail)		Manual start		2.97 kPa (.431 PSI)	3.00 kPa (.435 PSI)	—
		Electric start		3.12 kPa (.452 PSI)	3.17 kPa (.460 PSI)	—
SUMMIT (Adrenaline)		144 in Manual start		—	2.41 kPa (.349 PSI)	
		151 in Manual start		—	—	2.30 kPa (.334 PSI)
SUMMIT (X)		144 in Manual start		—	—	2.41 kPa (.349 PSI)
		144 in Electric start		—	—	2.54 kPa (.368 PSI)
		151 in Manual start		—	—	2.30 kPa (.334 PSI)
		151 in Electric start		—	—	2.43 kPa (.352 PSI)
	159 in Manual start		—	—	2.21 kPa (.320 PSI)	
	159 in Electric start		—	—	2.33 kPa (.338 PSI)	
Frame material		Aluminum				
Bottom pan material		Impact resistant copolymer				
Hood material		Surlyn				

Section 12 TECHNICAL DATA

Subsection 02 (LIQUID COOLED MODELS)

MODEL		GSX/GTX/MX Z	GSX/GTX/MX Z/SUMMIT		
		500 SS	600 HO	800 HO	
CAPACITIES					
Fuel tank		L (U.S. gal)	40 (10.6)		
Chaincase/gearbox		mL (U.S. oz)	250 (8.5)		
Cooling system	GSX		4.9 L (165.7 U.S. oz)		
	GTX		5.17 L (174.8 U.S. oz)		
	MX Z	Adrenaline	4.9 L (165.7 U.S. oz)		
		Ren./Ren. X	—	5.17 L (174.8 U.S. oz)	
		Trail	4.9 L (165.7 U.S. oz)		—
	SUMMIT (Adrenaline)	144 in	—	4.59 L (152.2 U.S. oz)	
		151 in	—	—	4.9 L (165.7 U.S. oz)
	SUMMIT (X)	144 in	—	—	4.59 L (152.2 U.S. oz)
		151 in	—	—	4.9 L (165.7 U.S. oz)
		159 in	—	—	4.69 L (158.6 U.S. oz)
Injection oil reservoir		3.5 L (118 U.S. oz)			
TIGHTENING TORQUE (engine cold)					
Drive pulley retaining screw		(5)			
Exhaust manifold nuts or bolts		22 N•m (16 lbf•ft)			
Magneto ring nut		125 N•m (92 lbf•ft)			
Crankcase nuts or screws	M6	9 N•m (80 lbf•in)			
	M8	29 N•m (21 lbf•ft)			
Crankcase/engine support nuts or screws		35 N•m (26 lbf•ft)			
Cylinder head screws		29 N•m (21 lbf•ft)			
Crankcase/cylinder nuts or screws		40 N•m (30 lbf•ft)			
Axial fan shaft nut		N.A.			

Section 12 TECHNICAL DATA
Subsection 03 (LIQUID COOLED (SDI) MODELS)

LIQUID COOLED (SDI) MODELS

MODEL			GSX/GTX/MX Z
			600 HO SDI
ENGINE			
Engine type			593 HO
Number of cylinder			2
Bore	Standard	mm (in)	72 (2.835)
Stroke		mm (in)	73 (2.874)
Displacement		cm ³ (in ³)	594.40 (36.273)
Compression ratio			12.25 ± 0.5
Maximum power engine speed (1)		± 100 RPM	8100
Piston ring type		1 st	Semi-trapezoidal
		2 nd	—
Ring end gap	New	mm (in)	0.40 to 0.55 (.016 to .022)
	Wear limit	mm (in)	1.0 (.039)
Ring/piston groove clearance	New	mm (in)	0.05 to 0.1 (.0020 to .0039)
	Wear limit	mm (in)	0.2 (.0079)
Piston/cylinder wall clearance	New	mm (in)	0.105 ± 0.013 (.0041 ± .0005)
	Wear limit	mm (in)	0.18 (.0071)
Maximum crankshaft end play (2)	New	mm (in)	0.3 (.012)
Maximum crankshaft deflection at PTO	Wear limit	mm (in)	0.06 (.0024)
Connecting rod big end axial play	New	mm (in)	0.310 to 0.677 (.0122 to .0267)
	Wear limit	mm (in)	1.2 (.0472)
ELECTRICAL			
Magneto generator output			W
			480
Ignition type			Inductive
Spark plug	Make and type		NGK BR9ECS (6)
	Gap	mm (in)	0.75 to 0.85 (.0303 to .0327)
Ignition timing BTDC (3) (7)			mm (in)
			5.39 (.2122)
Trigger coil (4)			Ω
			190 to 290
Generating coil (4)	Low speed	Ω	—
	High speed	Ω	—
Lighting coil (4)			Ω
			0.175 to 0.180
High tension coil (4)	Primary		—
	Secondary		—
Battery			12 V, 18 A•h (if applicable)
Headlamp			W
			60/55 (H4)
Taillight and stoplight			W
			8/27
Tachometer and speedometer bulbs			W
			2 x 3
Fuel and temperature gauge bulbs			W
			3 (if applicable)
Fuse	Starter solenoid		A
	Fuel level sensor		A
			30 (if applicable)
			—

Section 12 TECHNICAL DATA

Subsection 03 (LIQUID COOLED (SDI) MODELS)

MODEL		GSX/GTX/MX Z		
		600 HO SDI		
FUEL SYSTEM				
Throttle body type		Dell'Orto		
Idle speed		± 200 RPM		
Gas type		Unleaded		
Pump octane number	Inside North America	(R+M)/2		
	Outside North America	RON		
Gas/oil ratio		Injection		
Injection oil		XP-S 2-stroke synthetic blend		
COOLING SYSTEM				
Type		Liquid		
Coolant	Mixture	Ethyl glycol/water mix (50% coolant, 50% distilled water). Use coolant specifically designed for aluminum engines.		
	Premix	P/N 219 700 362 — 12 x 1 L		
Thermostat opening temperature		°C (°F)		
Radiator cap opening pressure		kPa (PSI)		
DRIVE				
Chaincase oil		XP-S Synthetic chaincase oil		
Chain drive ratio	GTX		21/43	
	GSX/MX Z		22/43	
	MX Z	Adrenaline/Renegade/X		22/43
		Renegade (EUR)		21/43
		Renegade X (1.25 in track)		21/43
		Renegade X (1.75 in track)		19/43
Chain	Pitch		in	
	Type/links qty/plate qty	GSX		Silent 74/13
		GTX		Silent 74/13
		MX Z (Adrenaline/Renegade/X)		Silent 74/13
		MX Z (Renegade X, 1.25 in track)		Silent 74/13
		MX Z (Renegade X, 1.75 in track)		Silent 72/13
Drive pulley type		TRA III		
Drive pulley calibration	Clutch engagement		± 100 RPM	
	Spring color		Blue/Yellow	
	Spring length		115.1 mm (4.531 in)	
	Weight		—	
	Block		—	
	Cap		—	
	Pin (with roller (P/N 417 003 900))		Solid (P/N 417 004 308)	
	Ramp		410	
	Screw position		4	

Section 12 TECHNICAL DATA
Subsection 03 (LIQUID COOLED (SDI) MODELS)

MODEL			GSX/GTX/MX Z
			600 HO SDI
DRIVE			
Driven pulley type	Type		HPV VSA
	Spring preload		0
	Cam angle	GSX/GTX/MX Z (Adrenaline/X)	47°/44°
		MX Z (Renegade/Renegade X)	44°
Pulley distance	Z	mm (in)	20.0 (.787)
Offset	X	mm (in)	37.0 ± 0.5 (1.457 ± 0.2)
	Y – X	mm (in)	0.82 (.0032)
Drive belt part number	P/N		417 300 197
Drive belt	Width (10)	mm (in)	37.3 (1.327)
	Wear limit	mm (in)	34.9 (1.374)
Drive belt adjustment	Deflection	mm (in)	32 ± 5 (1.260 ± .197)
	Force (8)	kg (lbf)	11.30 (24.91)
Track (width)	GSX/GTX/MX Z (Adrenaline/X)		381 mm (15 in)
	MX Z (Renegade/Renegade X)		406.4 mm (16 in)
Track (length)	GSX/MX Z (Adrenaline/X)		3074 mm (121 in)
	GTX		3456 mm (136 in)
	MX Z (Renegade/Renegade X)		3456 mm (136 in)
Track (profile height)	GSX		25.4 mm (1.0 in)
	GTX		22.3 mm (.878 in)
	GTX (EUR)		31.8 mm (1.25 in)
	MX Z (Adrenaline/X)		25.4 mm (1.0 in)
			31.8 mm (1.25 in)
	MX Z (Renegade)		31.8 mm (1.25 in)
	MX Z (Renegade X, 1.25 in track)		31.8 mm (1.25 in)
MX Z (Renegade X, 1.75 in track)		44.5 mm (1.75 in)	
Track adjustment	Adjustment deflection	mm (in)	30 to 35 (1.181 to 1.378)
	Force (9)	kg (lbf)	7.3 (16)
Suspension type	Track	GSX/MX Z (Adrenaline)	SC 3 121 in
		GTX	SC 3 136 in
		MX Z (Renegade/Renegade X)	SC 3 136 in
		MX Z (X)	SC 4
	Ski		R.A.S. A-arm
BRAKE			
Brake fluid reservoir	mL (U.S. oz)		60 (2.0)
Brake fluid (P/N)	GTLMA (DOT 4) (P/N 293 600 062) Racing brake fluid SRF (DOT 4) (P/N 293 600 063)		

Section 12 TECHNICAL DATA

Subsection 03 (LIQUID COOLED (SDI) MODELS)

MODEL			GSX/GTX/MX Z
			600 HO SDI
VEHICLE INFORMATIONS			
Mass (dry)	GSX	Electric start	229 kg (504 lb)
	GTX (Sport)	Electric start	238 kg (524 lb)
	GTX (Limited)	Electric start	242 kg (532 lb)
	MX Z (Adrenaline/X)	Manual start	215 kg (473 lb)
		Electric start	227 kg (499 lb)
	MX Z (Renegade/Renegade X)	Manual start	222 kg (488 lb)
Electric start		234 kg (515 lb)	
Length	GSX		2882 mm (113.464 in)
	GTX	Sport	2882 mm (113.464 in)
		Sport (EUR)	3072 mm (120.945 in)
		Limited	3072 mm (120.945 in)
	MX Z	Adrenaline/X	2882 mm (113.464 in)
Renegade		3055 mm (120.276 in)	
Width			1217 mm (48 in)
Height	GSX		1160 mm (45.669 in)
	GTX	Sport	1160 mm (45.669 in)
		Sport (EUR)	1230 mm (48.425 in)
		Limited	1230 mm (48.425 in)
	MX Z	Adrenaline/Renegade	1105 mm (43.5 in)
Renegade X/X		1022 mm (40.236 in)	
Ski stance (carbide to carbide)			1195 mm (47 in)
Toe-out		mm (in)	0.00
Camber			0°
Ground contact area	GSX		6910.2 cm ² (1071 in ²)
	GTX	Sport	2566.8 cm ² (397.855 in ²)
		Sport (EUR)	7596 cm ² (1177.382 in ²)
		Limited	7596 cm ² (1177.382 in ²)
	MX Z	Adrenaline/X	6910.2 cm ² (1071 in ²)
Renegade/Renegade X		7931.3 cm ² (1229 in ²)	
Ground contact pressure	GSX	Electric start	3.25 kPa (.471 PSI)
	GTX (Sport)	Electric start	9.10 kPa (1.320 PSI)
	GTX (Limited)	Electric start	3.13 kPa (.454 PSI)
	MX Z (Adrenaline/X)	Manual start	3.05 kPa (.442 PSI)
		Electric start	3.22 kPa (.467 PSI)
	MX Z (Renegade/Renegade X)	Manual start	2.75 kPa (.399 PSI)
Electric start		2.89 kPa (.419 PSI)	
Frame material			Aluminum
Bottom pan material			Impact resistant copolymer
Hood material			Surlyn

Section 12 TECHNICAL DATA
Subsection 03 (LIQUID COOLED (SDI) MODELS)

MODEL		GSX/GTX/MX Z	
		600 HO SDI	
CAPACITIES			
Fuel tank	L (U.S. gal)	40 (10.6)	
Chaincase/gearbox	mL (U.S. oz)	250 (8.5)	
Cooling system	GSX	4.9 L (165.7 U.S. oz)	
	GTX	5.17 L (174.8 U.S. oz)	
	MX Z	Adrenaline/X	4.9 L (165.7 U.S. oz)
		Renegade/Renegade X	5.17 L (174.8 U.S. oz)
Injection oil reservoir		3.5 L (118 U.S. oz)	
TIGHTENING TORQUE (engine cold)			
Drive pulley retaining screw		(5)	
Exhaust manifold nuts or bolts		22 N•m (16 lbf•ft)	
Magneto ring nut		125 N•m (92 lbf•ft)	
Crankcase nuts or screws	M6	9 N•m (80 lbf•in)	
	M8	29 N•m (21 lbf•ft)	
Crankcase/engine support nuts or screws		35 N•m (26 lbf•ft)	
Cylinder head screws		29 N•m (21 lbf•ft)	
Crankcase/cylinder nuts or screws		40 N•m (30 lbf•ft)	
Axial fan shaft nut		N.A.	

Section 12 TECHNICAL DATA

Subsection 03 (LIQUID COOLED (SDI) MODELS)

TECHNICAL DATA LEGEND

BTDC:	Before Top Dead Center	(1)	The maximum horsepower RPM applicable on the vehicle. It may be different under certain circumstances and BRP reserves the right to modify it without obligation.
CDI:	Capacitor Discharge Ignition	(2)	Crankshaft end-play is not adjustable on these models. Specification is given for verification purposes only.
MAG:	Magneto	(3)	At 3500 RPM with headlamp turned on.
N.A.:	Not Applicable	(4)	All resistance measurements must be performed with parts at room temperature (approx. 20°C (68°F)). Temperature greatly affects resistance measurements.
P/N:	Part Number	(5)	Drive pulley retaining screw: torque to 80 to 100 N•m (59 to 74 lbf•ft), install drive belt, accelerate the vehicle at low speed (maximum 30 km/h (20 MPH)) and apply the brake; repeat 5 times. Retorque screw to 90 to 100 N•m (66 to 74 lbf•ft).
PTO:	Power Take Off	(6)	CAUTION: Do not attempt to adjust gap on spark plug BR 9 ECS. The specification is given for verification purpose only. If found out of specification, replace with a new one.
R.A.S.:	Response Angle Suspension	(7)	793 HO Power TEK: with TPS (Throttle positioning Sensor) disconnected. 995 SDI: with APS (Air pressure Sensor) disconnected.
RER:	Rotax Electronic Reverse	(8)	Force applied midway between pulleys to obtain specified tension deflection.
RPM:	Revolution Per Minute	(9)	Force or downward pull applied to track to obtain specified tension deflection.
TRA:	Total Range Adjustable	(10)	Minimum allowable width may not be less than 3.0 mm (1/8 in) of new drive belt.
VSA:	Variable Sheave Angle		
W:	Watt		

WIRING DIAGRAMS

SERVICE TOOLS

Description	Part Number	Page
connector crimping tool.....	529 035 909	494
crimper die.....	529 035 906	494

Wiring diagrams can be found at the end of this subsection.

WIRING DIAGRAM LEGEND

⚠ WARNING

Ensure all terminals are properly crimped on the wires and all connector housings are properly fastened.

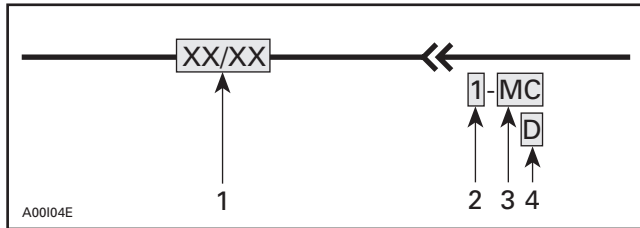

1. Wire colors
2. Connector housing area
3. Housing code per area
4. Wire connector location in housing

WIRE COLORS

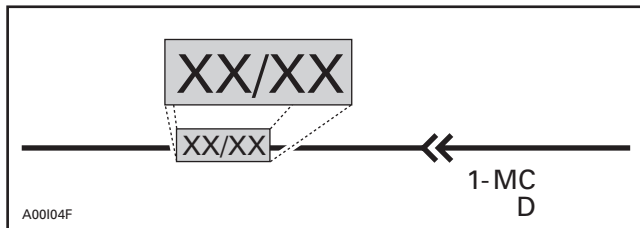

The first color of a wire is the main color, second color is the stripe.

Example: YL / BK is a YELLOW wire with a BLACK stripe.

COLOR CODE					
BE	—	BEIGE	OR	—	ORANGE
BK	—	BLACK	RD	—	RED
BU	—	BLUE	VI	—	VIOLET
BR	—	BROWN	WH	—	WHITE
GN	—	GREEN	YL	—	YELLOW
GY	—	GREY			

CONNECTOR HOUSING AREA

The first digit of the connector identification number presents the location of the connector on the vehicle.

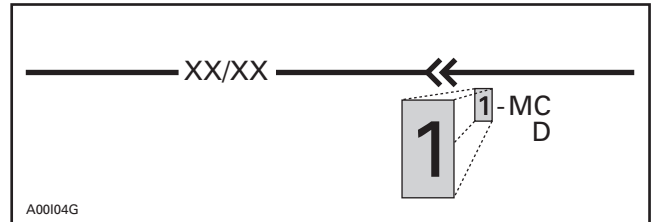

The following illustration shows the snowmobile with number on it. These numbers will correspond with the locations of the connector on the vehicle along with a brief description.

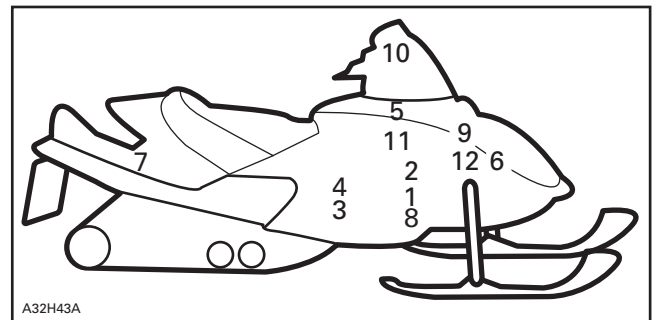

Section 13 WIRING DIAGRAM

Subsection 01 (WIRING DIAGRAMS)

AREA	LOCATION
1	Right hand side of engine
2	Engine
3	Near right hand side footrest
4	Near driven pulley
5	Under console
6	Under hood
7	Near fuel tank
8	Under engine
9	Near steering column or on primary air intake silencer
10	On handlebar
11	Injection oil tank
12	Secondary air intake silencer

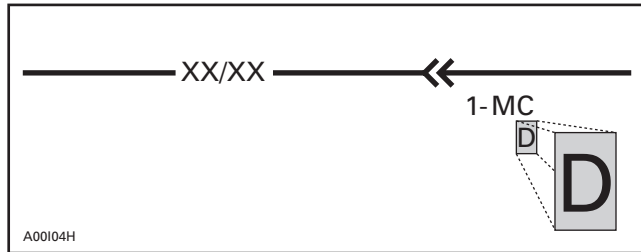

HOUSING REFERENCE PER AREA

The next two letters of the connector identification number represents a connector reference. If there are many connectors in the same area this helps identify which wire is in which connector.

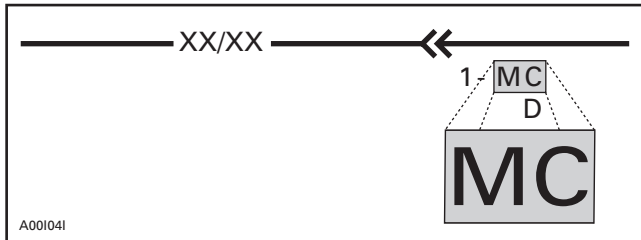

WIRE LOCATION IN CONNECTOR HOUSING

The third portion of the connector identification number represents the location of the wire in the connector housing. This could be identified by either a number such as 1, 2, 3 or by a letter such as A, B, C depending on the type of connector used.

Section 13 WIRING DIAGRAM



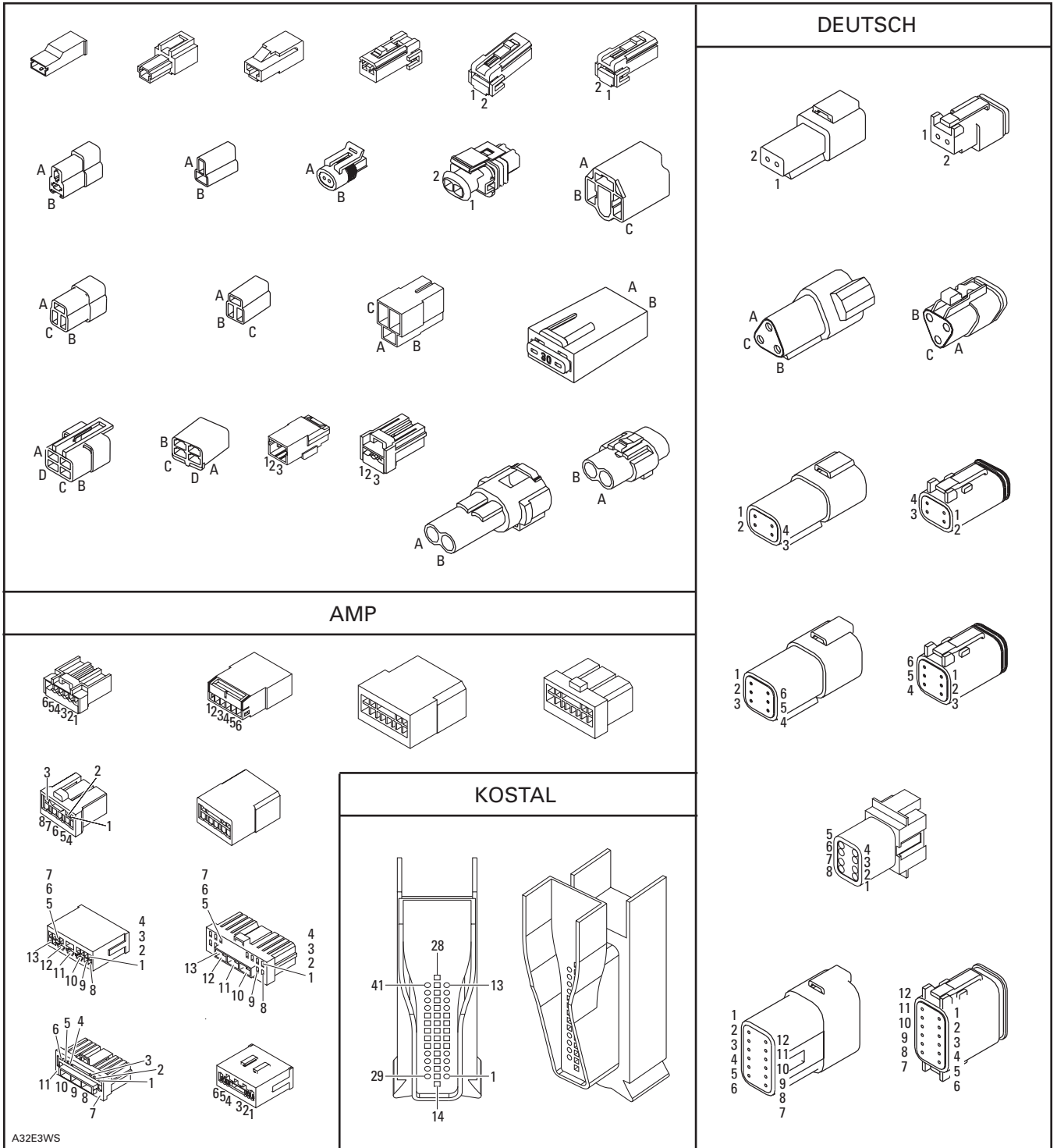







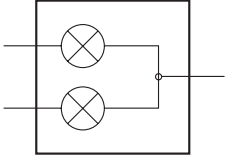
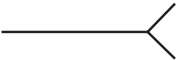
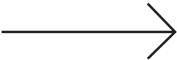
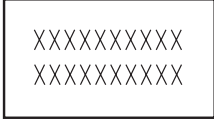
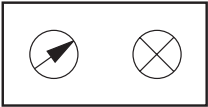
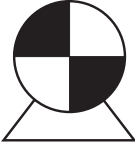
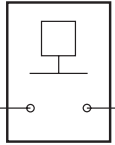
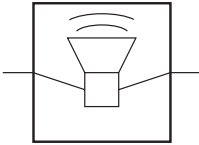

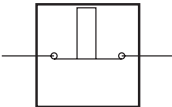
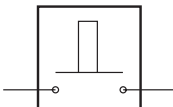

Subsection 01 (WIRING DIAGRAMS)

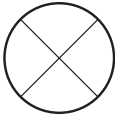
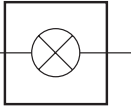
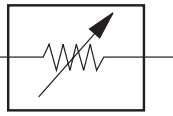
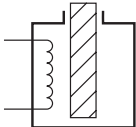

A32E3WS

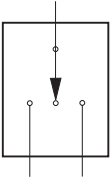
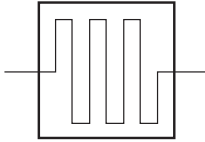
Section 13 WIRING DIAGRAM
 Subsection 01 (WIRING DIAGRAMS)

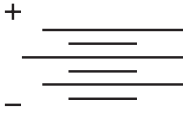
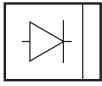
SYMBOLS DESCRIPTION

<p>Beam and tail light</p> 	<p>Female terminal</p> 	<p>Male terminal</p> 	<p>Electronic module</p> 
<p>Meter</p> 	<p>Electric motor</p> 	<p>Low level sensor</p> 	<p>Buzzer</p> 
<p>Ignition coil</p> 	<p>Normally close switch</p> 	<p>Normally open switch</p> 	<p>Male terminal on instrument</p> 
<p>Engine ground</p> 	<p>Frame ground</p> 	<p>Spark plug</p> 	<p>Meter movement</p> 
<p>Bulb</p> 	<p>Pilot</p> 	<p>Analog sensor</p> 	<p>Solenoid valve</p> 
<p>Magneto (Delta)</p> 	<p>3 position switch</p> 	<p>Heating element</p> 	<p>Fuse</p> 
<p>Trigger coil</p> 	<p>Battery</p> 	<p>Diode</p> 	<p>Partially illustrated component</p> 

A00E9PS

UNPLUGGING CONNECTORS

Always unplug connectors by pulling on housing not on wire.

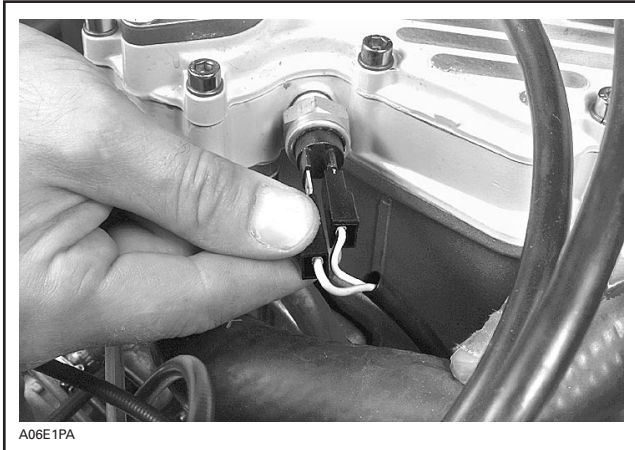

TYPICAL

Throttle Position Sensor (TPS) Connector



TPS CONNECTOR
1. Release button

To disconnect the Sumitomo TPS connector from carburetor, press the release button on the other side of the connector.

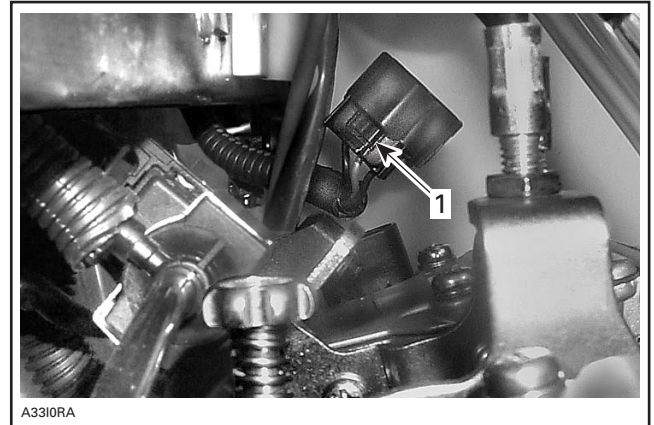

TPS CONNECTOR UNPLUGGED
1. Release button

TAB AND RECEPTACLE CONNECTORS REMOVAL

Tab Connector

It is locked in its housing by a spring tab on its side. Removal is done by squeezing this tab.

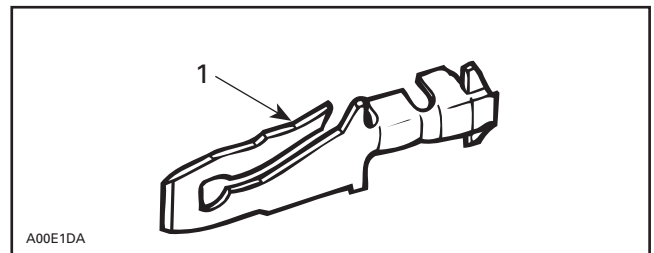

TAB CONNECTOR
1. Locking tab

To remove:

- Insert a screwdriver or Snap-on TT 600-5 from opposite side of wire and pry locking tab.
- While holding locking tab pried, pull connector toward wire side.

Section 13 WIRING DIAGRAM

Subsection 01 (WIRING DIAGRAMS)

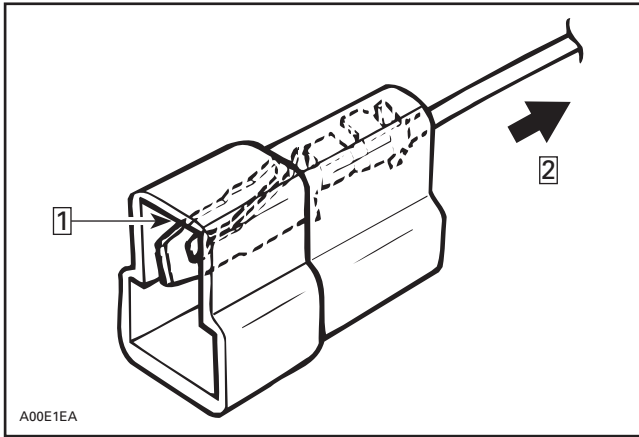

1. Insert screwdriver here
2. Pull this side

Locking Receptacle Connector

To remove:

- Insert tool Snap-on TT 600-5 in access opening then pull housing toward wire side.

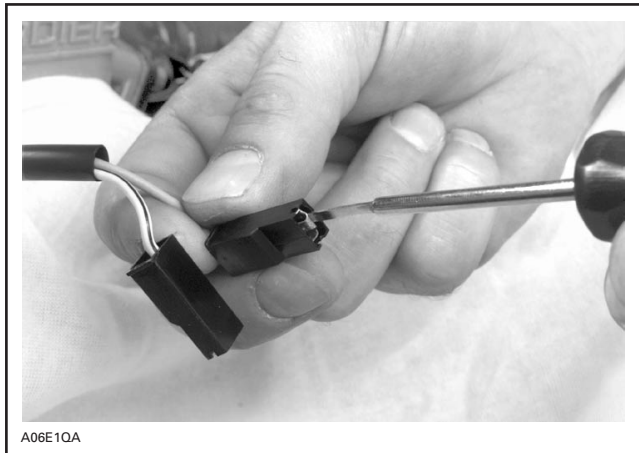

Waterproof Connector Housing

Female Connector Housing

To remove:

- Insert tool Snap-on TT 600-5 under lock and twist to lift it.

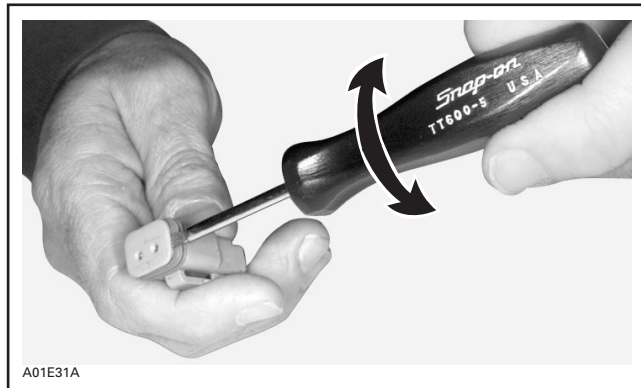

- Pry tab to free connector then pull wire out of housing.

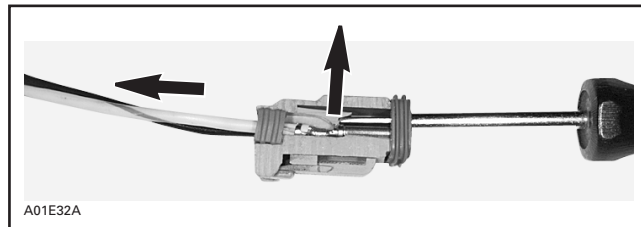

FEMALE CONNECTOR HOUSING — CUT-AWAY

Male Connector Housing

To remove:

- Using a small hook, pull out the lock.

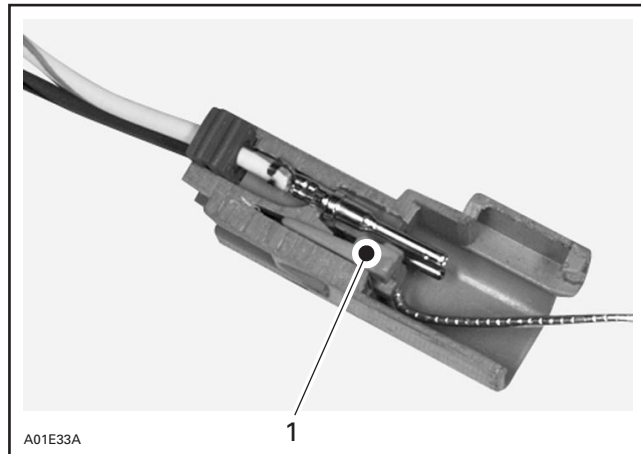

1. Lock

Section 13 WIRING DIAGRAM
Subsection 01 (WIRING DIAGRAMS)

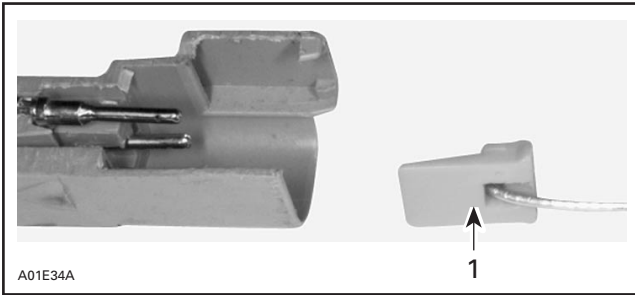

1. Lock

- Pry tab to free connector then pull wire out of housing.

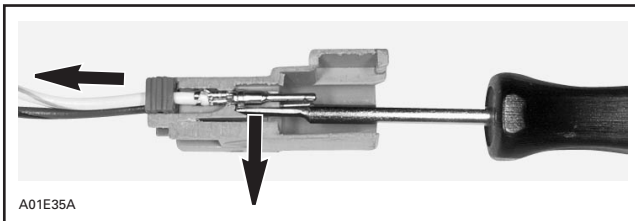

MALE CONNECTOR HOUSING — CUT-AWAY

Multilock Connector Housing
Female Connector Housing

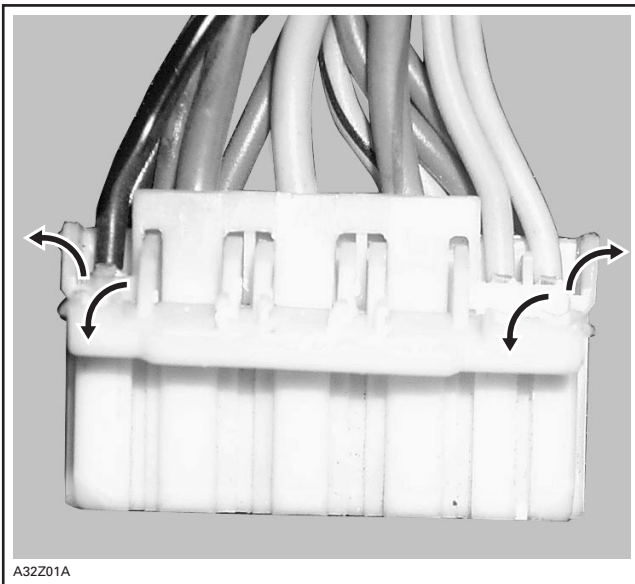

To remove:

- Insert tool AMP- 755430-2 under lock and twist to lift it.

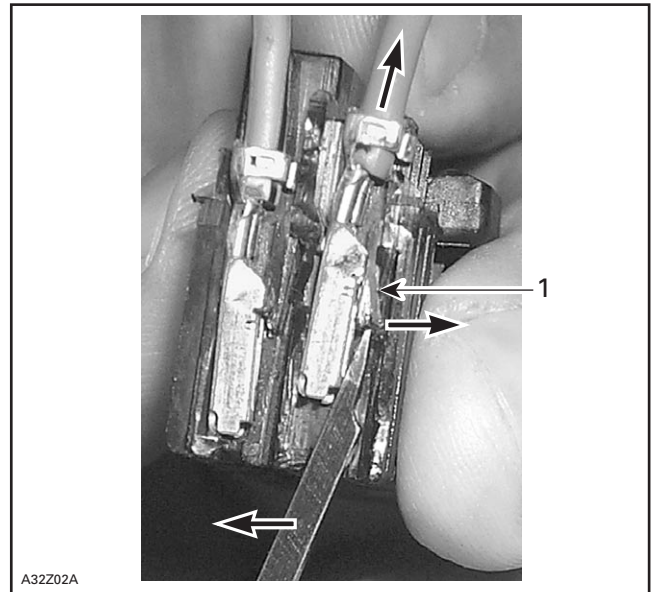

FEMALE CONNECTOR HOUSING — CUT-AWAY
1. Lock

Receptacle connectors can be removed from female housing with sharp head pin.

Male Connector Housing

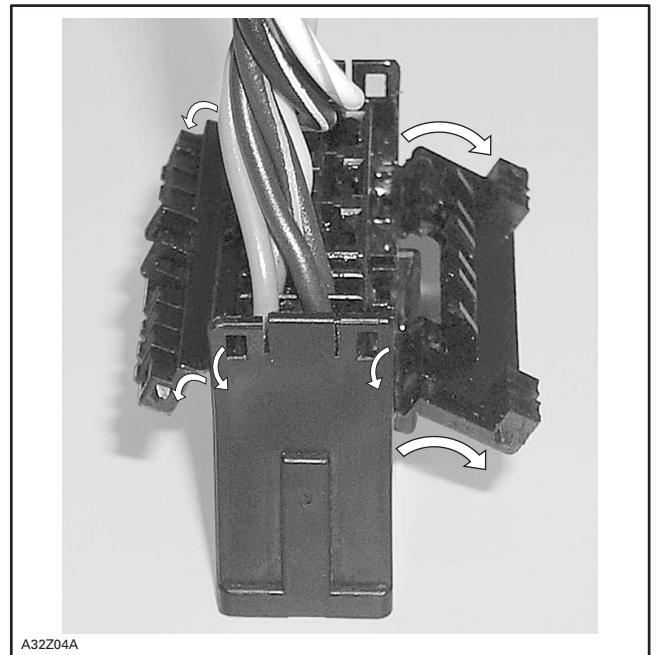

To remove:

- Insert tool AMP-755430-2 under lock and twist to lift it.

Section 13 WIRING DIAGRAM
Subsection 01 (WIRING DIAGRAMS)

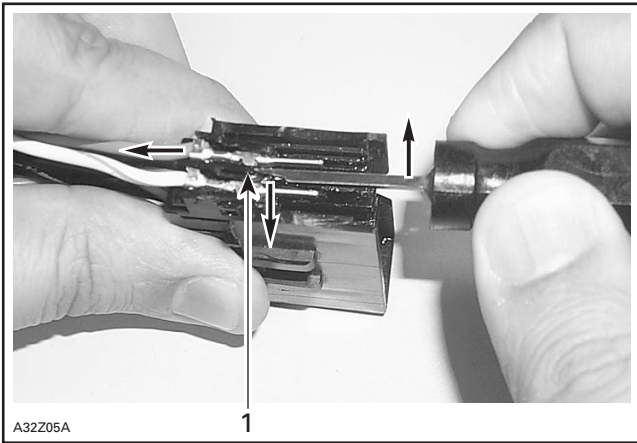

MALE CONNECTOR HOUSING — CUT-AWAY
 1. Lock

24-Circuit Connector Housing

Push on both tabs to remove retainer.

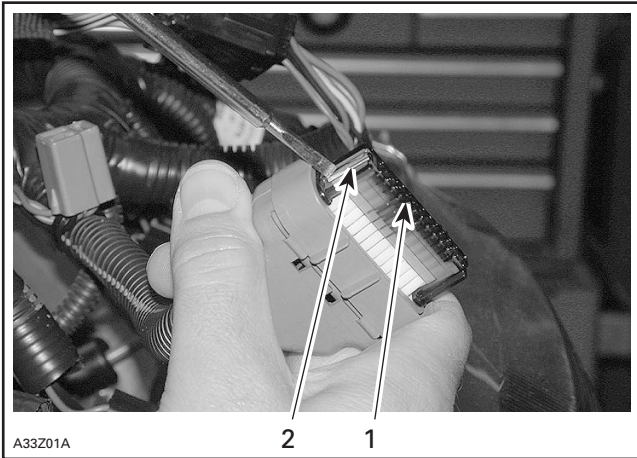

1. Retainer
 2. Tab (one on each side)

Open housing by lifting 4 tabs.

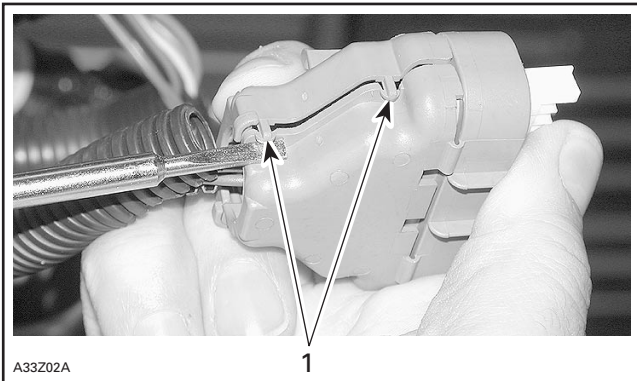

1. Tabs (2 on each side)

Lift the top plastic lock of the female terminal to be removed and hold in position. Lift the female terminal to unlock from the housing and push out of housing.

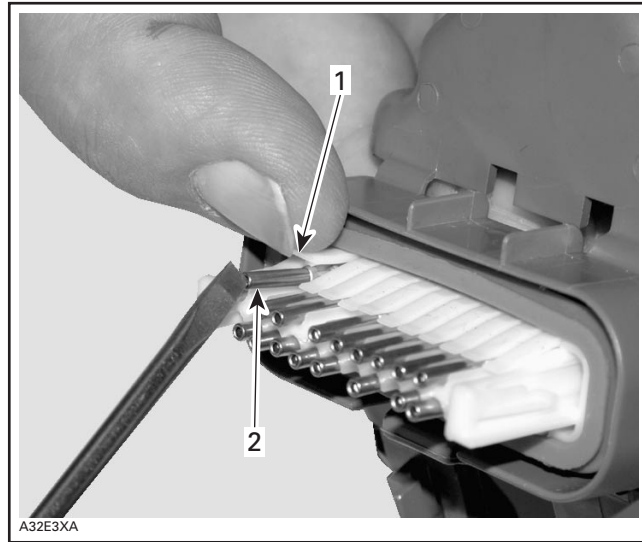

1. Lift and hold plastic lock
 2. Lift to unlock and push out

8-Circuit Connector Housing

Pry housing to release lock.

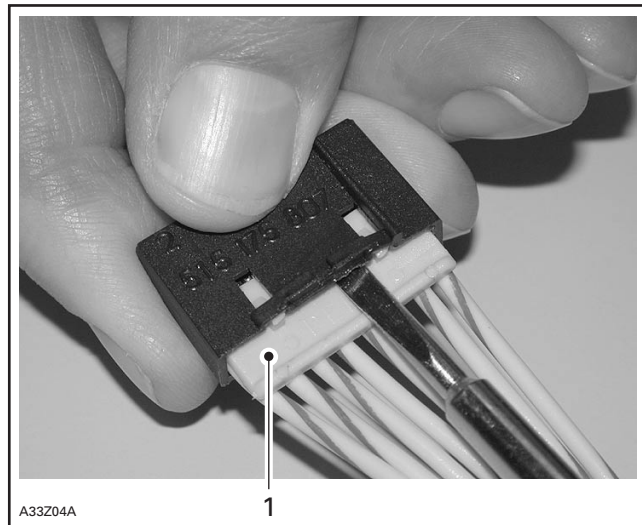

1. Lock

Insert tool AMP-755430-2 under tab and pry it to free connector. Pull on the female terminal wire to remove female terminal from housing.

Section 13 WIRING DIAGRAM

Subsection 01 (WIRING DIAGRAMS)

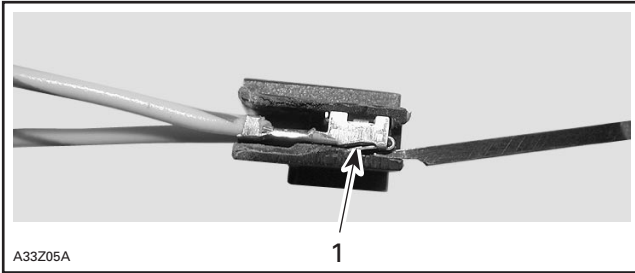

8-CIRCUIT CONNECTOR HOUSING — CUT-AWAY
1. Tab

Connector housing A and B on ECM Terminal Removal

Unlock the connector housing cover by pushing in the tabs on top of the housing with a flat screwdriver to be able to flip the top cover up.

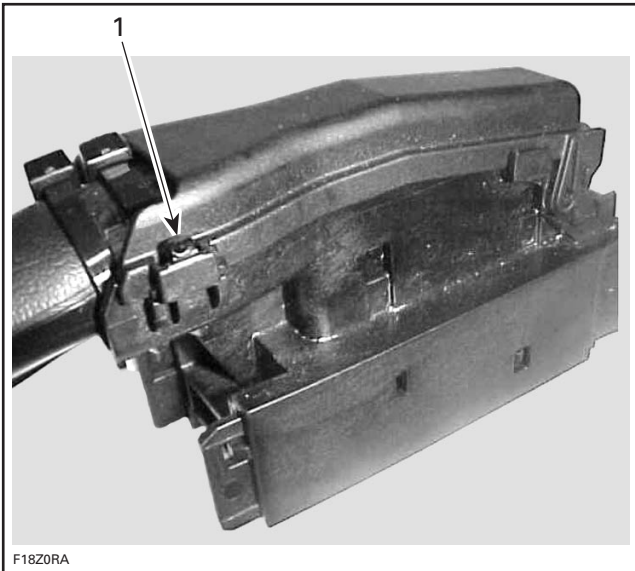

1. Push in tab

Lift the cover by pushing it forward.

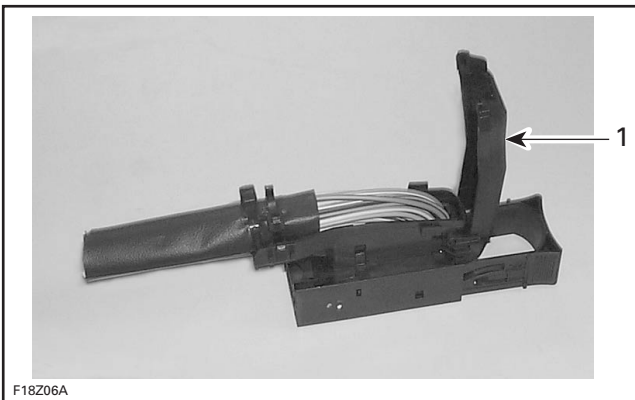

1. Cover

Cut both locking ties that secure the harness to the housing.



1. Locking ties

Turn the housing over and remove the lock by pushing and then pulling toward the wire harness.

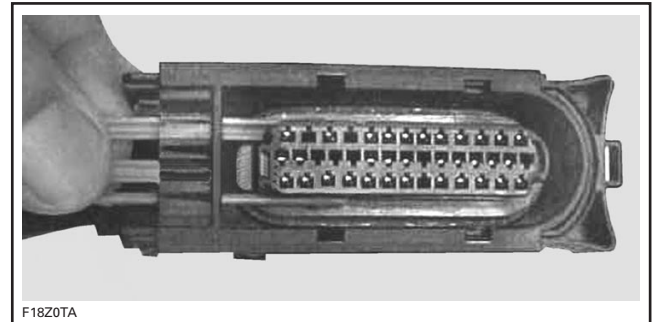
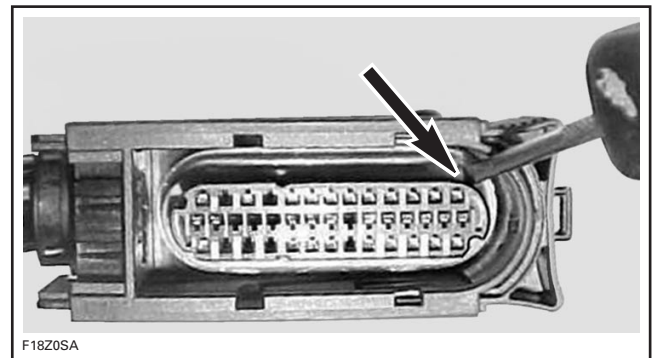

Use a 0.76 mm (.030 in) oxyacetylene torch tip cleaner or a no. 68 drill bit inserted down into the housing to release the locking tab on the connector.

CAUTION: Using a probe larger than 0.76 mm (.030 in) may damage the terminal.

Section 13 WIRING DIAGRAM

Subsection 01 (WIRING DIAGRAMS)

Insert the probe into the housing as shown, and locate the appropriate wire in the back of the housing. You may have to slightly cam the probe against the locking tab to release it, then remove the terminal from the housing.

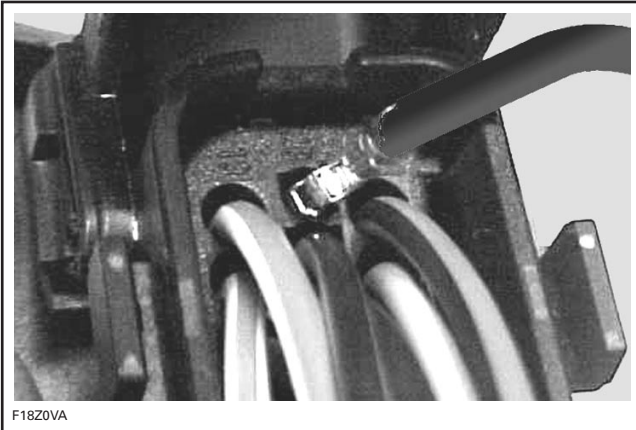
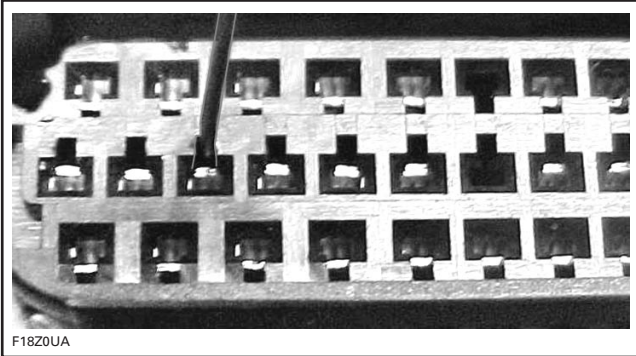

The locking tab on the connector may have to be bent out a little so it will lock in the housing when it's re-inserted.

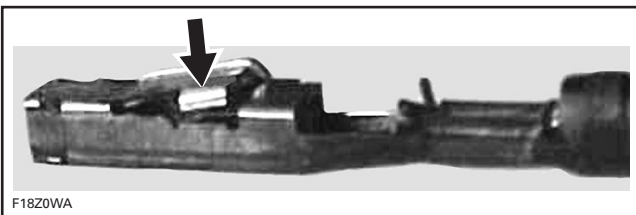

If the wire is in good condition but the terminal is rusted or corroded, remove defective terminal and crimp a new one. If wire and terminal are defective, acquire a new genuine wire and new terminal and crimp them together as explained below.

IMPORTANT: Use genuine wires only. Otherwise wires will not fit properly.

When re-inserting the connector, the locking tab must be installed facing the smaller cutout of the connector cavity.

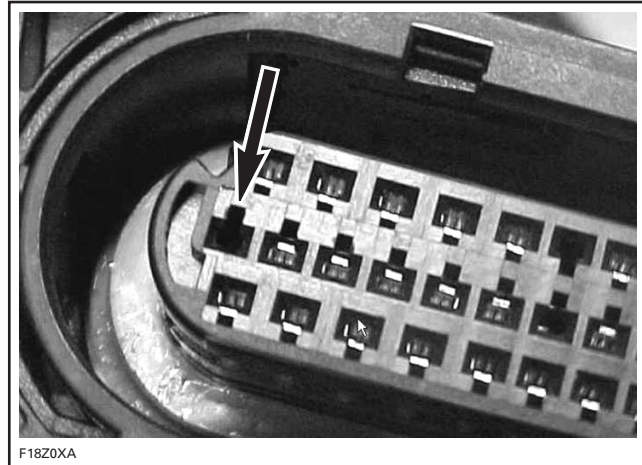

Insert the connector, ensuring the locking tab snaps into the housing.

Re-install the lock, attach the 2 tie raps, and close the housing cover.

Terminal Crimping (Kostal and AMP multilock)

To crimp a new connector terminal, use the connector crimping tool (P/N 529 035 909) and the crimper die (P/N 529 035 906).



CRIMPING TOOL

To properly crimp the wires, strictly follow this procedure.

Strip the wire to a maximum of 3 mm (1/8 in).

Section 13 WIRING DIAGRAM

Subsection 01 (WIRING DIAGRAMS)

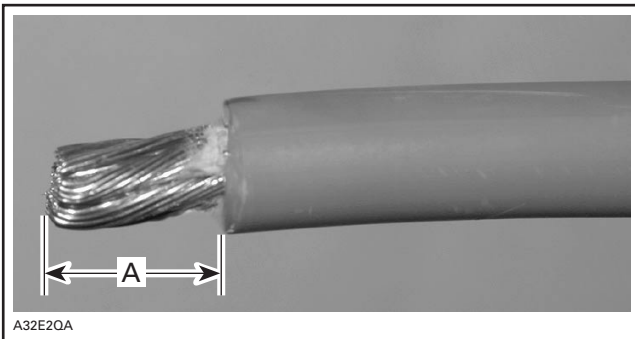

TYPICAL

A. 3 mm (1/8 in) max.

Position wire in terminal.

Squeeze the terminal tabs with your fingers to temporarily retain terminal in place.

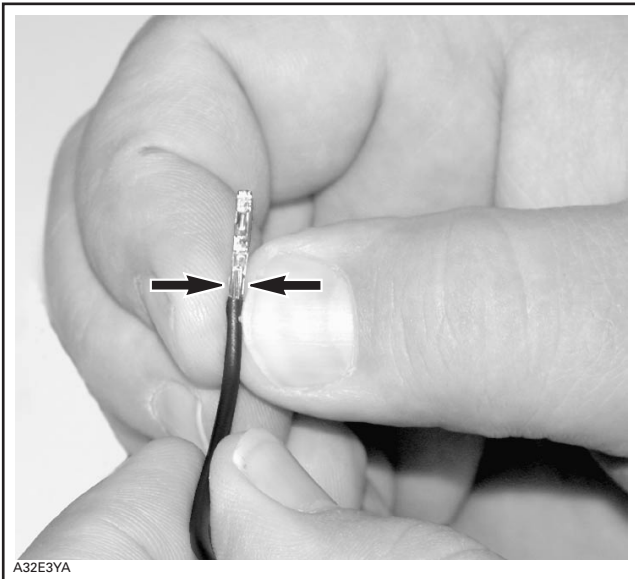

Insert terminal with wire in crimping pliers and position so that top of terminal tabs are flush with pliers edge or a little bit lower as shown.

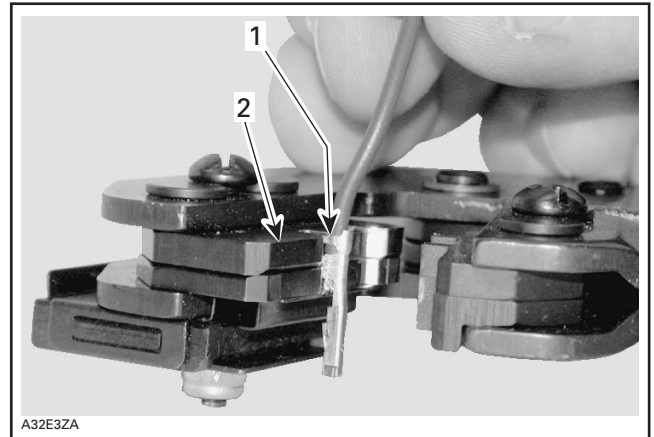

1. Top of terminal tabs
2. Align tabs with pliers edge

Crimp terminal. Ensure no tiny wire goes out of terminal. This might cause strange problems of the electrical system.

TAB AND RECEPTACLE CONNECTORS INSTALLATION

Prior to installing, make sure locking tab is sufficiently lifted to properly lock.

Insert tab and receptacle connectors in their respective housings as shown in following illustrations. Push sufficiently so that they snap. Try pulling wire to ensure they are properly locked.

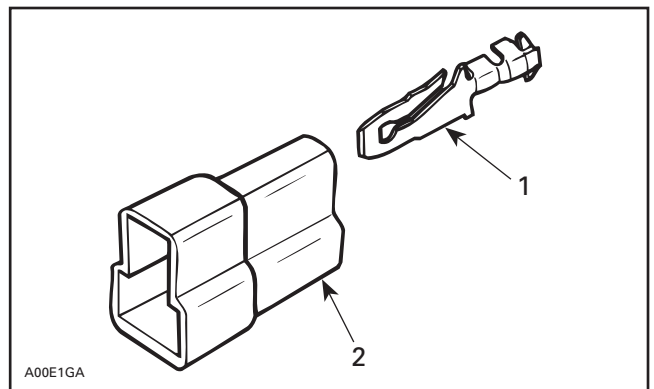

1. Tab
2. Housing

Section 13 WIRING DIAGRAM

Subsection 01 (WIRING DIAGRAMS)

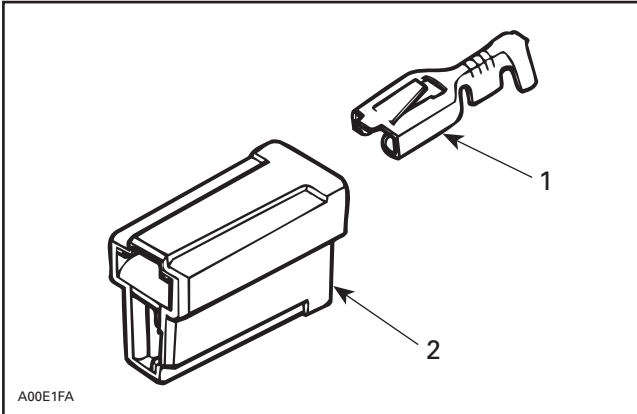

TYPICAL
1. Receptacle
2. Housing

WARNING

Keep wires away from any rotating, moving, heating, vibrating or sharp edge. Use proper fastening devices as required.

Section 13 WIRING DIAGRAM

Subsection 01 (WIRING DIAGRAMS)

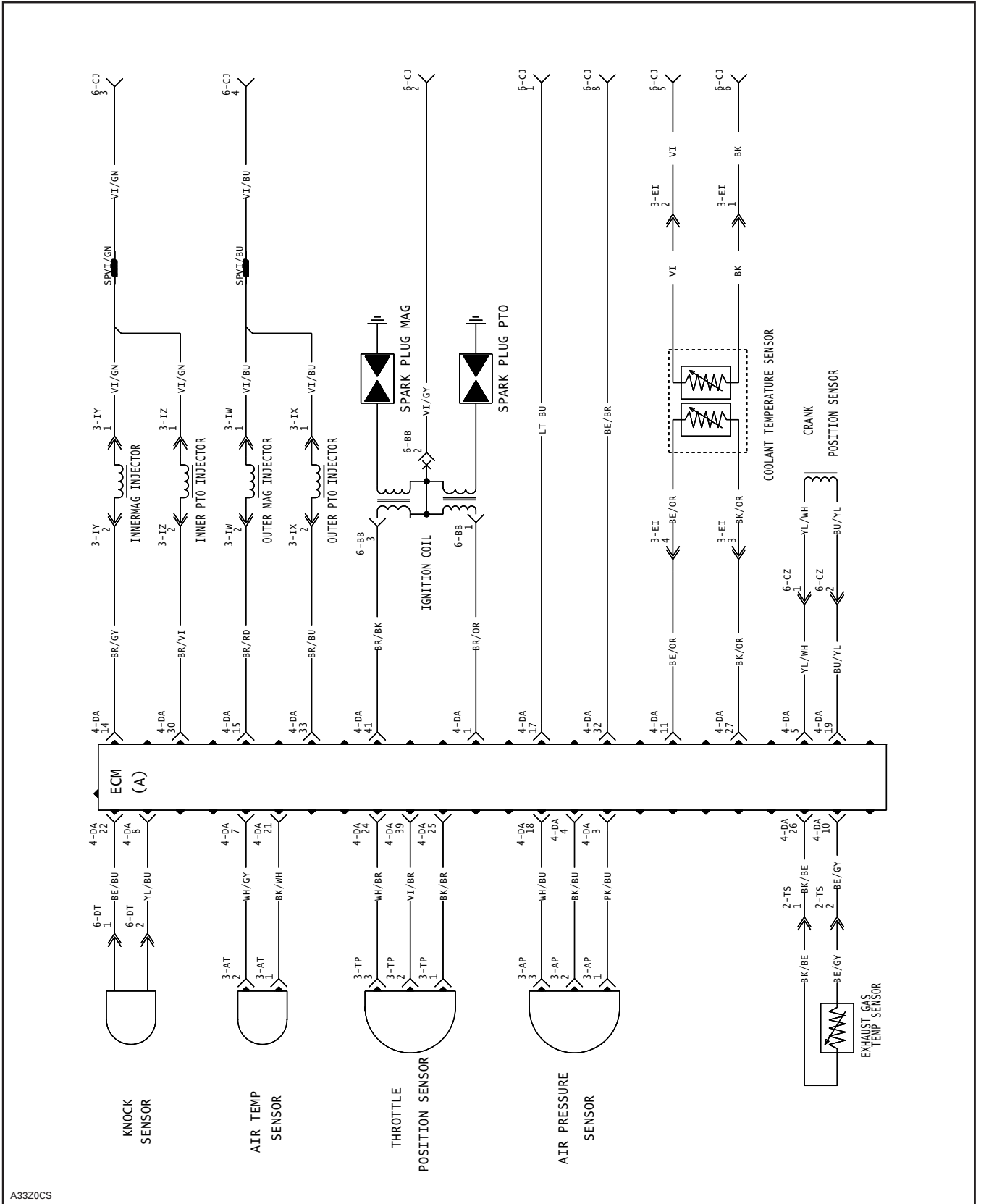

A3320CS

