

ski-doo®

R A C I N G H A N D B O O K

2003



4 8 4 2 0 0 0 4 8

2003 RACING HANDBOOK

TABLE OF CONTENTS

	Section
CONTACTING THE RACE DEPARTMENT	01-1
2003 TECHNICAL INFORMATION	02-1
CHASSIS PREPARATION	03-1
ENGINE PREPARATION	04-1
DRIVE SYSTEM	05-1
2003 800 MOD ENGINE KIT	06-1
2002 MX Zx 440 INFORMATION	07-1
COMPETITION PREPARATION	08-1
SERVICE TOOLS.....	09-1

WARNING

This information relates to the preparation and use of snowmobiles in competitive events. Bombardier Inc. disclaims liability for all damages and/or injuries resulting from the improper use of the contents. We strongly recommend that these modifications be carried out and/or verified by a highly-skilled professional racing mechanic. It is understood that racing or modifications of any Bombardier-made snowmobile voids the vehicle warranty and that such modifications may render use of the vehicle illegal in other than sanctioned racing events under existing federal, provincial and state regulations.

KEEPING YOUR MACHINE LEGAL IS YOUR RESPONSIBILITY

Read the rule book and/or contact organization you will be competing in.

RACE DEPARTMENT CONTACTS

U.S. & CDN RACERS (ENGLISH)

Steve Cowing
Race Marketing Manager

Phone: 651-462-3340

Fax: 651-462-3341

E-mail: steve.cowing@recreation.bombardier.com

- Race Program
- Race Resumes
- Race Sleds Allocation
- Marketing and Communication
- Press Events, Dealer Programs

Tom Lawrence
Race Coordinator
7575 Bombardier Court
Wausau WI. 54401

Phone: 715-848-4971

Fax: 715-847-6879

E-mail: tom.lawrence@recreation.bombardier.com

- Technical Support
- Race Schools
- Race Manual

Parts Order

All Part Numbers with a 486 prefix must be ordered from the Valcourt Race Dept. Please use order form on page 1-4. Order form must be filled out completely to have your order processed. All other part numbers MUST be ordered through your dealer.

Website: www.ski-doo.com/racingzone

- Race Schedule and Results

NOTE: E-mail is the preferred method of communications throughout the year.

SECTION 01 - CONTACTING THE RACE DEPARTMENT

CDN RACERS (FRENCH SPEAKING RACERS ONLY)

Marcel Imbeault
Race Manager

565, de la Montagne
Valcourt, QC J0E 2L0

Phone: 450-532-2211 Ext. 5479

Fax: 450-532-6175

E-mail: marcel.imbeault@recreation.bombardier.com

- Race Program
- Race Resumes
- Race Sleds Allocation

Hélène Despaties
Race Manager Assistant

565, de la Montagne
Valcourt, QC J0E 2L0

Phone: 450-532-2211 Ext. 5075

Fax: 450-532-6175

E-mail: helene.despaties@recreation.bombardier.com

- T.I.P. Sheet Distribution (See T.I.P. Sheet Application on Page 1-3)

Yvon Petit
Race Technician

565, de la Montagne
Valcourt QC. J0E 2L0

Phone: 450-532-2211 Ext. 5803

Fax: 450-532-6175

E-mail: yvon.petit@recreation.bombardier.com

- Technical Support

Parts Order

All Part Numbers with a 486 prefix must be ordered from the Valcourt Race Dept. Please use order form on page 1-4. Order form must be filled out completely to have your order processed. All other part numbers MUST be ordered through your dealer.

Website: www.ski-doo.com/racingzone

- Race Schedule and Results

NOTE: E-mail is the preferred method of communications throughout the year.



T.I.P. SHEET APPLICATION

TECHNICAL INFORMATION POSTING

This form only will be accepted
Last year applications are not valid anymore

Dear Ski-Doo X-Team

Please add my name to your list of recipients for the T.I.P. sheets to be distributed during the 2002-03 race season.

Name: _____ City: _____

To receive the T.I.P. sheets by e-mail, send an e-mail to the following:

helene.despaties@recreation.bombardier.com

and mention to add your address on the tip sheet distribution list

To receive the T.I.P. sheets by fax, send a fax to the following:

Fax to: H el ene Despaties at (450) 532-6175

Fax: _____ (your complete fax number)

and mention to add your name on the tip sheet distribution list

ORDER



Ski-Doo Racing Dept.

BOMBARDIER
RECREATIONAL PRODUCTS

Date:

Page 1 of

ORDER DESK: Robert Bourgeois Racing Parts Coordinator	FAX (450) 532-5076
SHIP TO: <i>(name & complete address needed)</i>	<p><u>If you are a dealer:</u> DEALER #: FED. ID # (US dealer only) →</p> <p><u>If you are a racer:</u> SOCIAL SECURITY # (US racer only) → (we need your SS # for custom regulations)</p>
PHONE #:	FAX #:
PAYMENT: VISA ____ MASTER CARD ____	# _____ Exp. Date: /
SHIPPING CONDITIONS: RED: ____ GROUND: ____ BLUE: ____ <i>(shipping fees will be charged to you)</i>	

DESCRIPTION	PART # OR CLOTHING PART #	QUANTITY	B/O

Please, read the following important notices

- (1) 15% handling fee will be charged on parts return – written approbation needed
- (2) DO NOT CALL BACK for shipping follow-up
- (3) **FAX ORDER ONLY WILL BE ACCEPTED (COMPLETELY FILLED)**

TABLE OF CONTENTS

ENGINE





MX Zx 440 RACING (CAN./U.S.)	02-2
MX Z 600 HO /E/R/X/SPORT/007 SPECIAL EDITION (CAN./U.S.)	02-2
MX Z 800 /E/R/X/ SPORT (CAN./U.S.)	02-2
SUMMIT 700 /R/ HIGHMARK (CAN./U.S.)	02-3
SUMMIT 800 HO /R/ HIGHMARK/X/Xtreme (CAN./U.S.).....	02-3

VEHICLE





MX Zx 440 RACING (CAN./U.S.)	02-4
MX Z 600 HO R/X/ SPORT (CAN./U.S.)	02-4
MX Z 600 HO E/R/ 007 SPECIAL EDITION (CAN./U.S.)	02-4
MX Z 800 E/R/X/ SPORT (CAN./U.S.)	02-5
SUMMIT 700 HIGHMARK (CAN./U.S.).....	02-5
SUMMIT 700 R HIGHMARK (CAN./U.S.)	02-5
SUMMIT 800 HO /R HIGHMARK/X (CAN./U.S.)	02-6
SUMMIT 800 HO R HIGHMARK Xtreme (CAN./U.S.)	02-6

SECTION 02 - 2003 MODELS TECHNICAL DATA

ENGINE





VEHICLE MODEL		MX Zx 440 RACING (CAN./U.S.)	MX Z 600 HO /E/R/X/ SPORT/007 SPECIAL EDITION (CAN./U.S.)	MX Z 800 /E/R/X/ SPORT (CAN./U.S.)		
ENGINE TYPE		453	593	793		
	Number of Cylinders	2	2	2		
	Bore	mm (in)	65.0 (2.56)	72.0 (2.835)	82.0 (32.228)	
	Stroke	mm (in)	65.8 (2.59)	73.0 (2.874)	75.70 (2.980)	
	Displacement	cm ³ (in ³)	436.7 (26.6)	594.40 (36.27)	799.20 (48.77)	
	Compression Ratio	± 0.5	14.8	12.25	12.0	
	Maximum Power Engine Speed ①	± 100 RPM	8400	8000	7850	
	Piston Ring Type	1 st /2 nd	ST/N.A.	ST/N.A.	ST/N.A.	
	Ring End Gap	New	mm (in)	0.4 (.0157)	0.4 (.016)	0.4 (.016)
		Wear Limit	mm (in)	1.0 (.040)	1.0 (.039)	1.0 (.039)
	Ring/Piston Groove Clearance	New	mm (in)	0.04 (.0016)	0.045 (.0018)	0.05 (.0020)
		Wear Limit	mm (in)	0.2 (.0079)	0.2 (.0079)	0.2 (.0079)
	Piston/Cylinder Wall Clearance	New	mm (in)	0.10 ± 0.016 (.0039 ± 0.0006)	0.105 ± 0.023 (.0041 ± .0009)	0.125 ± 0.023 (.0049 ± .0009)
		Wear Limit	mm (in)	0.20 (.0079)	0.20 (.0079)	0.20 (.0079)
	Connecting Rod Big End Axial Play	New	mm (in)	0.39 (.0154)	0.39 (.0154)	0.39 (.0154)
Wear Limit		mm (in)	1.2 (.0472)	1.2 (.0472)	1.2 (.0472)	
Maximum Crankshaft End-play ②	mm (in)	0.3 (.0118)	0.3 (.012)	0.3 (.012)		
Maximum Crankshaft Deflection at PTO	mm (in)	0.06 (.0024)	0.06 (.0024)	0.06 (.0024)		
	Magneto Generator Output	W	290	360	360	
	Ignition Type		CDI	CDI	CDI	
	Spark Plug Make and Type		NGK BR9ECS	NGK BR9ECS	NGK BR9ECS	
	Spark Plug Gap	± 0.05 mm (± .002 in)	0.45 (.018)	0.45 (.018)	0.45 (.018)	
	Ignition Timing BTDC ③	mm (in)	3.14 (.124)	2.79 (.110)	2.92 (.115)	
	Trigger Coil ④	Ω	190 – 300	190 – 300	190 – 300	
	Generating Coil ④	Low Speed	Ω	17.5 – 42.5	N.A.	N.A.
		High Speed	Ω	2.4 - 5.8	N.A.	N.A.
	Lighting Coil ④	Ω	0.1 – 0.4	0.1 – 1.0	0.1 – 1.0	
	High Tension Coil ④	Primary	Ω	0.3 – 0.7	N.A.	N.A.
Secondary		kΩ	N.A.	N.A.	N.A.	
	Carburetor Type	PTO/MAG	TMX 34-23	TM 40-B238	TM 40-B250	
	Main Jet	PTO/MAG	390	380/380	380/380	
	Needle Jet		Q-6	P-0 ⑤	P-0 ⑤	
	Pilot Jet		25	17.5	17.5	
	Needle Identification — Clip Position	PTO/MAG	6FIY4 – 4	9DHI13-58 ⑥	9DG17-58 ⑥	
	Slide Cut-Away		4.0	1.5	2.0	
	Float Adjustment	± 1 mm (± .040 in)	N.A.	N.A.	N.A.	
	Air or Pilot Screw Adjustment	± 1/16 turn	1.0	1-1/2	1.5	
	Idle Speed	± 200 RPM	1800	1600	1500	
	Gas Type/Pump Octane Number		Unleaded/87	Unleaded/87	Unleaded/87	
Gas/Oil Ratio		Injection	Injection	Injection		
	Type		Liquid	Liquid	Liquid	
	Axial Fan Belt Adjustment	Deflection	mm (in)	N.A.	N.A.	N.A.
		Force	kg (lbf)	N.A.	N.A.	N.A.
	Thermostat Opening Temperature	°C (°F)	42 (108)	42 (108)	42 (108)	
Radiator Cap Opening Pressure	kPa (PSI)	90 (13)	90 (13)	90 (13)		
	ENGINE COLD N·m (lb·ft)	Drive Pulley Retaining Screw		⑦	⑦	⑦
		Exhaust Manifold Nuts or Bolts		21.5 (16)	22 (16)	22 (16)
		Magneto Ring Nut		125 (92)	125 (92)	125 (92)
		Crankcase Nuts or Screws	M6	9 (6.5)	9 (7)	9 (7)
			M8	29 (21)	29 (21)	29 (21)
		Crankcase/Engine Support Nuts or Screws		35 (26)	35 (26)	9 (7) 29 (21)
		Cylinder Head Screws		29 (21)	29 (21)	29 (21)
		Crankcase/Cylinder Nuts or Screws		29 (21)	29 (21)	40 (29)
Axial Fan Shaft Nut		N.A.	N.A.	N.A.		

SECTION 02 - 2003 MODELS TECHNICAL DATA



VEHICLE MODEL		SUMMIT 700 /R/ HIGHMARK (CAN./U.S.)	SUMMIT 800 HO /R/ HIGHMARK/X/Xtreme (CAN./U.S.)		
ENGINE TYPE		693	793		
	Number of Cylinders	2	2		
	Bore	mm (in)	78.0 (3.071)	82.0 (3.228)	
	Stroke	mm (in)	73.0 (2.874)	75.70 (2.980)	
	Displacement	cm ³ (in ³)	697.70 (42.58)	799.20 (48.77)	
	Compression Ratio	± 0.5	12.0	13.3	
	Maximum Power Engine Speed ①	± 100 RPM	8000	7850	
	Piston Ring Type	1 st /2 nd	ST/N.A.	ST/N.A.	
	Ring End Gap	New	mm (in)	0.4 (.016)	0.4 (.016)
		Wear Limit	mm (in)	1.0 (.039)	1.0 (.039)
	Ring/Piston Groove Clearance	New	mm (in)	0.04 (.0016)	0.05 (.0020)
		Wear Limit	mm (in)	0.2 (.0079)	0.2 (.0079)
	Piston/Cylinder Wall Clearance	New	mm (in)	0.115 ± 0.013 (.0045 ± .0005)	0.125 ± 0.023 (.0049 ± .0009)
		Wear Limit	mm (in)	0.20 (.0079)	0.20 (.0079)
	Connecting Rod Big End Axial Play	New	mm (in)	0.39 (.0154)	0.39 (.0154)
Wear Limit		mm (in)	1.2 (.0472)	1.2 (.0472)	
Maximum Crankshaft End-play ②	mm (in)	0.3 (.012)	0.3 (.012)		
Maximum Crankshaft Deflection at PTO	mm (in)	0.06 (.0024)	0.06 (.0024)		
	Magneto Generator Output	W	360	360	
	Ignition Type		CDI	CDI	
	Spark Plug Make and Type		NGK BR9ECS	NGK BR9ECS	
	Spark Plug Gap	± 0.05 mm (± .002 in)	N.A.®	N.A.®	
	Ignition Timing BTDC ③	mm (in)	3.37 (.133)	2.37 (.093)	
	Trigger Coil ④	Ω	190 – 300	190 – 300	
	Generating Coil ④	Low Speed	Ω	N.A.	N.A.
		High Speed	Ω	N.A.	N.A.
	Lighting Coil ④	Ω	0.1 – 1.0	0.1 – 1.0	
	High Tension Coil ④	Primary	Ω	N.A.	N.A.
Secondary		kΩ	N.A.	N.A.	
	Carburetor Type	PTO/MAG	TM 40-B259	TM 40-B247	
	Main Jet	PTO/MAG	500/500	430/430	
	Needle Jet		P-0 ⑤	P-0 ⑤	
	Pilot Jet		17.5	17.5	
	Needle Identification — Clip Position	PTO/MAG	9ZLY7-58-3 ⑥	9DHI12-58-3 ⑥	
	Slide Cut-Away		2.0	2.0	
	Float Adjustment	± 1 mm (± .040 in)	N.A.	N.A.	
	Air or Pilot Screw Adjustment	± 1/16 turn	1-1/2	1-1/2	
	Idle Speed	± 200 RPM	1500	1500	
	Gas Type/Pump Octane Number		Unleaded/87	Unleaded/87	
	Gas/Oil Ratio		Injection	Injection	
	Type		Liquid	Liquid	
	Axial Fan Belt Adjustment	Deflection	mm (in)	N.A.	N.A.
		Force	kg (lbf)	N.A.	N.A.
	Thermostat Opening Temperature	°C (°F)	42 (108)	42 (108)	
Radiator Cap Opening Pressure	kPa (PSI)	90 (13)	90 (13)		
	ENGINE COLD N·m (lb·ft)	Drive Pulley Retaining Screw		⑦	⑦
		Exhaust Manifold Nuts or Bolts		22 (16)	22 (16)
		Magneto Ring Nut		125 (92)	125 (92)
		Crankcase Nuts or Screws	M6	9 (7)	9 (7)
			M8	29 (21)	29 (21)
		Crankcase/Engine Support Nuts or Screws		35 (26)	35 (26)
		Cylinder Head Screws		29 (21)	29 (21)
		Crankcase/Cylinder Nuts or Screws		40 (29)	40 (29)
Axial Fan Shaft Nut		N.A.	N.A.		

SECTION 02 - 2003 MODELS TECHNICAL DATA

VEHICLE

VEHICLE MODEL		MX Zx 440 RACING (CAN./U.S.)	MX Z 600 HO R/X/ SPORT (CAN./U.S.)	MX Z 600 HO E/R/ 007 SPECIAL EDITION (CAN./U.S.)		
ENGINE TYPE		453	593	593		
	Chain Drive Ratio	21/43	24/43	24/43		
	Chain	Pitch	9.525 (.375) mm (in)	9.525 (.375)	9.525 (.375)	
		Type/Links Qty/Plates Qty	Silent 74 - 15	Silent 72/13	Silent 72/13	
	Drive Pulley	Type of Drive Pulley	TRA	TRA III	TRA III	
		Ramp Identification and Roller Pin Type	296 ⑤	410 ④	410 ④	
		Calibration Screw Position or Calibration Part	5	3	3	
		Spring Color	Blue	Violet/Violet	Violet/Violet	
		Spring Length	120 (4.72) mm (in)	107 (4.212)	107 (4.212)	
		Clutch Engagement	± 100 RPM	5000	3800	
	Driven Pulley	Type	FORMULA	HPV27 VSA	HPV27 VSA	
		Spring Preload	± 0.7 kg (± 1.5 lb)	N.A.	N.A.	
		Cam Angle	Degree	53°/47°	47/44	
	Pulley Distance	Z	± 0.5 mm (± .020 in)	17.5 (.689)	20 (.787)	
	Offset	X	± 0.5 mm (± .020 in)	35.5 (1-25/64)	37 (1.457)	
		Y - X	MIN. - MAX.	1.5 (0.059) mm (in)	1.5 ± 0.75 (.059 ± .030)	
	Drive Belt Part Number (P/N)		414 860 700	417 300 197	417 300 197	
	Drive Belt Width (wear limit)		32.5 (1-280) mm (in)	33.4 (1.31)	33.4 (1.31)	
	Drive Belt Adjustment	Deflection	± 5 mm (± .197 in)	32 (1.260)	32 (1.260)	
		Force ②	kg (lbf)	11.3 (25)	11.3 (25)	
	Track	Width	381 (15.0) mm (in)	381 (15.0)	381 (15.0)	
		Length	3074 (121) mm (in)	3074 (121)	3074 (121)	
		Profile Height	41.3 (1.625) mm (in)	STD: 25.4 (1.000) OPT: 31.8 (1.25)	STD: 25.4 (1.000) OPT: 31.8 (1.25)	
		Adjustment	Deflection	30 - 35 (1-11/64 - 1-3/8) mm (in)	30 - 35 (1-3/16 - 1-3/8)	30 - 35 (1-3/16 - 1-3/8)
			Force ③	7.3 (16) kg (lbf)	7.3 (16)	7.3 (16)
	Suspension Type	Track	SC10 III	SC-10 III	SC-10 III	
		Ski	R.A.S. A-Arm	R.A.S. A-Arm	R.A.S. A-Arm	
		Length	278.7(109.7) mm (in)	2787 (109.7)	2787 (109.7)	
		Width	121.7 (47.9) mm (in)	1217 (47.9)	1217 (47.9)	
Height		1280 (50.4) mm (in)	1280 (50.4)	1280 (50.4)		
Ski Stance (carbide to carbide)		1080 (42.5) mm (in)	1195 (47.0)	1195 (47.0)		
Mass (dry)		199 (438) kg (lb)	208 (457)	220 (483)		
Ground Contact Area		6670 (1034) cm² (in²)	6836 (1060)	6836 (1060)		
Ground Contact Pressure		2.93 (.425) kPa (PSI)	2.98 (.432)	3.16 (.458)		
Frame Material		Aluminum	Aluminum	Aluminum		
Bottom Pan Material		Impact copolymer	Impact copolymer	Impact copolymer		
Hood Material		Surlyn	Surlyn	Surlyn		
	Battery	V/A•h	N.A.	N.A.		
	Headlight	W	H4 60/55	H4 60/55		
	Taillight and Stoplight	W	8/27	8/27		
	Tachometer and Speedometer Bulbs	W	2 x 3	2 x 3		
	Fuel and Temperature Gauge Bulbs	W	N.A.	N.A.		
	Fuse	Starter Solenoid	A	N.A.	30	
		Fuel Level Sensor	A	N.A.	.25	
	Fuel Tank	L (U.S. gal)	21 (5.5)	41 (10.8)		
	Chaincase/Gearbox	mL (U.S. oz)	250 (8.5)	250 (8.5)		
	Cooling System ①	L (U.S. oz)	4.3 (145.4)	4.3 (145.4)		
	Injection Oil Reservoir	L (U.S. oz)	N.A.	3.5 (118.4)		

SECTION 02 - 2003 MODELS TECHNICAL DATA

VEHICLE MODEL		MX Z 800 E/R/X/ SPORT (CAN./U.S.)	SUMMIT 700 HIGHMARK (CAN./U.S.)	SUMMIT 700 R HIGHMARK (CAN./U.S.)	
ENGINE TYPE		593	693	693	
Chain Drive Ratio		26/43	19/43	19/43	
Chain	Pitch	mm (in) 9.525 (.375)	9.525 (.375)	9.525 (.375)	
	Type/Links Qty/Plates Qty	Silent 72/13	Silent 72/13	Silent 72/13	
Drive Pulley	Type of Drive Pulley	TRA III	TRA	TRA	
	Ramp Identification and Roller Pin Type	414 ④	299 ⑦	300 ⑦	
	Calibration Screw Position or Calibration Part	3	1	1	
	Spring Color	Violet/Yellow	Violet/Yellow	Violet/Yellow	
	Spring Length	mm (in) 157.9 (6.217)	157.9 (6.22)	157.9 (6.22)	
	Clutch Engagement	± 100 RPM 3800	4100	4100	
Driven Pulley	Type	HPV27 VSA	FORMULA	HPV27	
	Spring Preload	± 0.7 kg (± 1.5 lb) N.A.	8 (18)	N.A.	
	Cam Angle	Degree 47/44	47	44	
Pulley Distance	Z	± 0.5 mm (± .020 in) 20 (.787)	16.5 (.650)	17.5 (.689)	
	X	± 0.5 mm (± .020 in) 37 (1.457)	35.5 (1.398)	35.5 (1.398)	
Offset	Y - X	MIN. - MAX. mm (in) 1.5 ± 0.75 (.059 ± .030)	1.5 ± 0.75 (.059 ± .030)	1.5 ± 0.75 (.059 ± .030)	
	Drive Belt Part Number (P/N)		417 300 166	417 300 127	417 300 127
Drive Belt Width (wear limit)		mm (in) 34.7 (1.366)	33.4 (1.31)	33.4 (1.31)	
Drive Belt Adjustment	Deflection	± 5 mm (± .197 in) 32 (1.260)	32 (1.260)	32 (1.260)	
	Force ②	kg (lbf) 11.3 (25)	11.3 (25)	11.3 (25)	
Track	Width	mm (in) 381 (15.0)	381 (15.0)	381 (15.0)	
	Length	mm (in) 3074 (121)	3836 (151)	3836 (151)	
	Profile Height	mm (in) STD: 25.4 (1.000) OPT: 31.8 (1.25)	50.8 (2.0)	50.8 (2.0)	
	Adjustment	Deflection	mm (in) 30 - 35 (1-3/16 - 1-3/8)	30 - 35 (1-3/16 - 1-3/8)	30 - 35 (1-3/16 - 1-3/8)
		Force ③	kg (lbf) 7.3 (16)	7.3 (16)	7.3 (16)
Suspension Type	Track	SC-10 III	SC-10 151	SC-10 151	
	Ski	R.A.S. A-Arm	ADSA	ADSA	
	Length	mm (in) 2787 (109.7)	3216 (126.6)	3216 (126.6)	
	Width	mm (in) 1217 (47.9)	1139 (44.8)	1139 (44.8)	
	Height	mm (in) 1280 (50.4)	1130 (44)	1130 (44)	
	Ski Stance (carbide to carbide)	mm (in) 1195 (47.0)	1025 (40.4)	1025 (40.4)	
	Mass (dry)	kg (lb) 208 (457)	238 (523)	238 (523)	
	Ground Contact Area	cm ² (in ²) 6836 (1060)	9141 (1417)	9141 (1417)	
	Ground Contact Pressure	kPa (PSI) 2.98 (.432)	2.55 (.370)	2.55 (.370)	
	Frame Material	Aluminum	Aluminum	Aluminum	
	Bottom Pan Material	Impact copolymer	Impact copolymer	Impact copolymer	
	Hood Material	Surlyn	RRIM Polyurethane	RRIM Polyurethane	
	Battery	V/A•h N.A.	N.A.	N.A.	
	Headlight	W H4 60/55	H4 60/55	H4 60/55	
	Taillight and Stoplight	W 8/27	8/27	8/27	
	Tachometer and Speedometer Bulbs	W 2 x 3	2 x 3	2 x 3	
	Fuel and Temperature Gauge Bulbs	W N.A.	N.A.	N.A.	
	Fuse	Starter Solenoid	A N.A.	N.A.	N.A.
		Fuel Level Sensor	A N.A.	N.A.	N.A.
	Fuel Tank	L (U.S. gal) 41 (10.8)	37.3 (9.9)	37.3 (9.9)	
	Chaincase/Gearbox	mL (U.S. oz) 250 (8.5)	250 (8.5)	250 (8.5)	
	Cooling System ①	L (U.S. oz) 4.3 (145.4)	4 (135.3)	4 (135.3)	
	Injection Oil Reservoir	L (U.S. oz) 3.5 (118.4)	3.5 (118.4)	3.5 (118.4)	

SECTION 02 - 2003 MODELS TECHNICAL DATA

VEHICLE MODEL		SUMMIT 800 HO /R HIGHMARK/X (CAN./U.S.)	SUMMIT 800 HO R HIGHMARK Xtreme (CAN./U.S.)	
ENGINE TYPE		793	793	
Chain Drive Ratio		21/43	19/43	
Chain	Pitch	mm (in) 9.525 (.375)	9.525 (.375)	
	Type/Links Qty/Plates Qty	Silent 74/13	Silent 72/13	
Drive Pulley	Type of Drive Pulley	TRA III	TRA III	
	Ramp Identification and Roller Pin Type	415 ⑦	415 ⑦	
	Calibration Screw Position or Calibration Part	1	1	
	Spring Color	Violet/Yellow	Violet/Yellow	
	Spring Length	mm (in) 157.9 (6.217)	157.9 (6.217)	
	Clutch Engagement	± 100 RPM 3800	3800	
Driven Pulley	Type	HPV27	HPV27	
	Spring Preload	± 0.7 kg (± 1.5 lb) N.A.	N.A.	
	Cam Angle	Degree 44	44	
Pulley Distance	Z	± 0.5 mm (± .020 in) 20 (.787)	20 (.787)	
	X	± 0.5 mm (± .020 in) 37 (1.457)	37 (1.457)	
Offset	Y - X	MIN. - MAX. mm (in) 1.5 ± 0.75 (.059 ± .030)	1.5 ± 0.75 (.059 ± .030)	
Drive Belt Part Number (P/N)		417 300 166	417 300 166	
Drive Belt Width (wear limit)		mm (in) 34.7 (1.366)	34.7 (1.366)	
Drive Belt Adjustment	Deflection	± 5 mm (± .197 in) 32 (1.260)	32 (1.260)	
	Force ②	kg (lbf) 11.3 (25)	11.3 (25)	
Track	Width	mm (in) 381 (15.0)	381 (15.0)	
	Length	mm (in) 3836 (151)	4039 (159)	
	Profile Height	mm (in) 50.8 (2.0)	50.8 (2.0)	
	Adjustment	Deflection	mm (in) 30 - 35 (1-3/16 - 1-3/8)	30 - 35 (1-3/16 - 1-3/8)
		Force ③	kg (lbf) 7.3 (16)	7.3 (16)
Suspension Type	Track	SC-10 151	SC-10 159	
	Ski	ADSA	ADSA	
Length		mm (in) 3216 (127)	3314 (130)	
Width		mm (in) 1139 (44.8)	1139 (44.8)	
Height		mm (in) 1130 (44)	1130 (44)	
Ski Stance (carbide to carbide)		mm (in) 1025 (40.3)	1025 (40.3)	
Mass (dry)		kg (lb) 240 (529)	243 (534)	
Ground Contact Area		cm ² (in ²) 9641 (1417)	9599 (1488)	
Ground Contact Pressure		kPa (PSI) 2.58 (.374)	2.48 (.360)	
Frame Material		Aluminum	Aluminum	
Bottom Pan Material		Impact copolymer	Impact copolymer	
Hood Material		RRIM Polyurethane	RRIM Polyurethane	
Battery		V/A•h N.A.	N.A.	
Headlight		W H4 60/55	H4 60/55	
Taillight and Stoplight		W 8/27	8/27	
Tachometer and Speedometer Bulbs		W 2 x 3	2 x 3	
Fuel and Temperature Gauge Bulbs		W N.A.	N.A.	
Fuse	Starter Solenoid	A N.A.	N.A.	
	Fuel Level Sensor	A N.A.	N.A.	
Fuel Tank		L (U.S. gal) 37.3 (9.9)	37.3 (9.9)	
Chaincase/Gearbox		mL (U.S. oz) 250 (8.5)	250 (8.5)	
Cooling System ①		L (U.S. oz) 4.3 (143.7)	4.3 (143.7)	
Injection Oil Reservoir		L (U.S. oz) 3.5 (118.4)	3.5 (118.4)	

TABLE OF CONTENTS

SUSPENSION OPERATION/WEIGHT TRANSFER	03-2
SPRINGS	03-3
SPRING DESCRIPTION	03-8
COIL SPRINGS (COMPRESSION).....	03-8
TORSION SPRINGS.....	03-9
SPRING APPLICATIONS	03-10
SPRING SPECIFICATIONS	03-13
CORNERING DYNAMICS	03-16
SHOCKS	03-17
INTERNAL FLOATING PISTON MEASUREMENT	03-28
2003 MX ZX 440 HPG C-36 SHOCKS	03-29
SHOCK REBUILD PROCEDURE	03-30
SHOCK VALVING	03-33
SHOCK CALIBRATION WORK SHEET	03-35
CHASSIS SET-UP.....	03-36
BRAKES.....	03-39
AERODYNAMIC CONSIDERATIONS.....	03-39
ADJUSTING RIDE HEIGHT	03-40
TRACK GUIDES	03-41
TRACK STUDDING.....	03-41
SKIS AND RUNNERS	03-42
BUMP STEER	03-43
SKI LEG CAMBER.....	03-44
SKI TOE-OUT	03-44
CHASSIS TUNING GUIDELINES	03-45

SECTION 03 - CHASSIS PREPARATION

SUSPENSION OPERATION/WEIGHT TRANSFER

The purpose of any suspension system is to isolate the rider from the terrain while still allowing for complete control of the vehicle. A snowmobile rear suspension has the added requirements of providing weight transfer and maintaining correct track tension.

Weight transfer is essentially the shifting of weight to the track for better traction during acceleration, and to the skis for positive handling during cornering.

The physics that apply to all rear suspensions are basically the same. As we apply torque from the engine to the drive axle, the torque is transferred to the track and pulls it forward. That energy enters the suspension system at the rear axle and tries to pull it forward (force "C" in following illustration). The rear arm is a pivoting or sliding linkage that only provides vertical forces at the rear of the chassis, therefore, none of force "C" enters the chassis at the rear arm.

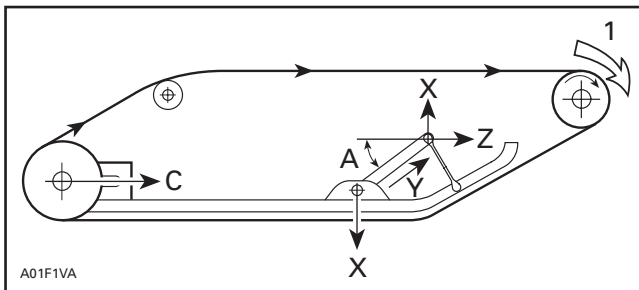

1. Drive axle torque

The front arm is mounted with a pivot to both the runners and the chassis. It is through this arm that the major reaction to the engine torque is applied. As the front arm begins to swivel from the load of force "C", it pushes down on the front of the track (force "X" in illustration). This reduces weight on the skis and applies more weight on the track for better traction. The rest of the force "C" enters the chassis through the front arm and accelerates the vehicle (force "Z").

If we keep force "C" constant, we can then vary the size of the vertical and horizontal forces at the front arm by varying angle "A". As angle "A" is made smaller, force "X" decreases, and force "Z" increases. This reduces the amount of torque reaction and more weight stays on the skis. As angle "A" is increased, force "X" increases. The skis then tend to lift more during acceleration and more weight is placed on the track.

We can vary angle "A", within limits, by adjusting the length of the limiter strap. The limiter strap is just that, a strap to limit the extension of the front of the suspension. Shortening the strap decreases angle "A" and is what we would do to set up a machine for more ski pressure. For more track pressure we would want to lengthen the strap to increase angle "A". The limiter adjustment has the largest affect on controlling the amount of weight transfer.

NOTE: Track tension must be checked whenever a major change is made to the limiter length.

Front arm spring pressure will also affect weight transfer. A stiffer spring and/or more preload will transfer more weight to the track. A softer spring and/or less preload will keep more weight on the skis. Springs must also be selected to provide absorption to the intended size of bumps to be encountered. A soft spring will increase ski pressure but may **bottom out** on large bumps, while a stiff spring will provide more track pressure but may produce a harsh ride.

NOTE: In this and other Ski-Doo texts, we refer to the front arm of the rear suspension and it's spring and shock absorber, as the center of the vehicle. The ski suspension is considered the front of the vehicle and the rear arm of the rear suspension and it's spring(s) and shock(s) are indicated as the rear of the vehicle.

Also, think of the center arm as a pivot point. During acceleration the rear arm will want to compress and the front suspension will want to extend (possibly raising the skis off the ground). Because of this **pivoting** affect, the rear spring and preload will also affect weight transfer (to a lesser amount than center arm changes). A softer rear spring and/or less preload will allow more weight transfer to the track and less ski pressure, while stiffer rear springs and/or more preload will allow less weight transfer to the track and more ski pressure.

Contrary to popular belief, it is not necessary to have the skis 2 feet off the ground to achieve good weight transfer. In fact, the energy used to lift the front of the vehicle is not available to push the vehicle forward.

The main function of the rear arm is to support the weight of the vehicle and rider, yet provide usable travel to absorb bumps and jumps. The springs are chosen depending on the linkage design of the rear arm and the intended load to be applied. Stiffer springs will be used on vehicles intended to carry heavier loads and on vehicles that plan to encounter large bumps, while vehicles used for lighter loads and on smaller bumps will use softer springs.

Springs for the front suspension are chosen in a similar fashion. A softer spring will provide less ski pressure and will be used on lighter vehicles while stiffer springs will provide more ski pressure and be used on heavier vehicles.

NOTE: Shock absorber valving and the type of shock used will also affect weight transfer. Refer to the shock absorber section for details.

A.C.M.

The SC-10 High Performance and Cross Country Rear Suspensions incorporates the use of A.C.M. technology. Under hard acceleration, the A.C.M. linkage couples the front and rear arms moving the rails rearward, thus reducing ski lift. The A.C.M. can be used to increase and decrease weight transfer. Tightening the A.C.M. will decrease weight transfer. Loosening the A.C.M. will increase weight transfer.

SPRINGS

General

Generally, 2 types of springs are used on our suspensions. Coil springs and torsional springs. Refer to following illustration.

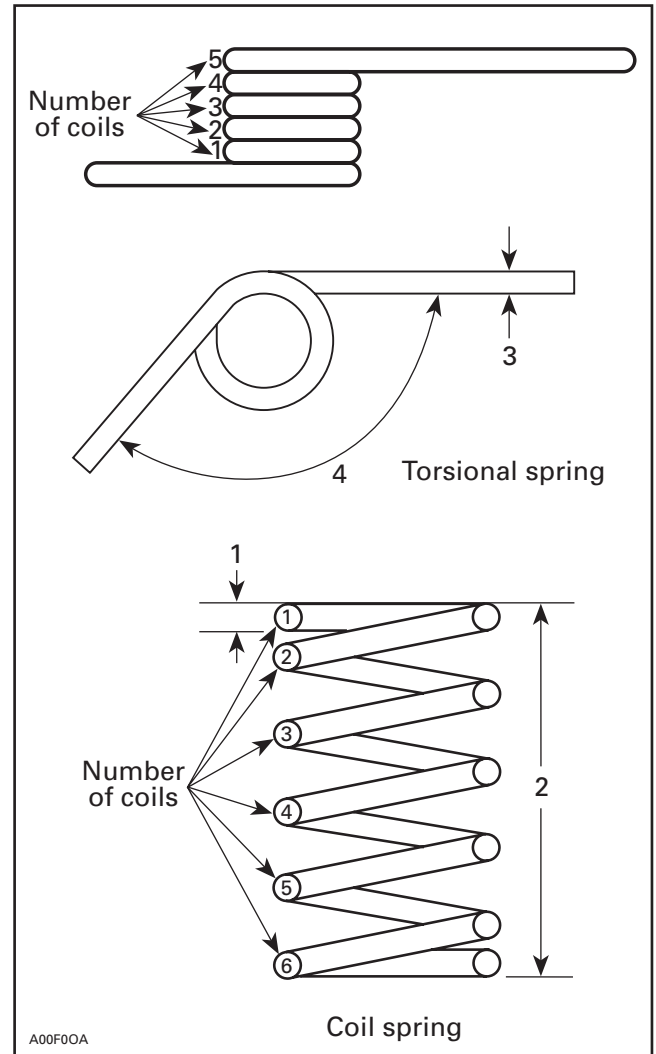

- 1. Wire diameter
- 2. Free length
- 3. Wire diameter
- 4. Opening angle

Several factors are used to determine the characteristics of a spring and they are similar for both the coil and torsional spring types. Wire diameter, material type, the number of coils and the physical shape of a spring all determine how a spring will act. Once these characteristics are built into a spring, they determine the spring rate and the free length in a coil spring or the opening angle and spring rate in a torsional spring.

SECTION 03 - CHASSIS PREPARATION

Coil Springs

The free length of a coil spring is the length with no load applied to the spring.

The spring rate of a coil spring is defined as the amount of force required to compress the spring one inch. If a 100 pound force compresses a spring 1 inch it is referred to as having a rate of 100 lbf/in (pounds per inch). If 150 pounds of force is required to compress a spring 1 inch then it would have a rate of 150 lbf/in (see following illustration).

Most springs are designed as a straight rate spring. This means that the spring requires the same force to compress the last one inch of travel as the first one inch of travel. Example: A 100 lbf/in rate spring will compress one inch for every 100 pounds applied. A force of 200 pounds will compress the spring 2 inches. A 300 pound force will compress the spring 3 inches and so on. The 150 lbf/in rate spring will require 150 pounds to compress the spring each one inch. To compress this spring 3 inches it will require a force of 450 pounds (see following illustration).

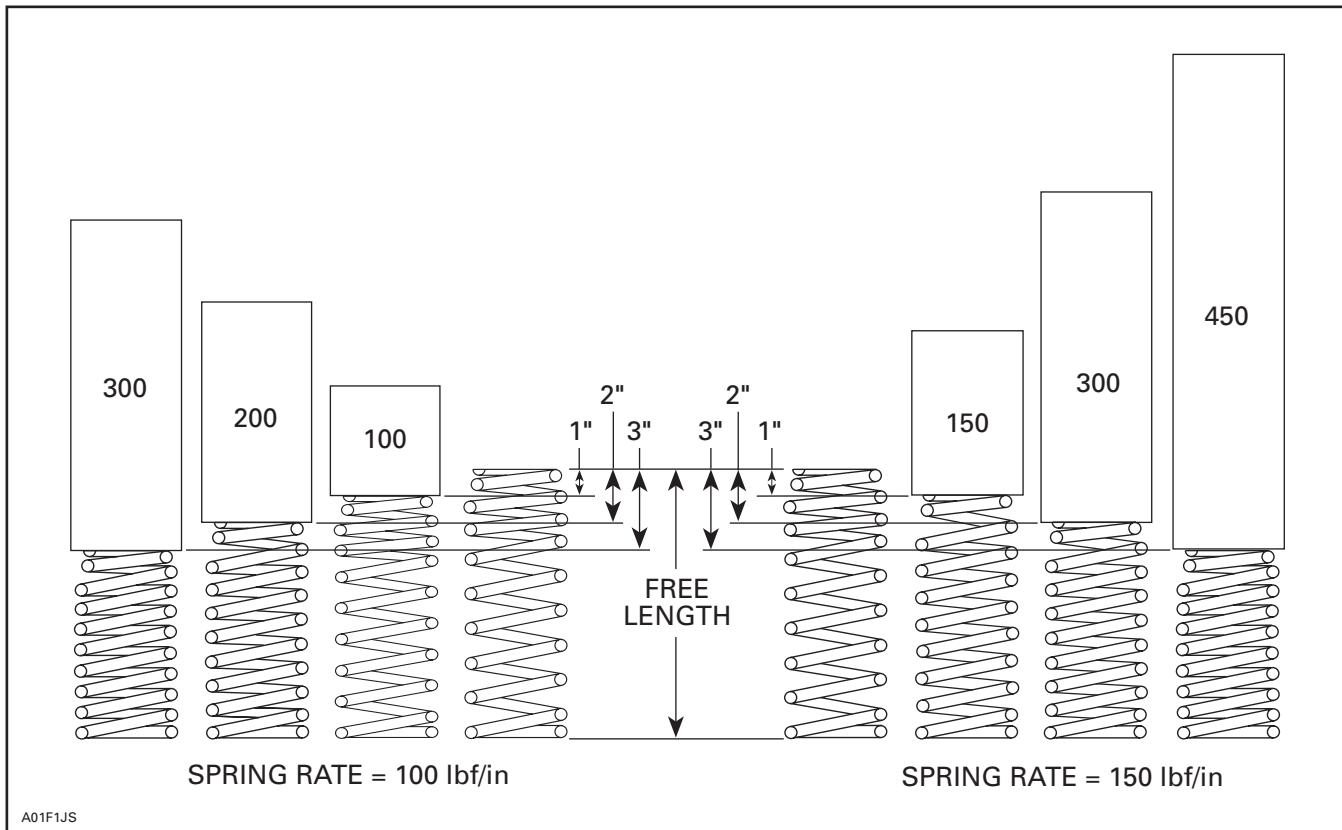
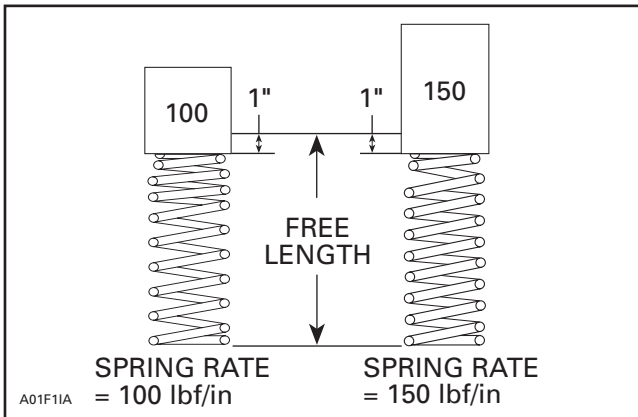

In terms of your suspension, if a bump is encountered that translates into a force at the spring of 450 pounds, the 100 lbf/in spring will want to compress 4.5 inches while the 150 lbf/in spring will only compress 3 inches. If our suspension only has 4 inches of spring travel the unit with the 100 lbf/in spring will bottom out while the 150 lbf/in unit still has 1 inch of travel remaining (see following illustration).

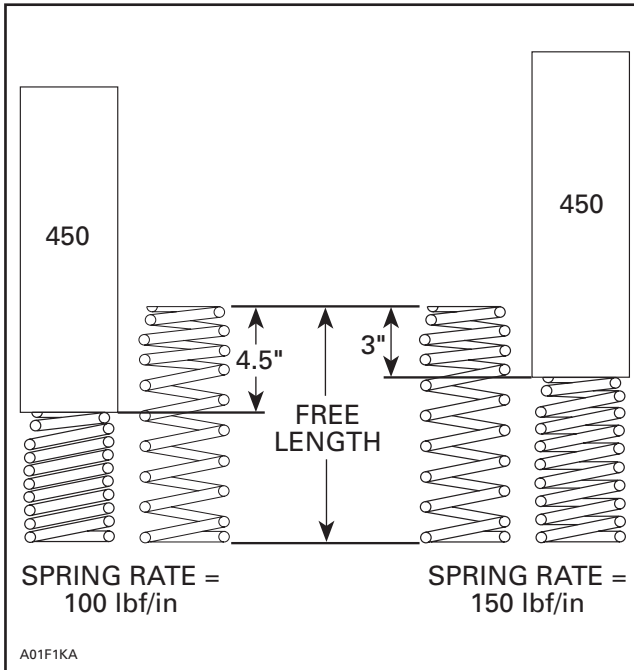

A spring can also be progressively wound. This means that the rate of the spring is increasing as it is compressed. A 100/200 lbf/in progressive spring will require 100 pounds to compress the first one inch but will require 200 additional pounds to compress the last one inch (see following illustration).

SECTION 03 - CHASSIS PREPARATION

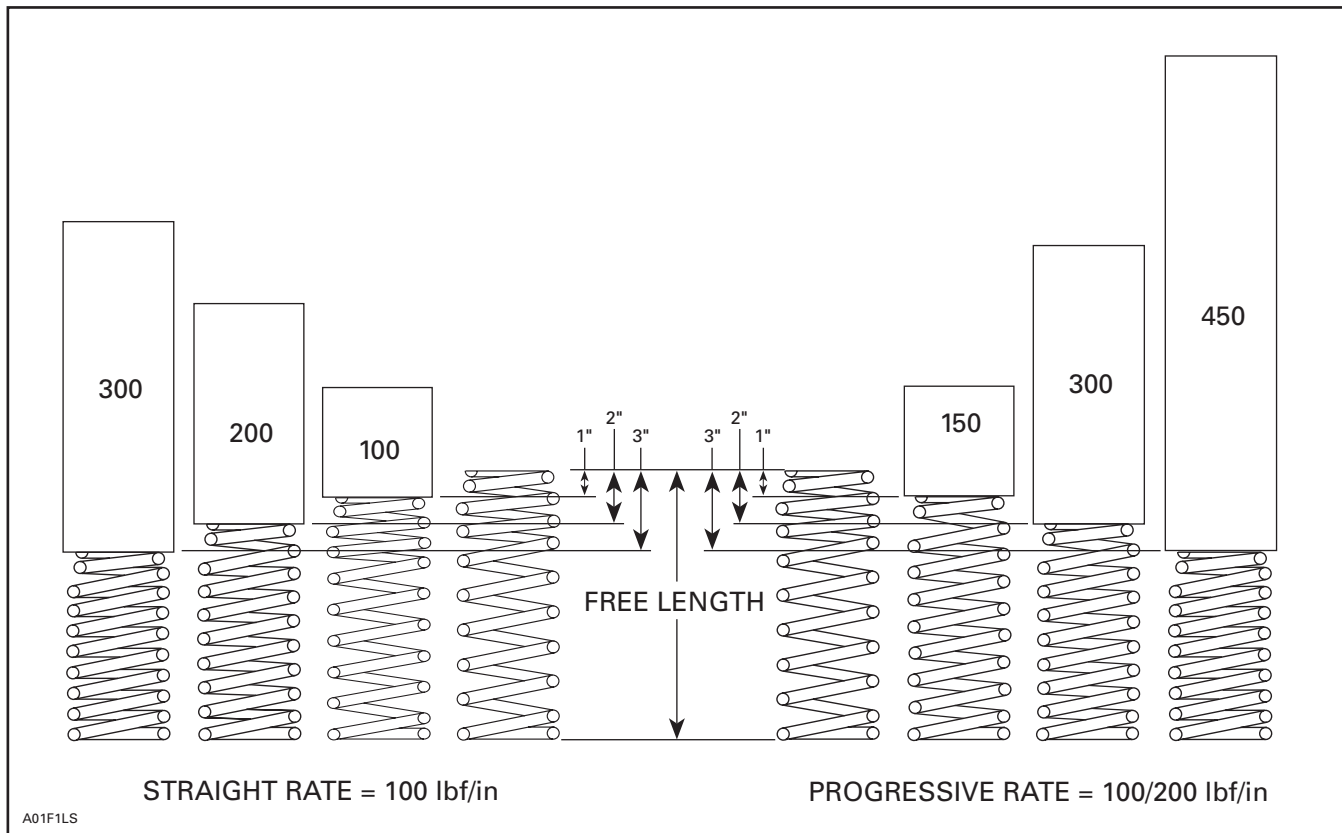

An easy way to measure coil springs is to put a bathroom scale in a press with the spring resting on the scale. Measure the free length and then apply a load until the spring compresses 1 inch. The reading on the scale will approximate the rate of the spring. Now compress the spring another 1 inch. If the spring is a straight rate, the scale reading should be doubled. If the reading is more than doubled, then you have a progressive spring. If you can compress the spring another 1 inch (3 inches total) (do not exceed maximum scale rating or damage may occur) the reading should be 3 times your first reading. In order to maintain a reasonable cost on springs, the manufacturing tolerances are quite large. A 100 lbf/in rated spring may test anywhere from 80 to 120 lbf/in.

Now, so far we have assumed that the 2 springs in our examples have the same free length and that they are not preloaded at all. In the case of our suspensions, we mount the coil springs on a shock absorber. The shock will have a certain length between the spring retainers which is called the installed length of the spring. If the installed length is less than the free length (as is the case in most applications), then there will be some preloading of the spring.

Dual Rate Spring Formula

$$\frac{\text{Spring 1} \times \text{Spring 2}}{\text{Spring 1} + \text{Spring 2}}$$

A Dual Rate Spring will assume the rate of the heavier rate spring when the lighter spring bottoms or coil binds.

Example:

Spring 1 100# Rate

Spring 2 150# Rate

$$\frac{100 \times 150}{100 + 150} = \frac{1500}{250} = 60$$

Spring 1 was a 100# Rate separately, but when stacked on the 150# spring (spring 2), it now has a 60# rate. As the spring bottoms or coil binds, it will assume the 150# rate of spring 2.

Torsional Springs

A torsional spring acts just like a coil spring but it is shaped differently. It is much more difficult to measure the rate of a torsional spring because of the lengths of the legs and where the load will be applied. The rear torsional springs on the S chassis are rated in lb-ft/degree (pounds-feet per degree of rotation). Suffice it to say that there are stiffer and softer springs for most applications.

The preload on a torsional spring is controlled by the free opening angle and the installed opening angle. If a torsional spring must be **twisted** more to be installed, then it will have more preload (following illustration).

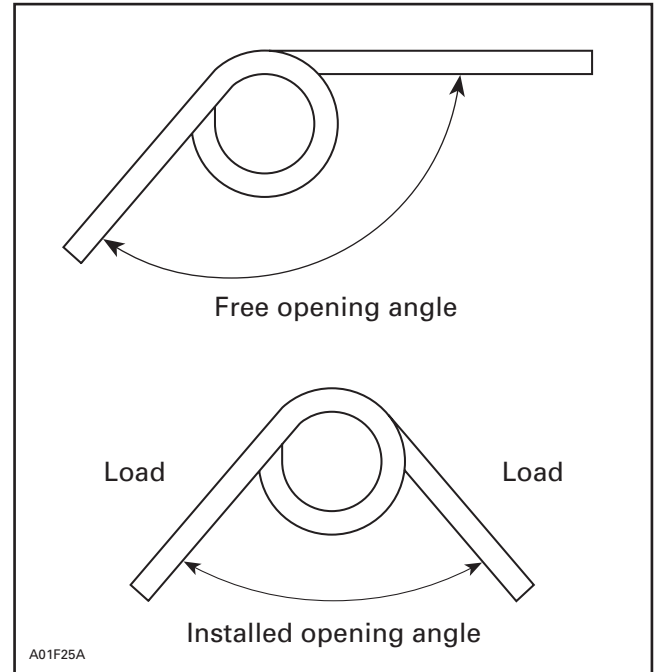

Spring Identification

Our springs will have one, 2 or 3 stripes of color painted on the spring. This is the color code used for identification. Refer to the applicable chart to find a cross reference between the part number, model application, color code, spring rate, free length and spring type. The spring type denotes physical characteristics of the spring like the inside diameter of the ends which will determine the type of retainer used to hold the spring. All spring types are not interchangeable.

CHECK THE SPRING TYPE AND FIT OF THE SPRING RETAINER BEFORE INSTALLING DIFFERENT SPRINGS!

SECTION 03 - CHASSIS PREPARATION

SPRING DESCRIPTION

COIL SPRINGS (compression)

NOTE: Read color when spring is upright and stripes are down.

Type R (straight on both ends)

(Single Rate Spring)

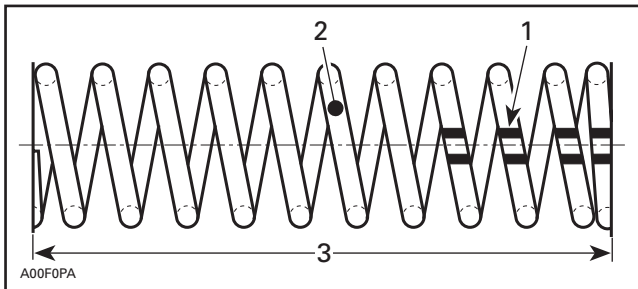

1. Color code stripes
2. Wire diameter
3. Free length

Type S (barrel shape on one end)

(Single Rate Spring)

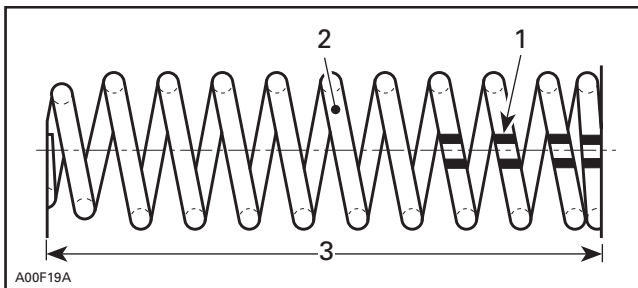

1. Color code stripes
2. Wire diameter
3. Free length

Type T (barrel shape on both ends)

(Single Rate Spring)

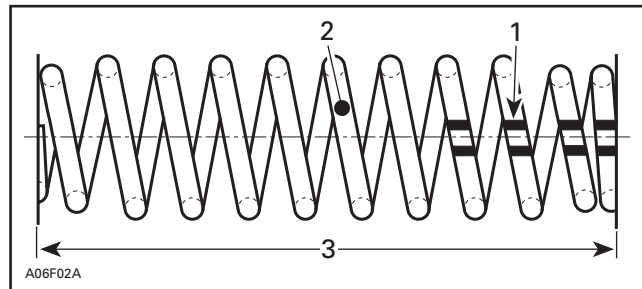

1. Color code stripes
2. Wire diameter
3. Free length

Type U (barrel shape on one end with positioning tab at the other end)

(Single Rate Spring)

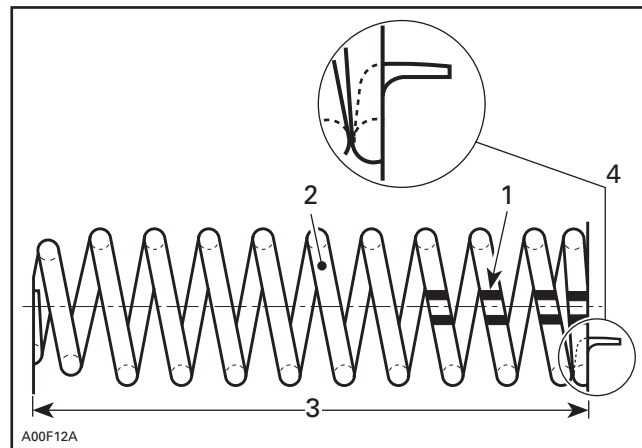

1. Color code stripes
2. Wire diameter
3. Free length
4. Positioning tab

SECTION 03 - CHASSIS PREPARATION

Type Y
(barrel shape on both ends with
positioning tab at the color code coils end)

(Single Rate Spring)

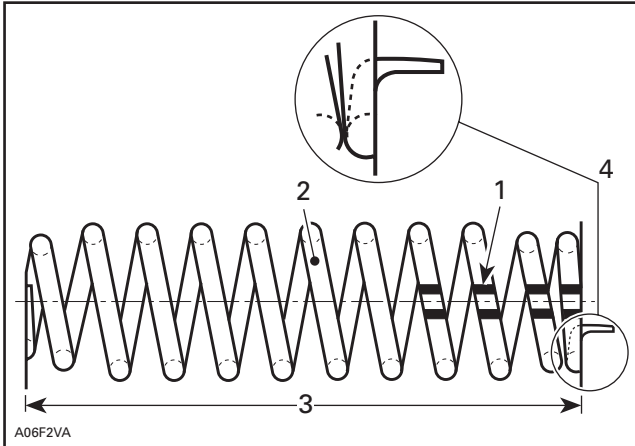

1. Color code stripes
2. Wire diameter
3. Free length
4. Positioning tab

Type 2
(barrel shape on both ends)

(Dual Rate Spring)

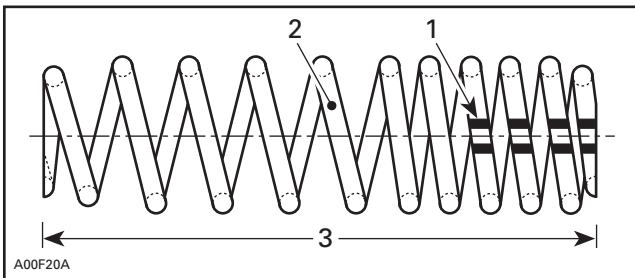

1. Color code stripes
2. Wire diameter
3. Free length

Type 4
(barrel shape on both ends with
positioning tab at the color code coils end)

(Dual Rate Spring)

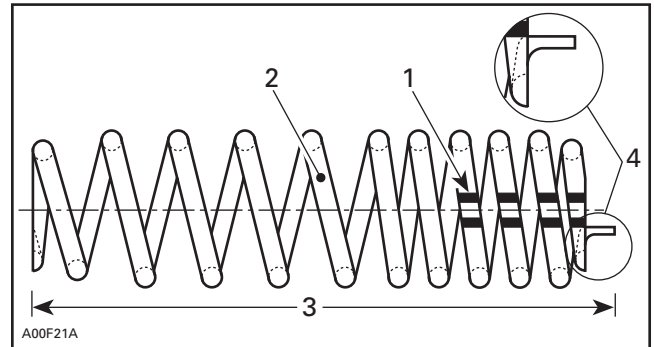

1. Color code stripes
2. Wire diameter
3. Free length
4. Positioning tab

TORSION SPRINGS

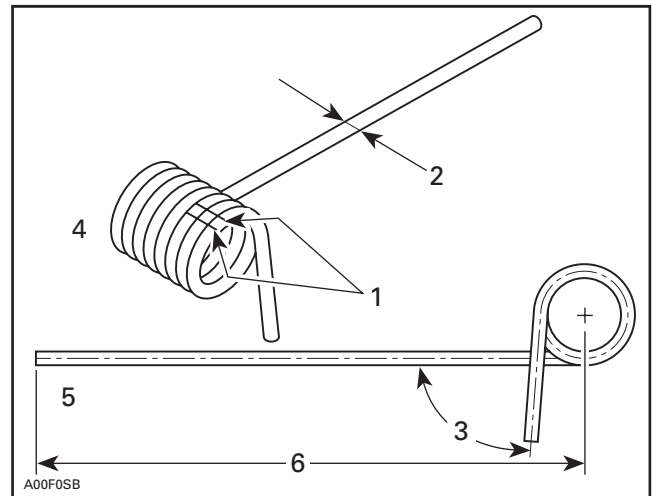

1. Color code stripes
2. Wire diameter
3. Opening angle (°)
4. Left hand (LH)
5. Right hand (RH)
6. Length

SECTION 03 - CHASSIS PREPARATION

SPRING APPLICATIONS

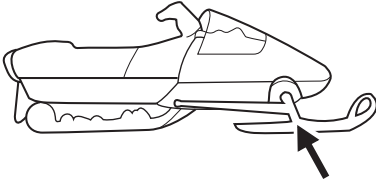
2003		FRONT SPRINGS		2003	
					
MODEL	(P/N) SOFTER SPRING	(P/N) STANDARD	(P/N) HARDER SPRING		
MACH Z	414 956 300	415 075 900	415 039 700		
MX Z SPORT	505 070 852	505 071 179	505 070 153		
MX Z ADRENALINE	Not Applicable	505 070 852	505 070 153		
MX Z TRAIL	505 070 758	505 070 393	505 070 153		
MX Zx	505 070 852	505 071 162	505 070 153		
MX Z RENEGADE	Not Applicable	505 070 758	505 070 393		
MX Z FAN	505 070 758	505 070 393	505 070 153		
SUMMIT SPORT	505 070 393	505 070 762	505 070 576		
SUMMIT X	505 070 393	505 070 760	505 070 144		
SUMMIT HM SPORT	505 070 393	505 070 762	505 070 576		
SUMMIT HM X	505 070 393	505 070 760	505 070 144		
SUMMIT HM Xtreme	505 070 393	505 070 760	505 070 144		
SUMMIT 500 F	505 070 393	505 070 762	505 070 576		
LEGEND SPORT	505 070 758	505 070 686	505 070 153		
LEGEND SPORT 4-TEC	505 070 686	505 071 129	505 070 146		
LEGEND SE	505 070 758	505 070 686	505 070 153		
LEGEND FAN	505 070 758	505 070 686	505 070 153		
GRAND TOURING SE	505 070 758	505 070 686	505 070 153		
GRAND TOURING SPORT	505 070 758	505 070 686	505 070 153		
GRAND TOURING SPORT 4-TEC	505 070 686	505 071 129	505 070 146		
TOURING FAN	505 070 758	505 070 686	505 070 153		

SECTION 03 - CHASSIS PREPARATION

2003	CENTER SPRINGS		2003
			
MODEL	(P/N) SOFTER SPRING	(P/N) STANDARD	(P/N) HARDER SPRING
MACH Z	415 070 400	415 090 500 415 090 600	415 103 600
MX Z SPORT	503 189 325	503 189 659	503 189 686
MX Z ADRENALINE	415 070 500	503 189 812	503 189 325
MX Z TRAIL	415 070 500	503 189 325	503 189 659
MX Zx	503 189 325	503 189 659	503 189 686
MX Z RENEGADE	415 070 500	503 189 812	503 189 325
MX Z FAN	415 070 100	415 070 500	503 189 325
SUMMIT SPORT	415 070 100	415 070 500	503 189 325
SUMMIT X	415 070 100	415 070 500	503 189 325
SUMMIT HM SPORT	415 070 100	415 070 500	503 189 325
SUMMIT HM X	415 070 100	415 070 500	503 189 325
SUMMIT HM Xtreme	415 070 100	415 070 500	503 189 325
SUMMIT 500 F	505 070 020	415 070 100	415 070 500
LEGEND SPORT	415 070 500	503 189 325	503 189 659
LEGEND SPORT 4-TEC	503 189 325	503 189 659	503 189 686
LEGEND SE	415 070 500	503 189 325	503 189 659
LEGEND FAN	415 070 100	415 070 500	503 189 325
GRAND TOURING SE	503 189 325	503 189 659	503 189 686
GRAND TOURING SPORT	503 189 325	503 189 659	503 189 686
GRAND TOURING SPORT 4-TEC	503 189 325	503 189 659	503 189 686
TOURING FAN	415 070 500	503 189 325	503 189 659

SECTION 03 - CHASSIS PREPARATION

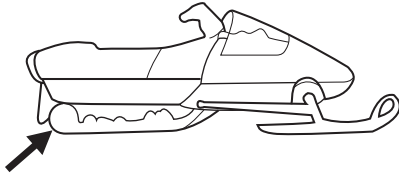
2003		REAR SPRINGS		2003	
					
MODEL	(P/N) SOFTER SPRING	(P/N) STANDARD	(P/N) HARDER SPRING		
MACH Z	503 189 629 LH 503 189 627 RH	503 189 616 LH 503 189 615 RH	503 189 524 LH 503 189 522 RH		
MX Z SPORT	503 189 594 LH 503 189 592 RH	503 189 948 LH 503 189 947 RH	503 189 904 LH 503 189 902 RH		
MX Z ADRENALINE	503 189 629 LH 503 189 627 RH	503 189 904 LH 503 189 902 RH	503 189 524 LH 503 189 522 RH		
MX Z TRAIL	503 189 629 LH 503 189 627 RH	503 189 904 LH 503 189 902 RH	503 189 524 LH 503 189 522 RH		
MX Zx	503 189 594 LH 503 189 592 RH	503 189 948 LH 503 189 947 RH	503 189 904 LH 503 189 902 RH		
MX Z RENEGADE	503 189 629 LH 503 189 627 RH	503 189 904 LH 503 189 902 RH	503 189 524 LH 503 189 522 RH		
MX Z FAN	Not Applicable	503 189 594 LH 503 189 592 RH	503 189 629 LH 503 189 627 RH		
SUMMIT SPORT	503 189 616 LH 503 189 615 RH	503 189 524 LH 503 189 522 RH	503 189 675 LH 503 189 674 RH		
SUMMIT X	503 189 616 LH 503 189 615 RH	503 189 524 LH 503 189 522 RH	503 189 675 LH 503 189 674 RH		
SUMMIT HM SPORT	503 189 616 LH 503 189 615 RH	503 189 524 LH 503 189 522 RH	503 189 675 LH 503 189 674 RH		
SUMMIT HM X	503 189 616 LH 503 189 615 RH	503 189 524 LH 503 189 522 RH	503 189 675 LH 503 189 674 RH		
SUMMIT HM Xtreme	503 189 616 LH 503 189 615 RH	503 189 524 LH 503 189 522 RH	503 189 675 LH 503 189 674 RH		
SUMMIT 500 F	503 189 629 LH 503 189 627 RH	503 189 904 LH 503 189 902 RH	503 189 524 LH 503 189 522 RH		
LEGEND SPORT	503 189 629 LH 503 189 627 RH	503 189 904 LH 503 189 902 RH	503 189 524 LH 503 189 522 RH		
LEGEND SPORT 4-TEC	503 189 616 LH 503 189 615 RH	503 189 524 LH 503 189 522 RH	503 189 675 LH 503 189 674 RH		
LEGEND SE	503 189 629 LH 503 189 627 RH	503 189 904 LH 503 189 902 RH	503 189 524 LH 503 189 522 RH		
LEGEND SE air	503 189 594 LH 503 189 592 RH	503 189 948 LH 503 189 947 RH	503 189 904 LH 503 189 902 RH		
LEGEND FAN	Not Applicable	503 189 594 LH 503 189 592 RH	503 189 629 LH 503 189 627 RH		
GRAND TOURING SE	503 189 629 LH 503 189 627 RH	503 189 904 LH 503 189 902 RH	503 189 524 LH 503 189 522 RH		
GRAND TOURING SE air	503 189 629 LH 503 189 627 RH	503 189 524 LH 503 189 522 RH	503 189 675 LH 503 189 674 RH		
GRAND TOURING SPORT	503 189 524 LH 503 189 522 RH	503 189 994 LH 503 189 992 RH	503 189 900 LH 503 189 898 RH		
GRAND TOURING SPORT 4-TEC	503 189 524 LH 503 189 522 RH	503 189 900 LH 503 189 898 RH	503 189 683 LH 503 189 681 RH		
TOURING FAN	503 189 629 LH 503 189 627 RH	503 189 524 LH 503 189 522 RH	503 189 675 LH 503 189 674 RH		
TUNDRA R	Not Applicable	414 880 200 LH 414 880 300 RH	503 189 252 LH 503 189 251 RH		

LH = Left Hand RH = Right Hand

SPRING SPECIFICATIONS

Coil Springs Specifications

P/N	TYPE	SPRING RATE (lb/in) ± 10	FREE LENGTH (mm) ± 3	WIRE DIAMETER (mm) ± .05	COLOR CODE STRIPES	COLOR OF SPRING
414 859 300	R	90 ± 7	239	7.14	BK/WH	YELLOW
415 039 700	R	150	258	8.71	PI	BLACK
415 057 500	R	160	264	8.71	RD/GD	BLACK
415 075 900	R	125	262	7.92	BL/RD/BK	YELLOW
415 069 900	T	115	265	7.49	SI/YL/YL	BLACK
415 070 400	T	115	270	8.25	GN/YL/YL	BLACK
415 070 500	T	135	242	8.41	BL/YL/YL	BLACK
415 090 500	R	293	45	6.17	YL/BL/YL	BLACK
415 090 600	S	220	210	9.19	RD/BL/YL	BLACK
415 103 600	T	135	264	8.25	GN/GN/YL	BLACK
486 130 023	T	90	N.A.	N.A.	N.A.	YELLOW
486 130 024	T	120	N.A.	N.A.	N.A.	YELLOW
486 130 025	R	240	N.A.	N.A.	N.A.	BLACK
503 189 000	T	115	265	7.92	YL/GD/YL	BLACK
503 189 090	S	220	200	9.19	YL/WH/YL	BLACK
503 189 325	T	150	242	8.25	YL/SI/YL	BLACK
503 189 659	T	180	242	8.71	BL/RD/YL	BLACK
503 189 686	T	200	242	9.19	RD/SI/YL	BLACK
503 189 812	2	125 - 200	250	8.41	BL/GN/YL	BLACK
503 189 988	U	215	64	6.35	GD/GD/YL	BLACK
503 189 990	R	275	189	9.19	GD/WH/YL	BLACK
503 190 298	U	210	N.A.	N.A.	N.A.	BLACK
503 190 300	R	275	N.A.	N.A.	N.A.	BLACK
505 070 034	4	60-90	325	7.77	BL/GR/BK	YELLOW
505 070 130	R	75	410	6.17	YL/PI/YL	BLACK
505 070 144	T	100	290	8.25	RD/BK/RD	YELLOW
505 070 146	T	100	315	8.71	RD/RD/RD	YELLOW
505 070 153	2	65 - 95	340	8.25	GN/GN/BK	YELLOW
505 070 181	4	55 - 85	320	7.77	PI/BK/BK	YELLOW
505 070 233	U	125	260	7.92	PI/BL/BK	YELLOW
505 070 240	T	90	265	7.49	RD/PI/BK	YELLOW
505 070 298	2	70 - 100	340	8.25	BL/PI/BK	YELLOW
505 070 300	U	150	260	8.71	GR/PI/BK	YELLOW

SECTION 03 - CHASSIS PREPARATION

P/N	TYPE	SPRING RATE (lb/in) ± 10	FREE LENGTH (mm) ± 3	WIRE DIAMETER (mm) ± .05	COLOR CODE STRIPES	COLOR OF SPRING
505 070 302	U	100	265	7.14	OR/PI/BK	YELLOW
505 070 305	T	105	250	8.25	RD/OR/BK	YELLOW
505 070 392	2	55-85	320	7.77	RD/GD/YL	BLACK
505 070 393	2	55 - 85	320	7.77	RD/BL/RD	YELLOW
505 070 394	R	125	235	7.49	RD/WH/YL	BLACK
505 070 534	U	290	45	6.17	BL/WH/YL	BLACK
505 070 536	T	150	300	9.19	GR/WH/YL	BLACK
505 070 573	Y	90	250	7.77	RD/BL/GN	YELLOW
505 070 575	U	290	45	6.17	RD/BL/GD	YELLOW
505 070 576	T	150	300	9.19	RD/BL/WH	YELLOW
505 070 692	4	55 - 85	320	7.77	BL/GN/RD	YELLOW
505 070 698	R	100	239	7.14	WH/BK/BK	YELLOW
505 070 758	2	45 - 85	320	7.49	RD/GD/BK	YELLOW
505 070 760	Y	95	280	8.25	BL/GD/BK	YELLOW
505 070 762	T	105	300	8.71	GN/GD/BK	YELLOW
505 070 852	4	42 - 84	340	7.49	RD/GN/RD	YELLOW
505 070 941	T	150	315	9.52	RD/SI/BK	YELLOW
505 071 201	T	105	N.A.	N.A.	N.A.	YELLOW
706 000 068	R	68	355	7.77	GR/WH/BK	YELLOW
706 000 130	R	45	360	6.91	WH/RD/BK	YELLOW
706 000 172	R	45	345	6.91	GR/BK/RD	YELLOW
706 200 006	V	140	270	8.25	OR/BK/BK	YELLOW

SPRING COLOR CODES

BK = BLACK	BL = BLUE	GD = GOLD	GN = GREEN	OR = ORANGE
PI = PINK	RD = RED	SI = SILVER	WH = WHITE	YL = YELLOW

Part numbers with a 486 prefix must be ordered from the Valcourt Race Dept.

All others must be ordered from your local Ski-Doo dealer.

N.A.: Not Applicable

SECTION 03 - CHASSIS PREPARATION

Torsion Spring Specification

P/N	WIRE DIAMETER (mm)	OPENING ANGLE ± 7°	LENGTH (mm)	COLOR CODE
414 880 200 LH 414 880 300 RH	9.5	100°	Not Applicable	Not Applicable
486 071 100 RH 486 071 200 LH	10.3	135	400	YL/YL
486 071 300 RH 486 071 400 LH	10.3	150	400	WH/WH
486 078 500 RH 486 078 600 LH	10.0	115	400	YL/RD
486 093 200 RH 486 093 300 LH	11.5	80	400	GN/YL
486 099 100 RH 486 099 300 LH	11.89	140	385	YL/RD/YL
503 189 252 LH 503 189 251 RH	10.3	95°	502	RD/RD
503 189 339 LH 503 189 338 RH	11.11	90°	400	GN/GN
503 189 343 LH 503 189 342 RH	10.6	80°	400	RD/RD/RD
503 189 347 LH 503 189 346 RH	10.3	85°	400	YL/YL/YL
503 189 351 LH 503 189 350 RH	11.5	100°	385	GD/GD
503 189 355 LH 503 189 354 RH	10.6	90°	400	WH/WH/WH
503 189 359 LH 503 189 358 RH	11.11	80°	400	BL/BL
503 189 445 LH 503 189 443 RH	11.11	95°	385	GN/GN/GN
503 189 524 LH 503 189 522 RH	11.11	90°	385	GN/GN/YL
503 189 594 LH 503 189 592 RH	10.3	85°	385	GD/RD
503 189 616 LH 503 189 615 RH	11.11	100°	385	RD/YL
503 189 629 LH 503 189 627 RH	10.6	90°	385	YL/WH
503 189 675 LH 503 189 674 RH	11.11	80°	385	SI/YL/YL
503 189 683 LH 503 189 681 RH	11.9	80°	385	SI/SI
503 189 881 RH 503 189 883 LH	11.11	75	385	YL/BL
503 189 900 LH 503 189 898 RH	11.5	90°	385	GD/GD/GD
503 189 904 LH 503 189 902 RH	10.6	80°	385	RD/RD/YL
503 189 948 LH 503 189 947 RH	10.3	75°	385	GN/YL/YL
503 189 994 LH 503 189 992 RH	11.11	73°	385'	GN/RD/YL

LH = Left Hand

RH = Right Hand

SPRING COLOR CODES

BK = BLACK
PI = PINK

BL = BLUE
RD = RED

GD = GOLD
SI = SILVER

GN = GREEN
WH = WHITE

OR = ORANGE
YL = YELLOW

SECTION 03 - CHASSIS PREPARATION

CORNERING DYNAMICS

The ideal situation, while going through a turn, is to keep the snowmobile as flat as possible without the skis or track losing contact with the driving surface.

As you enter a corner and turn the skis, the rest of the vehicle will want to continue straight ahead. If the skis do not bite the surface, they will start slipping and the vehicle will not turn as tight as the skis are turned. This is called **understeering** or pushing. If the skis bite very well and the track starts sliding out, then the vehicle is **oversteering** or is said to be loose. If the ski and track traction is balanced, then the vehicle will maintain a good line through the corner. Because the center of gravity of the vehicle wants to continue straight ahead and because the center of gravity is above ground level, weight will be transferred to the outside of the vehicle. This causes the machine to roll to the outside. As the radius of the corner gets tighter and/or speeds increase, the machine rolls more, and more weight is transferred to the outside of the vehicle until the front or back loses traction or the vehicle tips over.

Roll can be reduced by installing stiff springs on the front suspension and/or a lot of preload, but this will cause a harsher ride than necessary. Lowering the center of gravity will also reduce roll but there are practical limits as to how low the center of gravity can go. Most vehicles are equipped with an antiroll bar or **stabilizer** bar. Common terminology will refer to it as a **sway** bar. (It is in fact an **anti-sway** bar) The bar is mounted to and pivots on the chassis. The ends of the bar have lever arms from 3" to 7" in length. The ends of the levers are connected to the front suspension. As the outside suspension is compressed during a corner, the bar is twisted and forces the inside spring to compress also. The bar is "borrowing" spring pressure from the inside spring and adding it to the outside spring. The suspension can now resist more chassis roll (see following illustration).

By having a sway bar in the suspension, softer springs can be used to achieve a good ride because the bar will help control roll in a corner. The bar has no effect on ride when traveling straight ahead over bumps that are even from side to side. However, if only one ski encounters a bump, then the bar will transfer energy between the springs. This leads to another design decision. The diameter of the sway bar determines how much spring pressure will be **borrowed** from the opposite spring. A smaller bar will twist more and not transfer as much energy. A larger diameter bar will transfer more energy which will reduce chassis roll, but will produce a harsher ride on uneven, bumpy terrain. A smaller diameter bar will give a more compliant ride on the nasty bumps but it will allow the chassis to roll more in corners. A cross country sled will use small to medium diameter bars while oval and lemans racers will use large diameter bars.

The length of the lever arm also affects the **stiffness** of the sway bar. A shorter lever will **stiffen** the bar and a longer lever will **soften** the bar. Many lever arms will have 2 holes to mount the connector linkage. The hole closest to the bar will act stiffer.

When changing the sway bar diameter you must also change the ball joint blocks and bushings.

For snowcross racing some racers prefer to disconnect the sway bar. This will let the front suspension act more independently, as the suspension is no longer coupled.

Another little known fact that has a large effect on roll is the limiter strap length. As mentioned earlier, if the limiter is lengthened, the front suspension will extend during acceleration, which reduces ski pressure. If this vehicle was in a corner when power was applied, it would have quite a bit of chassis roll and the inside ski will start to lift off of the ground. Shortening the limiter will have a very large effect on controlling roll. A general guideline for initially setting limiter length for good ski pressure and reducing roll is to have the front and back of the track touch the ground at the same time when you set the back of the vehicle down. If the front of the track touches much sooner than the rear, there will be quite a lot of weight transfer and chassis roll during hard cornering.

SHOCKS

Valving and Dampening

In the HPG shock, the piston passages are covered by a stack of thin metal shims of various thicknesses and diameters. The shims provide dampening by acting as spring loaded valves offering resistance to the oil traveling through the piston. There is a stack of shims on both sides of the piston. One side controls compression dampening and the other side controls rebound dampening. By varying the number and thickness of shims the dampening characteristics can be very accurately obtained. There may also be orifices or slits in the piston that are not covered by the shims. These are referred to as bleed slits. The size and number of these slits will also affect dampening. The external adjustment on the MVA, HPG shocks is a variable bleed hole.

Rebound dampening will usually be much stiffer than compression dampening. This is because rebound dampening must resist the force of the spring and because piston speeds are much slower during rebound.

At low piston speeds, the number of bleed slits will have a fairly large effect on dampening, but as piston speeds increase most of the dampening is controlled by the shim stack. This is because the flow area of the slits is much smaller than the flow area under the shims. Since only a small amount of oil can flow through the bleed slits (compared to the amount that flows under the shim stack), the slits have only a very small effect on dampening at high piston speeds. Because of this characteristic, bleed slits are most effective on rebound dampening. They will have only a very slight effect on compression damping because the typical piston speeds on compression strokes are several times faster than on rebound strokes. There really is no such thing as **high speed** rebound dampening.

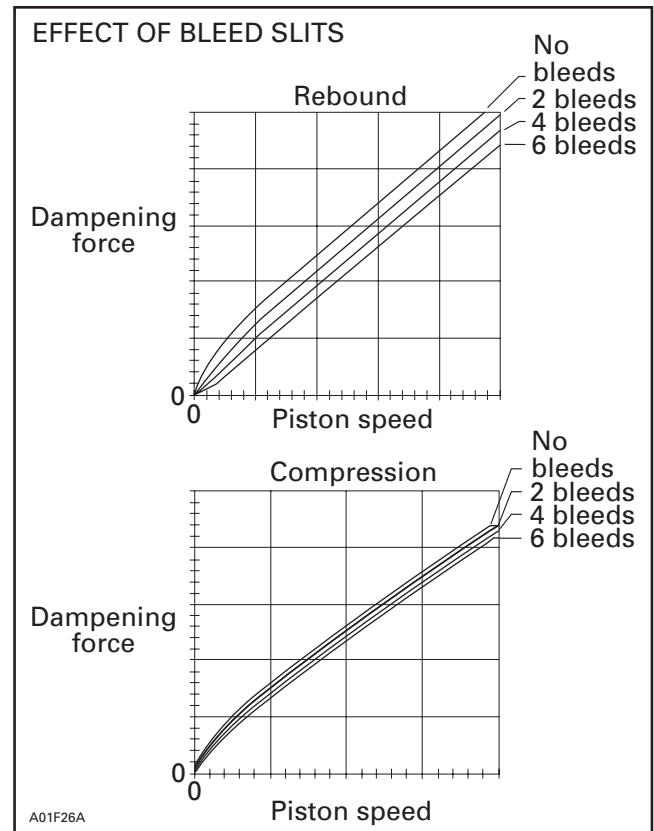

SECTION 03 - CHASSIS PREPARATION

As mentioned earlier, the configuration of the shim stack will control most of the dampening of the shock. There are several methods to tuning shim stacks. The first and most commonly used is to increase or decrease the overall stiffness of the stack. This can be done by changing the number of large shims or by increasing or decreasing their thickness.

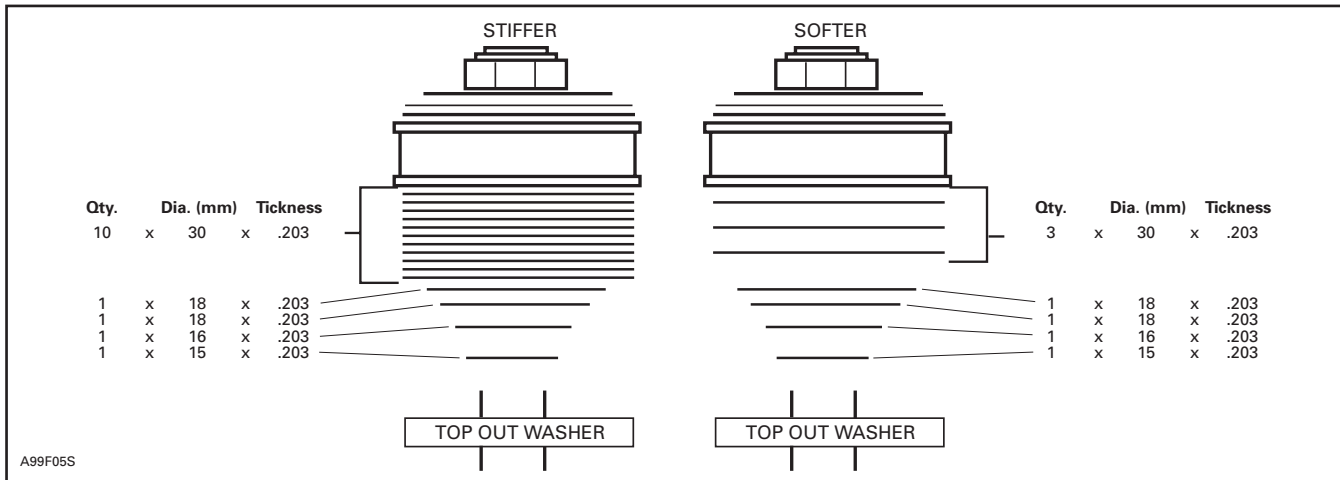

The overall stiffness of the stack has been increased by adding 7-30 mm x .203 mm shims. This will result in firmer dampening at both low and high piston speeds. Thicker shims will also result in firmer dampening but it is better to use more thin shims than fewer thick shims. More thin shims will provide better, smoother dampening than a few thick shims. There is an equivalency between thick and thin shims, though. The following chart indicates how many thin shims are required to equal the stiffness of one thick shim.

(mm)	
1 x .152	= 2.4 x .114
1 x .203	= 2.3 x .152
1 x .254	= 2.0 x .203

This means it will take 2.4 x .114 mm shims to have the same dampening as 1 x .152 mm shim. Obviously you can't use a fraction of a shim so you must find the lowest common denominator. For 2.4 it will be 5. For 2.3 it will be 10. The following chart shows the most common possibilities.

(mm)	
5 x .152	= 12 x .114
10 x .152	= 24 x .114
10 x .203	= 23 x .152
1 x .254	= 2 x .203
2 x .254	= 4 x .203
3 x .254	= 6 x .203
4 x .254	= 8 x .203
5 x .254	= 10 x .203
6 x .254	= 12 x .203
7 x .254	= 14 x .203
8 x .254	= 16 x .203
9 x .254	= 18 x .203
1 x .305	= 2 x .254
2 x .305	= 3 x .254
3 x .305	= 5 x .254
4 x .305	= 7 x .254
5 x .305	= 9 x .254
6 x .305	= 10 x .254

The diameter of the smaller shims that support the large shims will also affect the dampening. A larger support shim gives more support to the large shim thus making it act stiffer. Conversely, a smaller diameter support shim will allow the large shim to bend more easily thus softening the dampening. The following graph shows the effect of different diameter support washers.

SECTION 03 - CHASSIS PREPARATION

Shim Comparator Formula

Thickness³ or cubed.

Example: .152 x .152 x .152

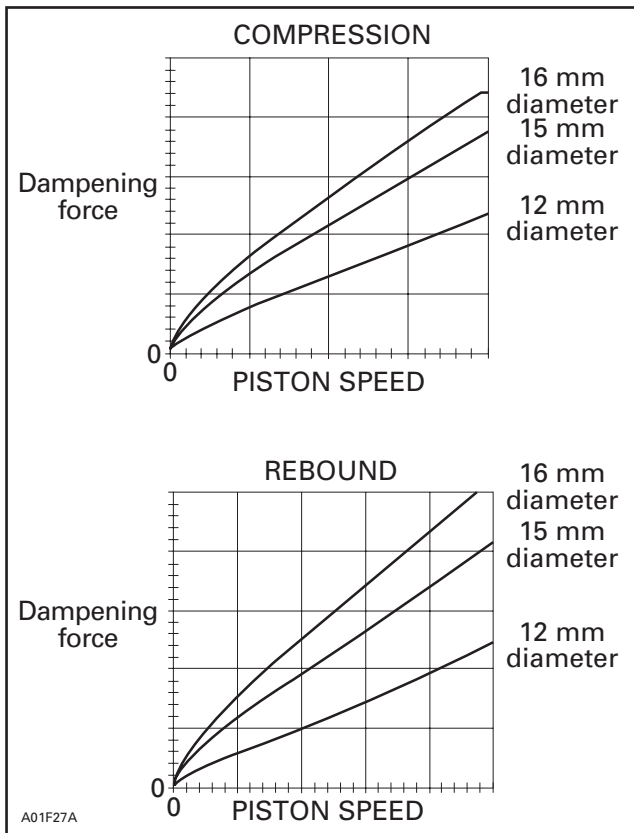

Another method of changing dampening is by controlling the amount of space the stack has to open. This is done by reducing the amount of smaller shims which support the larger shims. The larger shims act the same until they bottom out against the valve stopper.

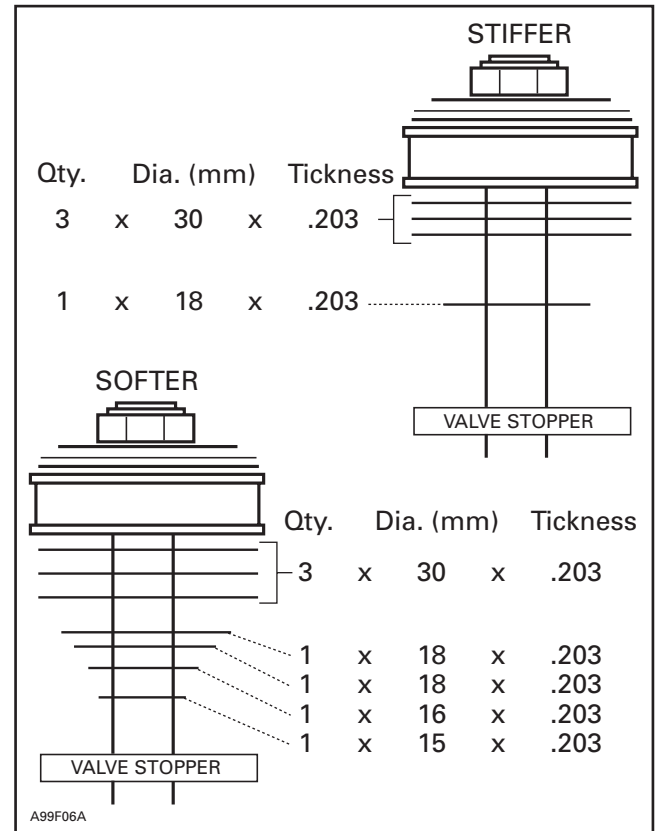

The large shims are only able to deflect .203 mm instead of .610 mm thus reducing the flow area of the piston. This will result in the same low speed dampening, but the medium and high speed dampening will be increased. The following graph represents the effect of changing the total thickness of small shims which determine the amount of large shim deflection.

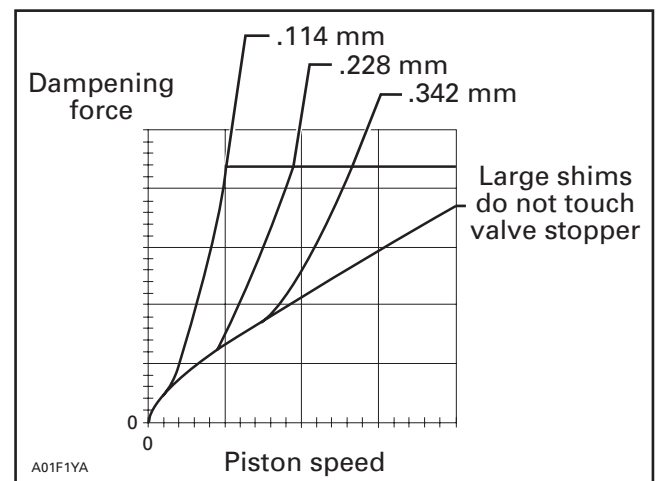

SECTION 03 - CHASSIS PREPARATION

As you can see, low speed dampening remains the same until the shim stack bottoms out against the valve stopper. Then the dampening becomes significantly stiffer. This is sometimes referred to as progressive dampening. Another similar way to achieve this type of dampening is to use multiple stacks of large and small shims.

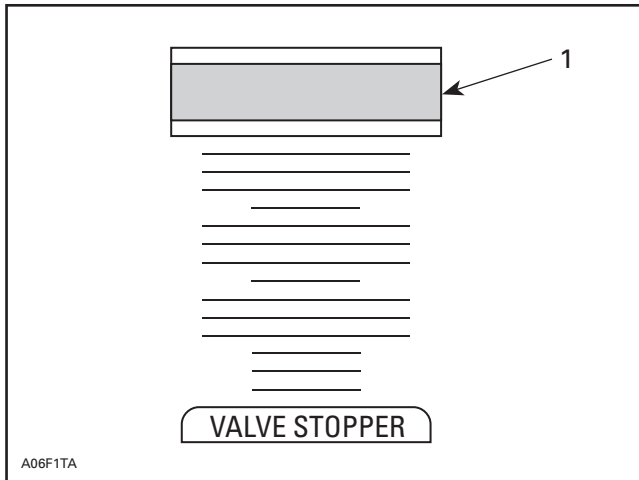

1. Piston

The first stack of large shims will deflect very easily thus giving soft low speed dampening. The number of small shims will determine when the first stack hits the second stack of large shims. Now both stacks are acting together thus stiffening the dampening. This can be repeated several times until the complete stack of large shims bottoms out against the valve stopper.

As you can see, there are an unlimited number of valving combinations and many different versions will achieve very similar results. The following general guidelines should help reduce your tuning time.

- If the dampening is close to what you want, just add or remove 1 or 2 large shims, from the appropriate side, to fine tune the overall stiffness.

NOTE: Always use 30 mm diameter shims against the piston for compression dampening and 26 mm diameter shims against the piston for rebound dampening. Excludes C-46 shock.

- Generally, rebound dampening should not be changed unless a large change in spring rate is made.

- Bleed slit quantity will affect low speed dampening.
- Under dampening may be due to an aerated shock due to low gas pressure and/or old, used oil. Change the oil and recharge the gas pressure to 300 PSI before altering the shock valving.
- If the vehicle bounces or **pogos** a lot, the problem may be too little compression dampening NOT too little rebound dampening. Do not use too much rebound dampening! Excessive rebound dampening is a common error. Overdampening will not allow the suspension to recycle to full extension after an obstacle compresses the suspension. This situation (called packing) will eventually bottom the suspension and not allow it to cycle properly.
- For faster weight transfer under acceleration and deceleration, use a piston with more bleed slits.

Shock Oil and Nitrogen

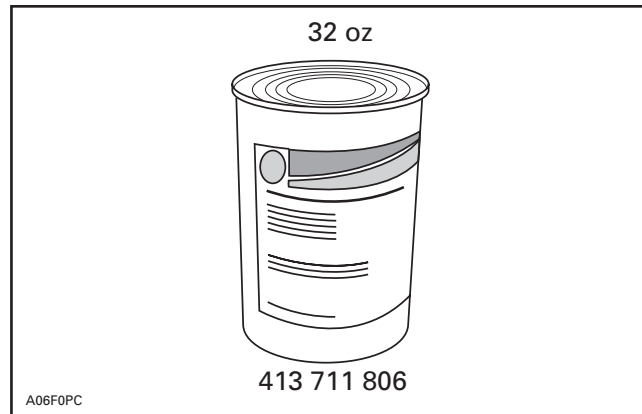

SECTION 03 - CHASSIS PREPARATION

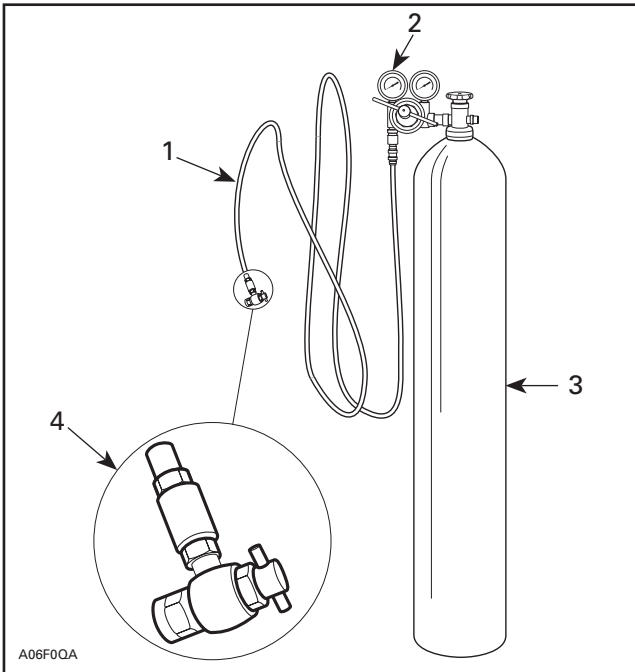

1. Automotive type air pressure hose
2. 2 stage regulator, delivery pressure range 2070 kPa (300 PSI)
3. High pressure cylinder filled with industrial grade nitrogen
4. Valve tip (P/N 529 035 570)

NOTE: Commercially available through compressed gas dealers.

Disassembly and Assembly

Release N₂ (nitrogen) pressure from the damper Schrader valve on any HPG T/A with IFF.

NOTE: When rebuilding a gas emulsion shock, mount the shock vertically in a vice with the schrader valve up and let it sit for 5 minutes before releasing the gas. This 5 minute period will allow most of the gas to separate from the oil and minimize oil spray.

WARNING

Nitrogen gas is under extreme pressure. Use caution when releasing this gas volume. Protective eye wear should be used.

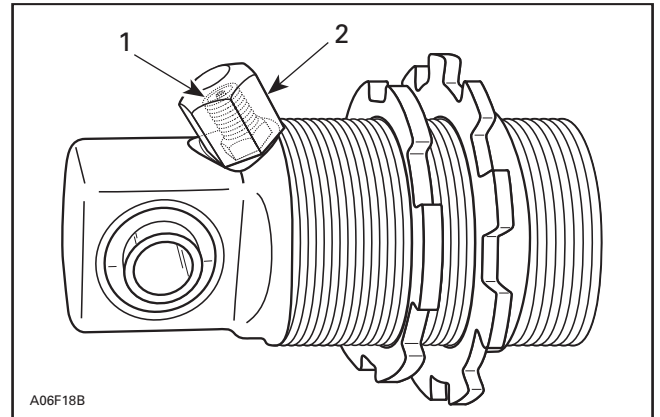

1. Schrader valve 1.5-2 N•m (13-17 lbf•in)
2. Schrader cap 5-6.5 N•m (44-57 lbf•in)

NOTE: Before unscrewing pre-load rings, measure the compressed length of the installed spring and mark position for reinstallation. For factory adjustment refer to the end of this section.

Use tools (P/N 861 743 900) to remove damper spring by unthreading spring pre-load rings, then removing spring retainer or use the spring removal tool (P/N 529 035 504).

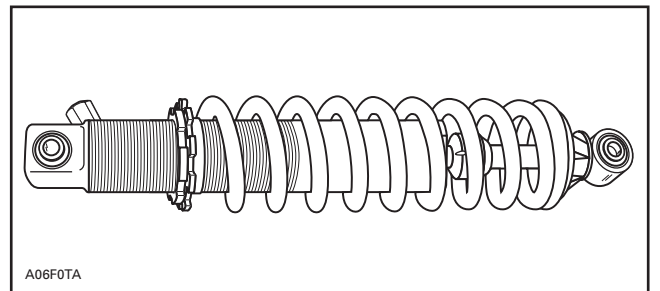

TYPICAL

SECTION 03 - CHASSIS PREPARATION

Holding damper assembly in bench vise with aluminum jaw protectors, unthread seal assembly from damper body using a 32 mm (1.25 in) spanner wrench. This assembly uses a right hand thread.

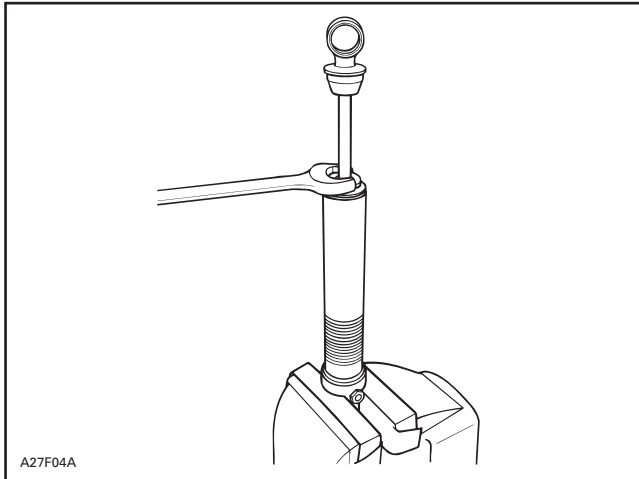

With the seal assembly removed, slowly lift and remove damper rod assembly from the damper body.

NOTE: Remove damper rod assembly slowly to reduce oil spillage and prevent piston seal damage by damper body threads. Wrap the damper body with a shop cloth to capture possible overflow oil while removing the damper piston.

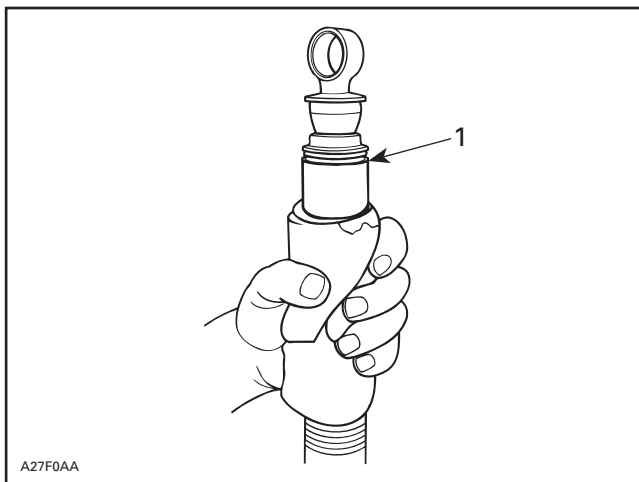

1. Oil flows

Discard old oil into storage container. Never reuse damper oil during shock rebuild.

Remove Schrader valve core. Using compressed air pressure, carefully remove floating piston from damper body. Hold shop cloth over damper body opening to catch released floating piston. Allow room for floating piston to leave damper body.

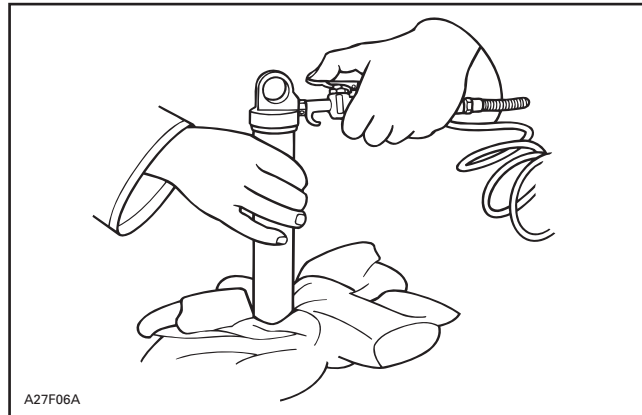

TYPICAL

WARNING

Whenever using compressed air, use an O.S.H.A. approved air gun and wear protective eye wear.

Thoroughly clean, with a typical cleaning solution, and blow dry using low pressure air. Carefully inspect the damper body for any imperfections or signs of wear in the damper bore.

Replace damper body if wear is identified.

Holding the damper rod assembly in a bench vise, begin piston and valve removal.

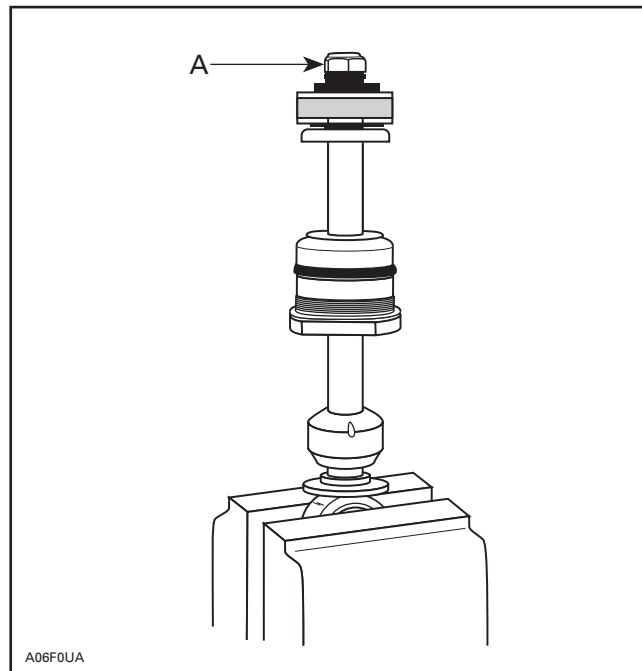

A. Remove damper nut

SECTION 03 - CHASSIS PREPARATION

Always arrange parts removed in the sequence of disassembly.

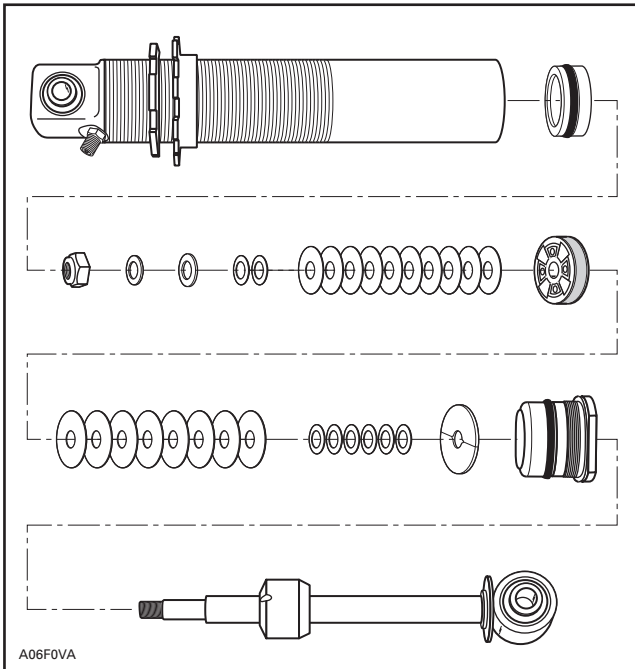

NOTE: As a general rule we suggest replacing the damper rod lock-nut after 4 rebuilds to ensure good locking friction and use Loctite 271 each time.

NOTE: If revalving is to be done, it is imperative that you identify the original shim pack (size and number of shims). The seal carrier need not be removed if only revalving is to be done.

Shims can be measured by using a vernier caliper or a micrometer.

NOTE: All shims should be carefully inspected and any bent or broken shims must be replaced for the shock to function properly.

The damper rod is constructed of a plated shaft design. This damper shaft must be inspected for any visible wear on the surface of the damper rod.

Another check that must be completed if damper seal leakage has been noticed, is damper rod run-out. This damper rod run out must not exceed 0.25 mm (.001 in).

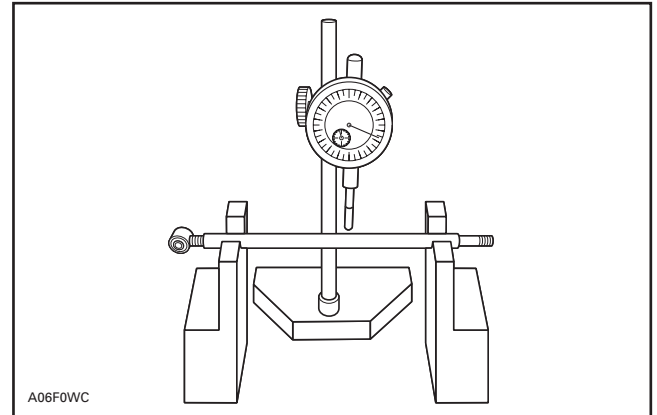

MAXIMUM DEFLECTION 0.025 mm (.001 in)

After the new or replacement shim pack has been selected, reassemble in the reverse order of disassembly. Torque piston nut 11-13 N•m (96-108 lbf•in). Use 271 Loctite.

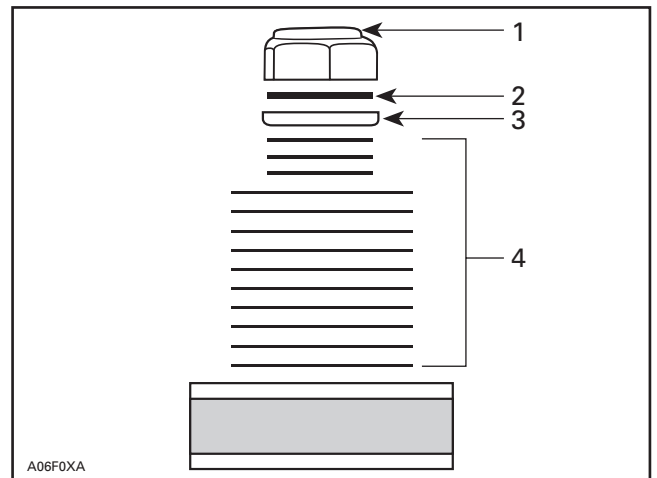

1. Damper nut
2. Spacer
3. Washer
4. Shim pack

CAUTION: The damper rod nut can only be re-used 4 times, then, must be replaced. Do not substitute this part for non – O.E.M. use Loctite 271 on nut each time.

This spacer washer(s) (P/N 414 888 309) must be used as shown to ensure damper rod nut does not bottom out or contact shaft threads.

Rebound valve stopper with round edge facing shim stack.

SECTION 03 - CHASSIS PREPARATION

NOTE: Rebound shim stack must not reach into threads of damper shaft. Washer under damper shaft nut is used to prevent damper shaft nut from bottoming on threads.

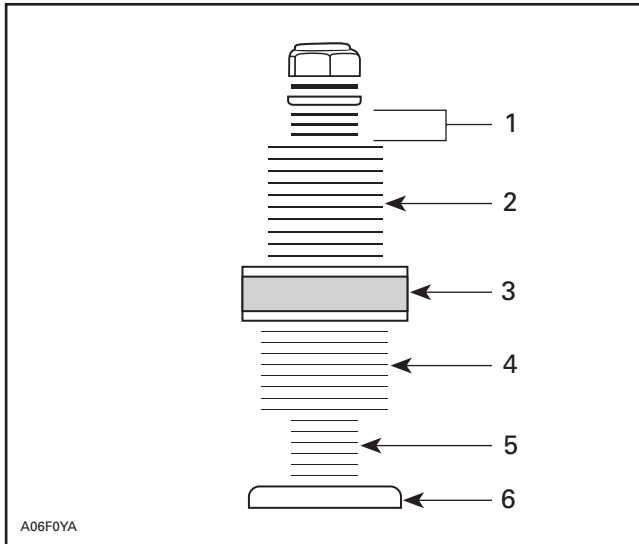

1. Rebound dampening shim pack
2. Rebound dampening shim pack
3. Piston
4. Compression dampening shim
5. Compression dampening shim pack
6. Stopper

Rebound

A minimum of 0.203 mm (.008 in) clearance must be allowed between shim stack and rebound valve stopper. Use at least one shim of 12 × .203 mm.

Whenever tuning for more rebound damping always use 26 mm (1.02 in) shims against piston to properly close piston orifice holes. More thin shims will offer more control than a few thick shims of the same overall thickness.

NOTE: When tuning for less dampening it is important to remember, never use less than 3-26 mm (1.02 in) shims against piston. This will guard against fatigue breakage.

Piston options include 5 pistons; 0, 1, 2, 4 and 6 slits for rebound dampening bleeds.

Compression

Whenever tuning for more compression dampening always use 30 mm (1.18 in) shims against piston to properly close piston orifice holes. Two thin shims will offer more control than one thick shim of the equal thickness.

NOTE: When tuning for less dampening it is important to remember, never use less than 3 shims against piston. This will guard against fatigue breakage.

Fewer spacer shims will result in more high speed dampening. A minimum of 0-114 mm (.0045 in) clearance should be allowed between shim stack and compression valve stopper. Use at least one shim of 12 × .114.

If the seal carrier assembly is replaced, use seal pilot to guide seal over damper shaft. Lubricate seal carrier guide pilot before use.

CAUTION: Failure to use seal pilot will result in seal damage.

Reassemble damper rod assembly, taking care to properly assemble shim packs as required for your dampening needs. Ensure that the shaft piston is installed with the slits/larger intake holes facing the rebound shim stack.

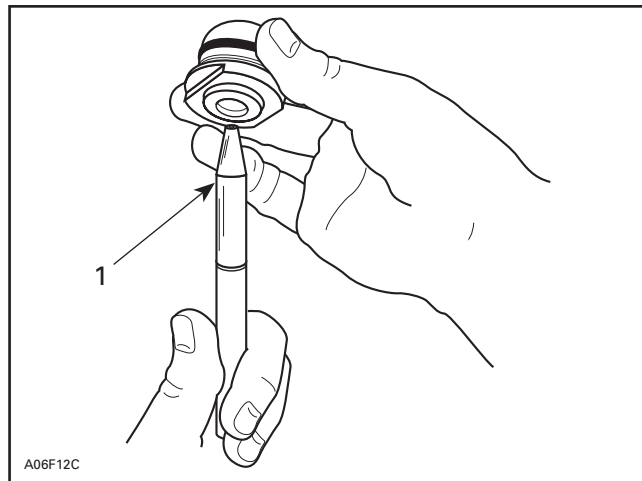

1. Pilot (P/N 529 026 900)

SECTION 03 - CHASSIS PREPARATION

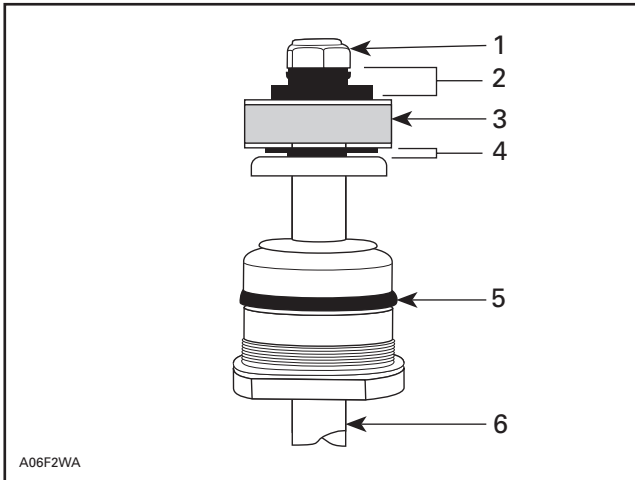

1. Damper nut torque 11-13 N•m (96-108 lbf•in) use Loctite 271
2. Rebound shim pack
3. Piston
4. Compression shim pack
5. O-ring visual inspection seal carrier assembly
6. Damper rod

Reinstall floating piston into damper body (ensure that Schrader valve core has been removed). Use molybdenum disulfide grease (example: molykote paste (P/N 413 703 700) or silicone grease Dow Corning MS4 (P/N 420 897 061) to ease O-ring past damper body threads with floating piston pilot (P/N 529 026 600).

CAUTION: Failure to install IFP correctly could result in shock damage.

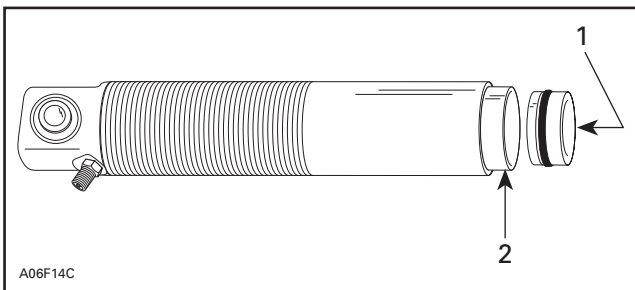

1. Push (slowly) by hand
2. Floating piston guide (P/N 529 026 600)

NOTE: Lubricate inside of piston guide with molykote GN paste (P/N 413 703 700) or MS4 silicone grease (P/N 420 897 061).

Install floating piston to the proper depth.

On all HPG take apart shocks from 1996 on. The floating piston is installed hollow side up.

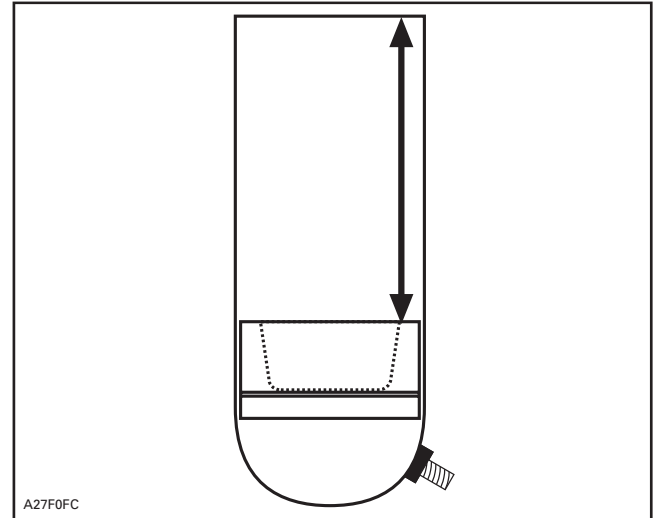

Required distance for floating piston installation.

NOTE: If the floating piston is installed too far into the damper body, light air pressure through Schrader valve (with core removed) will move piston outward.

NOTE: Reinstall Schrader valve core after IFP has been installed at correct height and before adding oil.

⚠ WARNING

Whenever using compressed air exercise extreme caution, cover damper opening with shop cloth to reduce chance of possible injury.

CAUTION: Moisture laden compressed air will contaminate the gas chamber and rust floating piston.

⚠ WARNING

Always wear protective eye wear whenever using compressed air.

SECTION 03 - CHASSIS PREPARATION

Fill the shock with Bombardier HPG shock oil (P/N 413 711 806) to approximately 10 mm (.393 in), from the base of seal carrier threads.

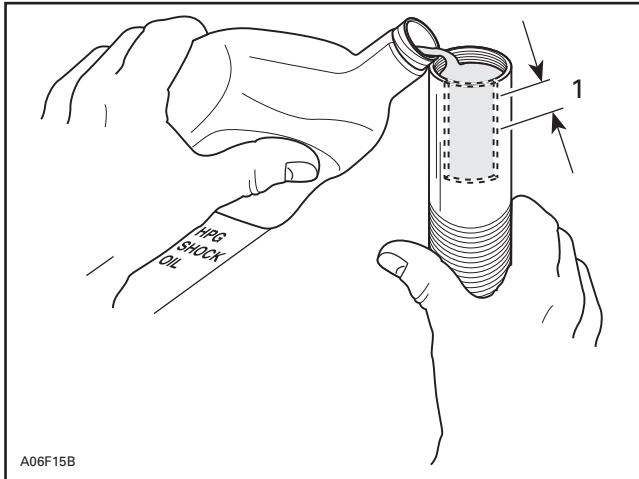

1. Fill to 10 mm (.393 in)

NOTE: Although we do not measure the exact amount of oil added to the damper, approximately 106 mL (3.58 oz U.S.) will be used.

Carefully insert damper rod into the damper body. Install damper rod assembly into the damper body. Lightly oil damper piston seal ring with shock oil to ease installation.

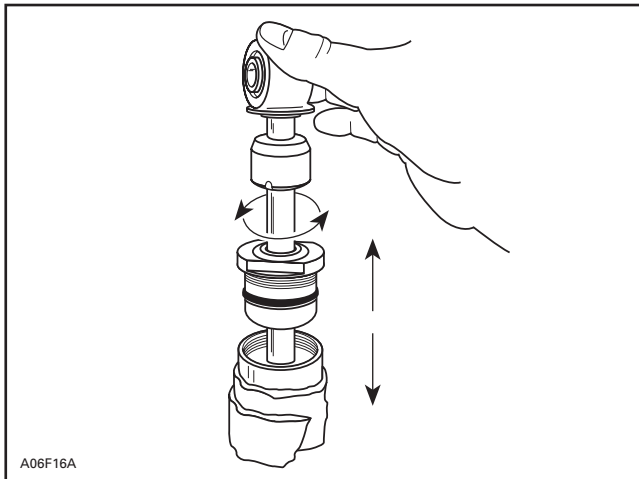

NOTE: Some shock oil will overflow when installing damper. Wrap damper with shop cloth to catch possible overflow oil.

CAUTION: Use care when passing piston into damper body at damper body threads.

Slight oscillation of damper rod may be required to allow piston to enter damper body bore.

Slowly push piston into damper body. Slight up and down movement may be required to allow all air to pass through piston assembly. The gentle tapping of a small wrench, on the shock eye, may help dislodge air trapped in the submerged piston. Be careful not to drive the shaft any deeper into the oil than is necessary to just cover the shim stack.

NOTE: Fast installation of the damper rod may displace the floating piston from its original position. This must not occur if the damper is expected to perform as designed.

With damper rod piston into-oil, TOP OFF damper oil volume. Oil level should be to damper body thread base.

Seal carrier assembly can now be threaded into damper body. This should be done slowly to allow weepage of oil and to minimize IFP displacement. After the seal carrier is fully in place avoid pushing the shaft into the body until the nitrogen charge is added.

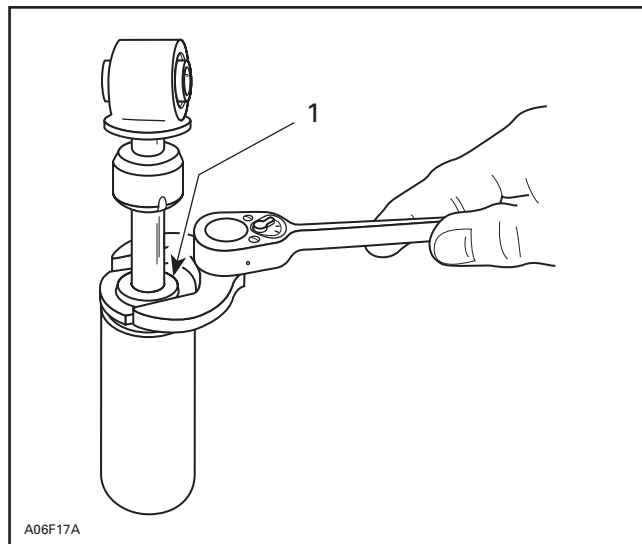

1. Torque seal carrier to 88-89 N•m (64-72 lbf•ft)

SECTION 03 - CHASSIS PREPARATION

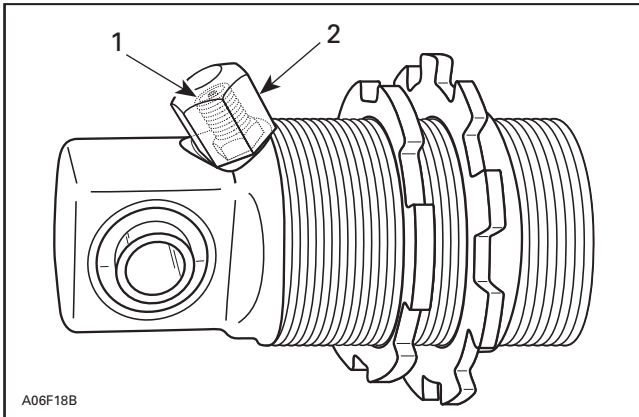

1. Schrader valve 1.5-2 N•m (13-17 lbf•in)
2. Schrader cap 5-6.5 N•m (44-57 lbf•in)

Adding Gas Pressure

Nitrogen (N_2) can now be added to damper body.

NOTE: Never substitute another gas for nitrogen. Nitrogen has been selected for its inert qualities and will not contaminate the gas chamber of the shock.

Preset your pressure regulator to 2070 kPa (300 PSI) nitrogen (N_2), this gas pressure will restore the correct pressure for your damper.

CAUTION: Do not exceed the recommended pressure values.

When removing and retightening the Schrader valve acorn nut use minimal torque. When the cap is over tightened and subsequently removed it may prematurely break the seal of the Schrader valve to the shock body and cause a loss of nitrogen charge without being noticed. If you suspect this has happened then recharge the shock as a precaution. Inspect the acorn cap before installation to ensure that the internal rubber gasket is in its proper position.

⚠ WARNING

Whenever working with high pressure gas, use eye wear protection. Never direct gas pressure toward anybody.

NOTE: Carefully inspect damper for gas or oil leaks. Any leaks must be corrected before continuing.

Damper gas pressure cannot be confirmed by using a pressure gauge. The volume of gas in the shock is very small, and the amount lost during gauge installation will lower the pressure too much and require refilling.

After recharging is complete and before installing the spring the rebuilt shock should be bench-tested. Stroke the shock to ensure full travel and smooth compression and rebound action. If the shaft moves in or out erratically this could indicate too much air is trapped inside. If the shaft will not move or has partial travel then it may be hydraulically locked. In either event the shock must be rebuilt again. Pay particular attention to the placement of the IFP, quantity of oil and shim stack/piston assembly.

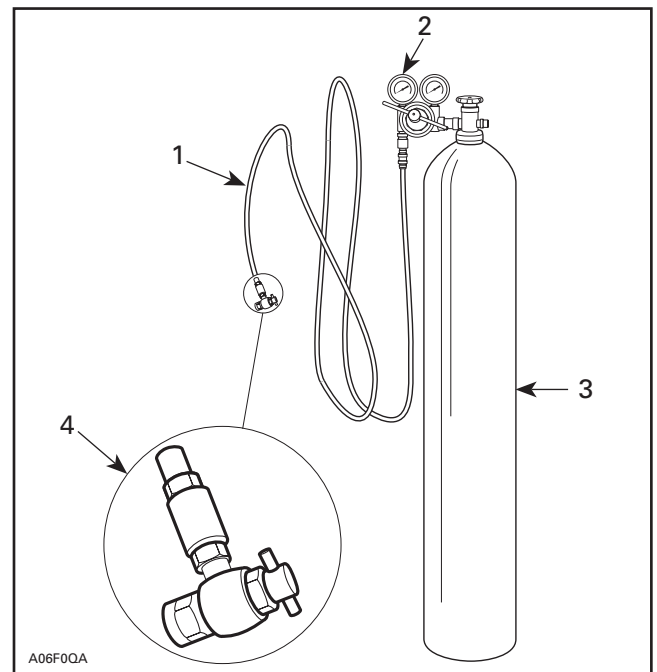

1. Automotive type air pressure hose
2. 2 stage regulator, delivery pressure range 2070 kPa (300 PSI)
3. High pressure cylinder filled with industrial grade nitrogen
4. Valve tip (P/N 529 035 570)

Reinstall damper spring retainer, then your spring. Next, thread the spring pre-load rings up to the spring. Set pre-load according to recommended spring length specifications. Your damper is now ready for reinstallation to your snowmobile.

SECTION 03 - CHASSIS PREPARATION

INTERNAL FLOATING PISTON MEASUREMENT

SHOCK P/N	MEASUREMENT mm
505 070 903	44.5
505 070 904	44.5
505 070 937	44.5
505 070 938	44.5
503 190 016	128
503 190 247	128
503 190 289	130
503 190 008	132
503 190 019	132
503 190 201	132
503 190 015	134
503 190 017	134
503 190 226	134
505 070 753	176
503 190 007	185
503 190 205	185
503 190 290	185
505 070 966	186
505 071 111	186
503 190 020	187
503 190 024	187
503 190 013	188
503 190 248	188

NOTE: If the floating piston is installed too far into the damper body, light air pressure through valve (with the core removed) will move the piston outward.

2003 MX Zx 440 HPG C-36 Shock Part List

P/N	DESCRIPTION
505 070 953	Shock ass'y left front
505 070 952	Shock ass'y right front
503 189 972	Shock ass'y center
503 189 974	Shock ass'y rear
486 130 026	Stop ring (spring protector) right & left
486 130 027	Collar (spring protector) right & left
486 130 028	Rubber bush (top eye)
486 130 029	Valve ass'y (base valve adjusters)
486 130 030	Bearing comp (seal head)
486 130 031	Label
486 130 032	Nut (hose)
486 130 033	O-ring (hose)
486 130 034	Packing (brass washer hose)
486 130 035	Bolt (hose)
486 130 036	Hose comp right & left
486 130 037	Hose comp center
486 130 038	Hose comp rear
486 130 039	Guide spring (abutment)
486 130 040	O-ring (remote cover)
486 130 041	Stop ring (remote cover)
486 130 042	Guide (remote cover)
486 130 043	O-ring (air valve)
486 130 044	Screw (air valve)
486 130 045	Air valve comp
486 130 046	Piston ring (floating)
486 130 047	O-ring (floating)
486 130 048	Free piston
486 130 049	Tank comp (remote) right & left
486 130 050	Tank comp (remote) center
486 130 051	Tank comp (remote) rear
486 130 052	Cylinder comp right & left
486 130 053	Cylinder comp center
486 130 054	Cylinder comp rear
486 130 055	Piston rod sub ass'y right & left
486 130 056	Piston rod sub ass'y center
486 130 057	Piston rod sub ass'y rear

C-36 HPG shocks use the same valve shims as other model HPG shocks except C-46

2003 MX Zx 440 HPG C-36 SHOCKS

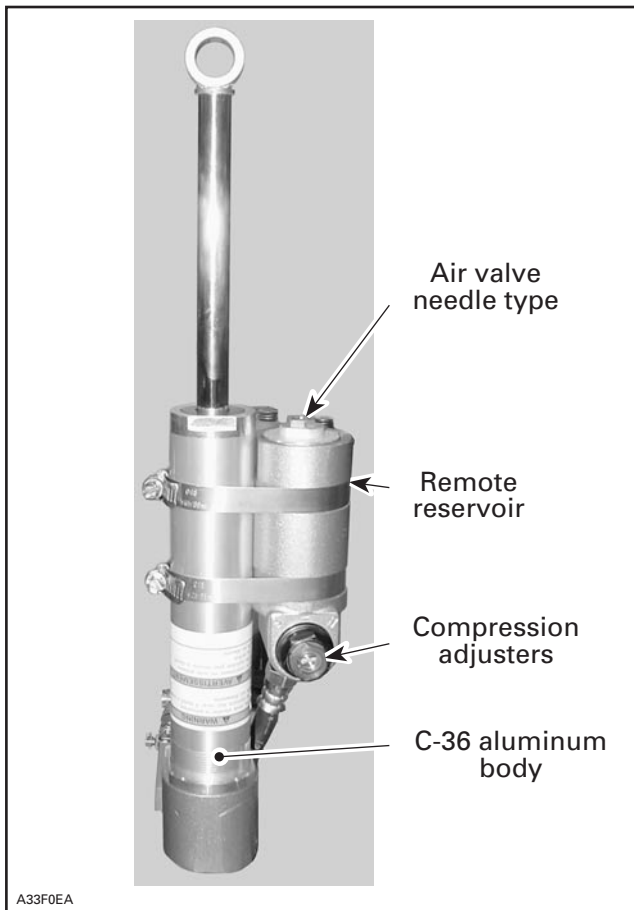

The 2003 MX Zx 440 REV will come equipped with four C-36 HPG shocks. Each shock will be equipped with high and low speed adjustable compression dampening (rear shock pictured).

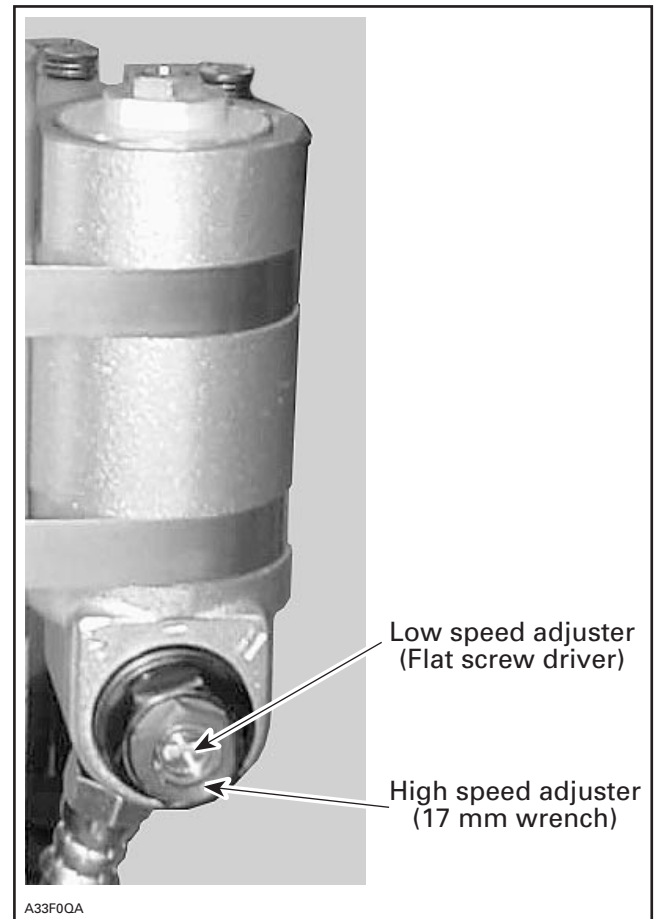

Low speed compression adjuster

The low speed adjustment is used to change the dampening force for relatively slow suspension movement. It is used to tune the vehicle for braking, cornering, holeshots and all the bumps that create low speed movement in the suspension. The low speed adjuster has 4 turns of adjustment. Turning the adjuster clockwise increases the dampening.

High speed compression adjuster

The high speed adjustment is used to change the dampening force for fast suspension. It is used to tune the vehicle for large, high speed jumps and bumps that create high speed movement in the suspension. The high speed adjuster has three turns of adjustment. Turning the adjuster clockwise increases the dampening.

SECTION 03 - CHASSIS PREPARATION

SHOCK REBUILD PROCEDURE

1. Tightly secure the shock base in vise. **DO NOT CLAMP ONTO SHOCK BODY.**
2. Using a 12 mm wrench, slowly remove air valve, allowing the gas inside the reservoir to escape.
3. Remove top seal cap using a 36 mm wrench. Pull shaft/valve stack assembly out of main shock body.

5. Push down the remote reservoir cover, remove the retaining clip.



6. Remove the remote reservoir cover.

4. Dispose of used oil properly.



SECTION 03 - CHASSIS PREPARATION

7. Remove the floating piston inside the remote reservoir.



8. Remove lock nut using a 14 mm wrench securing valve stack and piston to shaft.

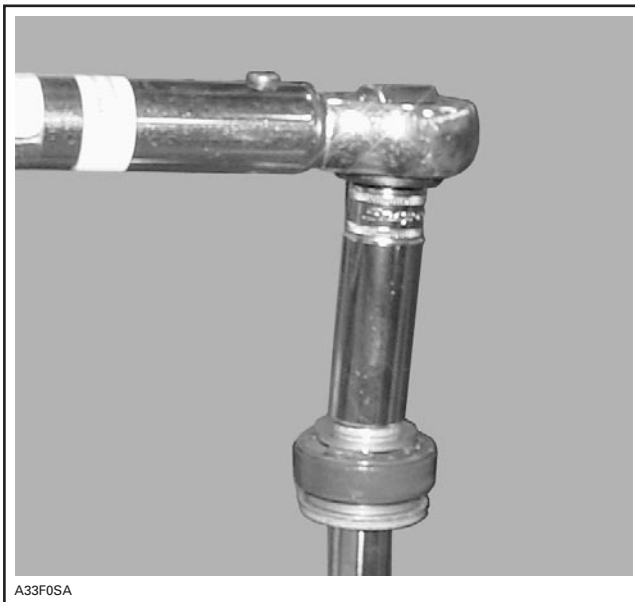

9. Carefully remove and layout shims, washers, and piston from shaft. Pay close attention to shim sequence and piston position.

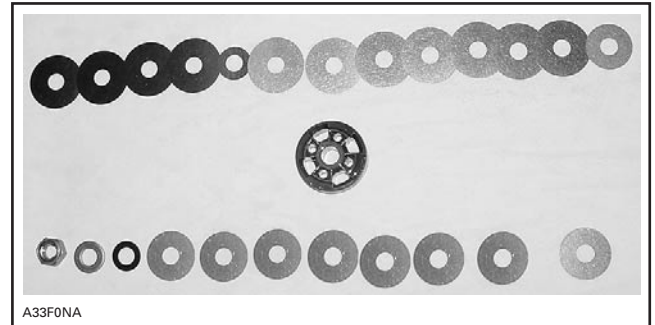

10. Clean all shock components using Bombardier Sheave Cleaner. **DO NOT MIX SHIMS AND WASHERS TOGETHER.**
11. Assemble valve shims, washers, and piston in proper order and place them back onto shock shaft.
12. Torque the rod nut at 11-13 N•m (97-115 lbf •in).

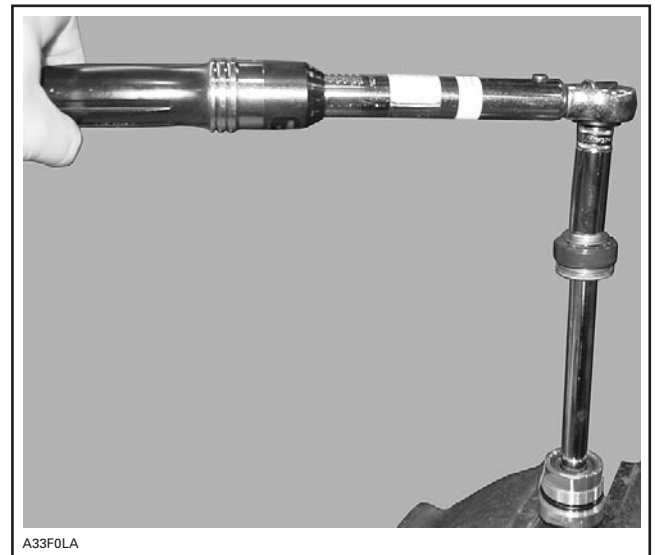

13. Fill main shock body with shock oil (P/N 413 711 806) to a level of half full.
14. Fill remote reservoir with Bombardier shock oil to within 6.4 mm (1/4 inch) from the top.
15. Hold the remote reservoir as to have the oil level in it at the same height of the oil level in the shock.

SECTION 03 - CHASSIS PREPARATION

16. Cup your hand and place it over the remote reservoir. Pump with your hand to circulate oil through the base valve (adjustment system) to remove any trapped air. Low speed adjuster must be open 1 turn minimum.
17. Fill the remote reservoir with oil. Lubricate O-ring seal on floating piston with shock oil and install. The key to good shock performance is to remove all the air from shock body, reservoir, and valve stack.



18. Push the floating piston to the bottom of the remote reservoir. Oil will rise in the main shock body almost to the top.
19. Fill the shock body with oil until level with bottom of threads.
20. Lubricate seal around piston and valve stack and gently push into main shock body.
21. Stroke the piston and valve stack slowly to remove any trapped air. Using a small hammer or wrench, gently tap on the shaft mounting eyelet to help remove air.

22. Again, push the floating piston to the bottom of the remote reservoir.
23. Pull the shock shaft as far out as possible and replace the seal cover and torque to 90-100 N•m (66-74 lbf•ft). Oil must spill from the shock body before the seal cover O-ring seals the shock.
24. Install the remote reservoir cover. Install the retaining clip. Pull cover to seat against the retaining clip. Make sure the cover is firmly seated against the retaining clip before filling with gas.
25. Install air inlet valve.
26. Pressurize the shock at 2068 kPa (300 PSI) with nitrogen. Use the correct needle tool (P/N 529 035 614).



27. Install the safety screw into the air inlet valve and clean your shock with Bombardier Sheave Cleaner.

SECTION 03 - CHASSIS PREPARATION

SHOCK VALVING

Front

Compression	7 x 30 x 0.152
	1 x 19 x 0.152
	3 x 30 x 0.203
	3 x 13 x 0.114
	1 slit piston 2 x 0.3
Rebound	3 x 26 x 0.254
	1 x 13 x 0.203

Center

Compression	5 x 30 x 0.203
	1 x 21 x 0.114
	4 x 30 x 0.254
	2 x 22 x 0.152
	1 slit piston 2 x 0.3
Rebound	1 x 26 x 0.254
	1 x 16 x 0.114
	7 x 26 x 0.254
	1 x 16 x 0.114

Rear

Compression	4 x 30 x 0.152
	1 x 18 x 0.114
	7 x 30 x 0.254
	1 x 24 x 0.254
	1 slit piston 2 x 0.3
Rebound	2 x 26 x 0.254
	1 x 16 x 0.114
	6 x 26 x 0.254
	1 x 16 x 0.114

C-36 HPG

SHIMS

P/N	SIZE (mm)	MOQ (minimum order quantity)
415 039 100	30 x .254	5
414 888 318	30 x .203	15
414 888 319	30 x .152	1
414 888 320	28 x .203	5
414 888 321	28 x .152	5
415 039 000	26 x .254	5
414 888 322	26 x .203	5
414 888 323	26 x .152	50
414 888 324	22 x .203	5
414 888 325	22 x .152	5
414 888 326	20 x .203	5
414 888 327	20 x .152	5
414 888 328	20 x .144	5
414 888 329	18 x .203	5
414 888 330	18 x .152	5
414 888 331	16 x .254	10
414 888 332	16 x .203	10
414 888 333	16 x .152	10
415 038 900	16 x .114	10
414 888 334	15 x .254	10
414 888 335	15 x .203	10
414 888 336	15 x .152	10
414 888 337	15 x .114	10
414 888 338	12 x .203	10
414 888 339	12 x .152	10
415 038 800	12 x .114	10
414 888 340	21 x .114	10
414 888 341	24 x .114	10

PISTONS

P/N	SIZE	MOQ (minimum order quantity)
414 888 304	0 slit	1
414 888 305	2 slits	2
414 888 306	4 slits	1
414 888 307	6 slits	1
	1 slit	

SECTION 03 - CHASSIS PREPARATION

C-46

REAR SHOCK SHIMS

P/N	SIZE (mm)	MOQ (minimum order quantity)
503 189 011	22 x .114	5
503 189 012	22 x .152	5
503 189 013	22 x .203	5
503 189 014	22 x .254	5
503 189 015	22 x .305	5
503 189 016	24 x .114	5
503 189 017	24 x .152	5
503 189 018	24 x .203	5
503 189 019	24 x .254	5
503 189 020	24 x .305	5
503 189 021	26 x .114	5
503 189 022	26 x .152	5
503 189 023	26 x .203	5
503 189 024	26 x .254	5
503 189 025	26 x .305	5
503 189 026	28 x .114	5
503 189 027	28 x .152	5
503 189 028	28 x .203	5
503 189 029	28 x .254	5
503 189 030	28 x .305	5
503 189 031	30 x .114	5
503 189 032	30 x .152	5
503 189 033	30 x .203	5
503 189 034	30 x .254	5
503 189 035	30 x .305	5
503 189 036	36 x .152	5
503 189 037	36 x .203	5
503 189 038	36 x .254	5
503 189 039	40 x 114	5
503 189 040	40 x 203	5
503 189 041	40 x 254	5

PISTONS

P/N	SIZE	MOQ (minimum order quantity)
503 189 004	0.0	1
503 189 003	1.2	1
503 189 002	1.7	1
503 189 001	2.0	1

SECTION 03 - CHASSIS PREPARATION

CHASSIS SET-UP

General

Reducing rolling resistance of a snowmobile is also an important area to explore when you are searching for the ultimate top speed. The horsepower required to overcome rolling resistance or drag increases approximately with the square of velocity so small reductions here can provide measurable improvements in top speed.

Good chassis set up starts with accurate alignment of the drive axle, countershaft, suspension system, and chassis. Use the following procedure to check your vehicle:

Remove the rear suspension, driven clutch, tuned pipe and muffler, track and drive axle. Check to see that the spacing of the drive sprockets is correct on the drive axle. The sprockets should be centered in the space between the rows of internal drive lugs on the track.

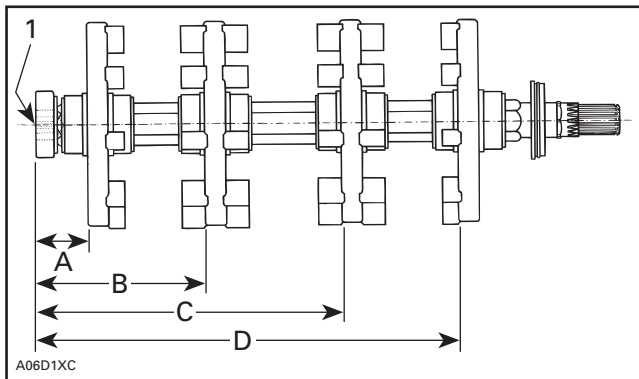

1. Measure from end of drive axle
- A. 47.3 mm (1.862 in)
 - B. 149.8 mm (5.898 in)
 - C. 272.8 mm (10.740 in)
 - D. 375.3 mm (14.776 in)

Use a press or special tool (P/N 861 725 700) for shifting the sprockets. The sprocket indexing should also be checked. The maximum desynchronization is 1/16 inch (1.5 mm). The drive axle can be chucked in a lathe and spun to observe the sprocket "wobble" and run out. Wobble should not exceed 2 mm (.080 in). While this amount of wobble may look excessive, it does not affect performance. If wobble is more than allowed, the sprockets should be replaced.

Maximum run out should not exceed 0.5 mm (.020 in). A maximum of 1 mm (.040 in) can be removed from the sprockets to true the diameter.

CAUTION: Do not remove more than 1 mm (.040 in) of material or the sprockets will start to go out of pitch with the track.

Reinstall the drive axle leaving the left end bearing housing off.

Loosen the left side countershaft eccentric bearing collar and slide the bearing retainer out so that the shaft end is free to locate itself in the support opening.

With both left shaft ends free, you can see if the shafts are centered in their bearing mount holes.

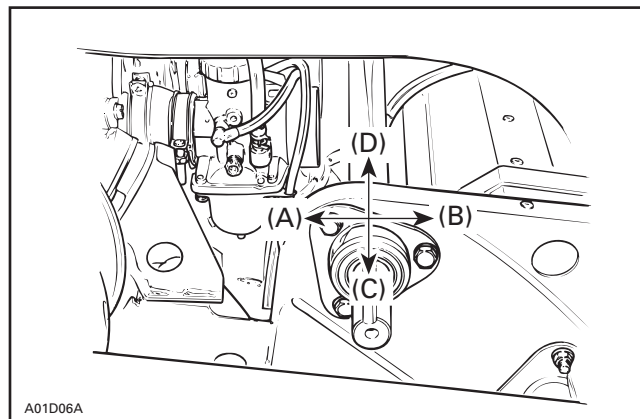

TYPICAL

NOTE: Shafts will have a tolerance in the bearing housings and the bearings themselves. These tolerances can be felt by hand. The shafts should be mid-point in these tolerances when centered in the bearing mount holes. If not perfectly centered, the two upper chaincase bolts should be loosened and shims should be added between the chassis and chaincase as necessary to align the countershaft and drive axle in their bearing mount holes. Depending on the amount of shims added, it may be necessary to use longer chaincase bolts. Make certain the bolt is fully engaged in the nut when properly torqued.

Now, reinstall the left end bearing housing. Using a large carpenter's square, check to see that the drive axle is square (90°) with the tunnel. If not, slot the left end bearing housing holes and reshim the chaincase to square up the drive axle and the countershaft.

SECTION 03 - CHASSIS PREPARATION

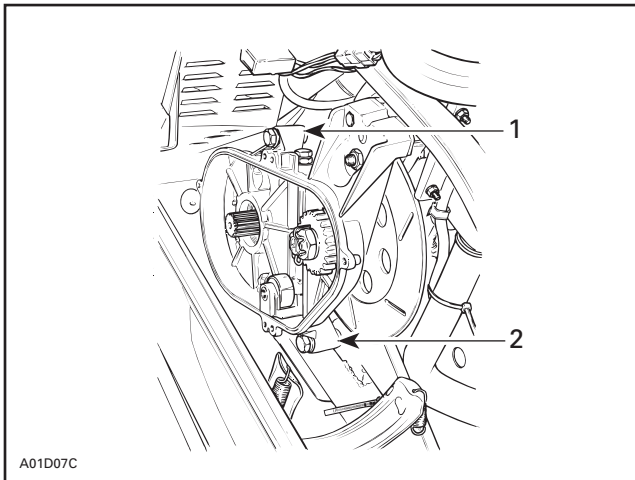

TYPICAL

1. Shim location
2. Shim location

Reinstall the rear suspension and using a square check to see that the runners are square (90°) with the drive axle. If not, cut and shim the ends of the suspension cross tubes to perfectly align the runners and also remove any side-to-side movement. If the suspension must be shimmed, correlate the adjustment with the next step.

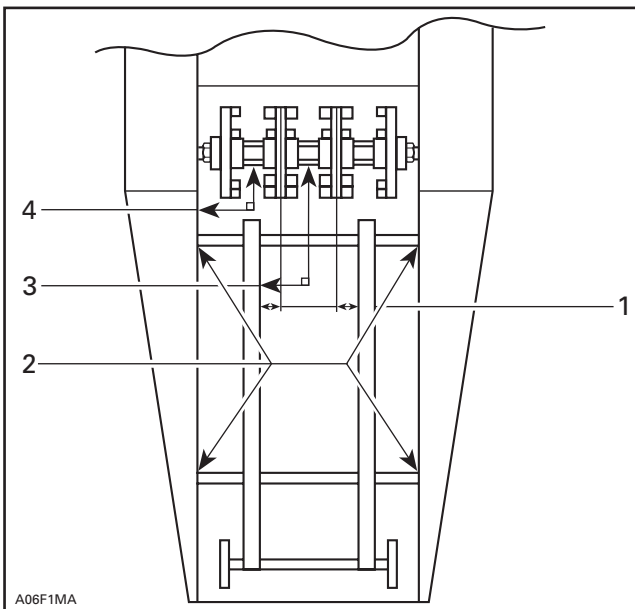

1. Align runners with drive sprockets. Equal distance both sides.
Shim drive axle to reduce end play
Maximum end play = .060" (ideal = less than .030")
2. Cut ends of tubes and shim as required to align suspension and remove freeplay
3. Suspension square with drive axle
4. Drive axle square with tunnel

Now check the axial play (side-to-side clearance) of the drive axle. The axle must not move more than 1.5 mm (.060 in) from side to side. Ideally, the axle has 0.25 – 0.50 mm (.010 – .020 in).

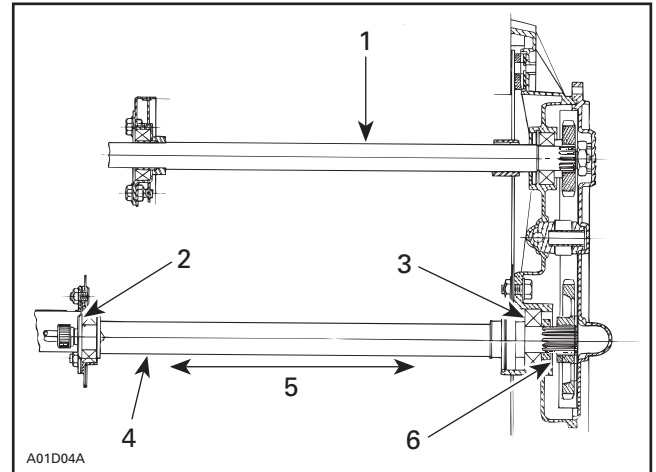

TOP VIEW

1. Countershaft
2. Shim position on end bearing housing side
3. Shim position on chaincase side
4. Drive axle
5. Axial play
6. Shim between sprocket and spacer

If the axle must be shifted left or right, note the direction and distance, and shim the axle as necessary.

Shims can be placed between the left side bearing and the end bearing housing to move the axle to the right or between the right side bearing and the chaincase to move the axle to the left.

NOTE: If shims are placed between the chaincase and the right side bearing, an equal thickness shim must be placed between the drive chain sprocket and the spacer on the axle.

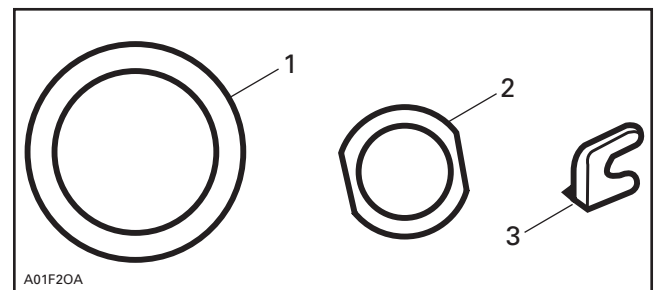

1. (P/N 501 020 500)
Shim, drive axle end bearing housing 1.6 mm (.063 in) thick
2. (P/N 506 041 400)
Shim, drive axle chaincase side 1.6 mm (.063 in) thick
3. (P/N 504 039 800)
Shim, chaincase perpendicularity 0.5 mm (.020 in) thick

SECTION 03 - CHASSIS PREPARATION

Rear Axle Modification

Heavily studded tracks combined with hard cornering put enormous loads on the track. To reduce the chance of derailing the track and to help spread the tensile loads of the track, a fourth idler wheel should be installed.

The two inner idlers should be placed so that they run between the left and right double rows of drive lugs. This will help maintain alignment of the track and lessen the chance of derailing.

Use the spacing shown in the drawing noting that the outer two idler wheels are in their original position.

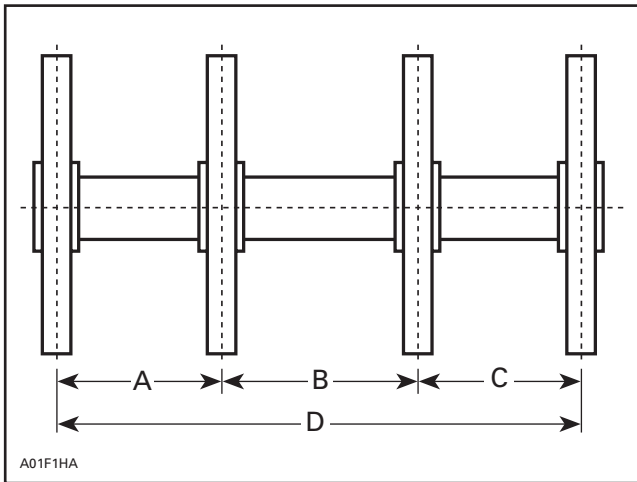

- A. 101.5 mm (3-63/64 in)
 B. 123 mm (4-27/32 in)
 C. 101.5 mm (3-63/64 in)
 D. 326 mm (12.83 in)

When you have reinstalled the track and suspension, make certain that all bolts attaching the suspension to the chassis are installed with high strength threadlocker (Loctite 271), and that bolts are properly torqued.

There are grease fittings on all moving parts of the suspension and they should be greased on a weekly basis with a quality, low temperature grease (P/N 413 711 500).

Finally, adjust the track tension and alignment. Track tension and alignment are most critical to top speed. Make certain the track is aligned so that you have equal clearance between the slider shoe and the track guides on each side of the snowmobile.

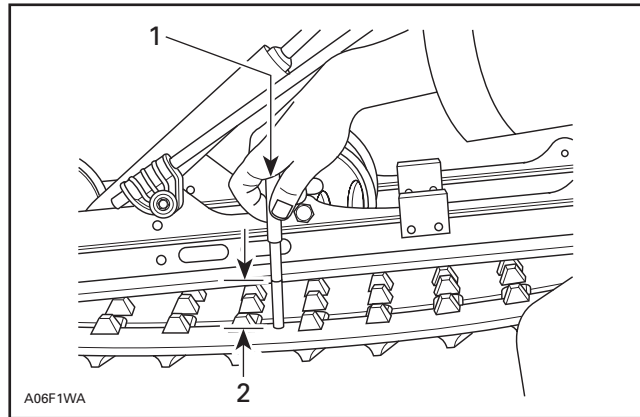

TYPICAL

1. 7.3 kg (16 lb)
 2. Deflection

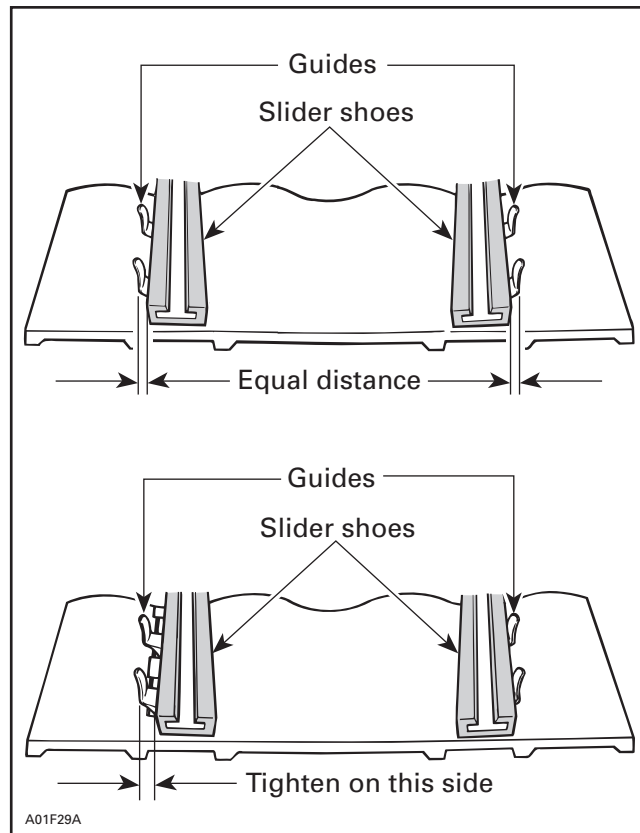

For straight line racing, top speed can sometimes be increased by running the track a bit looser. Ratcheting of the drive sprockets during hard acceleration can occur if the track is too loose. Conversely, heavily studded tracks may need to be tighter to achieve top speed because the extra weight of the studs may cause the track to **balloon out** at high speeds.

NOTE: Track tension should be checked whenever major changes are made to the limiter strap length and/or ride height changes.

BRAKES

To achieve maximum top speed and proper brake functioning, it is important to make sure the brake disc is loose on the countershaft to allow the disc to float and remain centered between the brake pads. The shaft should be lubed to maintain the floating disc.

If extreme brake use is anticipated, use 3 inch diameter dryer hose (or equivalent) to route outside air directly from the hood vents to the brake area.

SKI-DOO hydraulic brake systems use DOT 4 brake fluid. For conditions where extreme brake heat is generated, DOT 5 fluid can be used. DOT 5 has a higher boiling point but it is more susceptible to moisture intrusion and should be changed on a regular basis. DOT 5 should not be used for long, multi-day cross country racing where maintenance is minimal.

If the brakes become **spongy**, the system should be bled to remove any air bubbles. If the brake fluid is dark and/or cloudy, flush the complete system and refill with fresh brake fluid.

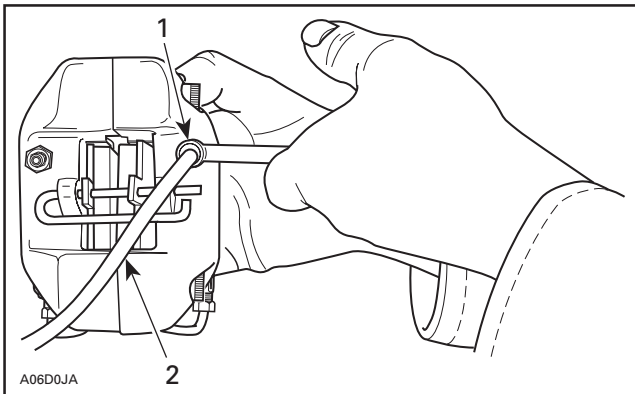

1. Hold bleeder adaptor while opening bleeder
2. Clear hose to catch used brake fluid

Pump a few times brake lever and while holding brake lever depressed, open bleeder and check for air to escape.

Repeat with the same bleeder until no air appears in hose.

Proceed the same way with the right side bleeder.

When refilling the injection oil container be careful not to overfill as excess oil can drop onto the brake disc and impregnate the brake pads. If this happens the brake pads should be replaced to ensure maximum braking performance.

AERODYNAMIC CONSIDERATIONS

Yes, aerodynamics are an important consideration in snowmobile design. The horsepower required to overcome aerodynamic drag increases according to the cube of the velocity. At speeds under 64 km/h (40 MPH), the aerodynamic considerations are not great, but when you approach the 160 km/h (100 MPH) mark, simply how you sit on the snowmobile can mean 6.4 km/h (4 MPH) in top speed.

Bombardier has spent many hours in the wind tunnel on the hood design, and has optimized the shape to fit the function. You cannot improve the shape of your snowmobile but you can reduce the frontal area of the snowmobile by lowering the ride height and by using the lowest windshield available.

The high windshield offers the rider good wind protection. That protection, however, translates into increased frontal area and more aerodynamic drag. If you are running at a local radar run with the high windshield on, you should sit upright behind the windshield. Crouching behind the windshield increases drag because of interruption of the air flow from the top of the windshield to the rider's back.

When the low windshield is fitted, the opposite is true, you should crouch behind the low windshield for best top speeds. When crouched behind the low windshield, there is an improvement in the aerodynamics compared to sitting upright behind the high windshield. That translates into an increase at top speed in a laboratory setting.

Because of the purity of the air flow in the wind tunnel, you should not expect this increase in normal running, but you can always expect a 3.2 – 4.8 km/h (2-3 MPH) improvement and even more when winds are still.

Lowering the vehicle a couple of inches can also improve top speed by 1-3 MPH.

SECTION 03 - CHASSIS PREPARATION

ADJUSTING RIDE HEIGHT

A cross-country racer will want all the suspension travel you can for a rough snowcross-type event. But when racing a high speed event on a relatively smooth lake, giving up some of the suspension travel to lower the machine is advantageous. Lowering the machine, reducing the ride height, does 3 things for you:

1. Lowers the center of gravity of the machine; which improves cornering.
2. Reduces the frontal area of the sled; which improves aerodynamics.
3. Reduces the approach angle of the track; which reduces drag.

A person wanting to lower the machine for a short event like a radar run may simply chain or strap the machine down. Provided the course is quite smooth, this can work, but realize that strapping down the suspension preloads the springs highly and the ride will be very stiff. This technique is not recommended for most forms of racing.

The most common technique for lowering the machine is to use shorter springs or to shorten the existing springs by heating and collapsing a coil or 2 of the spring as needed. Realize that shortened springs will have very little preload when the suspension is in its "topped out" position, and it may be necessary to safety wire the spring collars into position, and use additional limiter devices like straps, chains or on HPG /A shocks, a spacer can be added internally to limit the extension of the shock.

NOTE: Some race organizations do not allow shortening springs so a proper optional short spring would be used.

Lowering the Front Suspension

Make limiter straps from standard rubber limiter strap material or link chain and go from shock bolt to shock bolt (longer shock bolts will be required). The length of the strap should be adjusted to obtain the desired ride height. Most rules require you to maintain 2 inches of suspension travel.

Shorter springs should be used to avoid excessive preload.

On vehicles with rebuildable shocks (HPG T/A), a spacer can be installed internally on the shock shaft to limit the shock extension. Spacers can be fabricated from 1 in O.D. aluminum round stock. (Refer to the shock rebuilding section for proper installation procedures).

The threaded adjusters can be loosened to provide the desired amount of spring preload.

Lowering the Rear Suspension

Option 1: The rear suspension can be lowered by compressing the rear scissors to the desired ride height and installing a strap to maintain this height. Compressing the rear scissors adds a great deal of preload to the rear torsion springs. Use softer springs.

Option 2: It is also possible to lower the rear suspension on vehicles equipped with HPG T/A shocks, by using a spacer to limit shock extension.

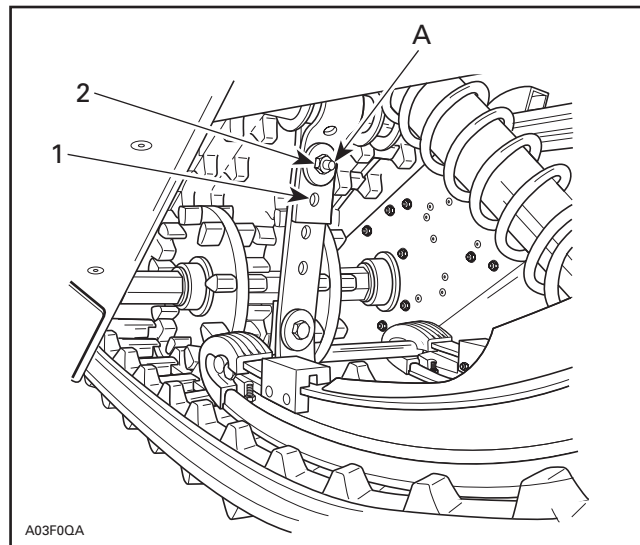

1. 1st hole
2. 2nd hole
- A. 11 N•m (97 lbf•in)

Center

Shorten the limiter strap(s) to match the ride height of the front and rear and obtain the desired amount of weight transfer. New holes can be punched in rubber limiter straps. A shorter nylon limiter strap (P/N 414 955 300) is available for the vehicles with the strap and bolt style.

On vehicles with HPG T/A shocks the threaded adjusters can be loosened to reduce the amount of spring preload. If less preload is desired or on vehicles with cam adjusters, shorter springs may be used to reduce excessive spring preload.

TRACK GUIDES

Additional taller track guides (P/N 486 078 200) should be installed when oval racing with a heavily studded track. These taller guides help prevent derailing without having to overly tighten the track. When in a turn, the side loads on the guides are extremely high and it is advantageous to reduce the load per guide by adding more of the guides.

All of the flat cleats should be removed from the right side of the track and replaced with guide cleats. (See drawing).

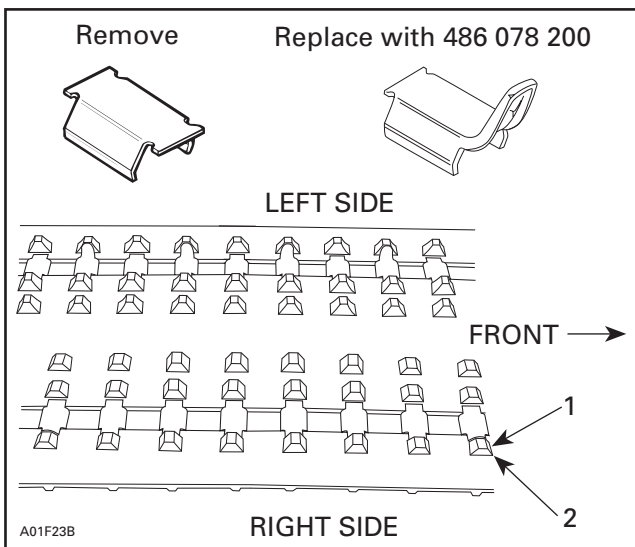

- 1. Standard
- 2. (P/N 486 078 200)

NOTE: When installing taller track guides or studs part (P/N 572 086 100), bushings should be installed inside the rear torsion springs on rear suspensions. Track guide clearance should also be checked on top of the rear suspension A.C.M.

For ice lemans type racing where left and right hand corners are encountered, extra guides should also be installed on the left side of the track.

There are two special tools which greatly enhance the removal and addition of guide clips.

(P/N 529 028 700) Guide clip remover.

(P/N 529 008 500) Guide clip crimper.

TRACK STUDDING

⚠ WARNING

Installation of track studs is a modification not recommended. This modification may affect amongst others stopping distances and track strength. Studs may also be projected, thereby causing personal injuries to operator and/or bystanders. Bombardier disclaims liability for all damages and/or injuries resulting from use of the studs. Modifications of any Bombardier-made snowmobile voids the vehicle warranty and that such modifications may render use of the vehicle illegal in other than sanctioned racing events under existing federal, provincial and state regulations.

Traction control requires the installation of studs to the track so that you may improve the acceleration, direction and braking of the snowmobile on certain surfaces. Selection of the proper traction components is very important. It is also important to have the proper number of studs and to keep them sharp or replaced at all times.

For racing on hard ice, the single point stud is the most popular. If the ice gets a little softer, racers will add a variety of stamped studs. Always use Loctite when installing your studs.

Stud sharpness counts more than the number of studs. Fewer sharp, fresh studs work much better than a great many dull studs with a few new ones thrown in. Too many studs will keep the points from digging in and the sled will float, instead of hooking up.

If the studs do not prick your finger when you touch the tip they are not sharp enough. A small die grinder can be used to sharpen worn studs.

Place studs where pressure is concentrated on the edge of the track for turns, in the center of the track for acceleration and braking.

Hooker plates are welded to the track cleats and place the studs directly beneath the slider shoes for maximum pressure. The hooker setup is very hard on tracks, particularly the fiberglass reinforcing rods.

The other thing that must be kept in mind if hooker plates are used is that the studs will be directly in line with the heat exchanger protectors. The protectors must be removed and another system employed to protect the heat exchangers.

SECTION 03 - CHASSIS PREPARATION

Depending upon machine setup, driver weight and driving characteristics, 250 to 300 penetrator studs will be required. The 121 inch track has 48 pitches. The most studs that can effectively be placed on each pitch is 7 — which means the maximum number of studs the track can hold is 336.

The drawing below shows a pattern of 6 studs alternating with 7 studs for a total of 312 studs. Try to keep studs from following the same line for 3 pitches.

NOTE: Refer to the appropriate section of this book for specific stud patterns for various types of racing.

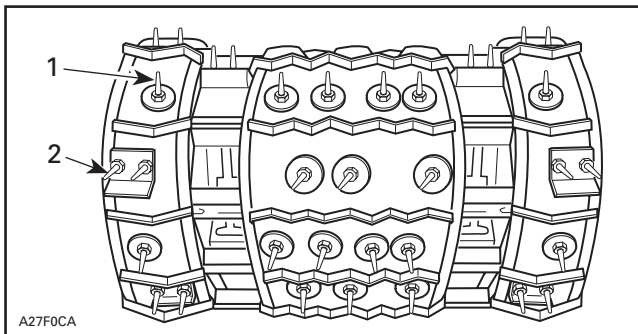

TYPICAL

1. 6 stud row
2. 7 stud row

Most race associations sanctioning oval, snow cross and cross-country events limit the length of the studs to 3/8 inch above the high point of the track, while most drag and speed run associations allow a 3/4 inch limit. Rules do vary, however, and it is your responsibility to make certain your studs are legal. It is also necessary to protect the heat exchangers from damage from the studs.

CAUTION: Check condition of heat exchanger after every race.

Take the time and care to lay out your stud pattern carefully. And, make sure you write down what works best for you at certain tracks and various conditions.

NOTE: The track must be run in for ten (10) hours before holes are drilled to receive the studs. This must be done to stretch out all the elements of the track before any of the track cords are cut by the studding operation.

SKIS AND RUNNERS

The skis on your Ski-Doo are not flat on their bottoms, they are slightly convex. This is done to improve stability at high speed on straightaways.

The plastic ski on the MX Zx and MX Z incorporates more of its use (rocker effect). This plastic ski will work very well on snowy surfaces as it increases flotation and reduces drag. For oval and Ice Lemans, the new profile is superior to the steel ski.

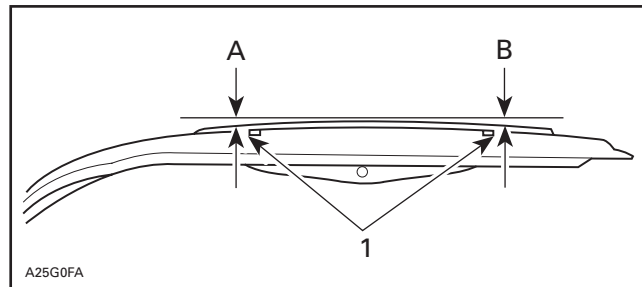

1. The above illustration is an example of what is called rocker
- A. 2 mm (3/32 in)
- B. 2 mm (3/32 in)

Check your skis from time to time to confirm the 2 mm (3/32 in) (measured at the ski runner studs) bow. If the skis have flattened, use a hydraulic press as necessary to restore the original shape. This is most important for oval racers.

Plastic skis or liners are good for a 2 MPH increase in speed in most snow conditions, more in sticky snow conditions.

Carbide inserted ski runners are necessary for all forms of racing except drag racing and radar runs. The type of racing you are involved in and the condition of the track will determine what style of carbide and how much carbide you will be using.

For the ice race track, special flat-backed race runners with 60° carbide inserts are a must. The flat back of the runner helps to keep the runner from being rolled over by cornering forces. The best racing runners are heat-treated to prevent them from bending under high side loads.

When installing carbide inserts, start with 100 mm (4 in) of carbide in front of a line projected from the center line of the ski leg and 125 mm (5 in) behind the line. Always keep the amount of carbide behind the line longer than in front.

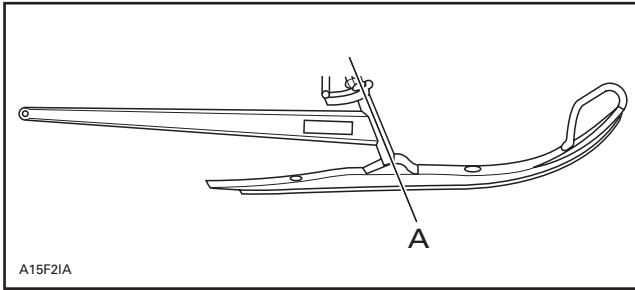

A. 122 mm (5 in) 98 mm (4 in)
 147 mm (6 in) 171 mm (7 in)

Once you have determined how much carbide you will be using, make up at least one more set. Sharp carbides dig! They must be sharp enough that when you drag your thumb nail over them, they will scrape off some of the nail. To keep your carbide runners in this condition, you must sharpen them every 5 or 6 laps. This is why you should have an extra set ready to go on in a hurry.

The condition of the skis and runners, as well as their alignment, has an effect on top speed. The ski toe-out must be correct; any irregularities in the skis should be removed, and bent or badly worn runners must be replaced.

Ski runners used for cross-country racing must be selected for the type of conditions you will be running in. When exposed earth or plowed roads are to be encountered in an event, full length carbide runners should be used. The concern here is to make the runner and the ski last through the event. These runners are usually set up with 245 mm (10 in) of 60° carbide in the center of the bar with the front and rear portions of the bar filled in with 120° carbide inserts.

When the event is held on a lake or surface conditions consist only of snow and ice, a flat-backer runner with 150 to 200 mm (6 to 10 in) of carbide will do the job. Remember, the more carbide you install, the more positively the front end steers, but more steering effort is also required. Cross-country events run for many hours not just a few minutes like an oval event. Match your carbide to the strength and endurance of your arms.

A cross-country carbide does not need to be razor sharp. In fact, testing should be done with a slightly dulled edge, that way your set-up will be right for the majority of the race. If you test with sharp carbides, your chassis set-up will be off when the runners lose their edge after 5-10 miles.

CAUTION: The amount of carbide allowed on each runner may be limited by your race association. Check your rule book.

BUMP STEER

Bump steer refers to the amount of change in the toe-out of the skis as the suspension moves through its total vertical travel. Block up the machine so that the skis are just off the ground and remove the springs from the shocks. This will allow you to cycle the suspension and measure the bump steer on your vehicle.

You will need a reference point to measure to as you cycle the suspension through its travel. Because you will be lifting the ski and suspension assemblies as you are measuring, you should use a reference point that is not easily bumped out of position. A pair of concrete blocks set on a line about 50 mm (2 inches) away from the edge of the ski and parallel to the ski works nicely.

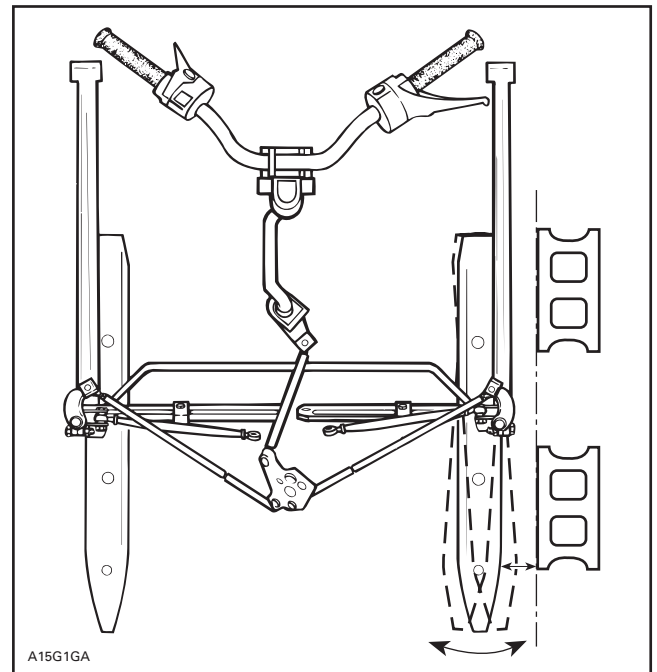

Lift the ski up to its upper travel limit. Using a measuring tape, measure the distances from the front and rear edges of the ski to the concrete block reference. The front and rear measurements must be equal or no more than 1.6 mm (1/16 in) difference if the bump steer adjustment is correct.

SECTION 03 - CHASSIS PREPARATION

SKI LEG CAMBER

The camber angle of the ski legs changes how aggressively the ski runners hook up with the driving surface. Adding negative camber will have the most effect on handling. This is because the weight shift in a turn is always to the outside of the turn and the negative camber of the ski leg causes the wear bar to be presented to the driving surface in a more aggressive position. Positive camber will tuck the wear bar in toward the sled, thereby reducing its traction in a turn.

Camber adjustments do have an effect on the width of the machine. Make certain your camber adjustments do not push you beyond the overall width limit imposed in most forms of racing.

Camber is the tilting of the ski leg from the vertical. To obtain a negative camber angle, the ski leg must be tilted inward so that the ski legs are closer together at the top than at the bottom. Positive camber would tilt the top of the ski leg away from the machine. Camber angle is measured in degrees from the vertical and must be noted as positive or negative.

Most oval racers set the left ski leg at 0° camber and the right at - 3° to - 5° camber. Trail riders and drag racers should set both ski legs at 0° camber while cross-country and snowcross riders most often set up both ski legs with - 1° to - 3° camber.

Camber angle is measured using an angle finder available from most tool supply stores.

Adjustment is performed by adjusting the length of the upper control arm.

2003 MX Zx 440 REV Front Suspension Settings

The ski springs rate is 18.39 N/mm (105 lbs/in) (P/N 505 071 201). The spring must be preloaded by 10 mm (3/8 in) at full extension. Attention, the front spring must always have a minimum preload of 3 mm (1/8 in) and a maximum preload of 25 mm (1 in). Always set the spring preload with a fully extended suspension. For a softer spring, the (P/N 486 130 023) 15.76 N/mm (90 lbs/in) will fit on the production shock. For a stiffer set-up, use (P/N 486 130 024) 21.01 N/mm (120 lbs/in).

The MX Zx 440 REV will come with a 12.7 mm (1/2 in) non adjustable anti-roll bar. At the time of printing this manual, no other options were available.

The front suspension have 251 mm (9.9 in) of travel, 4.94° negative camber at full extension, 2° negative camber fully compressed. The toe must be 3 mm (1/8 in) open, no bump steer, 13 mm (1/2 in) of scrub at the worst condition.

The ski leg comes with a pilot hole for ice racing purpose. (See picture below)

The side of the ski leg is machined at 2° angle. To measure your camber, add this 2° to your measure.

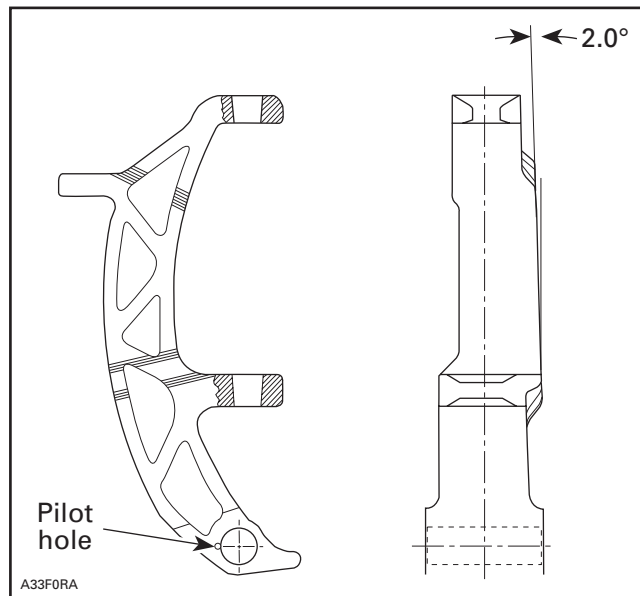

SKI TOE-OUT

Most oval racers use modified handlebars with loops or angles on the left end. Often a driver prefers a handlebar position that is not horizontal when the skis are in their straight ahead position. This allows a more comfortable driving position when in a corner. Whatever handlebar you prefer should be positioned as you prefer it when going down a straightaway before you begin your toe-out adjustment.

Use a rubber cord stretched between the ski tips to keep constant pressure on the steering system while measuring toe-out. Measure the distance between the inner edges of the skis as far back and as far forward on the skis as possible. Avoid measuring at a point at the top or heel of the ski where the ski is tapered. With aggressive race carbide, the measurements should be taken at the front and back of the runners on the cutting edge for the most precise measurement.

Skis must have a toe-out of 3 to 6 mm (1/8 to 1/4 in) when they are in the straight ahead position.

Adjustment is performed by loosening the lock nuts on the ball joints at the ends of the left and right tie rods. Rotate tie rods as necessary to achieve the proper toe-out and handlebar position. Do not use the short tie rod that runs beneath the engine to adjust ski toe-out.

Never lengthen a tie rod so that the threaded portion of the ball joint extends over 17 mm (11/16 in) beyond the tie rod. To avoid this, distribute the adjustment requirements equally to both left and right tie rods.

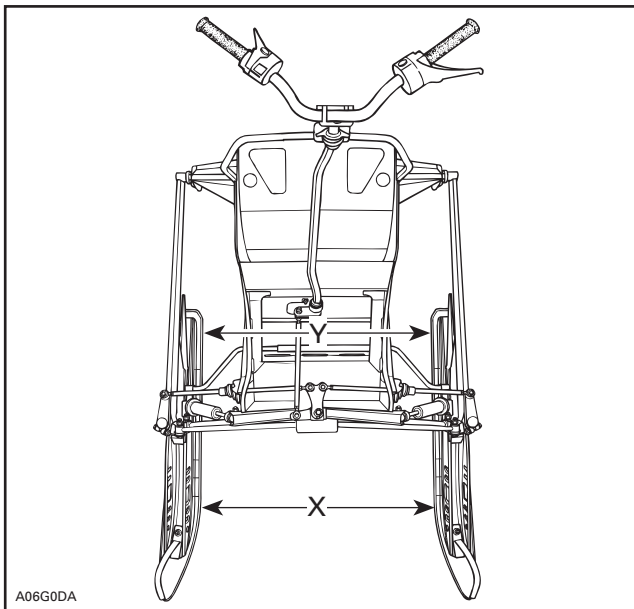

$$X = Y \pm 3 \text{ mm (1/8 in)}$$

Retorque ball joint lock nuts to 29 N•m (21 lbf•ft) when toe-out is correct.

With the aggressive setup of the front end necessary for competitive oval racing, it is important to keep all the steering system components tight and free of play. Worn ball joints and bushings should be replaced, bolts holding the skis to the ski leg must be tight and wear bars must be straight and bolted securely to the skis. Any play in the steering will result in severe chattering in the corners and darting on the straightaways.

CHASSIS TUNING GUIDELINES

How to Deal with Handling Problems

There is usually never one adjustment that will correct a certain handling quirk. You will usually end up with several changes in setup to achieve the same goal. There are certain basics to keep in mind, however, when you are working with your sled:

- Handling problems encountered when entering a corner are usually corrected by working with front end adjustments.
- Handling problems encountered when exiting a corner are usually corrected by working with rear suspension adjustments.
- Basic handling problems are often traced to improper suspension adjustments.

Guide to Handling Problems

NOTE: PUSHING refers to the front of a vehicle not steering as much as the driver wants. The skis are not grabbing the surface with sufficient force. LOOSE refers to the rear of a vehicle sliding outward in a turn. The track is not grabbing the surface with sufficient force.

NOTE: Center spring/shock refers to the front arm of the rear suspension.

1. Problems encountered when entering a corner.
 - a. Front end pushes coming into a corner (steering is not precise).
 - Sharpen carbide runners.
 - Add more carbide.
 - Shorten limiter strap on center arm.
 - Increase negative camber of ski legs.
 - Increase ski spring preload.
 - Decrease center spring preload.
 - b. Rear of machine starts to come around or is loose when entering a corner.
 - Lengthen limiter strap on center arm.
 - Decrease ski spring preload.
 - Decrease negative camber of ski legs.
 - Increase center spring preload.
 - Sharpen/add track studs.

SECTION 03 - CHASSIS PREPARATION

- c. Inside ski lifts.
 - Reduce the amount of negative camber on the ski legs.
 - Check for free operation of stabilizer bar.
 - Decrease preload of ski springs.
 - Shorten limiter strap on center arm.
- 2. Problems encountered while going around or exiting a corner.
 - a. Front end pushes coming out of corner (steering is not precise).
 - Shorten limiter strap on center arm.
 - Decrease center spring preload.
 - Check condition of carbides.
 - Add more carbide.
 - Increase negative camber of ski legs.
 - Increase ski spring preload.
 - Increase rear spring preload.
 - Tighten A.C.M.
 - Increase rear to front coupling.
 - b. Rear of machine starts to come around or is loose when exiting a corner.
 - Lengthen limiter strap on center arm.
 - Decrease ski spring preload.
 - Increase center spring preload.
 - Decrease negative camber of ski legs.
 - Decrease rear spring preload.
 - Loosen A.C.M.
 - Decrease rear to front coupling.
 - c. Left ski lifts.
 - Shorten limiter strap on center arm.
 - Decrease center spring preload.
 - Check for free operation of stabilizer bar.
 - Increase stabilizer bar diameter or shorten end levers.
- 3. General handling problems.
 - a. Machine darts from side to side on straight-away.
 - Check ski toe-out.
 - Check for loose ball joints in steering.
 - Too much negative ski leg camber.
 - b. Excess effort required to turn handlebars.
 - Check steering linkages for binding and/or corrosion.
 - Rubber blocks between skis and ski legs have too much preload at the rear (causing rear of skis to be pushed down too much).
 - Lengthen limiter strap on center arm.
 - Increase center spring preload.
 - Decrease ski spring preload.
 - Too much carbide on ski runners.
- 4. Adjusting the suspension for ride and comfort.
 - a. The rear springs of the rear suspension should be adjusted as follows:
 - Fully extend the rear suspension.
 - Measure from the floor to the bottom of the rear grab handle (remember this dimension).
 - Load the vehicle as it will be used (1 or 2 people, saddlebags full of equipment, etc.).
 - Again, measure from the floor to the bottom of the rear grab handle. This dimension should be 25 mm to 50 mm (1 in to 2 in) less than the fully extended dimension.
 - If the vehicle settles more than 50 mm (2 in), increase the rear spring preload.
 - If the vehicle settles less than 25 mm (1 in), decrease the rear spring preload.
 - This is a preliminary setting only! Increase and decrease the preload adjustments to fine tune for your preference.
 - The center spring and ski springs will have the most affect on handling, but if the preload is too stiff, it will produce a harsh ride.

General Tips

If the spring and preload combination you are using exerts the right amount of pressure at full compression but has too much force at initial compression, try a shorter, stiffer spring. The shorter spring will not be preloaded as much and will “act” softer during initial compression, but will get stiffer as the suspension compresses. Conversely, if a setup is good at initial compression but too stiff at full compression, then a softer spring would be used. The following chart can be used to determine how much force a spring and preload combination will exert during compression.

TABLE OF CONTENTS

ENGINE TUNING CAUTIONS	04-3
BASIC ENGINE THEORY	04-3
OPERATION OF THE RAVE VALVE	04-6
CARBURETION	04-9
MIKUNI VM AND TM TYPE CARBURETORS	04-13
TM 40 CARBURETORS	04-13
IGNITION SYSTEMS, SPARK PLUGS	04-28
493, 593, 693, AND 793 ENGINE TYPES	04-31
TOP END	04-33
MAINTENANCE	04-32
REMOVAL FROM VEHICLE	04-32
INSTALLATION ON VEHICLE	04-32
TROUBLESHOOTING	04-34
COMPONENT REMOVAL WITH THE ENGINE INSTALLED	04-34
CLEANING	04-34
DISASSEMBLY	04-34
INSPECTION	04-36
ASSEMBLY	04-37
BOTTOM END	04-43
CLEANING	04-44
DISASSEMBLY	04-44
INSPECTION	04-44
ASSEMBLY	04-44
BREAK-IN	04-46
LEAK TEST AND ENGINE DIMENSION MEASUREMENT	04-47
LEAK TEST	04-47
PREPARATION	04-47
PROCEDURE	04-47
FINALIZING REASSEMBLY	04-49
ENGINE LEAK VERIFICATION FLOW CHART	04-50
ENGINE DIMENSION MEASUREMENT	04-51
CYLINDER HEAD WARPAGE	04-51
CYLINDER TAPER	04-51
CYLINDER OUT OF ROUND	04-51
COMBUSTION CHAMBER VOLUME MEASUREMENT	04-51
USED PISTON MEASUREMENT	04-53
CYLINDER/PISTON CLEARANCE	04-53
RING/PISTON GROOVE CLEARANCE	04-55
RING END GAP	04-55

SECTION 04 - ENGINE PREPARATION

CRANKSHAFT DEFLECTION	04-55
CONNECTING ROD BIG END AXIAL PLAY	04-56
CRANKSHAFT END-PLAY	04-56
CHECKING CRANKSHAFT ALIGNMENT	04-56
CDI SYSTEM.....	04-57
DENSO TRIGGER COIL IGNITION SYSTEM.....	04-57
CLEANING	04-60
DISASSEMBLY	04-60
ASSEMBLY	04-61
OIL INJECTION SYSTEM.....	04-62
OIL INJECTION PUMP	04-62
OIL TYPE	04-63
OIL SYSTEM LEAK TEST.....	04-63
OIL PUMP IDENTIFICATION	04-63
CLEANING	04-64
DISASSEMBLY	04-64
ASSEMBLY	04-64
ADJUSTMENT.....	04-64
CHECKING OPERATION	04-65
COOLING SYSTEM LEAK TEST	04-67
INSPECTION	04-67
DRAINING THE SYSTEM.....	04-67
DISASSEMBLY AND ASSEMBLY.....	04-67
COOLING SYSTEM REFILLING PROCEDURE	04-68
REWIND STARTER.....	04-69
INSPECTION	04-71
REMOVAL	04-71
ROPE REPLACEMENT.....	04-71
DISASSEMBLY	04-71
ASSEMBLY	04-72
INSTALLATION.....	04-74

ENGINE TUNING CAUTIONS

Here are a few items to keep in mind when working with your engine.

If you are in stock classes, know what adjustments are legal.

Modifications to the power curve of an engine will require recalibration of the transmission.

The lower the RPM at which you can generate the torque you need, the higher the percentage of that power that will reach the track.

Sloppy engine modification usually results in less power than you had stock.

Use the proper octane gasoline for your engine (Modification may require higher octane.).

Correct your carburetor jetting for the atmospheric conditions which exist at the time as close as possible to the time you will be competing.

Follow the assembly and disassembly procedures outlined in the appropriate *Shop Manual*.

BASIC ENGINE THEORY

Terminology

CYCLE	In a combustion engine, a cycle is accomplished when the four (4) phases; intake, compression, ignition and exhaust are complete.
TDC	Top Dead Center: The position of the piston when it reaches the upper limit of its travel inside the cylinder. BTDC: Before Top Dead Center ATDC: After Top Dead Center
BDC	Bottom Dead Center: The position of the piston when it reaches the lower limit of its travel inside the cylinder. BBDC: Before Bottom Dead Center ABDC: After Bottom Dead Center
BORE	Diameter of the cylinder.
STROKE	The maximum movement of the piston from BDC to TDC. It is characterized by 180° of crankshaft rotation.
COMBUSTION CHAMBER	Space between cylinder head and piston dome at TDC.
DISPLACEMENT	The volume of the cylinder displaced by the piston as it travels from TDC to BDC. The formula is: $\frac{\text{Bore}^2 \times \text{Stroke} \times \pi}{4} \times 20$ = ($\pi = 3.1416$) Expressed in cc (cubic centimeters)
NOTE: To transfer cc to cubic inches, divide cc by 16.387.	
COMPRESSION	Reduction in volume or squeezing of a gas.

SECTION 04 - ENGINE PREPARATION

Combustion Process

NORMAL COMBUSTION

Since the beginning of this study we have spoken of air/fuel mixture combustion rather than explosion. This combustion is a slow then accelerated burning of the mixture within the combustion chamber. Ignition occurs with the firing of the spark plug.

This initial process generates heat and pressure which in turn, is transmitted by conduction to the contiguous portion of the unburned mixture. When this portion has reached the point of self-ignition it starts to burn releasing more pressure and heat.

This burning action, called a flame front, travels at a speed of approximately 30.3 m (100 feet) per second until all mixture is burned, thus providing maximum piston thrust.

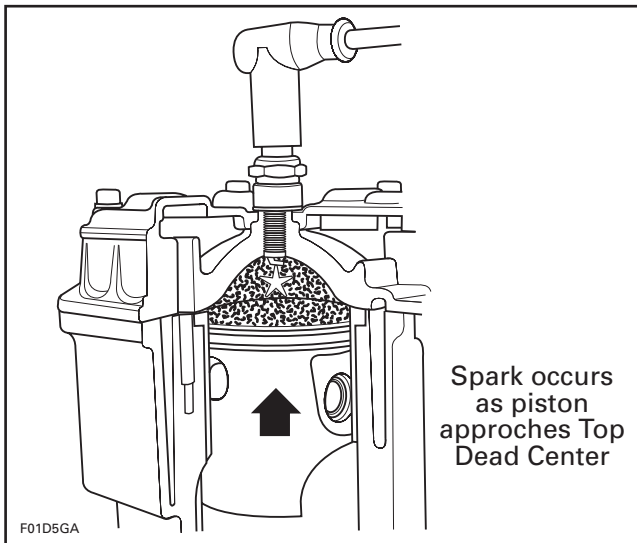
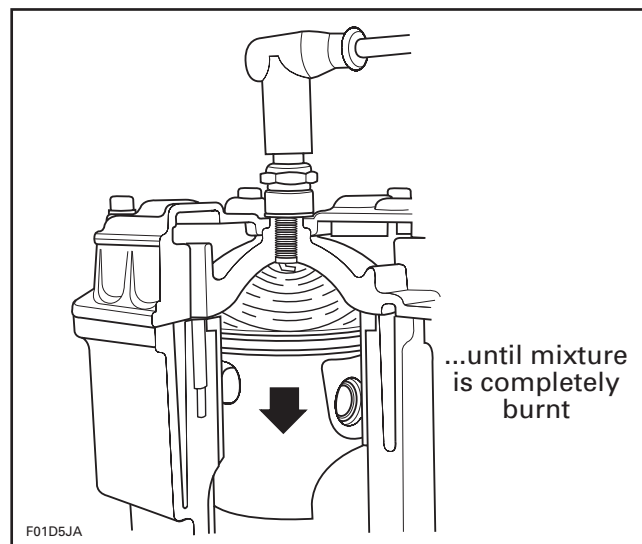
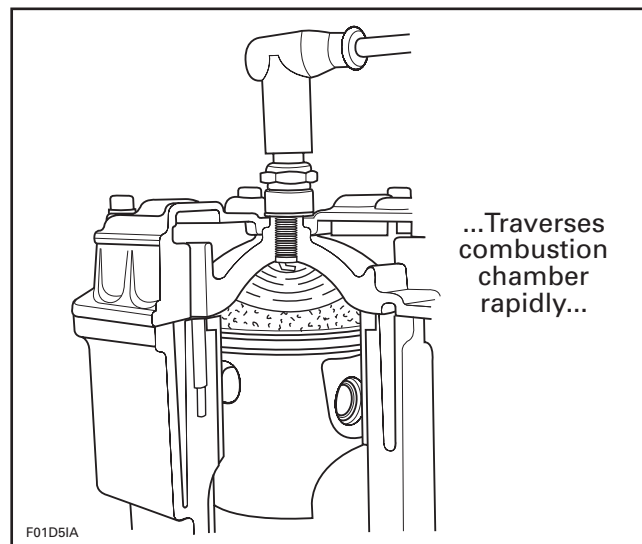
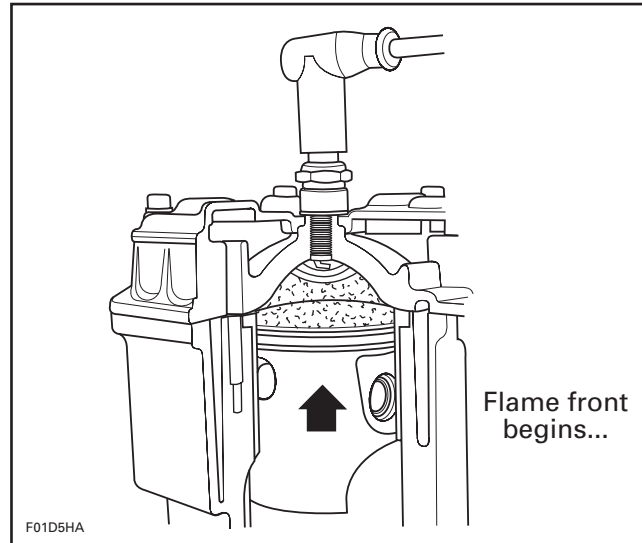

With all operating parameters correct, normal combustion will take place. However, if for some reason the temperature inside the cylinder is increased during combustion, abnormal combustion will occur and lead to serious engine damage.

DETONATION

In detonation, the spark plug initiates burning and the air/fuel mixture starts to burn in the usual manner but as combustion continues, the heat generated affects the large portion of the yet unburned air/fuel mixture.

This unburned mixture temperature becomes so high that it burns spontaneously creating high-velocity pressure waves within the combustion chamber.

These shock waves can sometimes be heard as pinging. While these shock waves can be detrimental to the mechanical integrity of the engine, it is the excessive heat that causes most problems in 2-strokes. The piston may expand excessively causing a seizure or the piston may melt. The melting will occur at the hottest points, which will be right below the spark plug and around the edge of the piston — often at a ring locating pin. If allowed to continue, a hole may melt completely through the top of the piston.

PRE-IGNITION

Pre-ignition is the ignition of the mixture inside the combustion chamber before the timed spark. Pre-ignition sources are generally an overheated spark plug tip or a glowing carbon deposit on the piston head. Since ignition occurs earlier than the timed spark, the hot gases stay longer in the combustion chamber, thus increasing cylinder head and piston temperatures to a dangerous level.

Usually the piston is subject to damage. It may seize or the aluminum on the exhaust side of the piston dome may melt. Pre-ignition is always preceded by detonation.

CAUSES OF DETONATION:

Octane of the fuel is too low.

Air/fuel mixture is too lean.

- a. Incorrect jetting.
- b. Air leaks.
- c. Varnish deposits in carburetor.
- d. Malfunction anywhere in fuel system.

Spark plug heat range too high.

Ignition timing too far advanced.

- a. Initial timing incorrect.
- b. Ignition component failure.

Compression ratio too high.

- a. Improperly modified engine.
- b. Deposit accumulation on piston dome or head.

Exhaust system restrictions.

- a. Muffler plugged/restricted.
- b. Tail pipe diameter too small.
- c. Incorrect design of expansion chamber.

General overheating.

- a. Broken fan belt.
- b. Loss of coolant.
- c. Lack of snow on heat exchangers.

Coolant or water entering combustion chamber.

SQUISH AREA

Rotax cylinder heads incorporate a squish area. This area is basically a **ledge** projecting beyond the combustion chamber area. In operation, as the piston ascends and approaches the ledge, a rapid squeezing action is applied to the air/fuel mixture contained in the area immediately between the piston dome and the ledge. This squashing action forces the entrapped mixture rapidly into the combustion chamber area, creating a greater mixture turbulence. Additionally, the small volume and large surface area of the squish band allow a better cooling of the end gases to help prevent detonation.

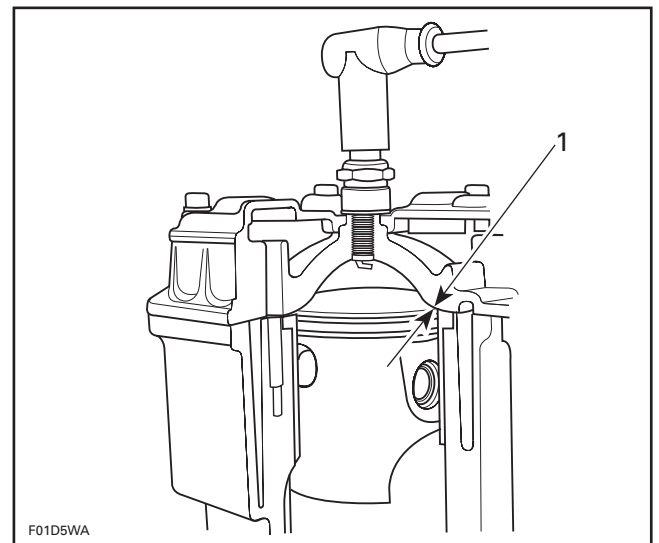

1. Squish area

SECTION 04 - ENGINE PREPARATION

If the squish clearance is increased, a loss in power will occur while too small a squish clearance will lead to detonation.

The squish clearance can be measured by inserting a piece of rosin core solder into the combustion chamber, rotating the engine through TDC, removing the solder and measuring the thickness of the compressed solder.

The solder should be inserted above and in line with the wrist pin. Measure the squish on both sides of piston as it may vary from side to side.

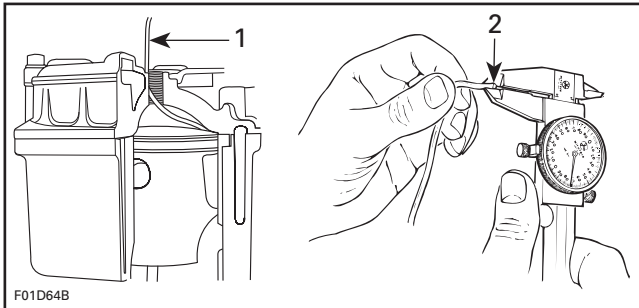

1. Solder
2. Flattened area

CAUTION: Do not use acid core solder; the acid can damage the piston and cylinder.

OPERATION OF THE RAVE VALVE

NOTE: Rave stands for Rotax Adjustable Variable Exhaust.

Theory

For a two-stroke-cycle engine to have high power capacity at high crankshaft speeds, a high volumetric or breathing efficiency is required and the fresh charge losses must be minimized. The result is achieved by opening the exhaust port early (94.5° BBDC) and utilizing the resonant effects of the tuned exhaust system to control fresh charge losses.

When an engine of this design is run at a medium speed, efficiency falls off quickly. The relatively high exhaust port effectively shortens the useful power stroke and because the exhaust system is tuned for maximum power, there is a large increase of fresh charge losses. As a result, the torque decreases along with a dramatic increase of the specific fuel consumption. Higher torque along with lower fuel consumption can be obtained at lower engine speeds if the time the exhaust port is open is shortened.

BOMBARDIER-ROTAX has patented a remarkably simple system to automatically change the exhaust port height based on pressure in the exhaust system.

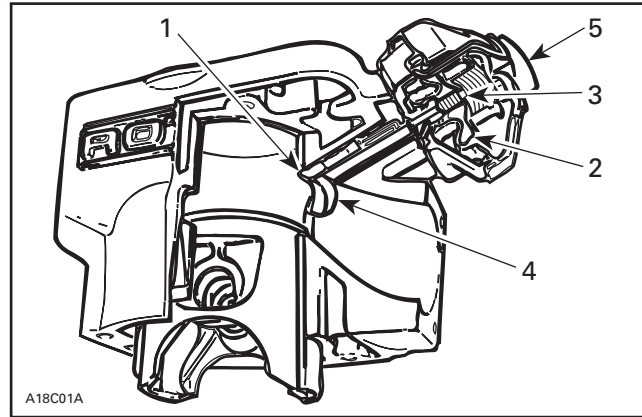

1. Guillotine
2. Diaphragm
3. Return spring
4. Exhaust port
5. Red plastic adjustment knob

Located above the exhaust port is a guillotine-type slide valve (item 1). This rectangular valve is connected by a shaft to a diaphragm (item 2) which is working against the return spring (item 3). Two small passages in the cylinder just outside the exhaust port (item 4) allow exhaust gas pressure to reach the diaphragm. As the throttle is opened and the engine begins producing more power, the pressure against the diaphragm will overcome the pressure of the return spring and the RAVE valve will open.

To the outside of the return spring is a red plastic adjustment knob (item 5). Turning the adjustment in or out changes the preload on the return spring which, in turn, will change the RPM at which the RAVE valve opens and closes. The exhaust port height changes a total of 4 mm to 6 mm (depending on engine type) from the RAVE valve fully closed to fully open.

Operation

The RAVE valve does not allow an engine to make higher peak horsepower than an engine not so equipped, it can make moving the peak higher practical because of its effect on the rest of the power curve. Item 2 in following illustration is the power curve of an engine with the RAVE valve held fully open through its entire RPM range. Item 6 notes the peak power produced. That peak will not change if the exhaust port time of a similar engine without a RAVE valve was the same (with all other features equal).

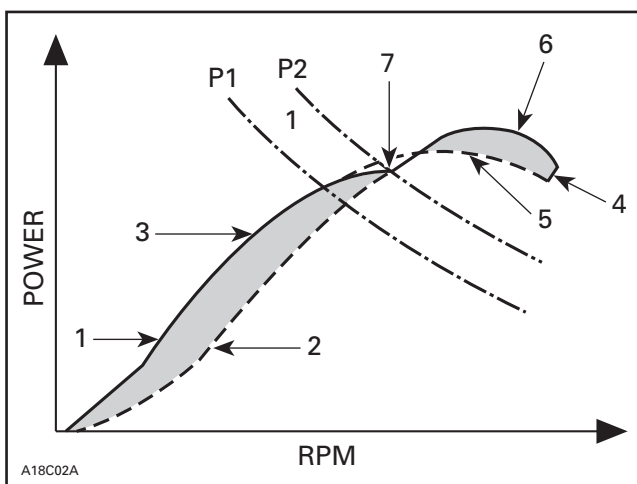

Item 1 is the power curve of the engine with the RAVE closed through its entire RPM range. The shaded area (item 3) is the improvement in power at lower engine speeds that is gained because of the lower exhaust port. If the port remains at this height, however, the power would peak as noted in item 5. Raising the exhaust port at the proper RPM (item 7) will allow the engines peak power to continue to rise to item 6.

Item P1 in the illustration is the pressure of the return spring against the diaphragm. The exhaust pressure must be high enough to overcome this pressure before the valve begins opening. Item P2 is the pressure required to completely open the RAVE valve. Between P1 and P2, the usable power curve of the engine is moving from power curve 1 to power curve 2. This transition takes place very rapidly at full throttle and from a practical standpoint can be considered to be instantaneous at item 7 which for the type 583 engine is at 6300 - 6400 RPM. Gradual application of the throttle, however, will result in the RAVE valve opening much later, i.e. 7300 - 7500 RPM.

If the RAVE valve opens too late, the engine will bog or hesitate momentarily as the RPM increases. Full peak performance (item 6) is still available. From a functional point of view, it is better to have the valve open a bit early than a bit late. This fact is due to certain dynamic conditions that exist on the snowmobile, i.e., the clutch and torque converter.

Adjustment

The red cap on the RAVE valve cover should be turned all the way in and bottomed in normal use. Backing the red adjuster out will reduce the spring preload and allow the RAVE valve to open at a lower RPM.

At high altitudes, exhaust gas pressures will drop and the spring preload may have to be decreased. It is doubtful that any adjustment will be required up to an altitude of 2400 m (8000 ft). Above that, however, the spring preload can be reduced by turning the red adjustment screw out up to a maximum of four turns.

The only other time adjustment of the spring preload should be considered is if the engine has been modified in any way.

AVAILABLE RAVE SPRINGS

Spring P/N	Wire Dia. mm (in)	Free Length mm (in)	Preload in N (LBF) at Compressed Length of 14 mm (.551 in)
420 239 948	1.0 (.039)	38.0 (1.50)	19.5 (4.37)
420 239 944	0.9 (.035)	48.5 (1.91)	15.9 (3.56)
420 239 942	0.8 (.031)	42.5 (1.67)	7.3 (1.64)
420 239 941	0.8 (.031)	52.5 (2.07)	10.5 (2.36)

Maintenance

There are no wear parts anywhere in the system and there are no adjustments to be periodically checked. The only possible maintenance required would be cleaning of carbon deposits from the guillotine slide. Cleaning intervals would depend upon the user's riding style and the quality of the oil used. Using Ski-Doo oil, we would suggest annual cleaning of the valve. If a customer uses a lower quality, high ash oil, more frequent cleaning may be required.

No special solvents or cleaners are required when cleaning the valve.

SECTION 04 - ENGINE PREPARATION

Bench Test for Checking RAVE Valve Operation

The operation of the valve can be checked by pressurizing the engine as one would when checking for crankcase leaks.

The engine must be sealed at all exhaust flanges, all carburetor inlets, and at the fuel pump impulse fitting. Depending on the design of your pressure test kit, you may be pressurizing the engine through the crankcase or right at the exhaust flange cover plate. If you are pressurizing through the crankcase, make certain the piston uncovers the exhaust port on the side you are checking.

Install the RAVE valve movement indicator (P/N 861 725 800) in place of the red plastic adjuster on the diaphragm cover so that you can observe the diaphragm movement.

The movement indicator must be turned all the way in to provide maximum spring pre-load. As you begin pressurizing the engine using engine leak tester kit (P/N 861 749 100), you will find the RAVE valve beginning to move at 5 kPa (0.7 PSI or 20 inches of water) and the valve will be fully displaced when you reach 10 kPa (1.4 PSI or 40 inches of water).

NOTE: Due to the low pressure conditions when using the leak tester kit (P/N 861 749 100) to check the RAVE valve operation, install a gauge with a range of 0-200 inches of water (P/N 861 749 100) on leak tester. As reference 6.89 kPa 1 (PSI) = 27.71 inches of water.

Troubleshooting

SYMPTOM	CAUSE	REMEDY
Engine revs 500 to 1000 RPM lower than its maximum operational RPM; Rave valve is not opening.	1. Bent valve rod	Replace
	2. Stuck valve	Clean
	3. Wrong spring tension (too high)	Replace
	4. Clogged passages	Clean
	5. Damaged bellows or clamp(s)	Replace
Engine hesitation in mid RPM range and full peak performance is available only after a while. Rave valve opens too early.	1. Broken or weak spring	Replace
	2. Adjustment screw too far out	Turn until it bottoms
	3. Valve stuck open	Clean

SKI-DOO utilizes cylinder reed induction technology on the new Series 3 twin cylinder engines. This technology is beneficial in three ways.

1. It uses less parts, (i.e. shafts, rotary valve discs, etc.). Resulting in a lighten engine package.
2. This technology results in positive control of fuel mixture, while providing a straight pathway to the intake and transfer ports as it is not obstructed by the rotating crankshaft.
3. By locating the carburetors higher on the engine this design allows for lower engine placement in the chassis.

SECTION 04 - ENGINE PREPARATION

BASE GASKETS		
377	P/N 420 931 781	0.4 mm
443	P/N 420 931 780	0.3 mm
	P/N 420 931 781	0.4 mm
503	P/N 420 931 782	0.6 mm
	P/N 420 831 856	0.3 mm
	P/N 420 831 858	0.4 mm
453	P/N 420 831 859	0.6 mm
	P/N 420 931 580	0.3 mm
	P/N 420 931 581	0.4 mm
	P/N 420 931 583	0.5 mm
493	P/N 420 931 582	0.6 mm
	P/N 420 931 584	0.8 mm
	P/N 420 931 588	0.5 mm
	P/N 420 931 589	0.8 mm
494	P/N 420 931 960	0.7 mm
	P/N 420 931 587	0.6 mm
	P/N 420 931 361	0.4 mm
	P/N 420 931 360	0.3 mm
593	P/N 420 931 362	0.6 mm
	P/N 420 931 582	0.6 mm
	P/N 420 931 962	0.7 mm
693	P/N 420 931 583	0.5 mm
	P/N 420 931 584	0.8 mm
	P/N 420 931 892	0.6 mm
	P/N 420 931 893	0.5 mm
699	P/N 420 931 894	0.7 mm
	P/N 420 931 895	0.8 mm
	P/N 420 931 570	0.3 mm
	P/N 420 931 571	0.4 mm
793	P/N 420 931 572	0.6 mm
	P/N 420 931 838	0.5 mm
	P/N 420 931 837	0.6 mm
	P/N 420 931 964	0.7 mm
809	P/N 420 931 839	0.8 mm
	P/N 420 931 620	0.3 mm
	P/N 420 931 621	0.4 mm
	P/N 420 931 622	0.6 mm

CARBURETION

Carburetor Main Jet Correction Chart

CARBURETOR MAIN JET CORRECTION CHART								
								
FT/METER	°F/°C							
	- 60/ - 50	- 40/ - 40	- 20/ - 30	- 0/ - 20	+ 20/ - 5	+ 40/ - 5	+ 60/ - 15	+ 80/ - 25
0	111.10	107.40	103.70	100.00	96.30	92.60	88.90	85.20
2000/ 600	105.77	102.07	98.37	94.67	90.97	87.27	83.57	79.87
4000/ 1200	100.43	96.73	93.03	89.33	85.63	81.93	78.23	74.53
6000/ 1800	95.10	91.40	87.70	84.00	80.30	76.60	72.90	69.20
8000/ 2400	89.7	86.07	82.37	78.67	74.97	71.27	67.57	63.27
1000/ 3000	84.44	80.74	77.04	73.34	69.64	65.94	62.24	58.54

A01C47A

NOTE: When the answer gives an unavailable jet size, select the next highest (richer) jet.

Example:

With a 250 stock main jet, at an altitude of a 600 m (2000 ft) and a temperature of - 5°C (20°F):

$$250 \times \frac{90.97}{100} = 227; \text{ use } 230 \text{ jet.}$$

CAUTION: These values are guidelines only. Specific values/adjustments vary with temperature, altitude and snow conditions. Always observe spark plug condition for proper jetting.

This table is more than adequate for stock engines. Two-stroke engines with high specific outputs that are heavily modified (twin pipes, high compression, large carburetors, etc.) and performing at high RPM are very sensitive to air density changes. The following is a very accurate formula for correcting jetting.

First, a baseline for jetting must be established.

SECTION 04 - ENGINE PREPARATION

Jetting, horsepower, and B.S.F.C. data can be obtained with dyno testing but also confirmed with field testing. The tried and true method of determining mixture ratio is to inspect the parts of the engine that are directly exposed to the combustion process. The two best indicators are the spark plug and the piston dome. The color and where it is located are the two things to look for. Chocolate brown on the insulator, ground electrode, and piston dome indicate a proper mixture. The ground electrode should show a difference in color just at the radius of the electrode.

The engine must be operated under load for at least one minute to obtain accurate readings.

Establish the C.R.A.D. by using the following formula:

$$\text{C.R.A.D.} = \frac{1737.97 \times \text{C.A.P.}}{460 + T}$$

C.A.P. = Corrected air pressure

C.A.P. = B - E

B = Barometric pressure readings (in - Hg)

E = Vapor pressure = $\left(\text{S.P.} \times \frac{\text{R.H.}}{100} \right)$

See saturation pressure (chart 1).

S.P. = Saturation pressure (in - Hg)

R.H. = Relative humidity (%)

Record the C.R.A.D. when correct jetting has been established. This is your base line for future use.

Example: Testing established a 400 main jet at C.R.A.D. of 100%. One week later, the C.R.A.D. at the track is 110%. Use the following formula to establish the new main jet.

$$\text{New main jet} = \frac{\text{New C.R.A.D.} \times \text{Baseline main jet}}{\text{Base line C.R.A.D.}}$$

Example: $\frac{110 \times 400}{100}$

New main jet = 440

Record the C.R.A.D. when correct jetting has been established. This is the baseline for future use. Jetting corrections for a different C.R.A.D. can be obtained with the following ratio:

$$\text{New main jet} = \frac{\text{New C.R.A.D.} \times \text{Base line M.J.}}{\text{Base line C.R.A.D.}}$$

Example: Testing results in a 570 M.J. at a C.R.A.D. of 105.4%. Two weeks later at the race track, the C.R.A.D. is 110.9%.

$$\text{The new M.J.} = \frac{110.9 \times 570}{105.4}$$

New M.J. = 600

Useful Equations

$$\text{C.F.} = \frac{29.92}{B - E} \times \frac{460 + T}{520}$$

C.A.P. = B - E

$$\text{C.R.A.D.} = \frac{1737.97 \times \text{C.A.P.}}{460 + T}$$

Where:

B = barometer reading (in-Hg)

E = vapor pressure (in - Hg) = $\text{S.P.} \times \frac{\text{R.H.}}{100}$
or use wet bulb/dry
bulb temperature and
psychrometric chart

T = carb. inlet air temp (°F)

S.P. = saturation pressure (in-Hg)

R.H. = relative humidity (%)

C.A.P. corrected air pressure (in-Hg)

C.HP = Corrected brake horsepower

B.S.F.C. = Brake specific fuel consumption

C.R.A.D. = Corrected relative air density (%)

E.G.T. = Exhaust gas temperature

W.O.T. = Wide open throttle

SECTION 04 - ENGINE PREPARATION

SATURATION PRESSURE (CHART 1)	
T = TEMP. (°F)	S.P. = SATURATION PRESSURE (in-Hg)
- 40	.004
- 30	.008
- 20	.012
- 10	.020
0	.040
5	.055
10	.070
15	.090
20	.110
25	.140
30	.170
35	.208
40	.247
45	.314
50	.380
55	.450
60	.521
65	.630
70	.739
75	.884
80	1.030
85	1.225
90	1.420
95	1.675
100	1.930

Most racers use an air density gauge. This gauge is fairly inexpensive. It basically establishes C.R.A.D. for you by combining the variables on any given day.

First, establish a base line main jet by testing.

After you have determined the correct main jet, record the jet number and the air density gauge reading.

Example: Base line

Gauge reading 90

Main jet 300

The next day at the track, your air density gauge now reads 105. This means you have gained 15% air density.

New density 105

Base line 90

$105 - 90 = 15$

Multiply your base line main jet by 115.

Example: $300 \times 115 = 345$

Round off to next highest jet size.

New main jet = 350

Air density can change rapidly during the course of the day. Check your gauge frequently. Always use the same gauge for a different gauge may read differently.

SECTION 04 - ENGINE PREPARATION

Exhaust Gas Temperature Probe Location

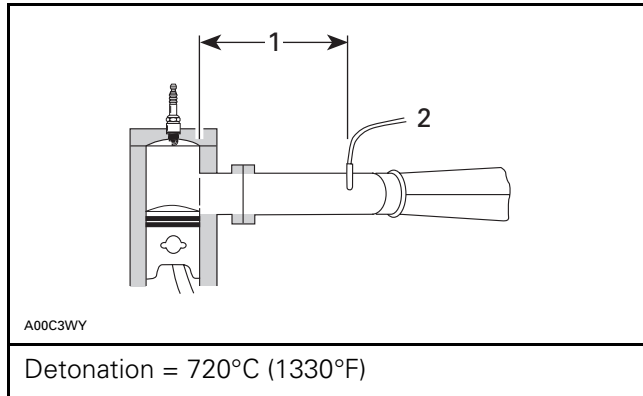

1. 100 mm from piston
2. Probe

NOTE: Temperature at wide open throttle at maximum HP RPM.

Exhaust gas temperatures (E.G.T.'s) can also give an indication of mixture ratio. At wide open throttle (W.O.T.) at maximum HP RPM, a leaner mixture will produce higher E.G.T.'s and a richer mixture will result in lower E.G.T.'s. (E.G.T.'s are not absolute. Engines have seized with E.G.T.'s in the allowable range).

Carburetor Operation

The operation of the carburetor is based on the physical principle that fluids (air is a fluid) under pressure gain speed but lose pressure when passing through a converging pipe (venturi).

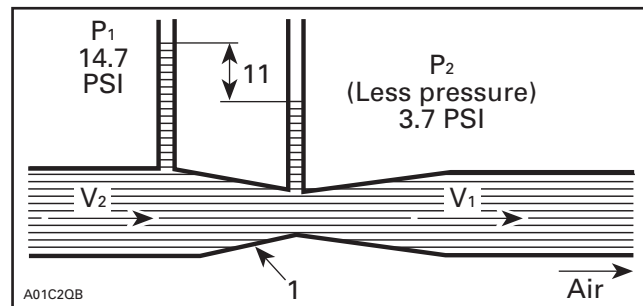

1. Venturi

Air entering the bell of the carburetor has a speed of V_1 and pressure of P_1 . As the air is forced into the smaller diameter of the venturi, speed increases (V_2) but pressure drops (P_2).

Passages in the carburetor connect the venturi to a reservoir of fuel (float bowl). The float bowl is vented to the atmosphere (P_1). P_1 is greater than P_2 so fuel is pushed from the bowl to the venturi via the jets and passages. Varying the size of jets varies the amount of fuel the engine receives. Engine speed is controlled by varying the amount of air/fuel mixture that the engine receives.

Liquid gasoline does not burn, so for the engine to run efficiently, the fuel must be broken down into small droplets, and mixed with the oxygen molecules in the incoming air. This is referred to as atomization. The shape of the venturi and the shape and location of the jets and fuel delivery passages will determine how well the fuel and air are mixed.

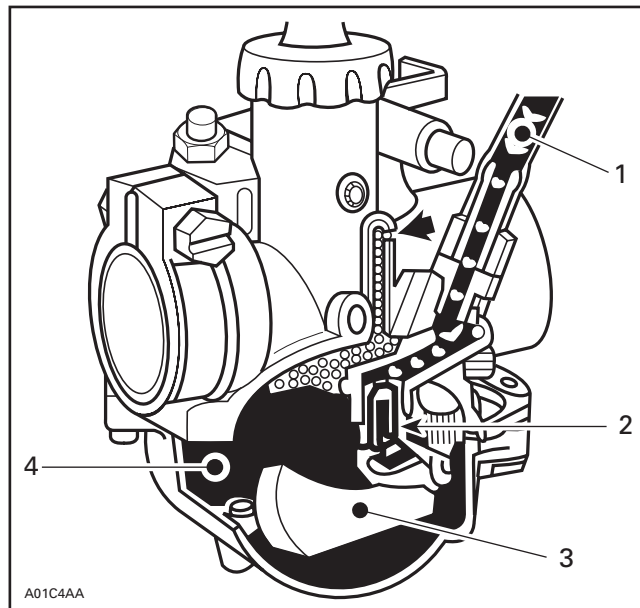

1. Float bowl
2. Needle valve
3. Float
4. Fuel inlet

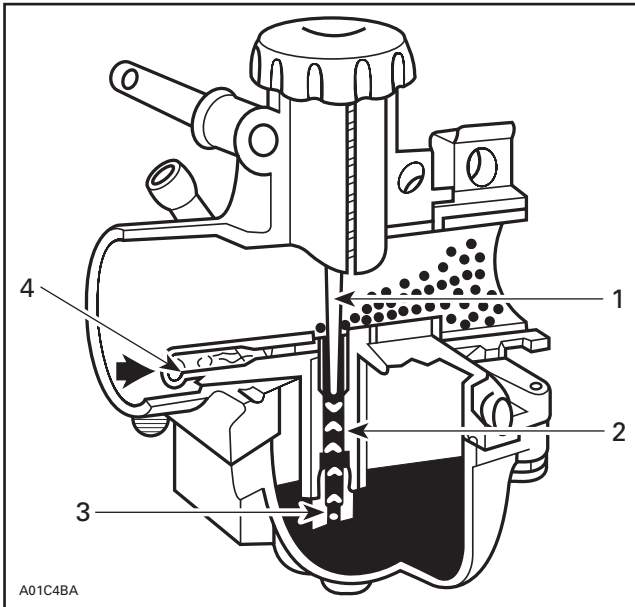

1. Jet needle
2. Needle jet
3. Main jet
4. Air jet

MIKUNI VM AND TM TYPE CARBURETORS

Snowmobile engines are operated under a wide range of conditions, from idling with the throttle valve remaining almost closed to the full load (the maximum output) with the throttle valve fully opened. In order to meet the requirements for the proper mixture ratio under these varying conditions, a low-speed fuel system (the pilot system) and a main fuel system (the main system) are provided in Mikuni VM and TM type carburetors.

While this text covers the VM-type carb., the TM flat slide carb. functions the same. The circuits function the same and tuning a TM would be done in the same manner as the VM.

TM 40 CARBURETORS

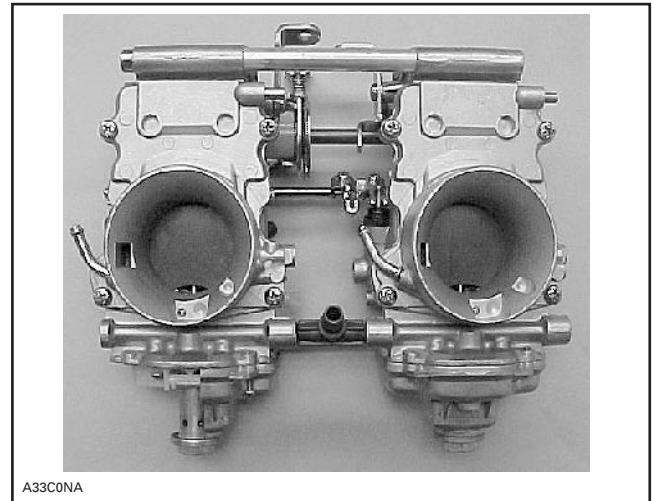

The TM 40 carburetor "rack" system is used on all liquid cooled engine models except the 2003 MX Zx 440 REV. While they are considerably different than the VM's of years ago and have a similar appearance to the TMX style of the 440 REV, the basic circuit operations remain the same. There are very few interchangeable components between the 3 styles. This section will give you a brief overview and component location of the TM 40. This is not to replace the shop manual of the model being used.

There is one common fuel inlet between both carburetors. It is sealed with O-rings to each carb body.

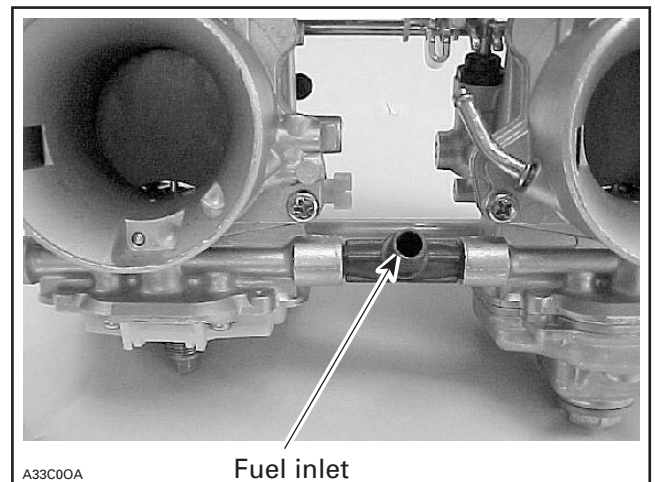

SECTION 04 - ENGINE PREPARATION

The inlet needle, seat and float are of integral construction, and must be replaced as a set. The float level is not adjustable. The floats are lightweight and placed high in the body of the carburetor to ensure consistent fuel levels even in extremely bumpy conditions.



The float bowl is sealed with an O-ring and held in place with one small Phillips screw and the Main Jet baffle.



The Main Jet is a standard Mikuni long hex.

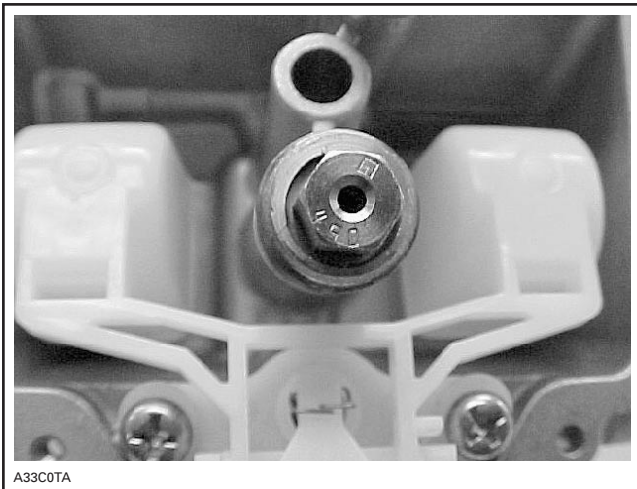

The Needle Jet is cast into the body of the carburetor and not removable.

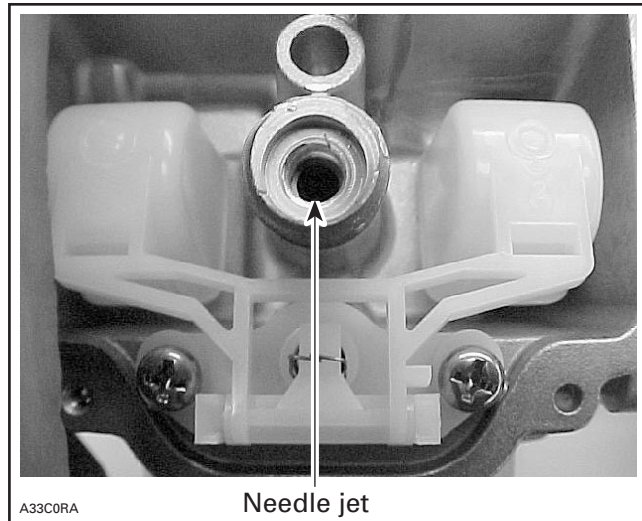
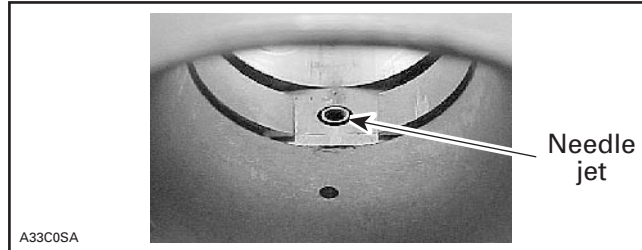

The Pilot Jet is similar to a VM, however it is extremely small. As an example the MXZ 800 uses a 17.5 Pilot Jet.

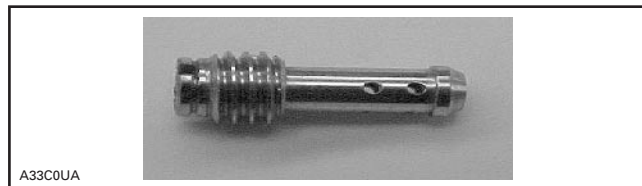

SECTION 04 - ENGINE PREPARATION

There is no pilot air-screw used, as on VM carburetor. Instead there is a low speed fuel screw on the engine side of the throttle slide. This screw controls fuel, so the more turns out, the richer the mixture becomes. **Do not forget this.**

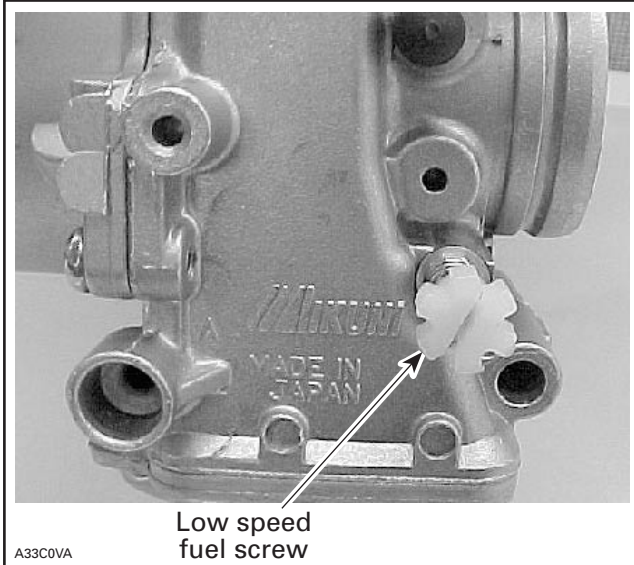

While the carburetor bore is round, the throttle slide has a flat guillotine shape. We can achieve faster throttle response from this type of carburetor design, especially in the midrange. Also, the air flow at WOT, or wide open throttle is slightly better than a similar sized VM. The slides are numbered for the cut-away as VM slides.

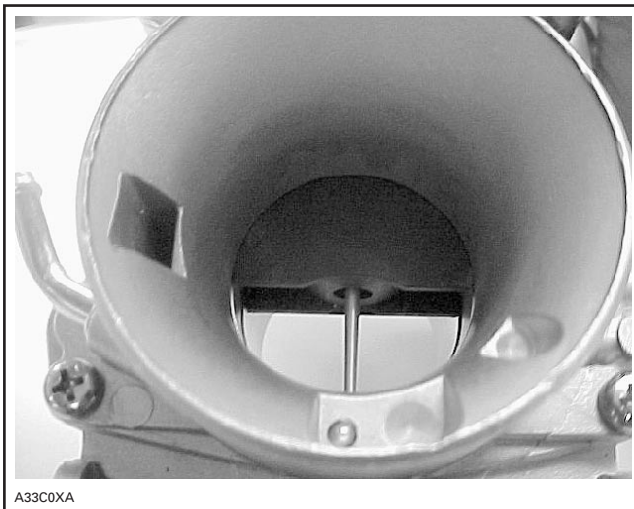

The Jet Needle is specifically made for TM style carburetor and are calibrated for each specific engine size. The e clip is not adjustable as only one groove is provided! **High altitude calibrations will normally require a different Jet Needle.**



A single idle speed screw is used to adjust both carburetors. The carbs are synchronized at the factory and nothing other than idle speed adjustment needs to be done unless the carburetors are disassembled. Refer to the appropriate shop manual for the correct procedure.

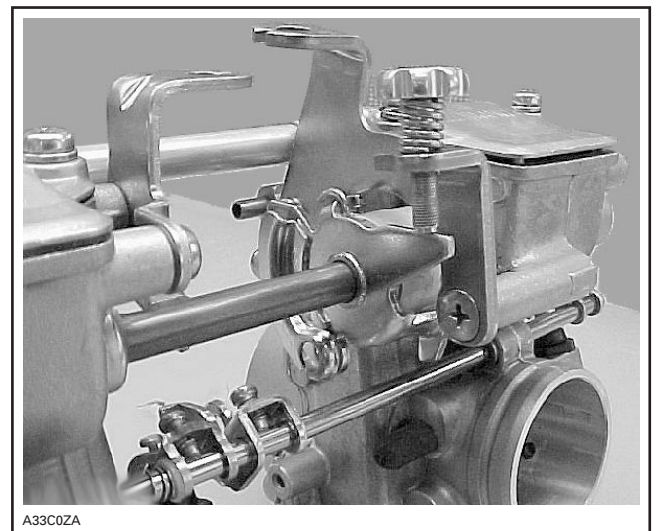

SECTION 04 - ENGINE PREPARATION

The float bowls are now vented to the air box. This gives us a much more precise calibration, especially at higher speeds since the pressure in the float bowl remains the same as the pressure in the carburetors' inlet.

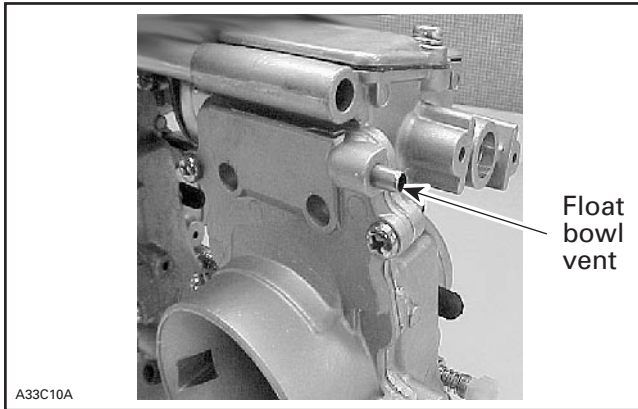

The TM carburetors have the ability to use the heated coolant from the engine to prevent ice buildup. Engine coolant is directed from the cylinder head through a user operable shut-off valve under the hood. It then passes through the PTO carb body, through a connecting hose to the MAG carb to warm the throttle slides. The coolant circulates back to the coolant bottle. This valve should normally be opened any time the temperature is around approximately 38°F (5°C).

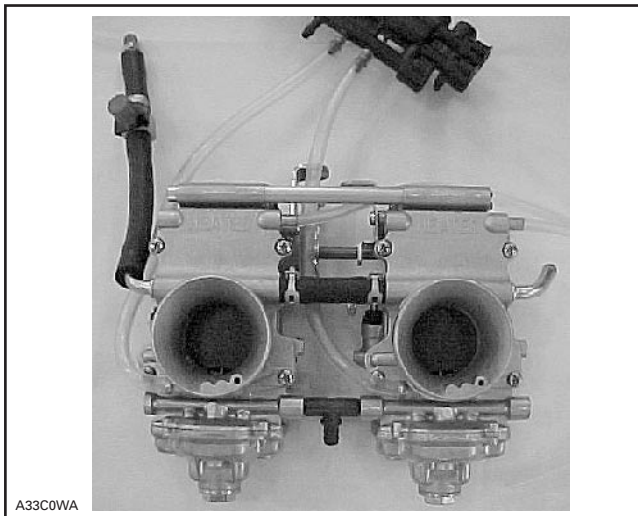

MIKUNI CARBURETOR (VM)

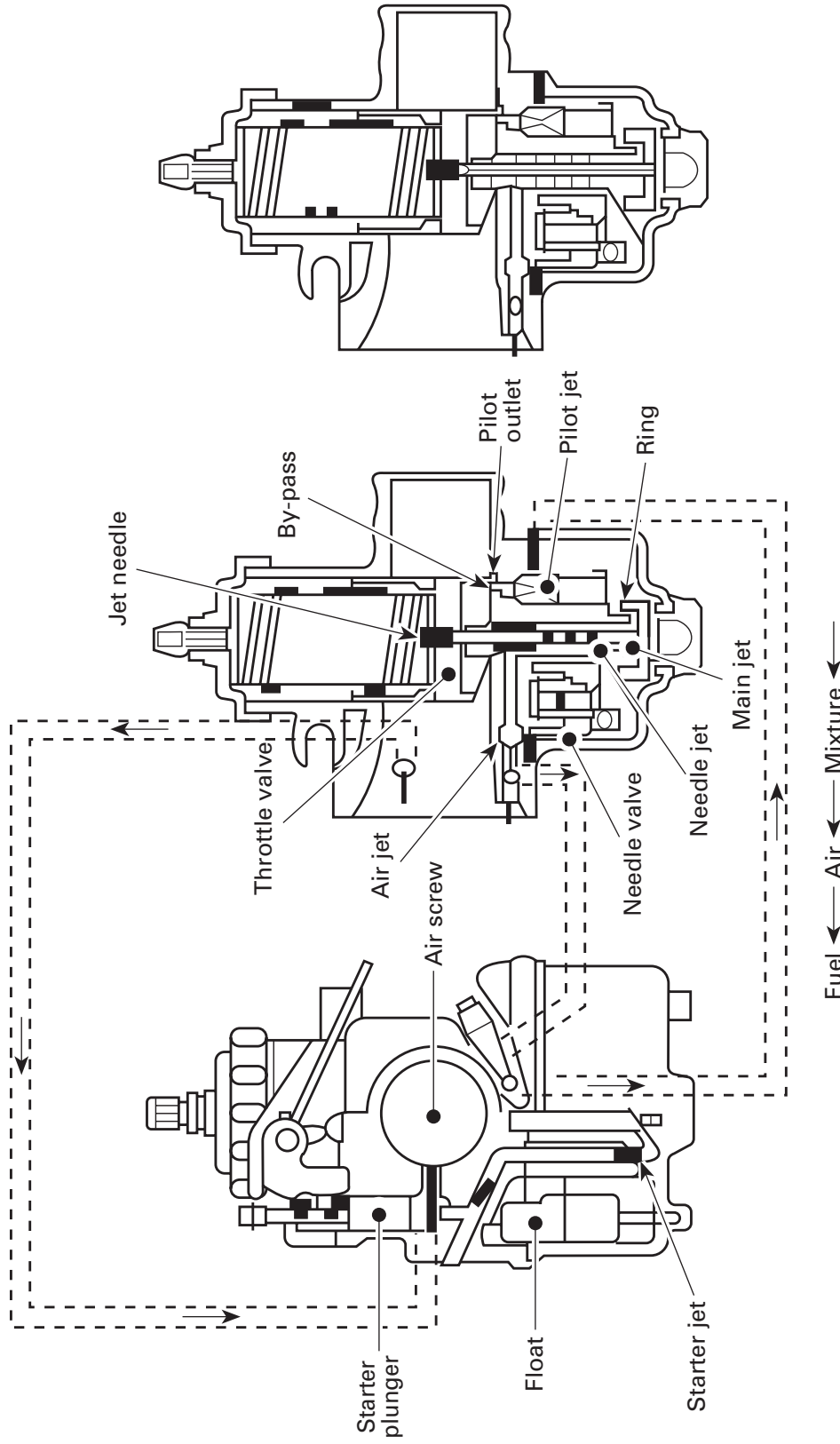

BLEED TYPE TYPE

PRIMARY TYPE

A01C4DS

SECTION 04 - ENGINE PREPARATION

Starting Device (enrichner)

Instead of a choke, the enrichner system is used on some Mikuni carburetors. In the starter type, fuel and air for starting the engine are metered with entirely independent jets. The fuel metered in the starter jet is mixed with air and is broken into tiny particles inside the emulsion tube. The mixture then flows into the plunger area, mixes again with air coming from the air intake port for starting and is delivered to the engine in the optimum air/fuel ratio through the fuel discharge nozzle. The starter is opened and closed by means of the starter plunger. Since the starter type is constructed so as to utilize the negative pressure of the inlet pipe, it is important that the throttle valve be closed when starting the engine.

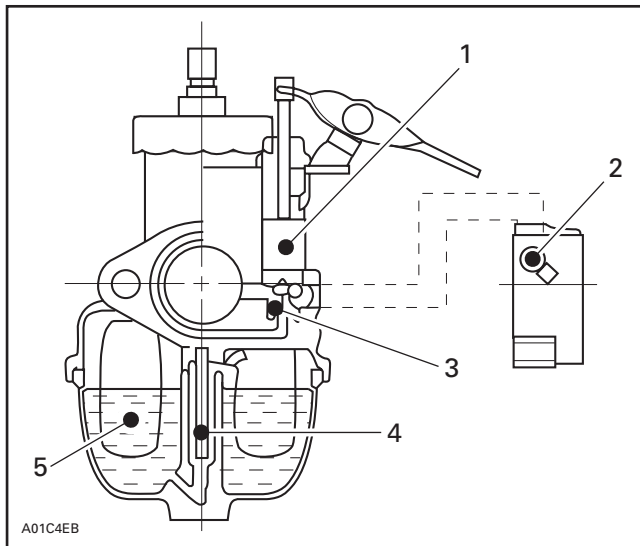

1. Plunger area
2. Emulsion tube
3. Inlet pipe
4. Needle jet
5. Float

Selection of the Aperture of Carburetor

One of the prerequisites for improving the output is to use a carburetor with as large an aperture as possible. However, a large aperture alone does not necessarily improve the output. As shown in the following illustration, it is true that a large aperture improves the power output in the high speed range. In the slow speed range, on the other hand, the output drops. The aperture of a carburetor is determined by various factors. These factors include (1) whether the vehicle is intended for racing, (2) the design of the engine, (3) driving technique of the driver, (4) the driver's preference, etc. In addition, the maximum output, the maximum torque and the minimum number of revolutions for stable engine operation must also be taken into account.

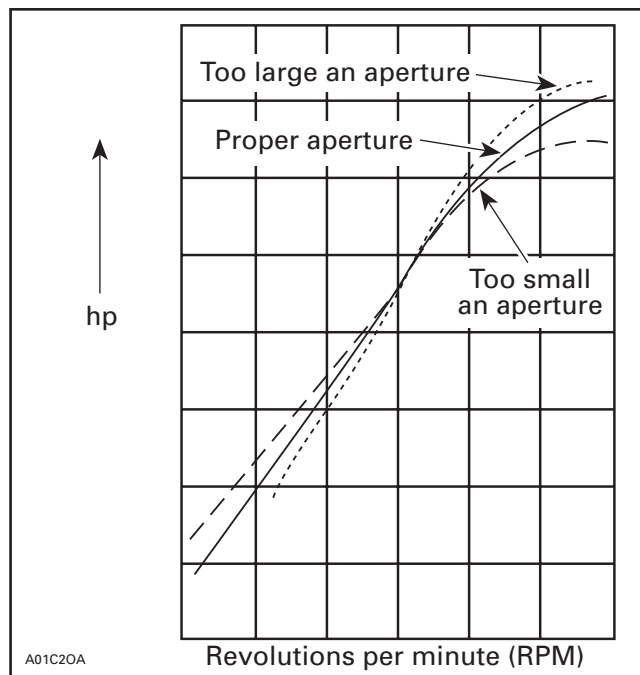

Size of Mikuni Carburetors

Mikuni VM-type carburetors come in various sizes, with the main bore ranging from 10 mm (.39 in) to 44 mm (1.73 in) (in even numbers for the most part.) The carburetor body is made of aluminum or zinc.

Carburetor Test

Once the aperture of the carburetor is determined, a test to select the proper jet should be made. The size of the jet is determined by measuring the output in a bench or in a chassis dynamo test. For racing, it is best to determine the proper size of the jet on the racing track, because the following points must be taken into account:

- a. The altitude (atmospheric pressure), temperature and humidity of the race track.
- b. The operation of the engine based on the topography of the race track.

Pilot/Air System

PRINCIPLES OF OPERATION

The pilot/air system controls the fuel mixture between idle and approximately the 1/4 throttle position. As the throttle is opened wider for low speed operation, the pilot outlet cannot supply adequate fuel, and fuel then enters the carburetor bore from the bypass as well as the pilot outlet. The pilot/air system is tuned by first adjusting the air screw; then, if necessary, by replacing the pilot jet.

Adjusting Air Screw

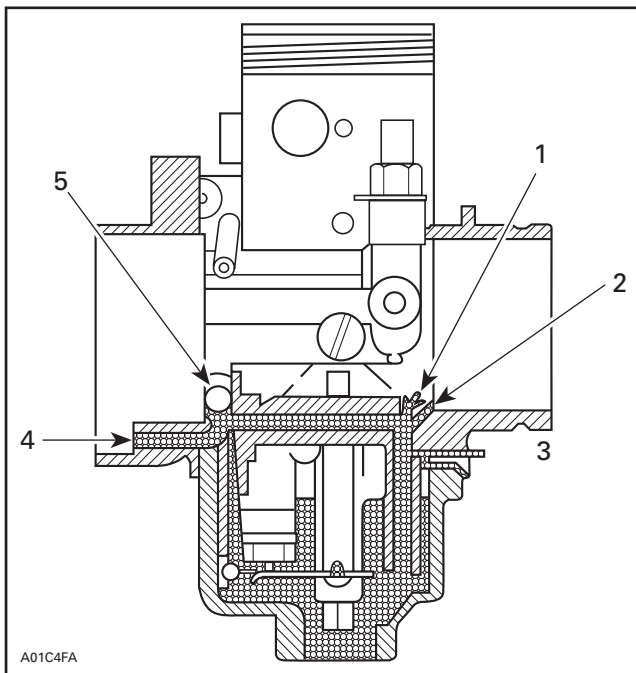

1. Pilot bypass
2. Pilot outlet
3. Pilot jet
4. Air intake
5. Air screw

NOTE: This procedure may be performed for single and dual carburetors. Never adjust screws more than 1/4 turn at a time.

1. Turn idle stop screw in until screw contacts throttle valve. Then turn idle stop screw in 2 additional turns.
2. Start and warm up engine. Adjust idle stop screw to 500 RPM above normal idle speed. See **Low-Speed Fuel System**.
3. Turn air screw in or out using 1/4-turn increments until engine RPM peaks or reaches its maximum RPM.
4. Readjust idle stop screw to return engine to normal idle speed. See pages **Low-Speed Fuel System**.
5. Repeat Steps 3 and 4 until engine operates at normal idle speed and air screw is peaked.
6. When air screw is adjusted stop engine. Note the setting of air screw and turn it all the way in. If it takes less than 1 turn, the pilot jet is too small and a larger one must be installed. If it takes more than 2-1/2 turns to set air screw, the pilot jet is too large and must be replaced by a smaller one.
7. Turn the air screw left and right (between 1/4 and 1/2 turn) and select the position where the engine revolution reaches the maximum. Adjust the throttle stop screw to bring down the engine revolution to your target speed for idling. After this adjustment of the throttle stop screw is made, select once more the position where the engine revolution reaches the maximum, by turning the air screw left and right (between 1/4 and 1/2 alternately). At this point, attention should be paid to the following points.
 - a. If there is a certain range in the opening of the air screw where the fast engine revolution can be obtained (for instance, the number of revolutions does not change in the range of 1-1/2 to 2.0 turns), it would be better for acceleration to 1-1/2 turns.

SECTION 04 - ENGINE PREPARATION

- b. To determine the **fully closed** position of the air screw, turn the air screw slightly. Excessive tightening of the air screw would damage the seat. The position where the air screw comes to a stop should be considered the **fully closed** position. The maximum number of turns in the opening of the air screw must be limited to 3.0. If the air screw is opened over 3.0 turns, the spring will not work and the air screw can come off during operation of the vehicle.

Replacing Pilot Jet

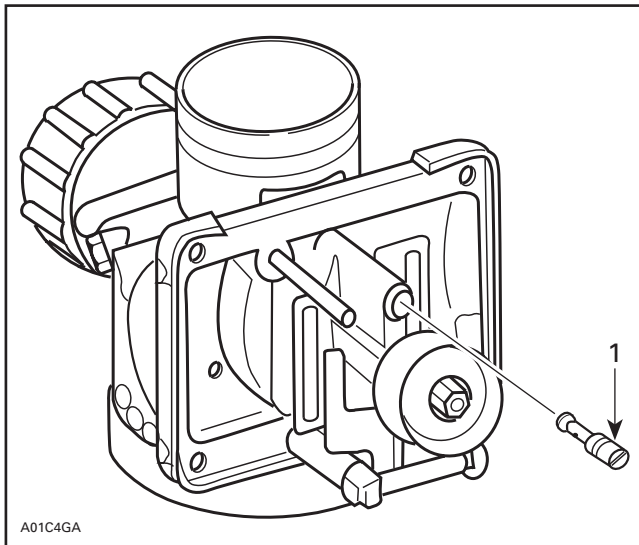

1. Pilot jet

Pilot jets are numbered from no. 15 (the smallest) to no. 80 (the largest). The number corresponds to fuel flow and not necessarily to drill size or through-hole diameter. After changing the pilot jet, check and adjust air screw as described above.

NOTE: Since the pilot/air system provides some fuel up to wide open throttle, changes in this system will affect the throttle valve, jet needle/needle jet, and main jet metering systems.

Throttle Valve

PRINCIPLES OF OPERATION

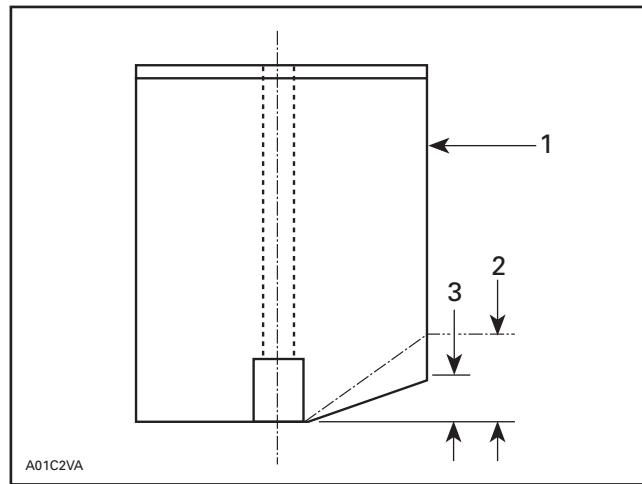

1. Throttle valve
2. 3.0
3. 2.0

The throttle valve is cut away on the air inlet side to help control the fuel/air mixture at low and intermediate throttle settings. The size of cut-away also affects acceleration.

Throttle valves are numbered from 0.5 to 4.5 in 0.5 increments based on the size of the cut-away. The most commonly used configurations are 1.5 to 3.5. The higher the number, the greater the cut-away and the larger the air flow.

The throttle valve functions in about the same range as the pilot/air system. After the air screw is adjusted, it can be used to check the throttle valve selection.

NOTE: Too lean of a slide cut-away can cause piston seizures during sudden throttle closures from large throttle settings.

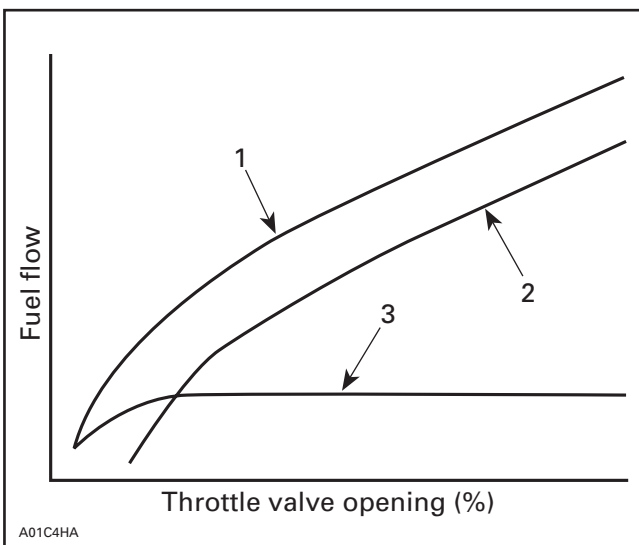

1. Total amount of fuel flow
2. Main fuel system
3. Pilot fuel system

CHECKING AND SELECTING THROTTLE VALVE

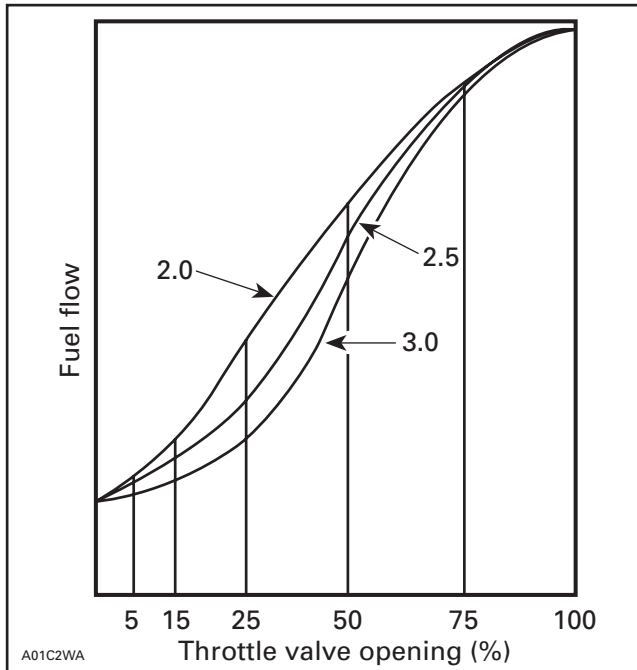

1. Operate engine at low throttle settings, accelerating from idle to 1/4 throttle.
2. If engine bogs during acceleration, there is probably insufficient fuel. Turn in air screw about 1/4 turn at a time. If engine acceleration is improved, after adjusting air screw, the throttle valve cut-away needs to be decreased.
3. If engine runs rough or smokes excessively during acceleration, there is probably too much fuel. Turn out air screw 1/4 turn at a time. If engine operation is improved, the throttle valve cut-away needs to be increased.

NOTE: Illustration above indicates fuel flow according to throttle valve size and the amount throttle valve is opened.

4. Increase or decrease throttle valve cut-away size in 0.5 steps.
5. Return air screw to its original setting and operate engine at low throttle settings. Accelerate engine from idle to 1/4 throttle; engine should accelerate smoothly.
6. As a final check, change the position of the air screw. If this does not significantly affect engine performance (as in steps 2 and 3), the throttle valve is correct.

Jet Needle

PRINCIPLES OF OPERATION

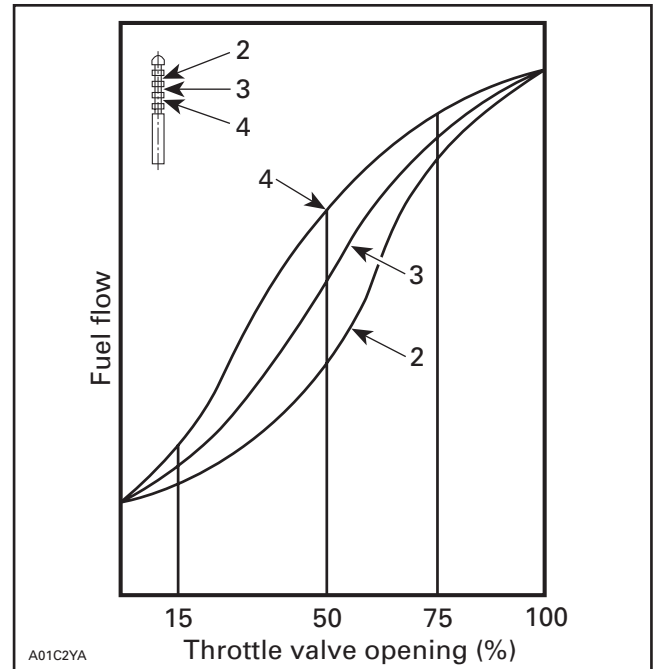

The jet needle works with the needle jet to increase the amount of fuel as the throttle valve is raised.

Although the jet needle and needle jet function in the 1/4 to 3/4 throttle range, they also affect the amount of fuel present at wide open throttle. When tuning the jet needle, also check main jet system operation.

SECTION 04 - ENGINE PREPARATION

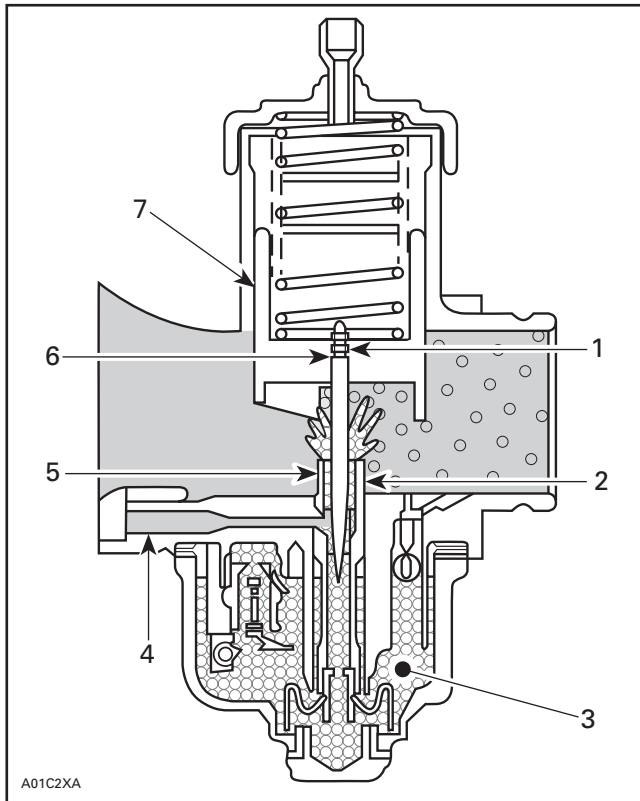

1. E-ring
2. Needle jet
3. Fuel
4. Air
5. Metered here
6. Jet needle
7. Throttle valve

The jet needle raises and lowers with the throttle valve which changes jet needle position in the needle jet. Because the jet needle is tapered from top to bottom, an increasing amount of fuel is delivered through the needle jet whenever the throttle valve is raised. Increased or decreased air flow, by the throttle valve position, regulates the amount of fuel through the needle jet and around the jet needle.

The jet needle works on combination of length, taper, and E-ring position. Each jet needle has a number and letter series stamped on the body.

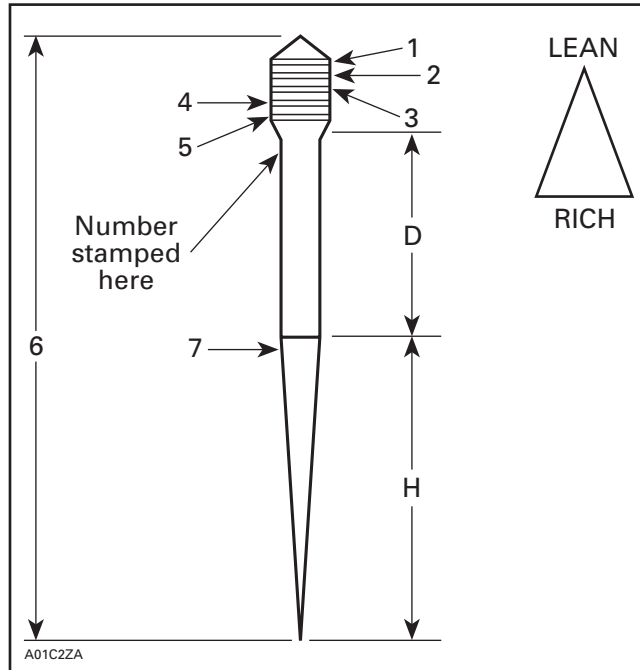

Example: 6DH7

6 - Basic length of needle.

DH - A single letter would indicate a single taper of the needle, double letter a double taper, and three letters mean there is a triple taper.

D - Amount of taper at top of needle.

H - Amount of taper at bottom of needle.

7 - Material, type of coating and start of second taper on needle.

NOTE: Letter designation of the jet needle indicates the angle of taper. Each letter (starting with A is 0.25° greater than preceding letter. Example: D = 1°, E = 1-1/4°, F = 1-1/2°, G = 1-3/4°, and H = 2°. This applies to both single and double taper needles.

At the top of the jet needle are five grooves numbered 1 through 5 from top to bottom. The number 3 or middle groove being the starting point for the E-ring. The E-ring position on any jet needle determines the rich or lean part throttle or mid-range carburetor operation.

Moving E-ring to position 1 or 2 lowers jet needle into needle jet and leans out the fuel/air mixture. Similarly, moving E-ring to position 4 or 5 raises jet needle in needle jet and enriches the fuel/air mixture.

POSITIONING THE E-RING

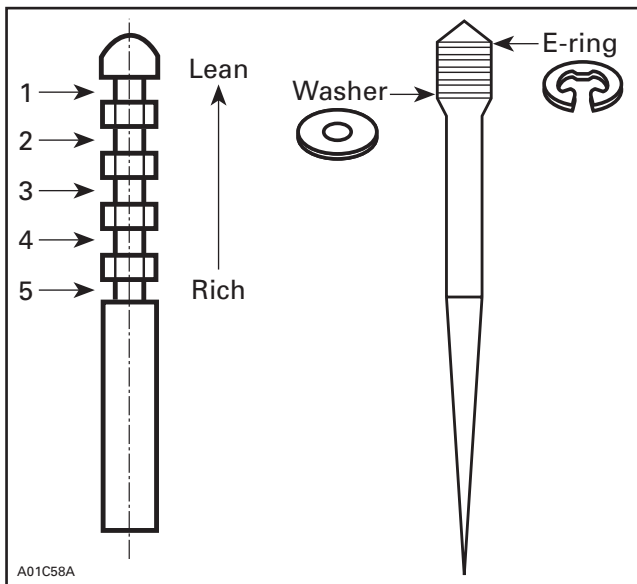

1 to 5 = E-ring position

1. Check for a rich or lean setting by examining exhaust manifold. A very light brown or white color indicates a lean mixture. A very dark brown or black color indicates a rich mixture. The proper color is tan.
2. Move E-ring one groove at a time to correct the fuel/air mixture.
3. If proper operation is obtained at all but the 3/4 throttle setting after the main jet has been tuned, operation may be improved by changing the jet needle taper. Do not, however, change the jet needle until main jet and E-ring position have been thoroughly checked.
4. If the E-ring is in the number 5 position and operation is still lean, a needle jet with a larger orifice may be installed. This may be done only after thoroughly checking the main jet, jet needle, and E-ring positions.

NOTE: Make sure washer is installed under E-ring on vehicles so equipped.

Needle Jet

PRINCIPLES OF OPERATION

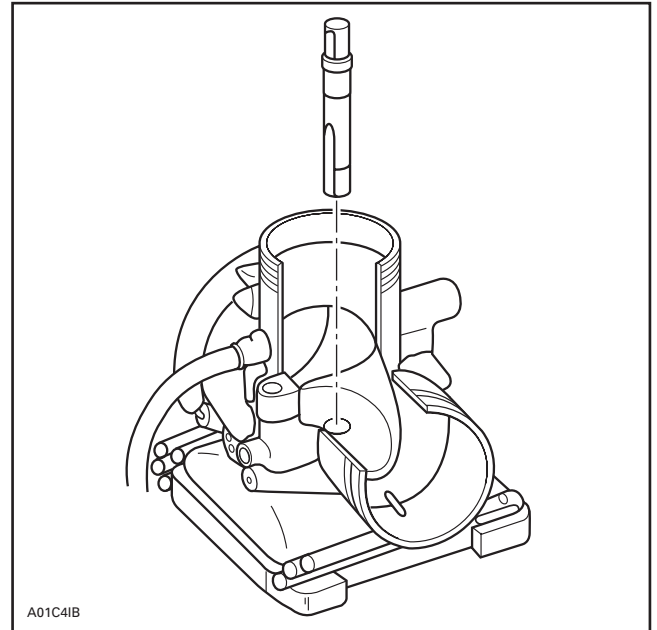

The needle jet works in combination with the jet needle to meter the fuel flow in the mid range.

Changes to the needle jet should be made only if the results of changing the jet needle position are unsatisfactory. In stock applications, except for specific calibration changes necessary at high altitudes, the needle jet should not be changed. Selection of the proper needle jet requires much care and experience. Decreasing the needle jet size can prevent the main jet from metering the proper amount of fuel at wide open throttle.

SECTION 04 - ENGINE PREPARATION

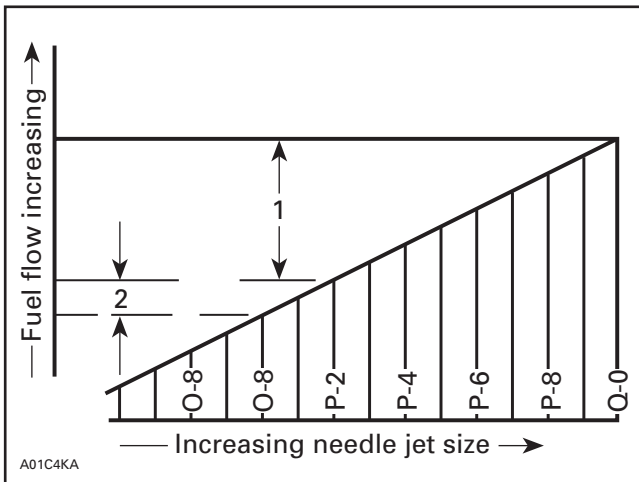
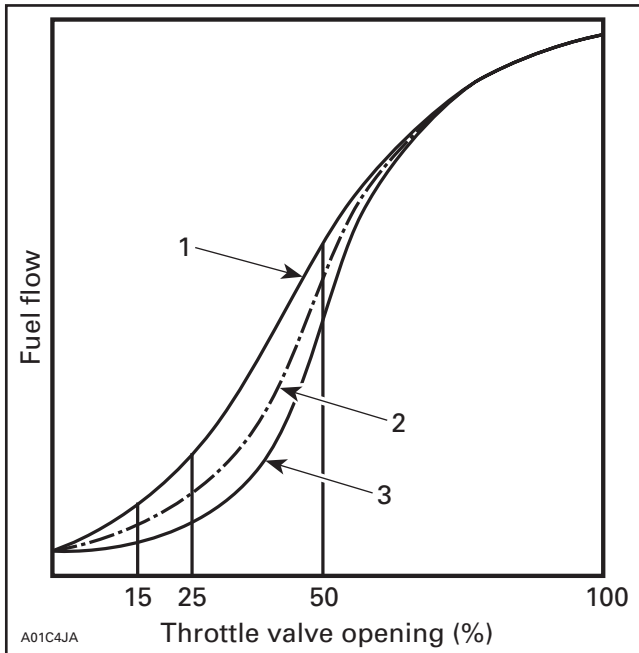

Needle jets are stamped with an alphanumeric code. The letter indicates a major change in fuel flow. P-2, for example, indicates low flow; P-4, greater flow, and so on. The number indicates minor adjustments in fuel flow. The first diagram shows the relationship between the alphanumeric needle jet size number and fuel flow.

NOTE: Needle jets carrying the numbers 166, 159 or 169 in addition to the P-2 or P-4 and are not interchangeable. Be sure correct needles are used as specified for your snowmobile.

Main Jet System

PRINCIPLES OF OPERATION

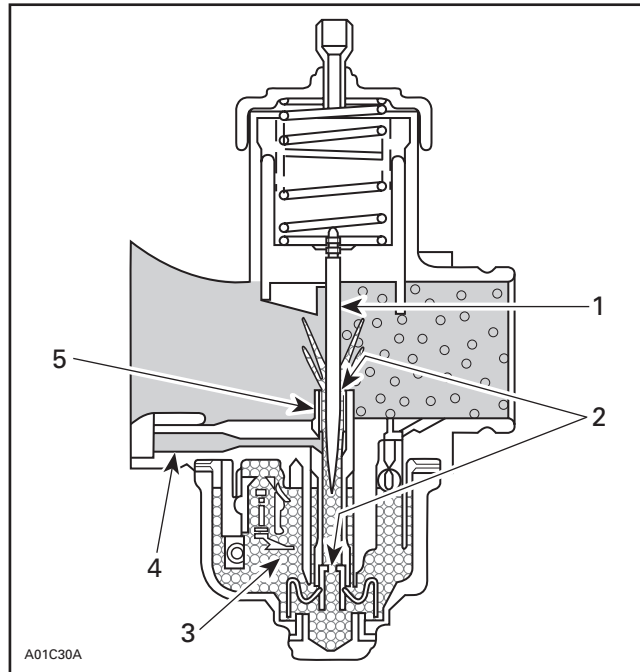

1. Jet needle
2. Metered here
3. Fuel
4. Air
5. Needle jet

The main jet system starts to function when the throttle is approximately 1/4 open. The mid range fuel is supplied by the main jet and regulated by the needle jet/jet needle combination. The main jet meters the fuel when the throttle is in the wide open position.

The main jets are available in sizes from number 50 to number 840. The size number corresponds to flow and not necessarily to hole size.

When experiencing erratic operation or overheating, check the main jet for dirt which can plug the orifice.

TUNING THE MAIN JET SYSTEM

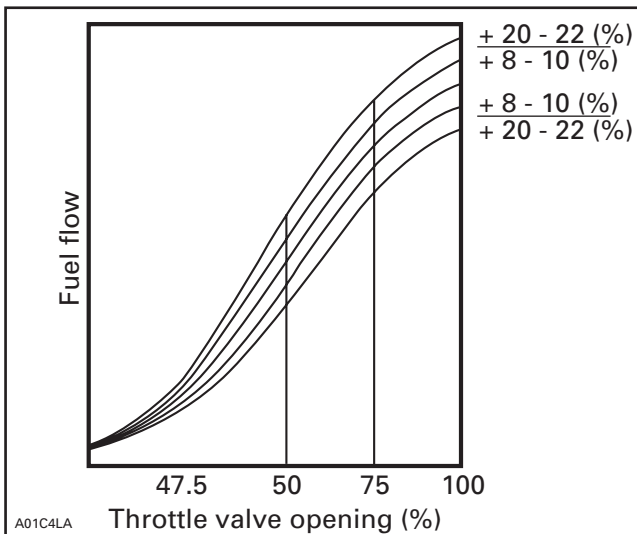

Before operating the snowmobile, make sure all parts, including clutch and drive belt, are in good operating condition.

1. Operate snowmobile at wide open throttle for several minutes on a flat, well packed surface. Change main jet if snowmobile fails to achieve maximum RPM or labors at high RPM.
2. Continue to operate at wide open throttle and shut off ignition before releasing throttle. Examine exhaust manifold and spark plugs to determine if fuel/air mixture is too lean.

NOTE: Do not change jet sizes by more than one increment (step) at a time.

3. If the exhaust manifold or spark plug insulator is dark brown or black, the fuel/air mixture is too rich. Decrease jet size.
4. If the exhaust manifold or spark plug insulator is very light in color, the fuel/air mixture is too lean. Increase jet size.
5. If you cannot determine the color, proceed as if fuel/air mixture were too lean and increase jet size. If operation improves, continue to increase jet size to obtain peak performance. If operation becomes worse, decrease jet size to obtain peak performance.
6. After proper main jet is selected, recheck jet needle and needle jet.

Troubleshooting

When the carburetor setting is not correct for the engine, various irregularities are noticed. These can be traced to two causes as a whole:

1. When the air/fuel mixture is too rich:
 - a. The engine noise is full and intermittent (four stroking).
 - b. The condition grows worse when the enricher is opened.
 - c. The condition grows worse when the engine gets hot.
 - d. Removal of the air cleaner will somewhat improve the condition.
 - e. Exhaust gases are heavy.
 - f. Spark plug is fouled.
2. When the air/fuel mixture is too lean:
 - a. The engine overheats.
 - b. The condition improves when the enricher is opened.
 - c. Acceleration is poor.
 - d. Spark plug electrodes are melted.
 - e. The revolution of the engine fluctuates and a lack of power is noticed.
 - f. Piston seizure or scuffing occurs.

SECTION 04 - ENGINE PREPARATION

Functional Range Effectiveness in Relation to Throttle Opening

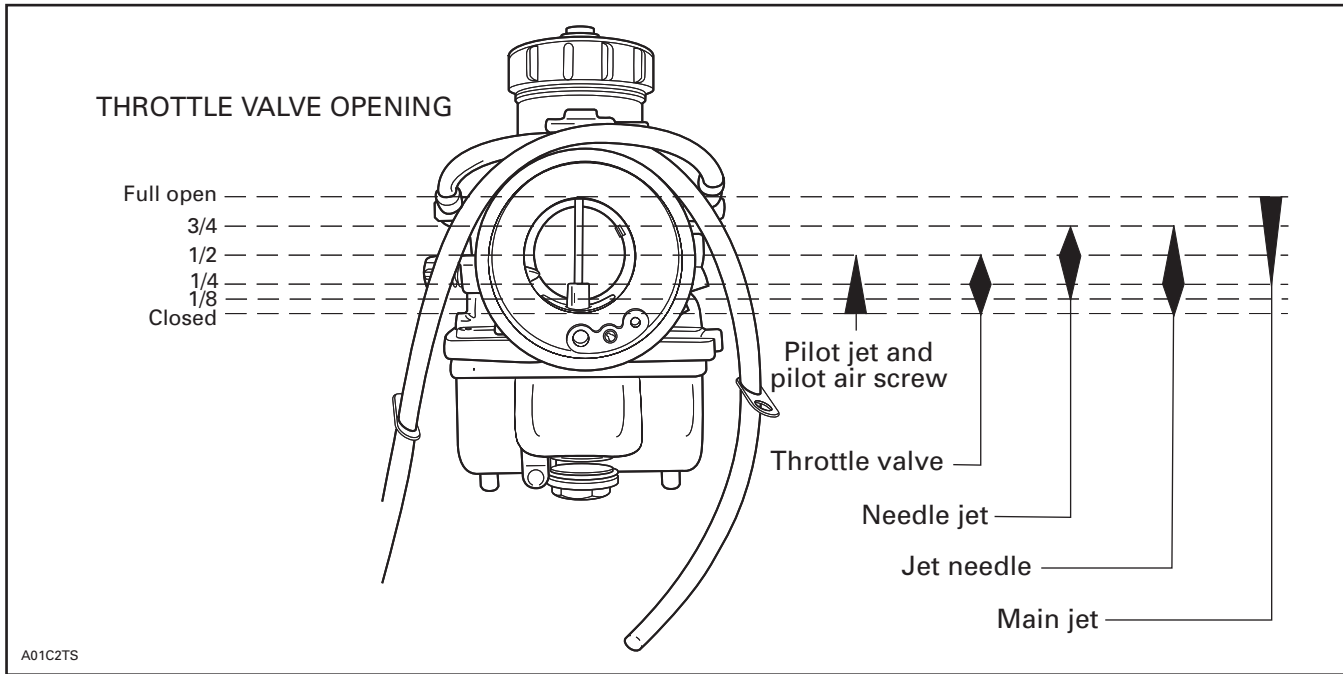

SECTION 04 - ENGINE PREPARATION

MIKUNI CARBURETOR (TMX)
MX Zx 440

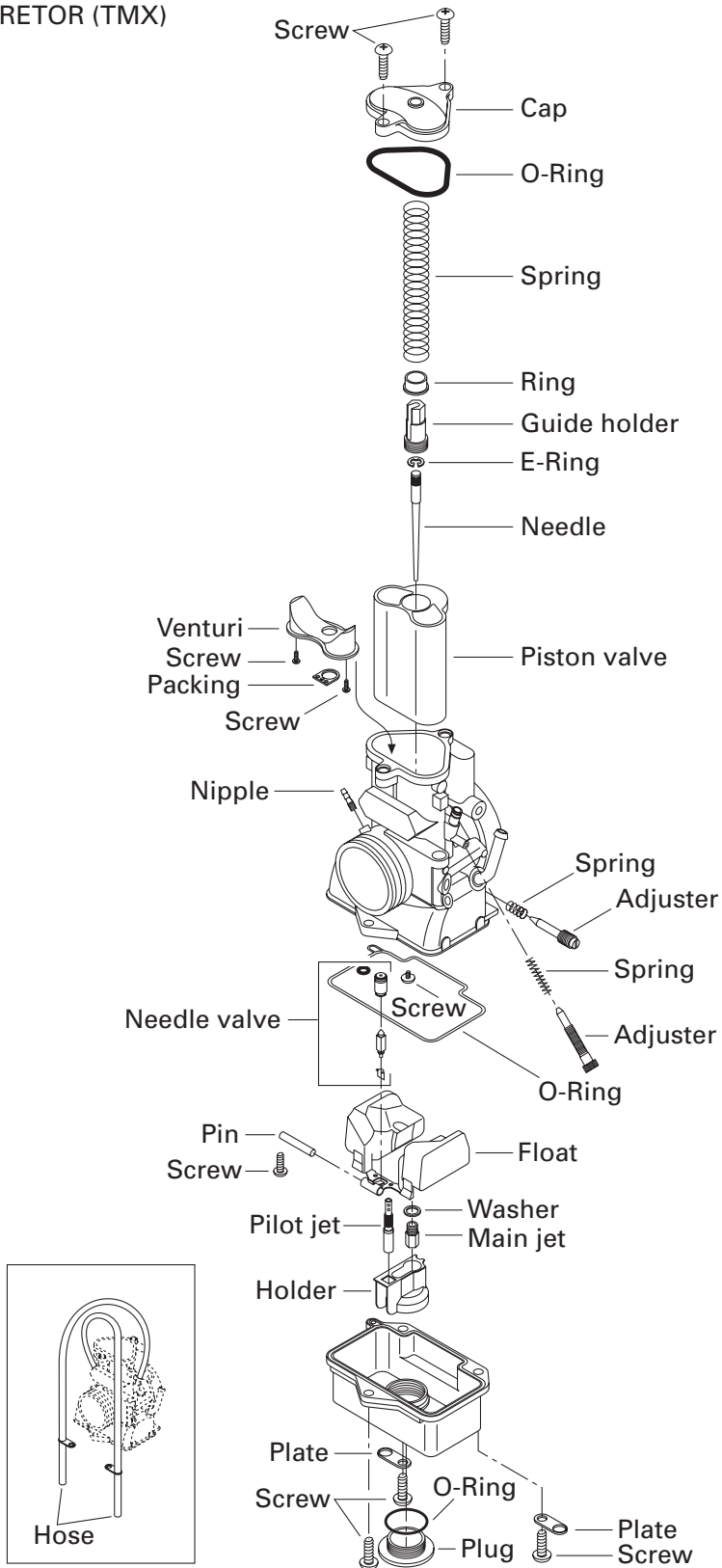

A32C34S

SECTION 04 - ENGINE PREPARATION

Mikuni TMX Carburetor (tuning parts)

P/N	DESCRIPTION
486 212 400	Pilot Jet, 15
486 212 500	Pilot Jet, 17.5
486 212 600	Pilot Jet, 20
486 212 700	Pilot Jet, 22.5
404 161 870	Pilot Jet, 25
486 212 800	Pilot Jet, 27.5
486 212 900	Pilot Jet, 30
486 213 000	Pilot Jet, 32.5
486 213 100	Pilot Jet, 35
404 144 700	Pilot Jet, 40
486 201 400	Pilot Jet, 45
404 144 800	Pilot Jet, 50
486 201 500	Pilot Jet, 55
404 145 300	Pilot Jet, 60
404 145 400	Pilot Jet, 65
486 213 200	Piston Valve, 3.0
486 213 300	Piston Valve, 3.5
404 161 867	Piston Valve, 4.0
486 213 400	Piston Valve, 4.5
486 213 500	Piston Valve, 5.0
404 161 868	Inlet Needle & Seat 1.5
404 161 871	Needle, J8-6FIY05-58
404 161 872	Needle, J8-6FIY04-59
404 161 873	Needle, J8-6FIY06-57

Part numbers with a 486 prefix must be ordered from Valcourt Race Dept. All others must be ordered from your local Ski-Doo dealer.

IGNITION SYSTEMS, SPARK PLUGS

Two-stroke engines in snowmobiles rely on an electric spark to initiate combustion of the fuel/air charge which has been inducted into the cylinder. For the engine to operate efficiently, the spark must be delivered at precisely the right moment in relation to the position of the piston in the cylinder and the rotational speed of the crankshaft.

Additionally, the spark must be of sufficient intensity to fire the fuel mixture, even at high compression pressure and high RPM.

It is the function of the ignition system to generate this voltage and provide it to the spark plug at the correct time.

The Nippondenso capacitor discharge ignition (CDI) system has magnets located on the crankshaft flywheel. AC voltage is induced in the generating coil(s) as the poles of the magnets rotate past the poles of the coils. Timing is controlled by a trigger coil or the position of the coil poles relative to the magnet poles, which are directly related to piston position. The CD (or amplifier) box contains the electronic circuitry to store and control the initial voltage and deliver it to the ignition coil (and then the spark plug) at the correct moment. The ignition coil is a transformer that steps up the relatively low voltage, 150-300 V, of the generating coil to the 20,400 – 40,000 volts necessary to jump the spark plug gap and initiate the burning of the fuel/air mixture in the combustion chamber.

Maximum power from a given engine configuration is produced when peak combustion chamber pressure (about 750 PSI) takes place at about 15° of crankshaft rotation ATDC. Normal combustion is the controlled burning of the air/fuel mixture in the cylinder. The flame is initiated at the spark plug and spreads to the unburned mixture at the edges of the cylinder.

This flame front travels through the cylinder at about 100 feet per second. In order to achieve maximum pressure at about 15° ATDC, the spark must occur about 15° before TDC. Complete combustion will finish at about 35° ATDC. The actual amount of spark advance BTDC is dependent upon bore size, combustion chamber shape, operating RPM, mixture turbulence and the actual flame speed.

Flame speed is directly proportional to piston speed in an almost linear fashion. Though it is not completely understood why this relationship exists, it is thought to be related to intake speed and mixture turbulence. Hence, flame speed increases as RPM increases. It also increases as the air/fuel ratio becomes leaner.

Because the flame speed is slower at lower RPM's, more advance at low RPM is necessary for maximum performance. Advancing the spark too much BTDC for the needs of the engine will cause the engine to go into detonation.

The optimum ignition would then have timing significantly advanced at lower RPM, but would retard the timing at higher RPM to keep the engine out of detonation. Generally, as the ignition timing is advanced, the low end mid range power will be improved and the peak power will be moved to a lower RPM. Retarding the timing will generally reduce low and mid range power but may allow jetting to be leaner and increase peak power. Peak power will be moved to a higher RPM. These are generalizations and ignition timing must be optimized depending on engine design, RPM range and operating conditions.

Ignition advance on Rotax engines is measured by a linear distance of piston travel BTDC. A dimension taken through a straight spark plug hole in the center of the head is a direct measurement. A dimension through an angled plug hole on one side of the head is an indirect measurement. A direct measurement can be converted to degrees of crankshaft rotation by the appropriate formulas. Initial ignition timing procedures can be found in the *Shop Manual* for the particular model being worked on.

Ignition Timing

Ignition timing is no longer able to be adjusted mechanically. It must be done by your dealer with an MPEM programmer.

Spark Plug Heat Range

Spark plug heat ranges are selected by measuring actual combustion chamber temperatures. A colder spark plug, one that dissipates heat more rapidly, is often required when engines are modified to produce more horsepower.

The proper operating temperature or heat range of the spark plugs is determined by the spark plugs ability to dissipate the heat generated by combustion.

The longer the heat path between the electrode tip to the plug shell, the higher the spark plug operating temperature will be — and inversely, the shorter the heat path, the lower the operating temperature will be.

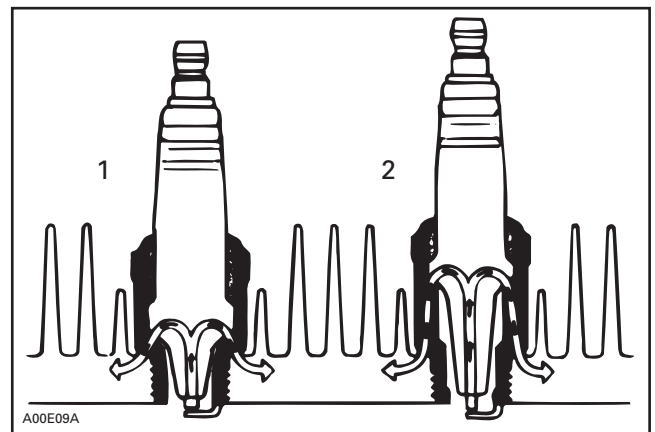

1. Cold
2. Hot

A cold type plug has a relatively short insulator nose and transfers heat very rapidly into the cylinder head.

Such a plug is used in heavy duty or continuous high speed operation to avoid overheating.

The hot type plug has a longer insulator nose and transfers heat more slowly away from its firing end. It runs hotter and burns off combustion deposits which might tend to foul the plug during prolonged idle or low speed operation.

Generally speaking, if you have increased horsepower by 10-15%, you will have to change to the next colder heat range spark plug.

Most Ski-Doo's are equipped stock with NGK BR-9ES spark plugs. These are resistor-type plugs which help reduce radio frequency interference.

To help prevent spark plug fouling use BR9ECS type plug. Used **ONLY** resistor type plugs.

SECTION 04 - ENGINE PREPARATION

Design Symbols Used on NGK Spark Plugs

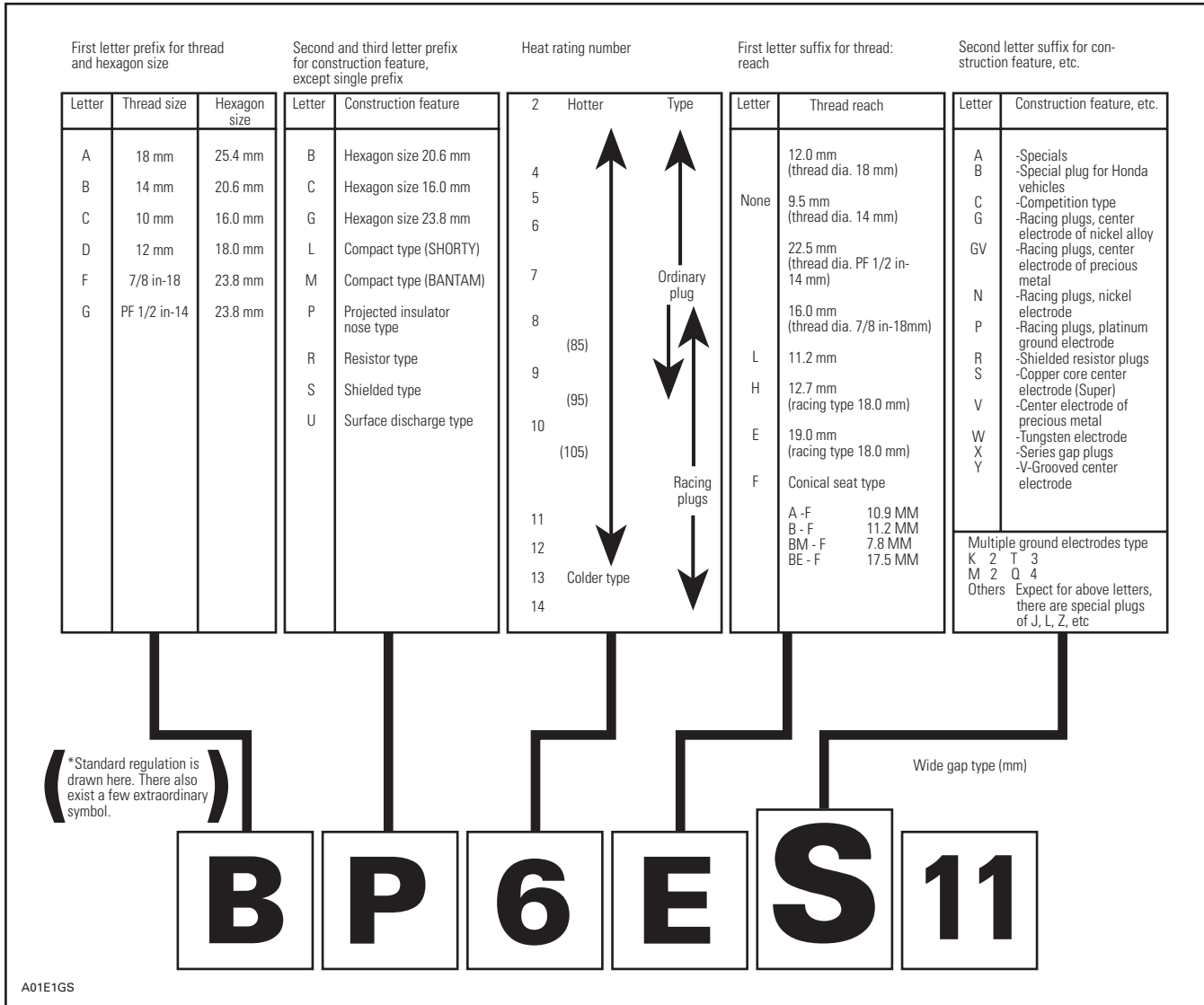

493, 593, 693, AND 793 ENGINE TYPES

ZX Series

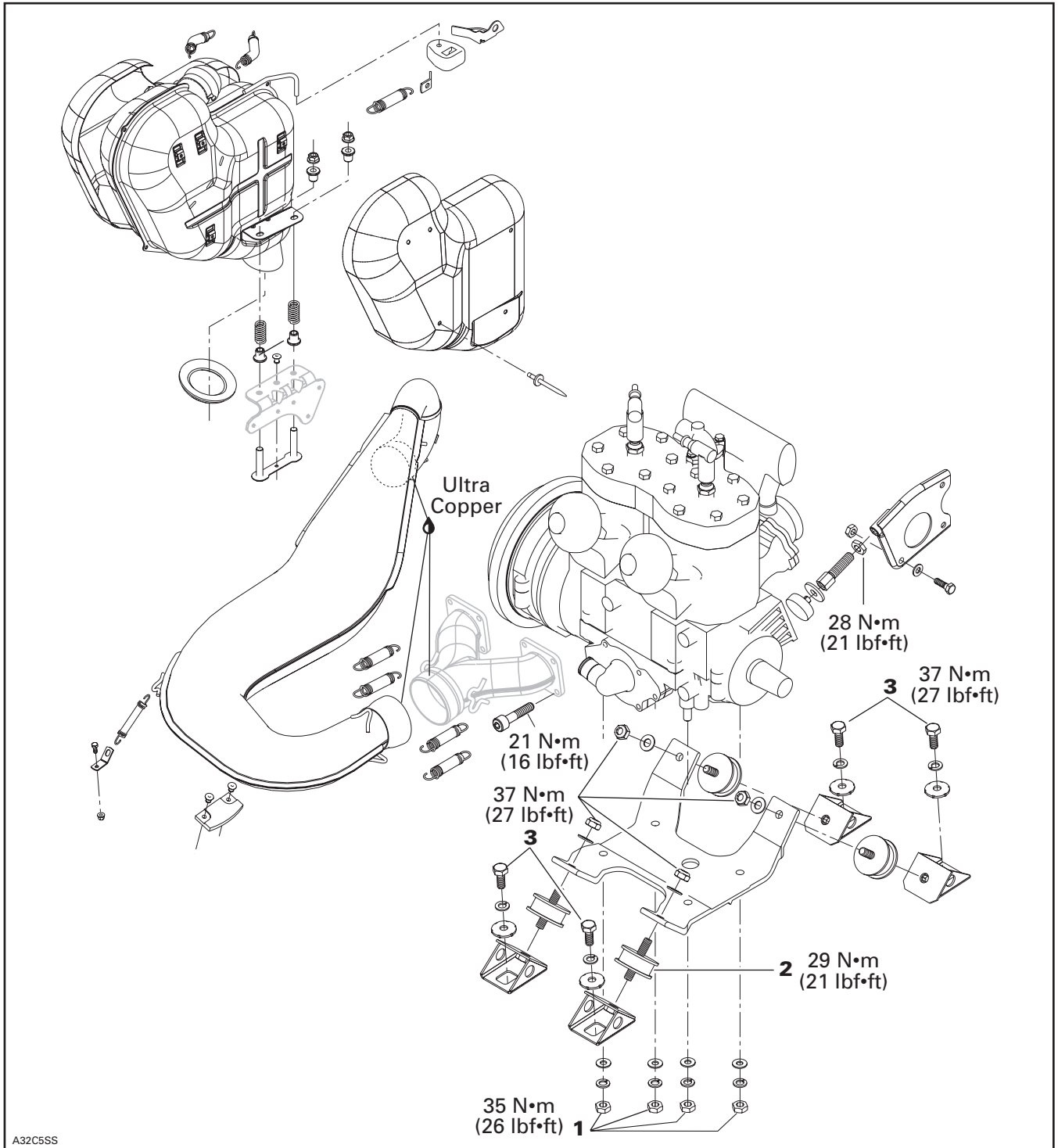

TYPICAL

SECTION 04 - ENGINE PREPARATION

MAINTENANCE

Tuned pipe gear clamps must be retightened to 3.5 N•m (31 lbf•in) after the first 10 hours of use, then every 3200 km (2000 m.).

CAUTION: Do not over tighten.

NOTE: Replace with new ones any damaged gear clamps. Refer to appropriate *Parts Catalogs* to order new gear clamps.

REMOVAL FROM VEHICLE

Open hood.

Remove tuned pipe and muffler.

Drain engine coolant.

Remove or unplug the following then lift off engine from engine compartment.

NOTE: Use of a hoist is recommended.

- guard
- air silencer
- drive belt
- rewind starter handle
- drive pulley (not necessary if engine has not to be disassemble)
- hood, refer to BODY
- carburetors
- impulse hose and electrical connectors
- oil injection inlet line at oil injection pump, install hose pincher
- oil pump cable
- coolant hoses between cylinder head and radiator
- coolant by-pass hose
- coolant hose at front of coolant reservoir
- engine support screws
- engine stopper (left rear of engine).

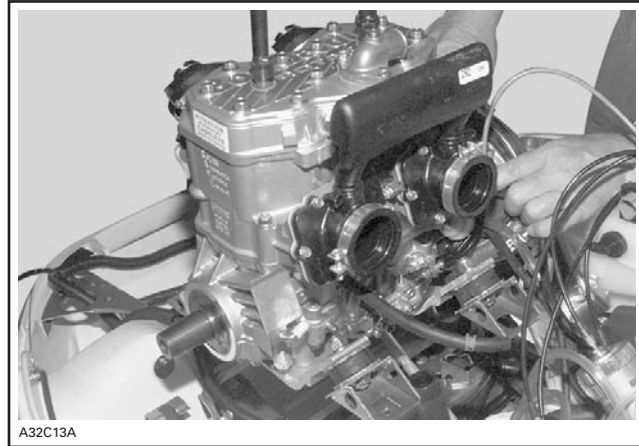

TYPICAL — ENGINE REMOVAL

1,2,3,4, Engine Support Nut and Manifold Screw

Torque the engine/support nuts **no. 1** to 35 N•m (26 lbf•ft).

Torque rubber mounts **no. 2** to support bracket to 29 N•m (21 lbf•ft).

Torque rubber mount/support nuts to 37 N•m (27 lbf•ft).

Torque support brackets/chassis screws **no. 3** to 37 N•m (27 lbf•ft).

Torque manifold screws **no. 4** to:

M6 = 10 N•m (89 lbf•in)

M8 = 23 N•m (17 lbf•ft)

INSTALLATION ON VEHICLE

To install engine on vehicle, reverse removal procedure. However, pay attention, to all appropriate component/system reinstallation procedures described throughout this *Shop Manual* and to the following:

- After throttle cable installation, check carburetor maximum throttle opening and oil injection pump adjustment.
- Check pulley alignment and drive belt tension.
- Seal exhaust ball joints with Ultra Copper (P/N 293 800 090).

TOP END

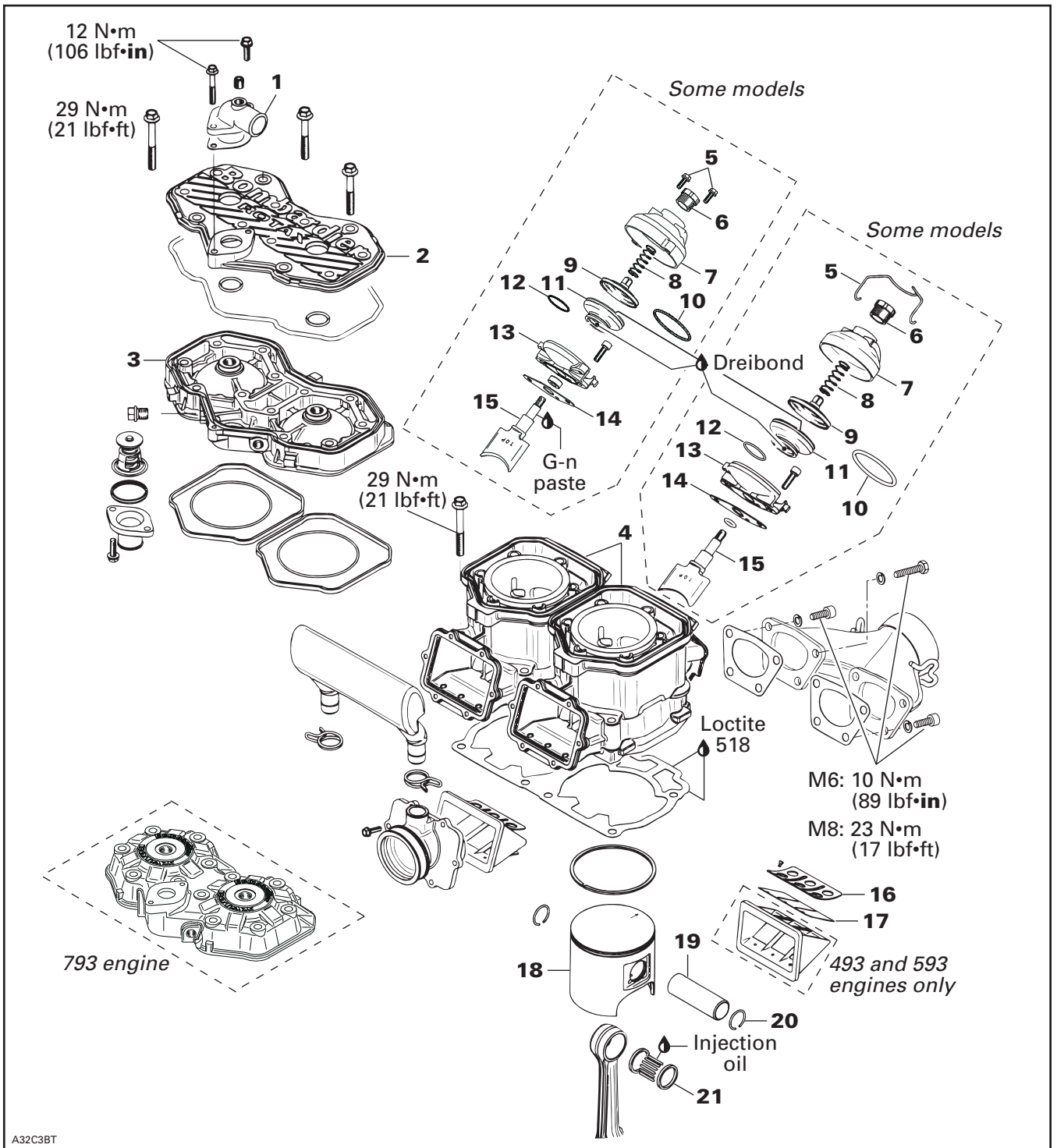

A32C3BT

SECTION 04 - ENGINE PREPARATION

TROUBLESHOOTING

Before completely disassemble engine, check air-tightness. Refer to LEAK TEST AND ENGINE DIMENSION MEASUREMENT.

NOTE: The following procedures can be done without removing the engine from chassis.

COMPONENT REMOVAL WITH THE ENGINE INSTALLED

Most engine components can be removed with engine on vehicle such as:

- cylinder head
- cylinder head cover
- piston(s)
- piston ring(s)
- cylinder(s)
- rewind starter
- oil pump
- water pump
- magneto flywheel
- RAVE valve(s)
- reed valve(s).

CLEANING

Discard all gaskets and O-rings.

Clean all metal components in a non-ferrous metal cleaner.

Scrape off carbon formation from cylinder exhaust port cylinder head and piston dome using a wooden spatula.

NOTE: The letters "AUS" (over an arrow on the piston dome) must be visible after cleaning.

Clean the piston ring groove with a groove cleaner tool or with a piece of broken ring.

DISASSEMBLY

RAVE System

NOTE: RAVE stands for Rotax Adjustable Variable Exhaust.

Remove spring clip or screws **no. 5**, cover **no. 7** and spring **no. 8**.

Remove spring **no. 10**.

Unscrew valve piston **no. 9**.

Remove bellows **no. 11** and spring **no. 12**.

Remove cylindrical screws. Remove valve housing **no. 13**.

Pull out exhaust valve **no. 15**.



RAVE VALVE PARTIALLY REMOVED

2, Cylinder

Remove spark plugs, coolant outlet **no. 30**. Unscrew cylinder head cover **no. 2** then cylinder head **no. 3**.

18, Piston

Place a clean cloth or rubber pad (P/N 529 023 400) over crankcase. Then with a pointed tool inserted in piston notch, remove both circlips **no. 20** from piston **no. 18**.

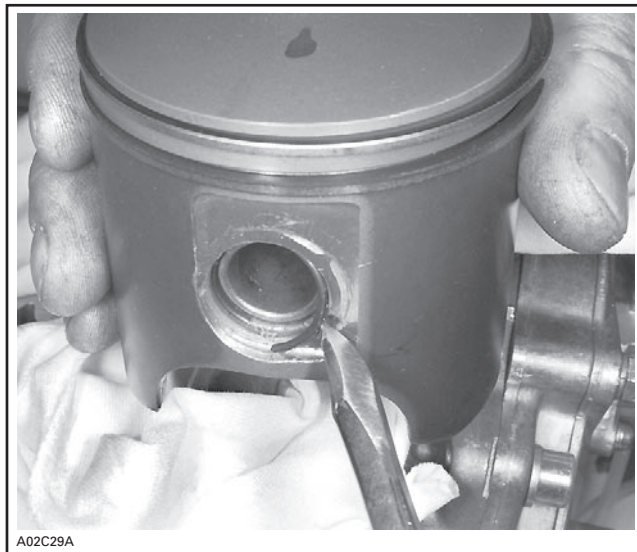

TYPICAL

SECTION 04 - ENGINE PREPARATION

All engines are equipped with cageless piston pin bearings.

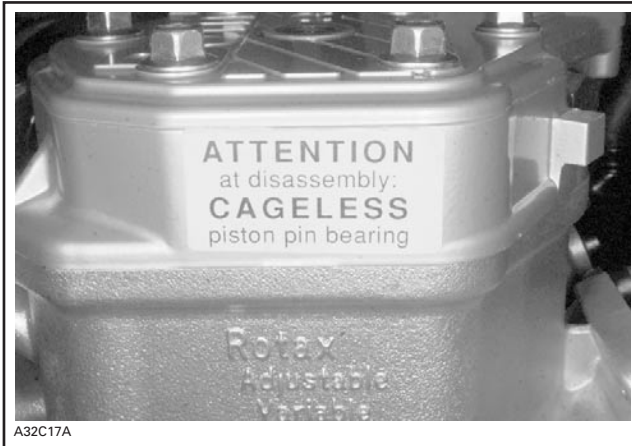

Use piston pin puller (P/N 529 035 503) along with 18 mm sleeve kit (P/N 529 035 041) for 493 engine and 20 mm sleeve kit (P/N 529 035 542) for 593, 693 and 793 engines. Use also a locating sleeve.

NOTE: The locating sleeve is the same that contains new cageless bearing.

Insert piston pin puller (P/N 529 035 503) making sure it sits squarely against piston.

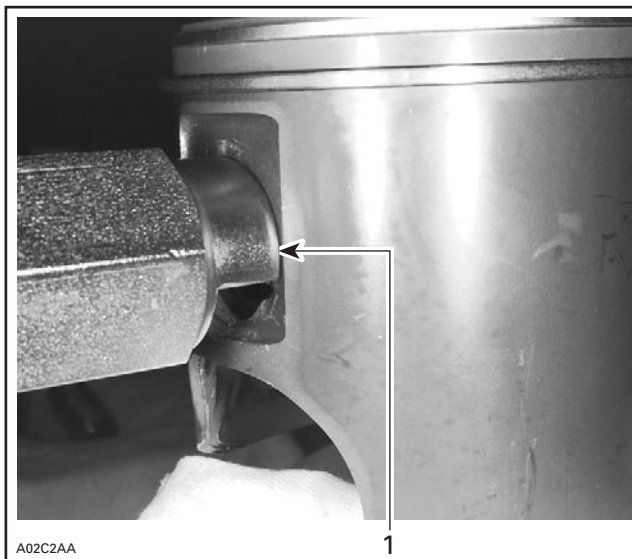

TYPICAL

1. Properly seated all around

Install sleeve then shouldered sleeve over puller rod.

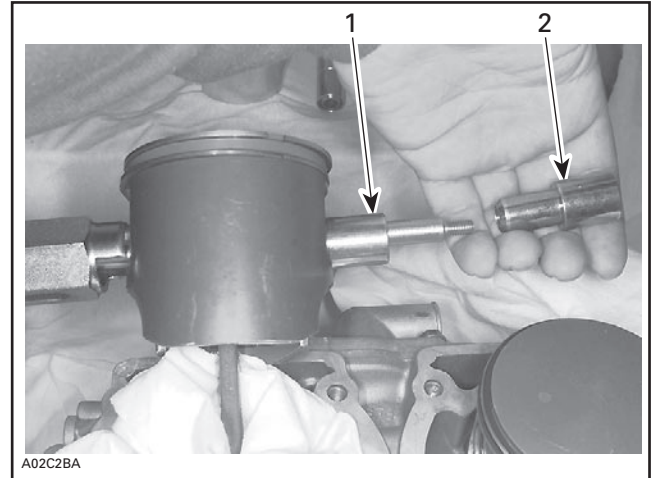

TYPICAL — INSTALLATION OF SLEEVE KIT

1. Sleeve
2. Shouldered sleeve

Screw (LH threads) extracting nut.

Pull out piston pin **no. 19** by unscrewing puller until shouldered sleeve end is flush with thrust washer of piston pin bearing.



TYPICAL — PISTON PIN EXTRACTION

SECTION 04 - ENGINE PREPARATION

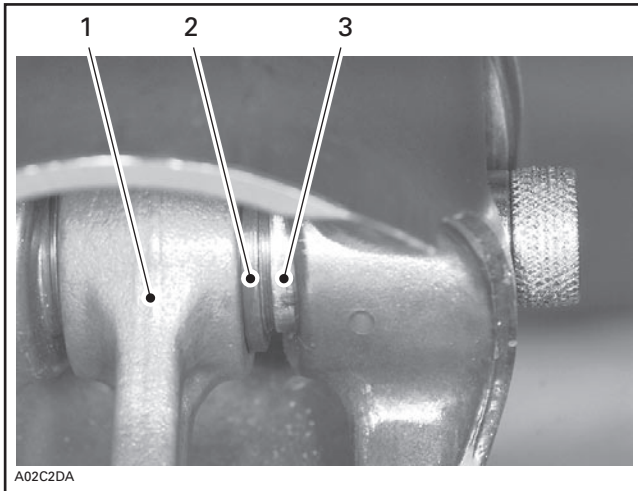

TYPICAL

1. Sleeve inside bearing
2. Thrust washer
3. Shouldered sleeve end

Remove puller. Pull out shouldered sleeve carefully.

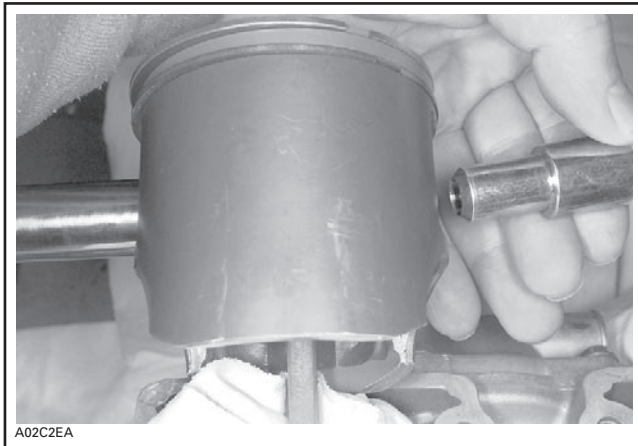

TYPICAL

Remove piston from connecting rod.
Install locating sleeve. Then push needle bearings along with thrust washers and sleeve.

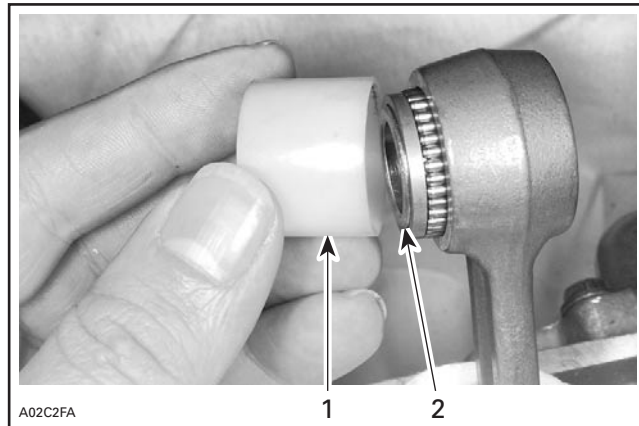

TYPICAL

1. Locating sleeve
2. Sleeve

INSPECTION

NOTE: Refer to LEAK TEST AND ENGINE DIMENSIONS MEASUREMENT.

RAVE System

Check valve rod housing and cylinder for clogged passages.

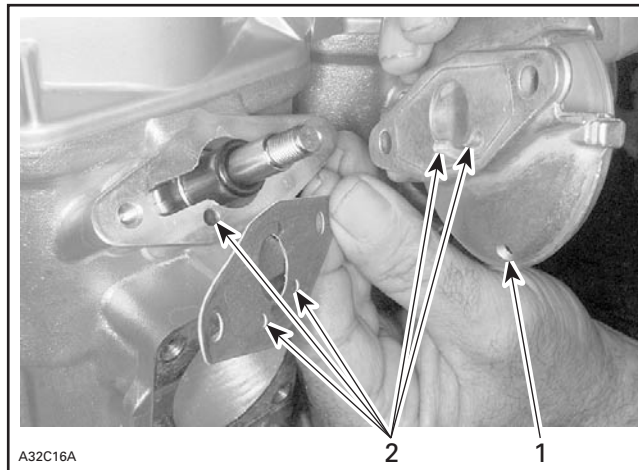

1. Draining hole
2. Passages

NOTE: Oil dripping from draining hole indicates a loosen spring or damaged bellows.

11, Bellows

Check for cracked, dried or perforated bellows.

8, Spring

ENGINE TYPE	SPRING P/N	WIRE DIA. MM (IN)	FREE LENGTH MM (IN)	PRELOAD IN N (LBF) AT COMPRESSED LENGTH OF 14 mm (.551 in)
493	420 239 948	1.0 (.039)	38.0 (1.50)	19.5 (4.37)
593 and 693	420 239 944	0.9 (.035)	48.5 (1.91)	15.9 (3.56)
793 on all Summit	420 239 942	0.8 (.031)	42.5 (1.67)	7.3 (1.64)
793 on all MX Z	420 239 941	0.8 (.031)	52.5 (2.07)	10.5 (2.36)

ASSEMBLY

RAVE System

Install RAVE valve with its mention top as illustrated in the removal photo. Tighten red cap **no. 6** screw to bottom.

4,18, Cylinder and Piston

493 and 593 Engines Only

Be sure to restore the chamfer around all cylinder sleeve port openings.

All Engines

Before inserting piston in cylinder, lubricate the cylinder with new injection oil or equivalent.

2,3,4, Cylinder Head Cover, Cylinder Head and Cylinder

Check flatness of part sealing surfaces. Refer to LEAK TEST AND ENGINE DIMENSION MEASUREMENT and look for **Checking Surface Flatness**.

When installing a new cageless bearing, replace half plastic cages with sleeve.

NOTE: 493 engine cageless bearings have 31 needles. 593, 693 and 793 engine cageless bearings have 28 needles.

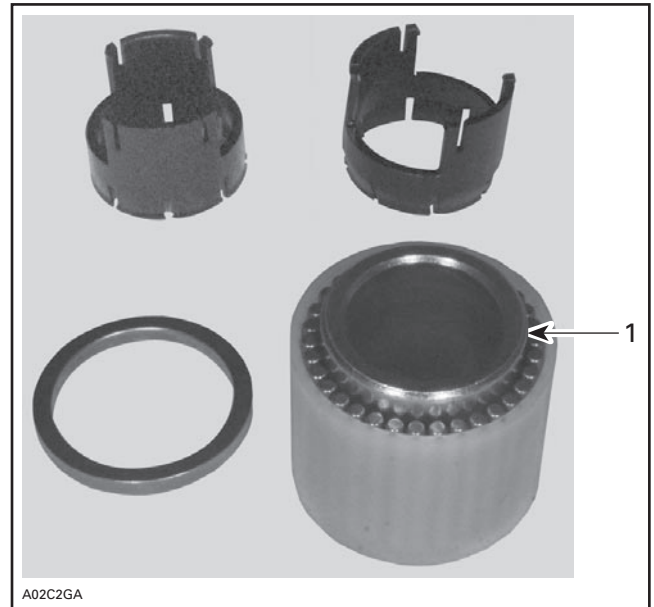

TYPICAL

1. Sleeve

Oil needle bearing with injection oil. Grease thrust washers and install them on each end of needles. Insert cageless bearing into connecting rod.



TYPICAL — CAGELESS BEARING AND SLEEVE INSTALLED

Heat piston with a 100 W lamp or a heat gun before piston installation.

CAUTION: Piston temperature must not exceed 46°C (115°F). Never use direct flame to heat the piston and never freeze the pin.

SECTION 04 - ENGINE PREPARATION

At assembly, place the pistons over the connecting rods with the letters "AUS" (over an arrow on the piston dome) facing in direction of the exhaust port.

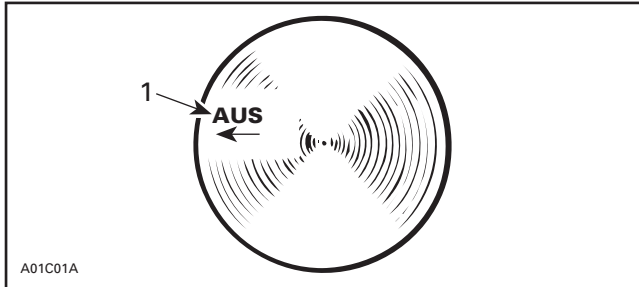

1. Exhaust

Install shouldered sleeve.



TYPICAL — SHOULDERED SLEEVE INSTALLATION

Install piston pin puller and turn handle until piston pin is correctly positioned in piston.

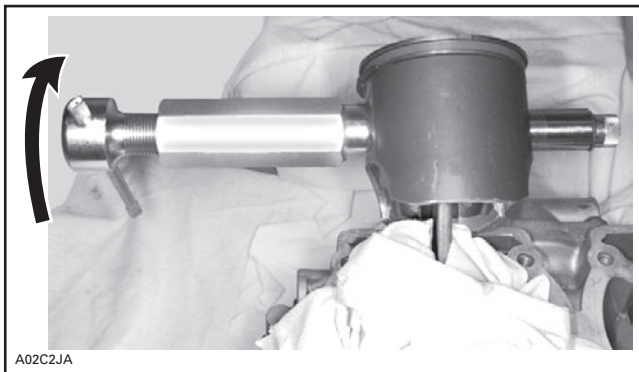

TYPICAL

All Models

CAUTION: Always install new circlips.

To minimize the effect of acceleration forces on circlip, install each circlip so the circlip break is at 6 o'clock as illustrated. Use appropriate piston circlip installer.

ENGINE TYPE	PISTON CIRCLIP INSTALLER (P/N)
493	529 035 561
593, 693 and 793	529 035 686

493 Engine

Insert circlip in tool at an angle.

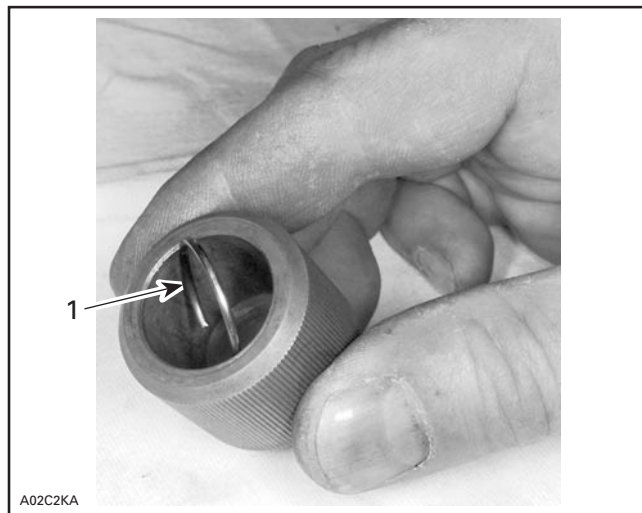

TYPICAL

1. Circlip

SECTION 04 - ENGINE PREPARATION

Square it up using a finger.

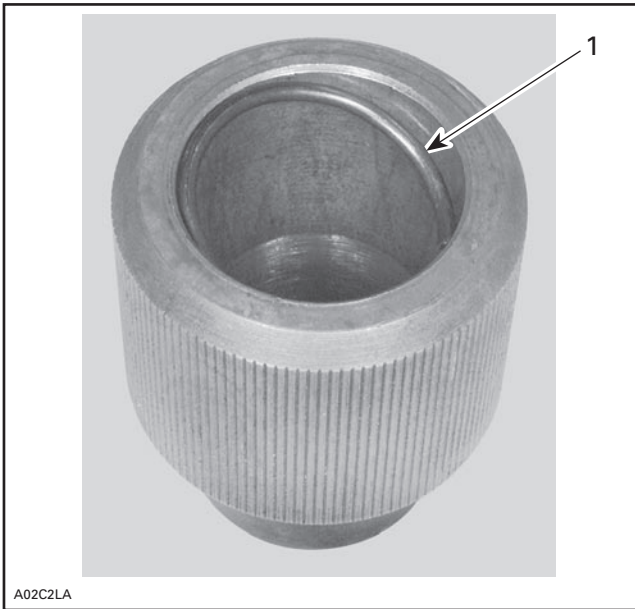

TYPICAL

1. Circlip

Continue to square it up using round end of circlip installer.

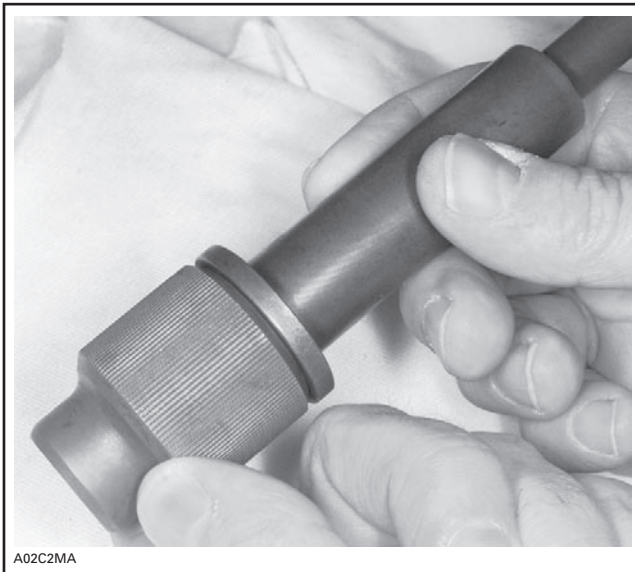

TYPICAL

Using square end of tool, push circlip in until it rests in groove.

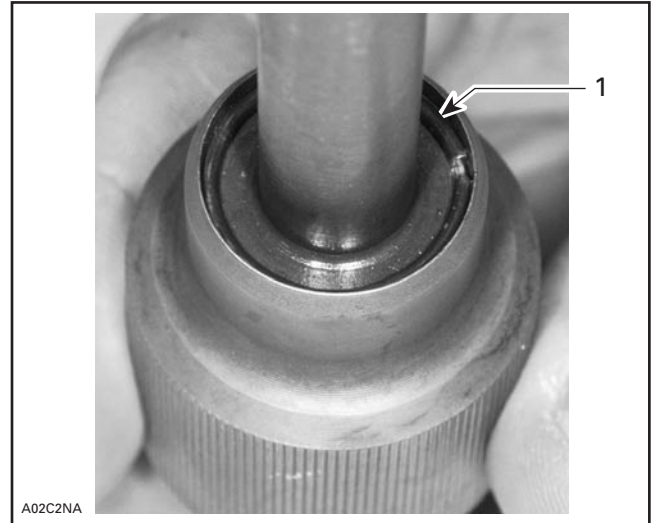

TYPICAL

1. Circlip in groove

Mount tool in piston making sure that circlip break is facing down.

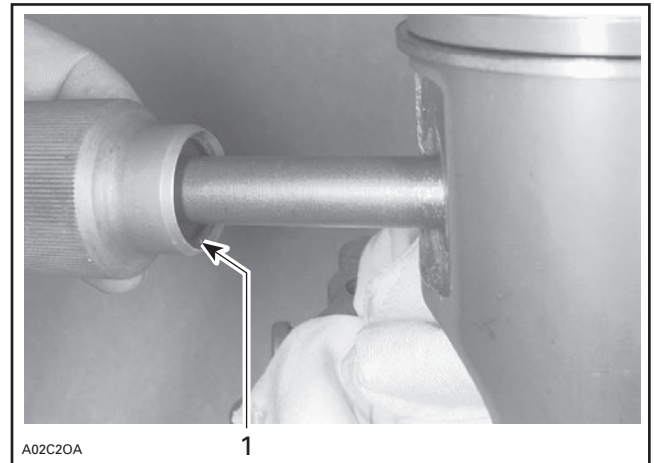

TYPICAL

1. Circlip break facing down

SECTION 04 - ENGINE PREPARATION

Hold tool firmly against piston then strike on round end of tool. Circlip will move from tool groove to piston groove.



A02C2PA

TYPICAL

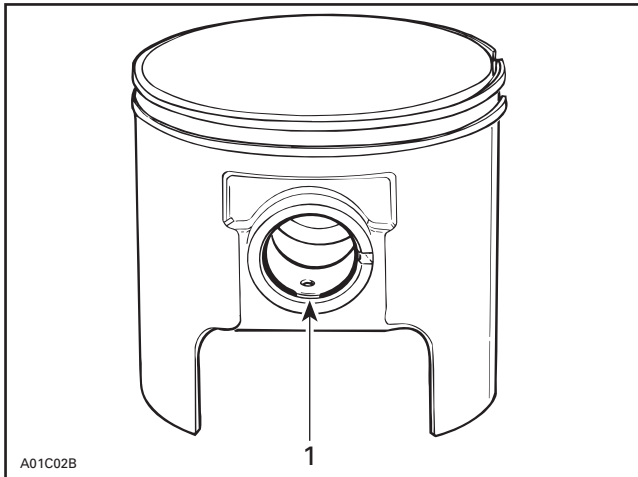

A01C02B

TYPICAL

1. Circlip break

593, 693 and 793 Engines

Use circlip installer (P/N 529 035 686) to install new mono-hook circlips no. 20.

Insert circlip into support in such a way that when installed in piston groove, the tab will face upward.



A32B0AA

With round end of pusher, position circlip perpendicular to the support axis.

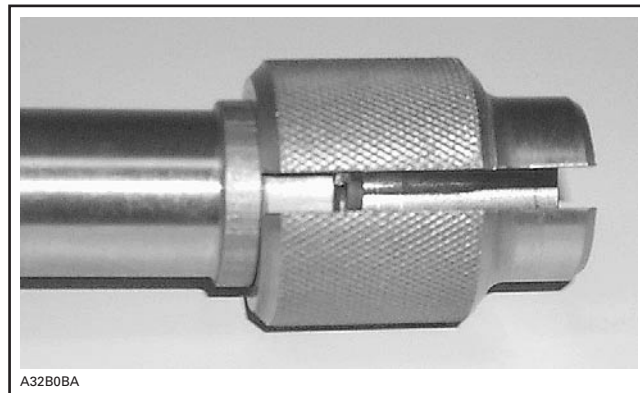

A32B0BA

With the other end of the pusher, push circlip into the support groove.

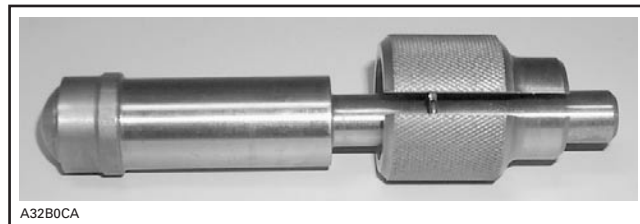

A32B0CA

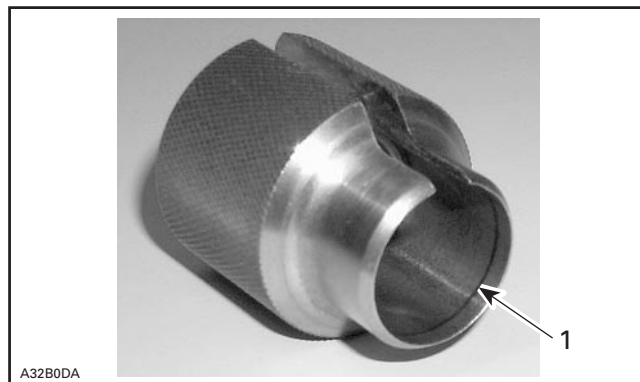

A32B0DA

1. Groove

SECTION 04 - ENGINE PREPARATION



CIRCLIP READY TO BE INSTALLED ON PISTON

Using a plastic hammer, tap pusher to insert circlip in place. Take care to install new circlips with tab toward top as per following photo.

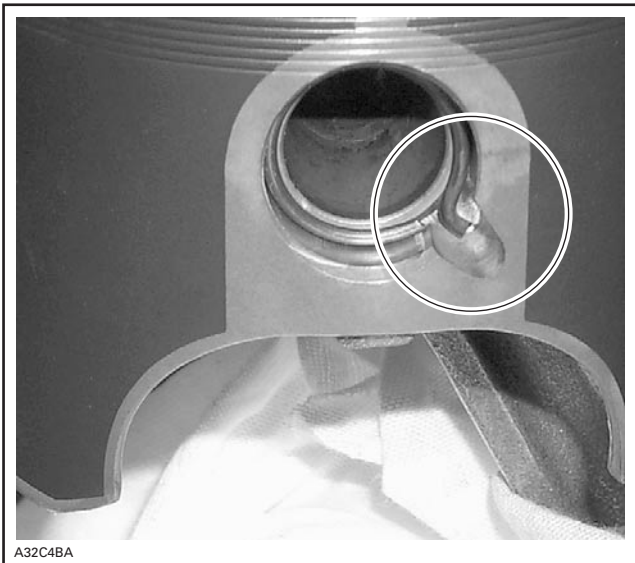

TAB TOWARD TOP

CAUTION: Always install new mono-hook circlips. If circlip installation fails at the first attempt, always retry with a new one as on a second attempt circlip will lose its normal retaining capabilities.

All Engines

CAUTION: Circlips must not move freely after installation; if so, replace them.

Clean cylinders and crankcase mating surfaces with Loctite Chisel (P/N 413 708 500).

Coat crankcase mating surface with Loctite 518 (P/N 293 800 038). Choose the right gasket thickness according to combustion chamber volume. Refer to LEAK TEST AND ENGINE DIMENSION MEASUREMENT. Install it on crankcase. Coat gasket with Loctite 518.

CAUTION: Always install a gasket of the proper thickness. Failure to do so may cause detonation and severe engine damage.

Before inserting piston in cylinder, lubricate the cylinder with new injection oil or equivalent.

Install cylinders. Do not tighten.

Install new rubber ring and round O-rings on each cylinder.

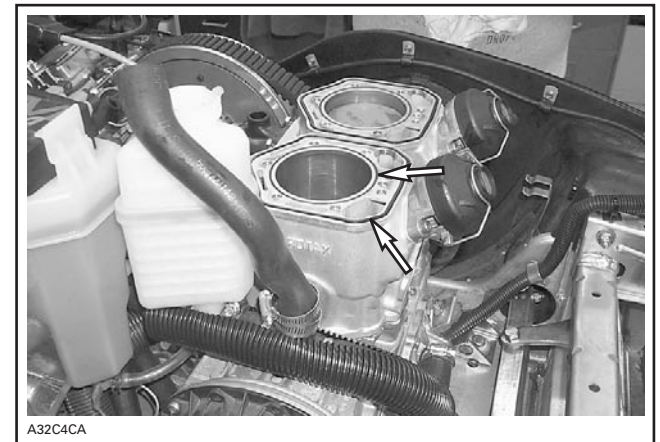

TYPICAL

NOTE: Carefully clean screws before reinstallation, specifically under screw head.

Install exhaust manifold with gaskets. Do not tighten yet.

At assembly, torque cylinder head screws to 29 N•m (21 lbf•ft) in the following illustrated sequence.

SECTION 04 - ENGINE PREPARATION

Tighten exhaust manifold bolts to 23 N•m (17 lbf•ft) in a criss-cross sequence.

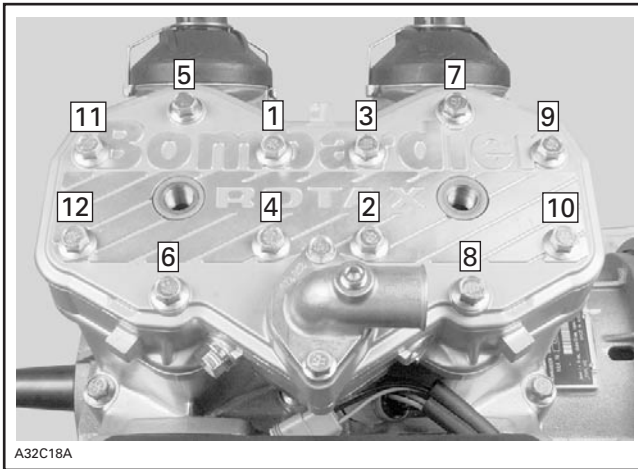

TYPICAL

Apply Loctite 243 (P/N 293 800 060) on screws threads. Install outlet socket and tighten screws to 12 N•m (106 lbf•in). Note position of longer screw.

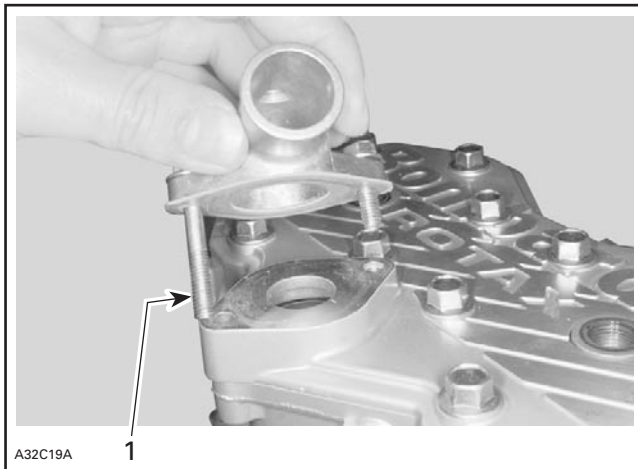

1. Longer screw

17, Reed Valve

Blades have a curved shape. Install with their curve facing reed block.

With blade stopper no. 16 removed, check reed valve for proper tightness. There must be no play between blade and valve body when exerting a finger pressure on blade at blade stopper location.

In case of a play, turn blade upside down and re-check. If there is still a play, replace blade and/or valve body.

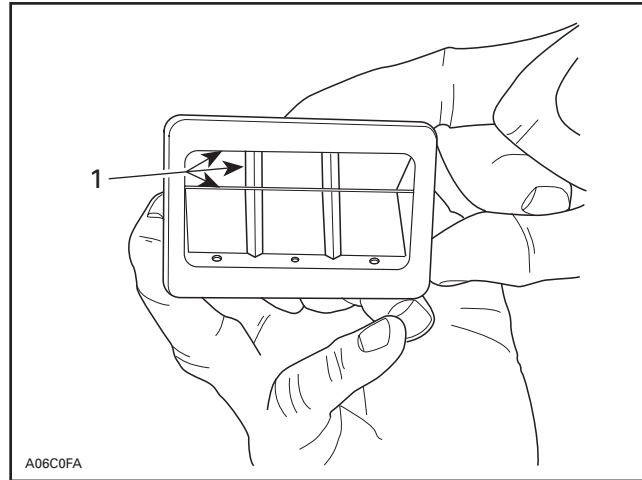

1. No play

Check distance from blade stopper outer edge and distance from center of reed valve block.

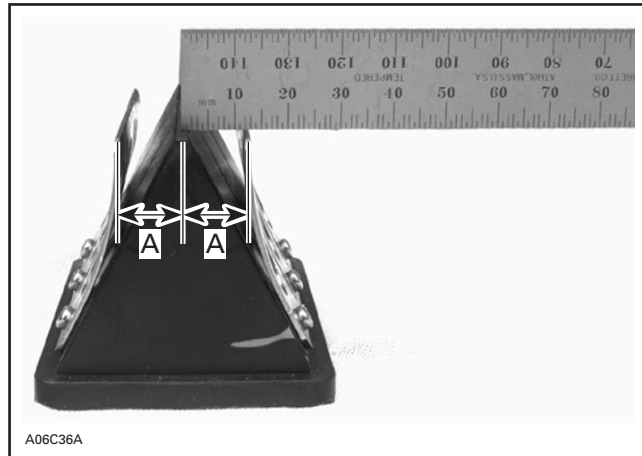

TYPICAL

A. 17.0 - 0, + 0.75 mm (.669 - 0, + .030 in)

Bent blade stopper as required to obtain the proper distance.

Blade stoppers may slightly interfere with cylinder during installation. Adjusted distance will be reduced automatically upon installation.

BOTTOM END

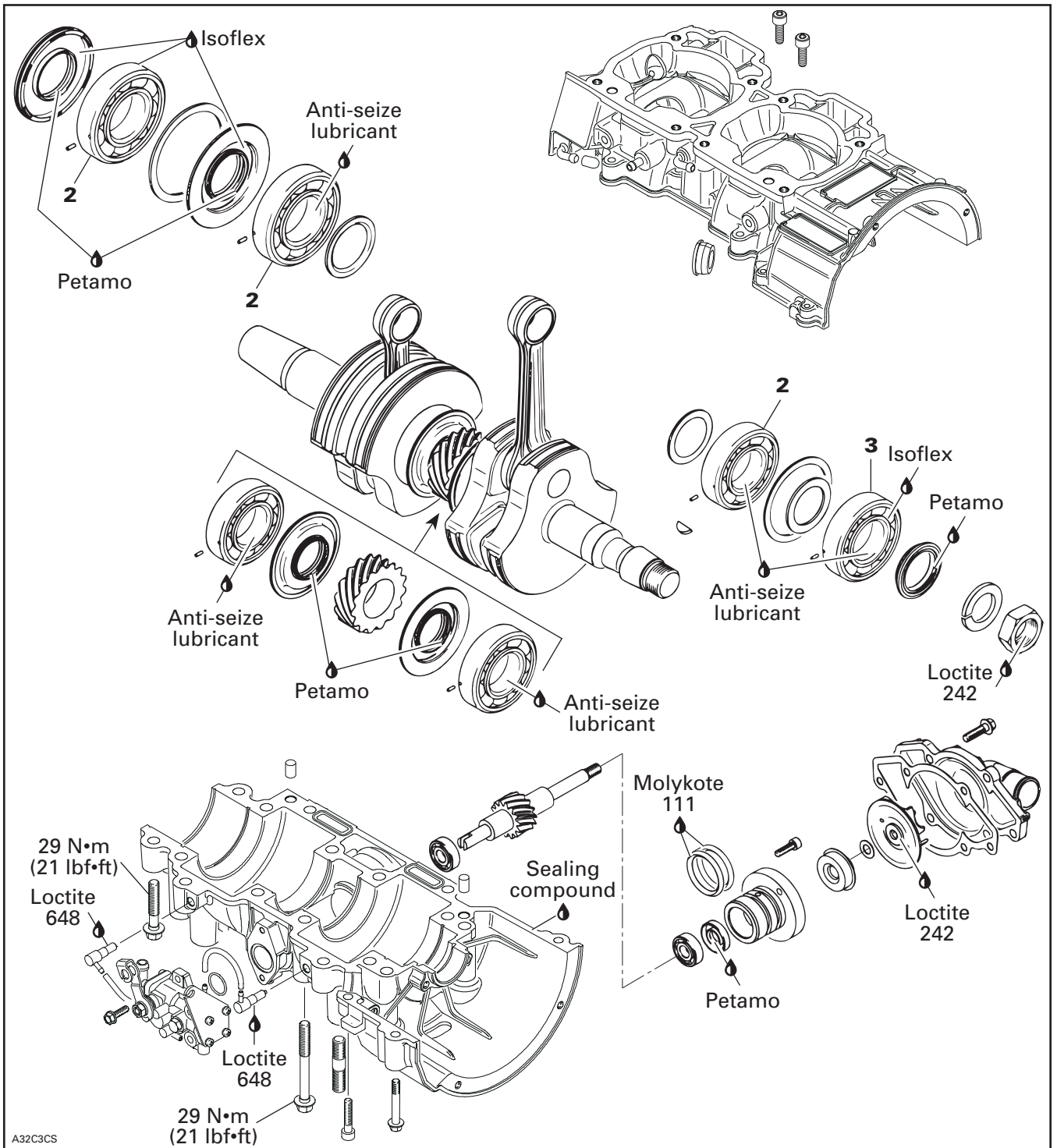

SECTION 04 - ENGINE PREPARATION

NOTE: Engine must be removed from chassis to perform the following procedures.

CLEANING

Discard all oil seals, gaskets, O-rings and sealing rings.

Clean all metal components in a non-ferrous metal cleaner. Use Gasket remover (P/N 413 708 500) accordingly.

Remove old paste gasket from crankcase mating surfaces with Gasket remover (P/N 413 708 500).

CAUTION: Never use a sharp object to scrape away old sealant as score marks incurred are detrimental to crankcase sealing.

DISASSEMBLY

General

To remove drive pulley, refer to DRIVE PULLEY.

To remove magneto, refer to CDI SYSTEM.

2,3, Crankshaft Bearing

To remove bearings from crankshaft, use a protective cap and special puller, as illustrated.

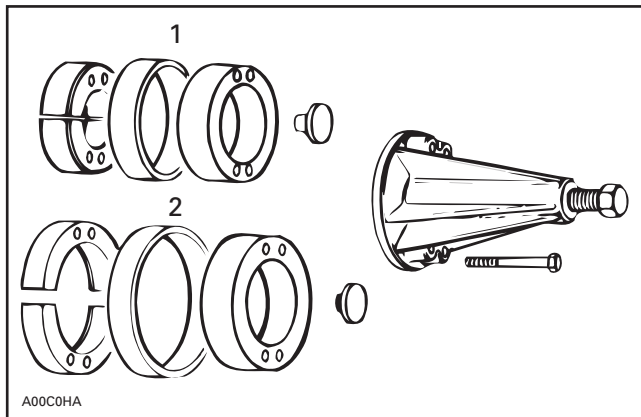

1. PTO side
2. MAG side

INSPECTION

NOTE: Refer to LEAK TEST AND ENGINE DIMENSIONS MEASUREMENT.

ASSEMBLY

Coat lip of all seals with Petamo grease (P/N 420 899 271).

2, Crankshaft Bearing

Smear anti-seize lubricant (P/N 413 701 000) on part of crankshaft where bearing fits.

Prior to installation, place bearings into an oil container filled with injection oil previously heated to 75°C (167°F). This will expand bearing and ease installation.

Some bearings must be lubricated with Isoflex grease (P/N 293 550 021).

CAUTION: Use only the recommended Isoflex grease. Make sure not to push Isoflex grease between outside bearing race and half crankcase.

NOTE: The 50 g tube corresponds to 50 cc of grease.

Put 45 to 50 mL of grease in a syringe.

Fill PTO side inner seal with Isoflex grease (about 10 mL).

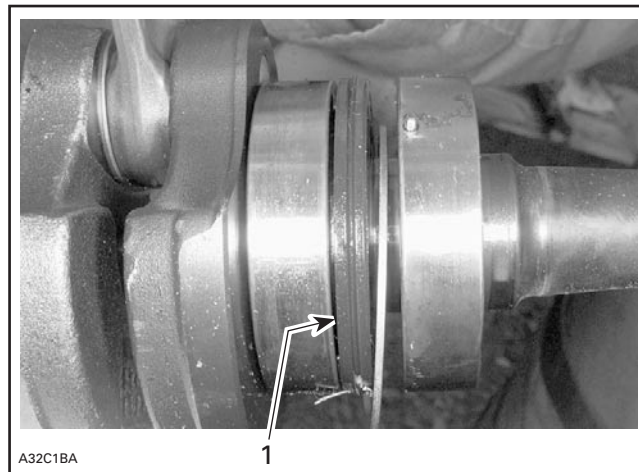

TYPICAL

1. PTO side inner seal filled with Isoflex grease

Put 35 to 40 mL of grease in a syringe.

With the syringe, fill the outer ball bearing with grease.

SECTION 04 - ENGINE PREPARATION



BALLS COATED WITH A SEAM OF GREASE

Coat inner side of outer seal (about 35 mL for 493 and 593 engine types and 40 mL for 693 and 793 engine types) and set it in place.

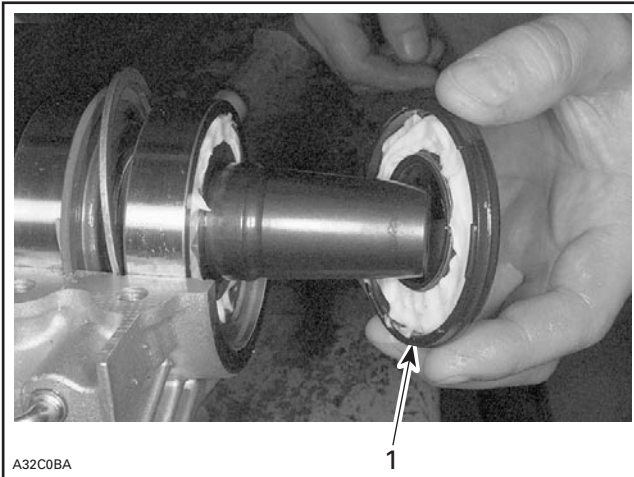

1. Fill with grease and set in place

Use the remaining grease to coat the inner side of the ball bearing.

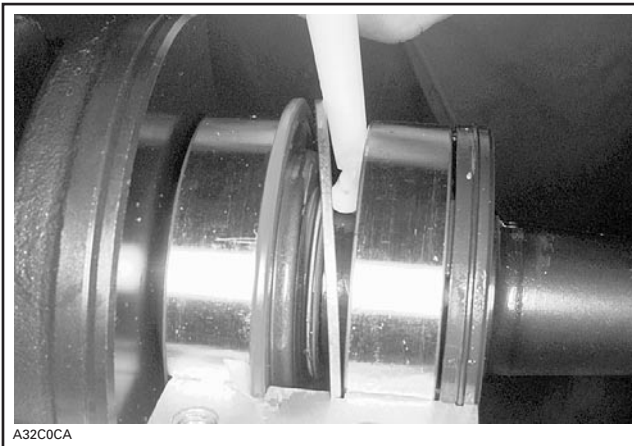

693 and 793 Engines

Apply 6 mL of grease to MAG side outer bearing.

All Engines

At crankshaft installation, position drive pins as illustrated.

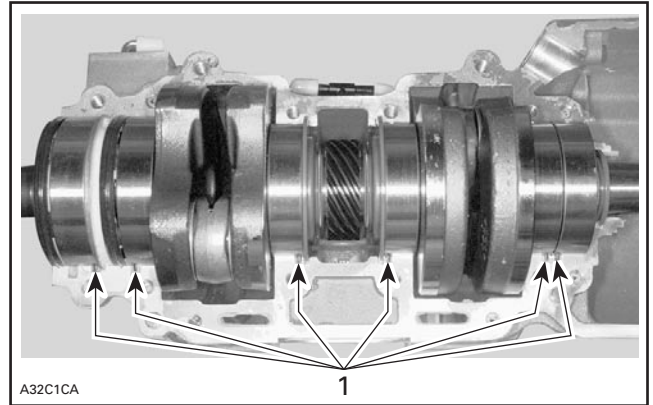

1. Position pins

Drop 50 mL (2 U.S. oz) of injection oil in the pan under central gear to lubricate pump gearing as per photo.

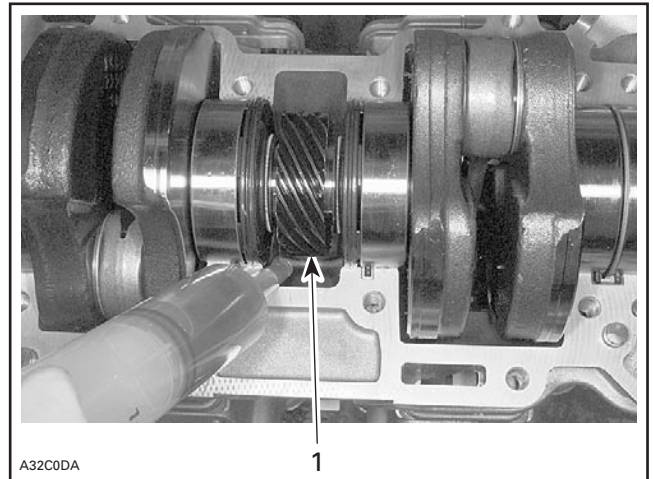

1. Oil bath

Crankcase Assembly

IMPORTANT: The total assembly sequence, including sealing compound spreading, screwing and torquing of bolts according to the proper sequence must be performed within 10 minutes. **Do not wait between each bolt torquing. All bolts must be torqued in a row.**

Before screwing both parts of crankcase, seal it with sealing compound (P/N 420 297 905). Make sure surfaces are clean and degreased before applying sealing compound.

SECTION 04 - ENGINE PREPARATION

Spread a seam of 1.2 mm (1/16 in) maximum in diameter on surface of lower crankcase half.

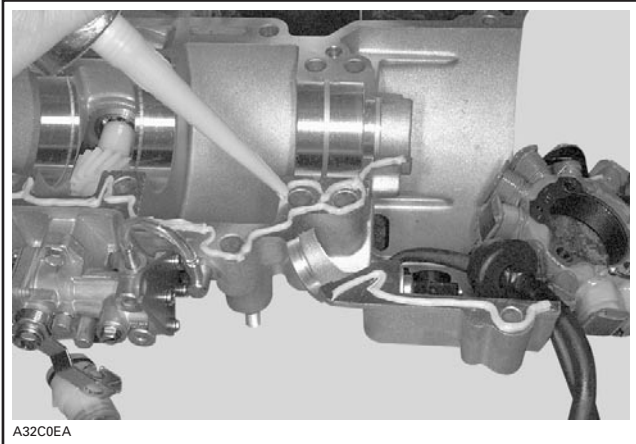

As far as possible, sealing compound must be applied in one run to avoid any risks of leaking through the crankcase.

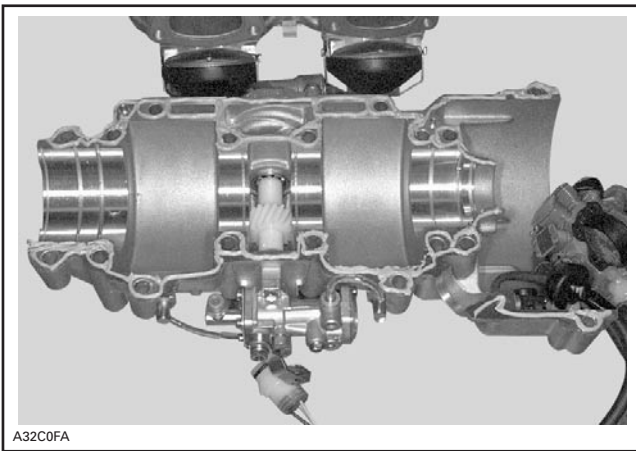

SEAMING COMPLETED — CONTACT SURFACES COVERED AND SCREW HOLES SURROUNDED

Screw all crankcase bolts in place in the following sequence and to the appropriate torque through a two steps torquing: first, screw bolts up to 60% of the final torque (18 N•m (13.5 lbf•ft) for most of the bolts), then, tighten to the required torque (i.e. 29 N•m (21 lbf•ft)).

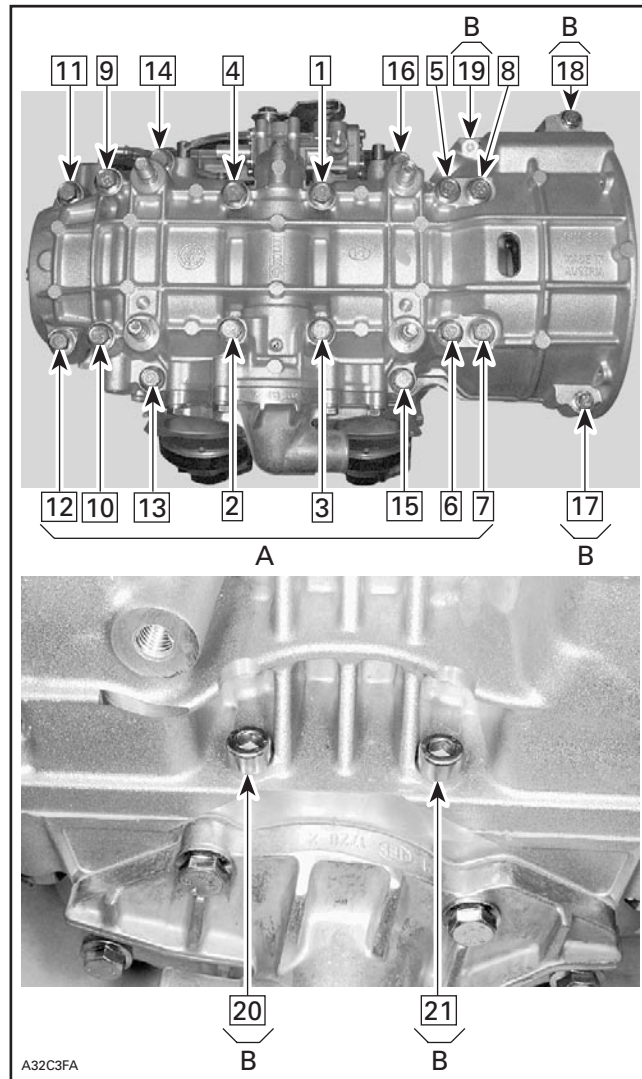

- A. Torque bolts 1 through 16 to 29 N•m (21 lbf•ft)
 B. Torque bolts 17 through 21 to 9 N•m (80 lbf•in)

BREAK-IN

After rebuilding an engine always observe a break-in period as described in *Operator's Guide*.

LEAK TEST AND ENGINE DIMENSION MEASUREMENT

LEAK TEST

The following gives verification procedures for liquid cooled engines though it also applies to fan cooled engines. For FC engines, do not consider information pertaining to coolant system and pump shaft oil gear reservoir.

On FC twin-cylinder engines, each cylinder cannot be verified individually due to leakage from one cylinder to the other through labyrinth sleeve in center of crankshaft.

PREPARATION

1. Remove tuned pipe.
2. Install plug over exhaust manifold.
3. Remove carburetors.
4. Insert plugs in intake rubber boots. Tighten with clamps already there.

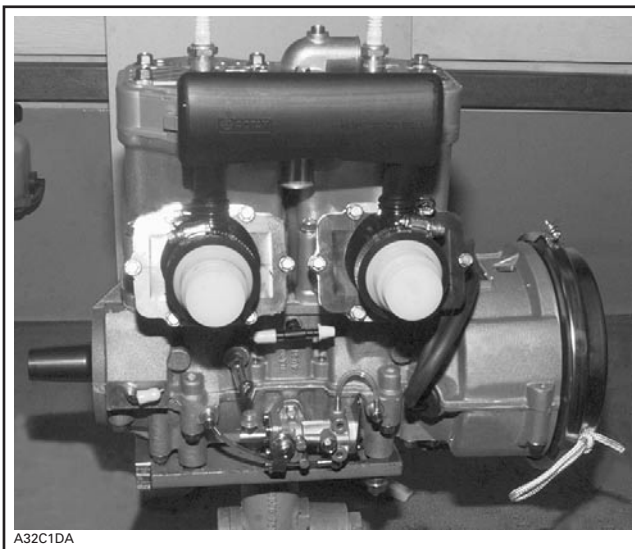

5. Using a hose pincher (P/N 295 000 076), block impulse hose.
6. Install air pump on exhaust plug.

NOTE: If necessary, lubricate air pump piston with mild soap.

CAUTION: Using hydrocarbon lubricant (such as engine oil) will damage rubber seal of pump piston.

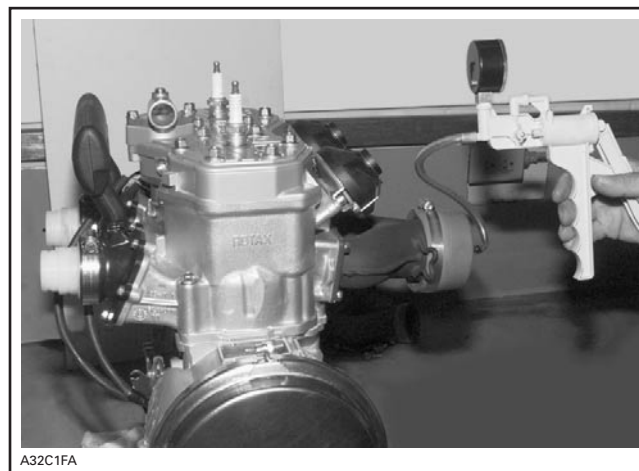

7. Activate pump and pressurize engine to 34 kPa (5 PSI). Do not exceed this pressure.
8. Engine must stand this pressure during 3 minutes. If pressure drops before 3 minutes, check tester kit by spraying a soapy solution on pump cylinder, all plugs and fittings.
 - If tester kit is leaking, bubbles will indicate where leak comes from.
 - If tester kit is not leaking, check engine as per following procedure.

PROCEDURE

NOTE: A flow chart has been prepared as a visual reference. See last page of this chapter.

Using flow chart and following text, pressurize area to be tested and spray soapy solution at the indicated location.

**TEST PRESSURE: 34 kPa (5 PSI)
for 3 minutes**

- If there is a leak at the tested location, it is recommended to continue testing next items before overhauling engine. There is a possibility of more than one leak.
- If there is no leak at the tested location, continue pumping to maintain pressure and continue with next items until leak is found.

SECTION 04 - ENGINE PREPARATION

Engine

Check the following:

1. All jointed surfaces and screw/stud threads of engine:
 - spark plug base, insulator
 - cylinder head
 - RAVE valve bellows, piston and housing
 - cylinder
 - crankcase halves (joint)
 - oil injection pump mounting flange (O-ring)
 - coolant pump housing
 - bleed screws/plugs.
2. Small injection oil lines coming from pump.

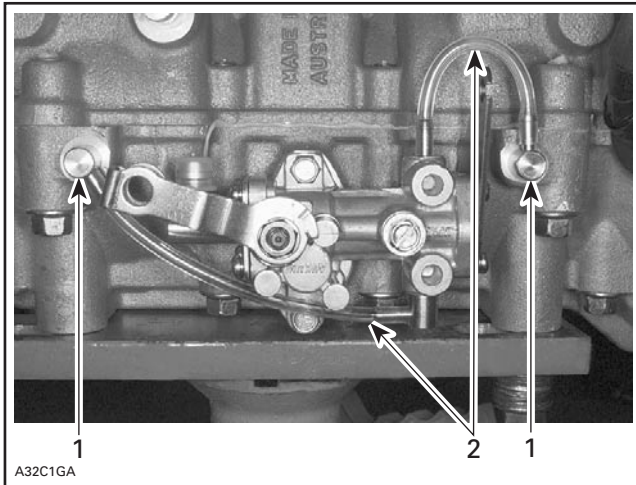

1. Injection nipples
2. Small injection oil lines

Check for air bubbles or oil column going toward pump. It indicates defective check valve in injection nipples.

3. Remove cooling system cap.

Check for air bubbles in antifreeze. It indicates defective cylinder head O-ring or cylinder base gasket.

4. Remove drive pulley then check crankshaft outer seal.
5. Remove rewind starter and magneto system then check crankshaft outer seal.
6. Check pump shaft gear oil reservoir.

Pump Shaft Oil Gear Reservoir

Install air pump on adapter and pressurize as before.

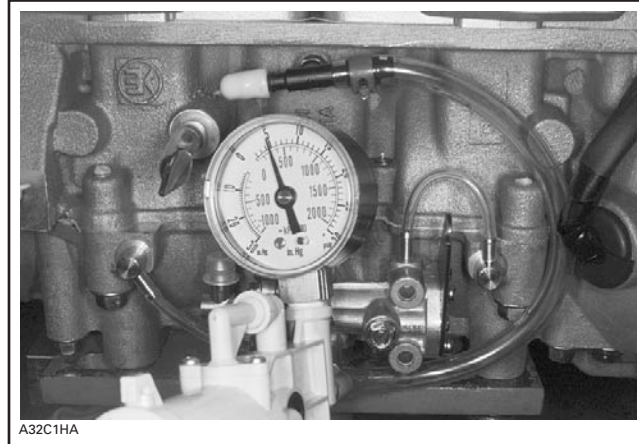

If pressure drops, it indicates a defective crankshaft inner seal.

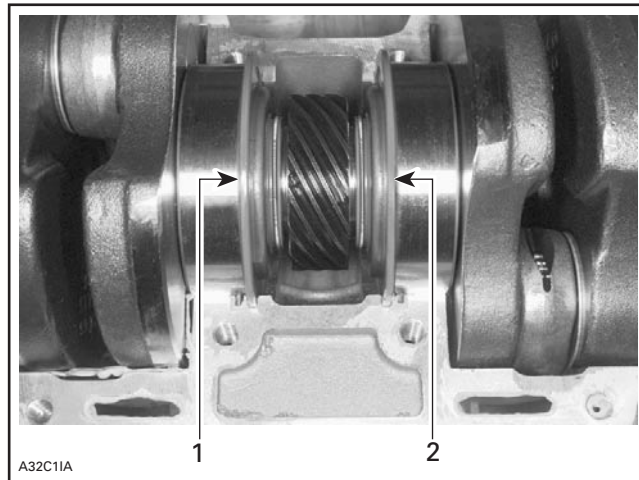

CRANKSHAFT INSTALLED IN UPPER HALF CRANKCASE

1. Crankshaft inner seal on PTO side
2. Crankshaft inner seal on MAG side

1. Check weep hole below coolant pump housing with soapy water.

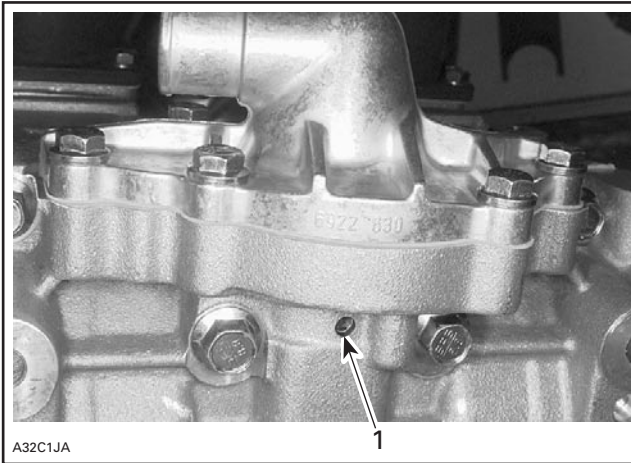

1. *Weep hole*

If there is a leak, it indicates defective seal of pump shaft (oil seal beside coolant ceramic seal).

2. Leaks can be also on oil pump side. Check mounting area for leaks.

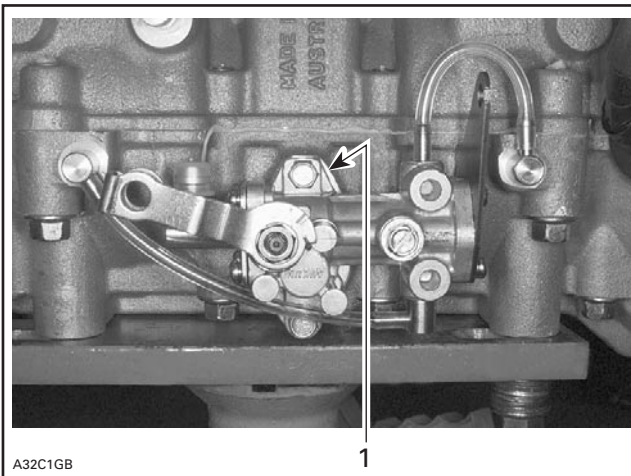

1. *Check mounting area*

3. If leak still persists, it indicates a defective casting somewhere in engine.

Disassemble engine and carefully check for defects in castings. Pay attention to tapped holes which may go through engine sealed area and thus lead to leakage.

FINALIZING REASSEMBLY

After reassembling engine, always recheck for leakage.

SECTION 04 - ENGINE PREPARATION

ENGINE LEAK VERIFICATION FLOW CHART

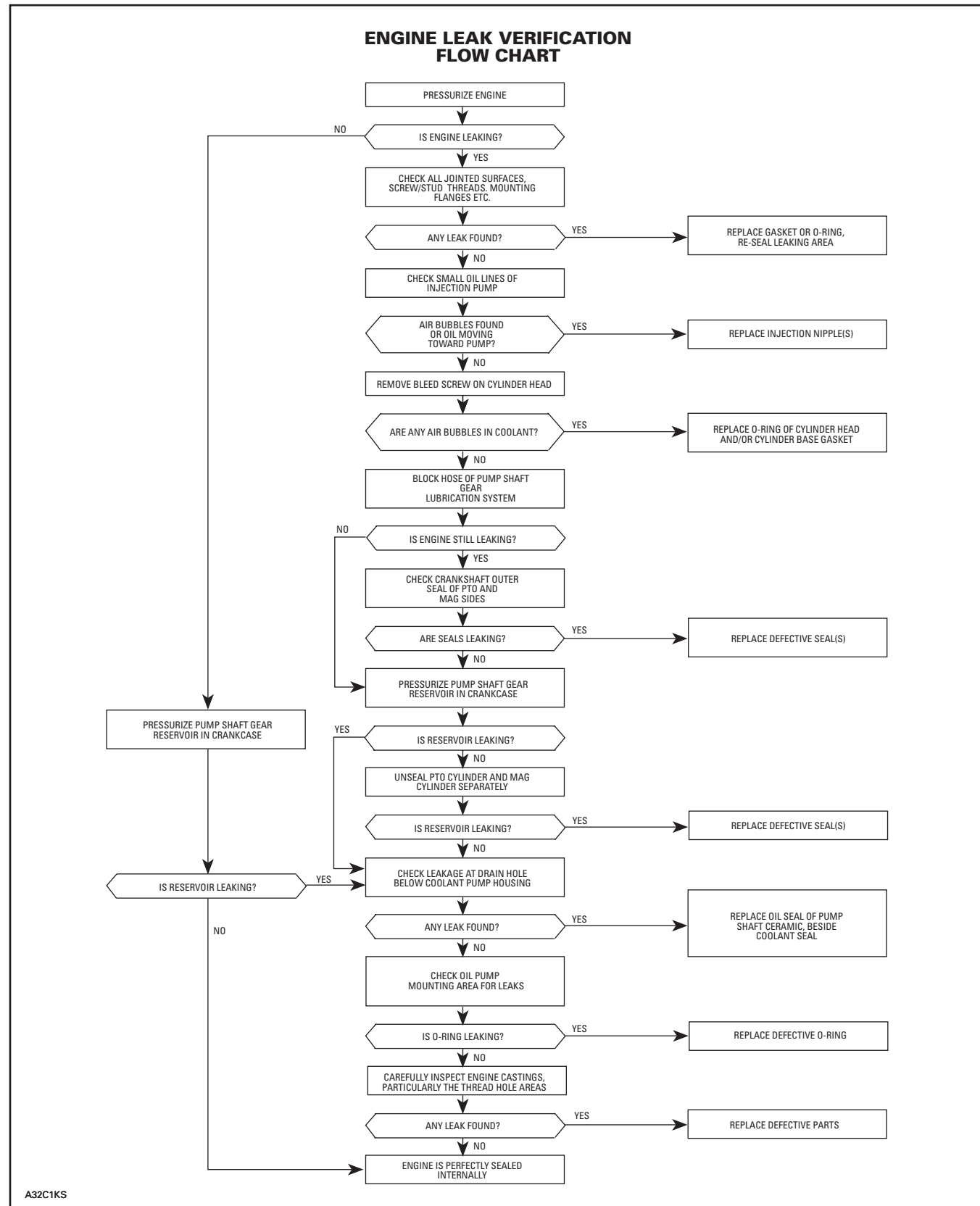

ENGINE DIMENSION MEASUREMENT

This section covers all engine types.

CYLINDER HEAD WARPAGE

ENGINE TYPE	MAXIMUM
All	0.05 mm (.002 in) per 50 mm (2 in) of surface
	0.5 mm (.020 in) for total length of cylinder head

Check gasketed surface of the cylinder head with a straightedge and a feeler gauge.

CYLINDER TAPER

ENGINE TYPE	MAXIMUM
All	0.10 mm (.004 in)

Compare cylinder diameter 16 mm (5/8 in) from top of cylinder to just below its intake port area.

If the difference exceeds the specified dimension the cylinder should be rebored and honed or should be replaced. Nikasil cylinder can be honed using diamond hone and can not be rebored.

NOTE: Be sure to restore the chamfer around all cylinder sleeve port openings.

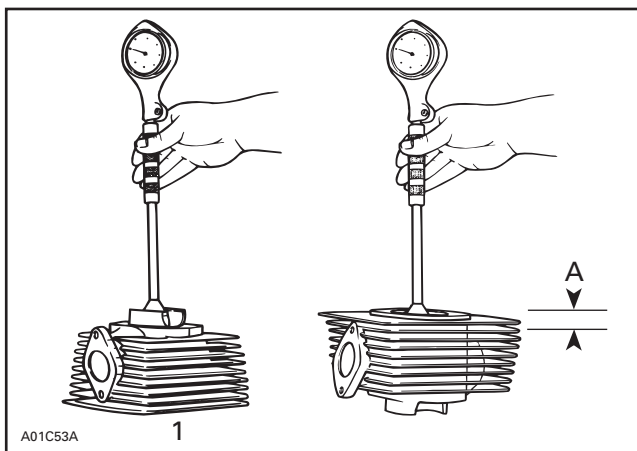

1. Below the intake port
A. 16 mm (5/8 in) from top

CYLINDER OUT OF ROUND

ENGINE TYPE	MAXIMUM
All	0.08 mm (.003 in)

Measuring 16 mm (5/8 in) from top of cylinder with a cylinder gauge, check if the cylinder out of round is more than the specified dimension. If larger, cylinder should be rebored and honed or should be replaced. Nikasil cylinder can be honed using diamond hone and can not be rebored.

NOTE: Be sure to restore the chamfer around all cylinder sleeve port openings.

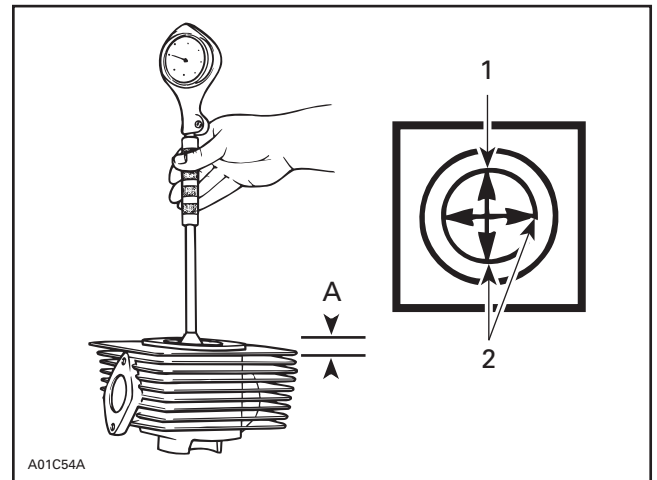

1. Piston pin position
2. Measures to be compared
A. 16 mm (5/8 in)

COMBUSTION CHAMBER VOLUME MEASUREMENT

The combustion chamber volume is the region in the cylinder head above the piston at Top Dead Center. It is measured with the cylinder head installed on the engine.

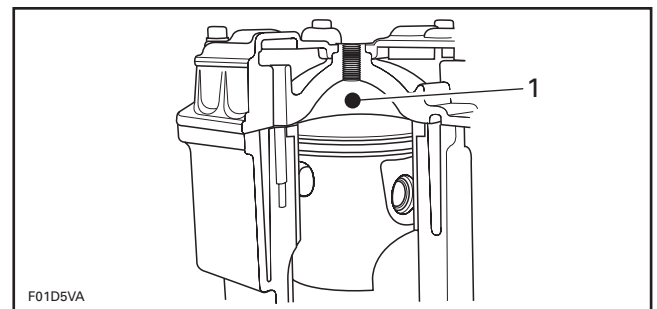

1. Combustion chamber

SECTION 04 - ENGINE PREPARATION

NOTE: When checking the combustion chamber volume, engine must be cold, piston must be free of carbon deposit and cylinder head must be leveled.

1. Remove both spark plugs and bring one piston to Top Dead Center using a TDC gauge.

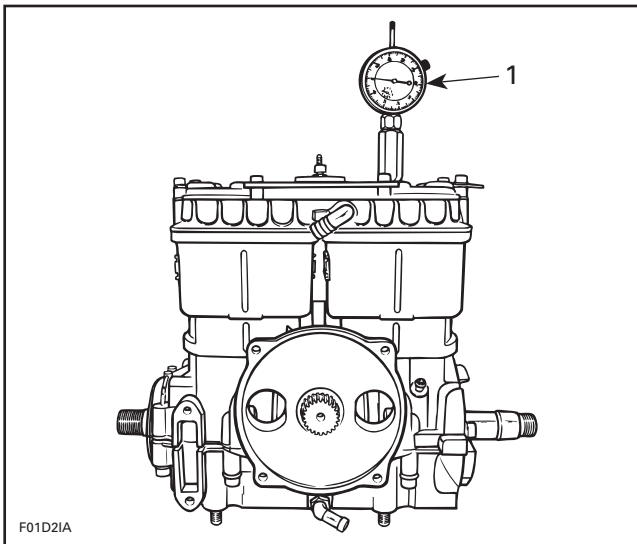

1. Bring piston to TDC

2. Obtain a graduated burette (capacity 0 - 50 cc) and fill with an equal part (50/50) of gasoline and injection oil.

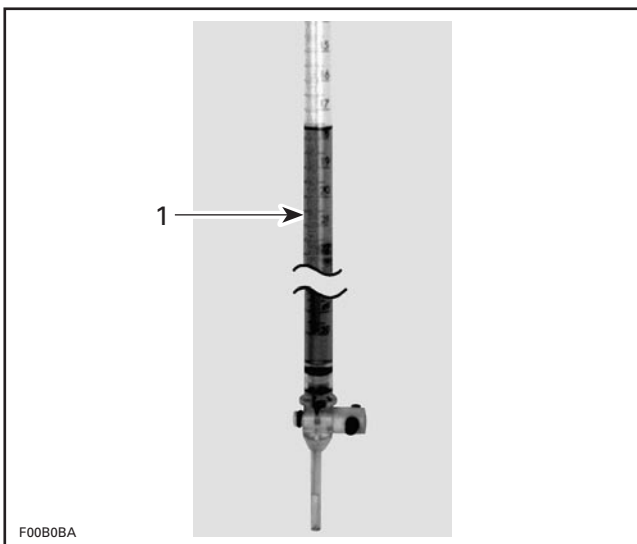

1. Graduated burette (0 - 50 cc)

3. Open burette valve to fill its tip. Add liquid in burette until level reaches 0 cc.

4. Inject the burette content through the spark plug hole until liquid touches the top spark plug hole.

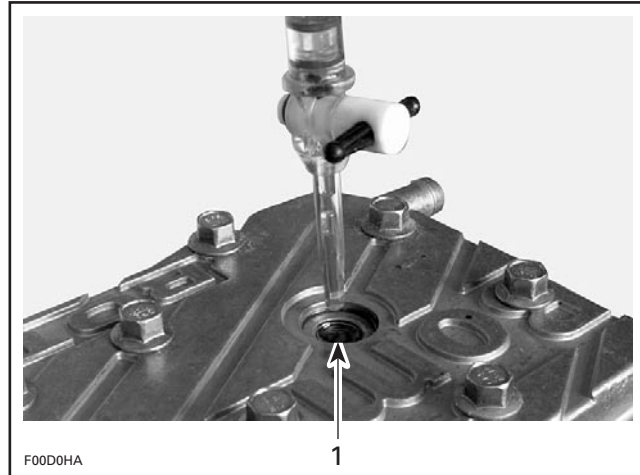

1. Top of spark plug hole

NOTE: The liquid level in cylinder must not drop for a few seconds after filling. If so, there is a leak between piston and cylinder. The recorded volume would be false.

5. Let burette stand upward for about 10 minutes, until liquid level is stabilized.
6. Read the burette scale to obtain the quantity of liquid injected in the combustion chamber.

NOTE: When the combustion chamber is filled to top of spark plug hole, it includes an amount of 2.25 cc corresponding to the spark plug well.

7. Repeat the procedure for the other cylinder.

ENGINE TYPE	COMBUSTION CHAMBER VOLUME (CC) (up to top thread of spark plug hole)
377	20.3 ± 0.8
503	27.5 ± 1.2
493	24.88 ± 1.00
593	28.86 + 1.30 - 1.20
693	33.90 + 1.51 - 1.38
793	36.34 + 1.73 - 1.58

SECTION 04 - ENGINE PREPARATION

8. Install a thicker or thinner cylinder/crankcase gasket (refer to *Parts Catalogs*) in order to obtain the specified combustion chamber volume or the nearest.

ENGINE TYPE	CHANGE IN COMBUSTION CHAMBER VOLUME (CC) FOR EVERY 0.1 mm (.004 in) OF GASKET THICKNESS
493	0.38
593	0.45
693	0.48
793	0.53

USED PISTON MEASUREMENT

Note the measurement on the piston dome.

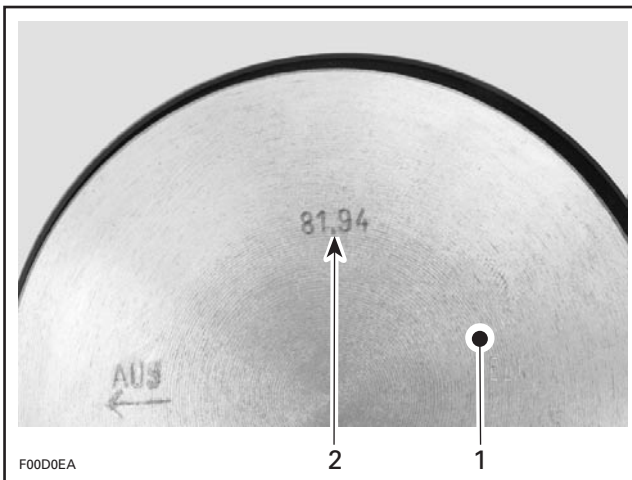

1. Piston dome
2. Piston measurement

Using a micrometer, measure piston skirt at 15 mm (.590 in) perpendicularly (90°) to piston pin.

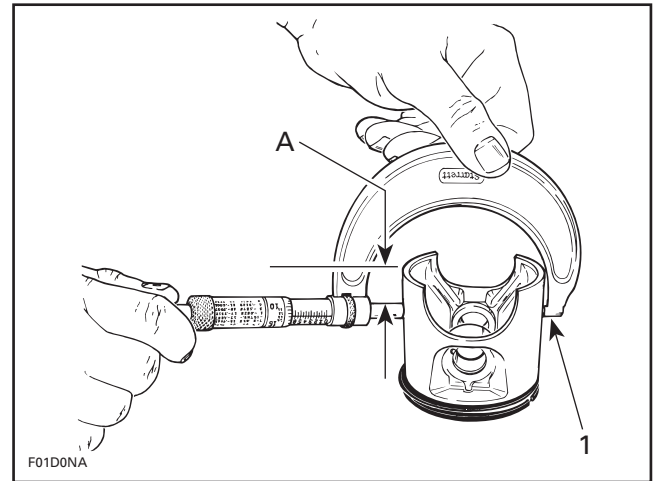

1. Measuring perpendicularly (90°) to piston pin axis
- A. 15 mm (.590 in)

ENGINE TYPE	MAXIMUM PISTON SKIRT WEAR mm (in)
All	0.15 (.006)

The measured dimension must not be less than 0.15 mm (.006 in) of the one scribed on piston dome. Otherwise, install a new piston.

CYLINDER/PISTON CLEARANCE

Used and New Pistons

IMPORTANT: Make sure used piston is not worn more than specified. See USED PISTON MEASUREMENT above.

Take the measurement on the piston dome.

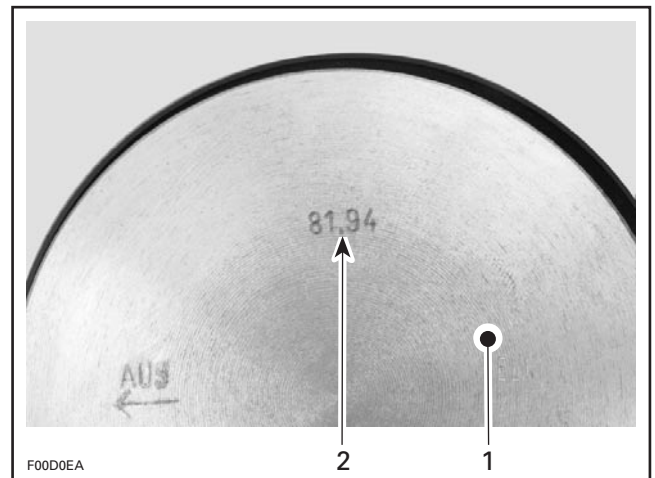

1. Piston dome
2. Piston measurement

SECTION 04 - ENGINE PREPARATION

Adjust and lock a micrometer to the specified value on the piston dome.

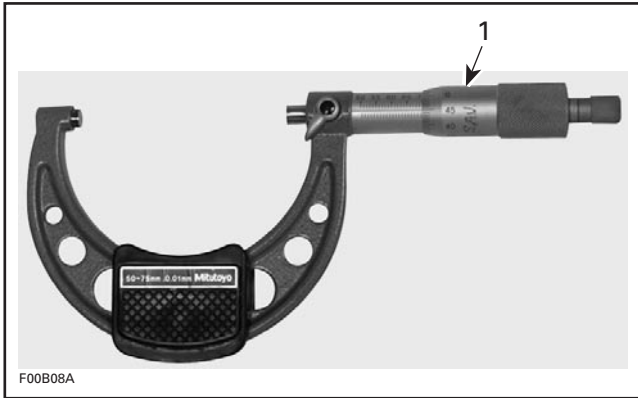

1. Micrometer set to the piston dimension

With the micrometer set to the piston dimension, adjust a cylinder bore gauge to the micrometer dimension and set the indicator to 0.

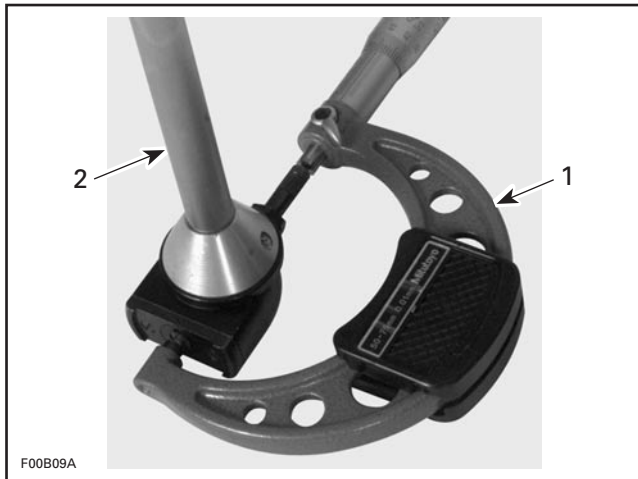

1. Use the micrometer to set the cylinder bore gauge
2. Dial bore gauge

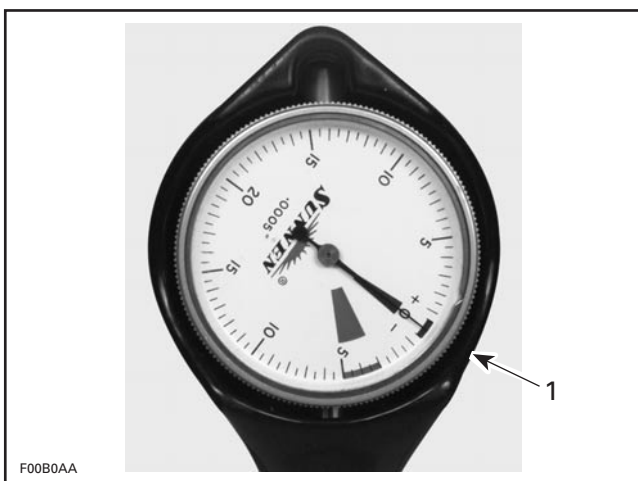

1. Indicator set to 0 (zero)

IMPORTANT: Always remove cylinders from crankcase before measuring.

Position the dial bore gauge at 16 mm (5/8 in) below cylinder top edge.

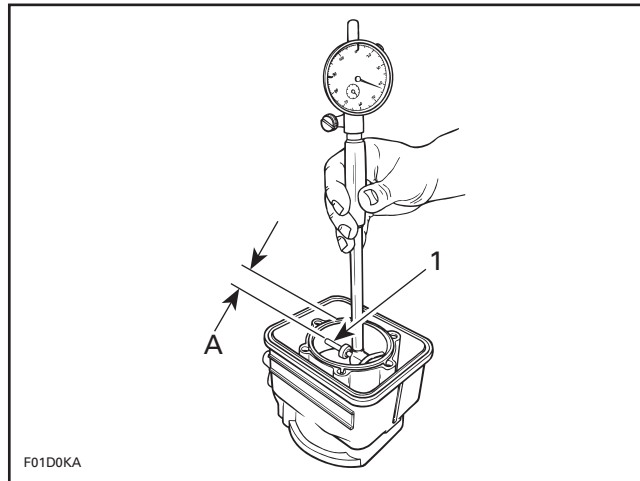

1. Measuring perpendicularly (90°) to piston pin axis
A. 16 mm (5/8 in)

Read the measurement on the cylinder bore gauge. The result is the exact piston/cylinder wall clearance. If clearance exceeds specified tolerance, replace cylinder or rebores and install oversize piston depending on engine type. Refer to TECHNICAL DATA.

NOTE: Make sure the cylinder bore gauge indicator is set exactly at the same position as with the micrometer, otherwise the reading will be false.

IMPORTANT: The total piston/cylinder clearance (actual cylinder diameter minus actual piston skirt diameter) should be within 0.30 mm (.012 in).

RING/PISTON GROOVE CLEARANCE

Using a feeler gauge check clearance between rectangular ring and groove. Replace piston if clearance exceeds specified tolerance. Refer to TECHNICAL DATA.

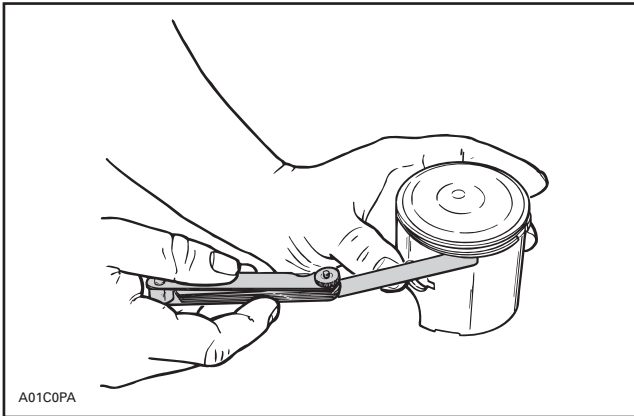

RING END GAP

Position ring half-way between transfer ports and intake port.

NOTE: In order to correctly position the ring in the cylinder, use piston as a pusher.

Using a feeler gauge, check ring end gap. Replace ring if gap exceeds specified tolerance. Refer to TECHNICAL DATA.

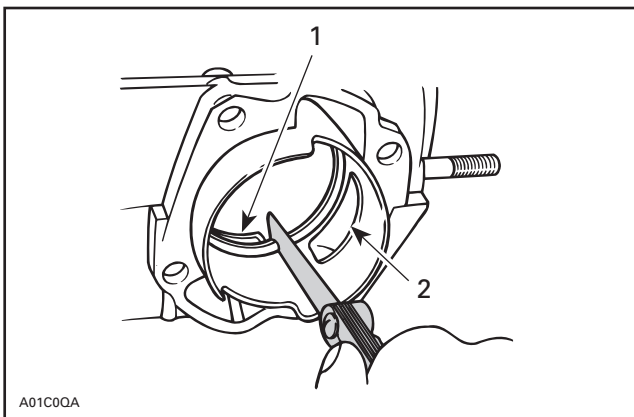

1. Transfer port
2. Intake port

CRANKSHAFT DEFLECTION

Crankshaft deflection is measured with a dial indicator.

Measuring (in crankcase)

First, check deflection with crankshaft in crankcase. If deflection exceeds the specified tolerance, recheck deflection using V-shaped blocks to determine the defective part(s). See below.

Measuring (on bench)

Once engine is disassembled, check crankshaft deflection on V-shaped blocks. If deflection exceeds the specified tolerance, it can be worn bearings or a bent crankshaft. Remove crankshaft bearings and check deflection again on V-shaped blocks to determine the defective part(s). See measurement A in following illustration.

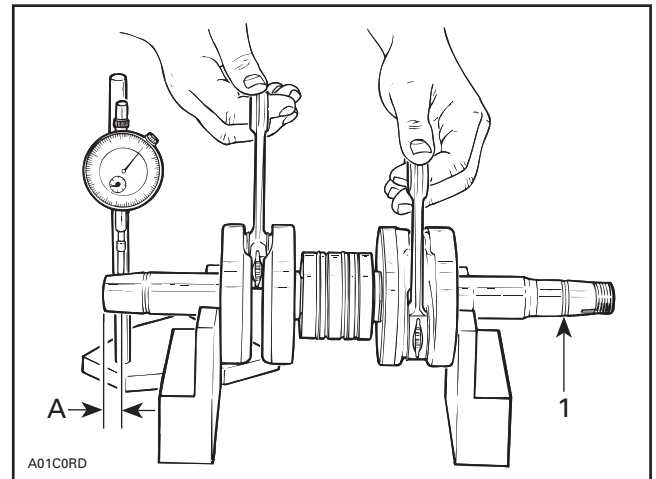

TYPICAL

1. Measure at mid point between the key and the first thread
- A. 3 mm (1/8 in)

Crankshaft Deflection on PTO Side

ENGINE TYPE	MAXIMUM ON PTO SIDE mm (in)
All	0.06 (.0024)

Crankshaft Deflection on MAG Side

ENGINE TYPE	MAXIMUM ON MAG SIDE mm (in)
All	0.05 (.002)

SECTION 04 - ENGINE PREPARATION

Crankshaft Deflection in Center of Crankshaft

ENGINE TYPE	MAXIMUM IN CENTER OF CRANKSHAFT mm (in)
All	0.08 (.0031)

NOTE: Crankshaft deflection cannot be correctly measured between centers of a lathe.

If the deflection exceeds the specified tolerance, crankshaft should be repaired or replaced.

CONNECTING ROD BIG END AXIAL PLAY

ENGINE TYPE	NEW PARTS MIN. - MAX.	WEAR LIMIT
All	0.39 - 0.74 mm (.015 - .029 in)	1.20 mm (.047 in)

Using a feeler gauge, measure distance between thrust washer and crankshaft counterweight. If the distance exceeds specified tolerance, repair or replace the crankshaft.

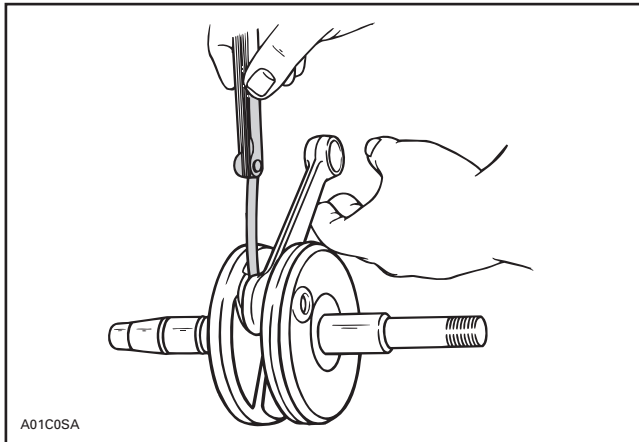

TYPICAL

CRANKSHAFT END-PLAY

All Engine Types

End-play is not adjustable but it should be between 0.10 - 0.30 mm (.004 - .012 in).

CHECKING CRANKSHAFT ALIGNMENT

Install a degree wheel (P/N 529 035 607) on crankshaft end.

Remove both spark plugs.

Install a TDC gauge (P/N 414 104 700) in spark plug hole on MAG side.

Bring MAG piston at top dead center.

Rotate degree wheel (not crankshaft) so that 360° mark aligns with center of crankcase. Scribe a mark on crankcase.

Remove TDC gauge and install it on center cylinder.

Bring PTO piston to top dead center. Degree wheel must rotate with crankshaft.

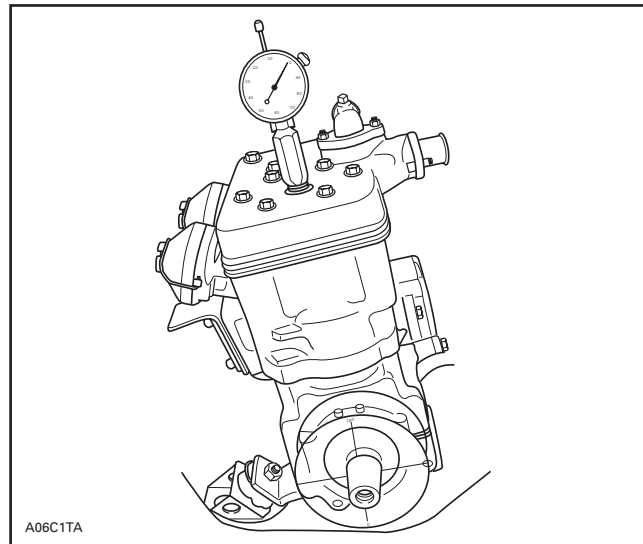

TYPICAL

Interval between cylinders must be $180^\circ \pm 0.5$.

Any other reading indicates a misaligned (twisted) crankshaft.

CDI SYSTEM

DENSO TRIGGER COIL IGNITION SYSTEM

290 W on ZX Series

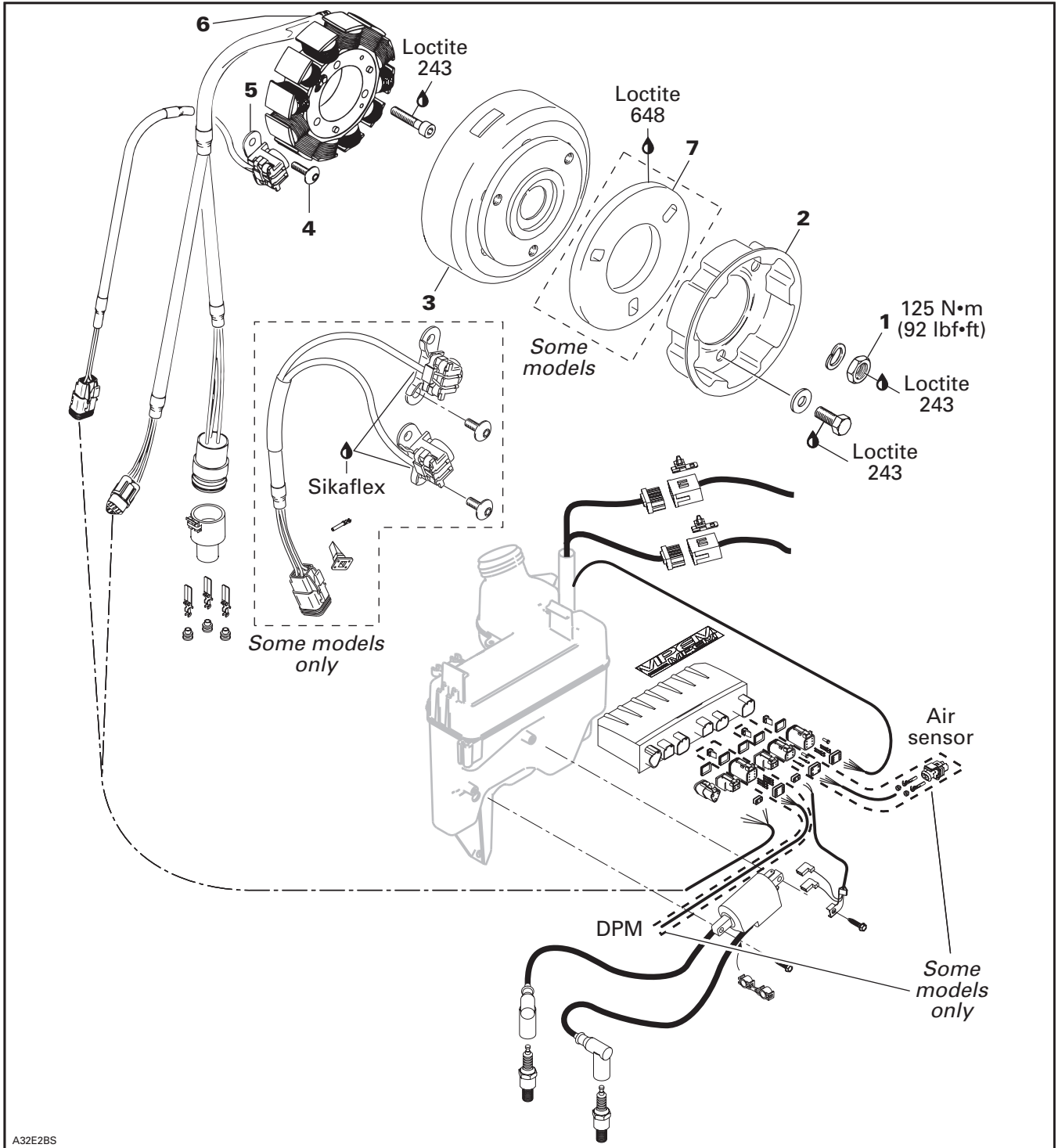

SECTION 04 - ENGINE PREPARATION

300 W on ZX Series

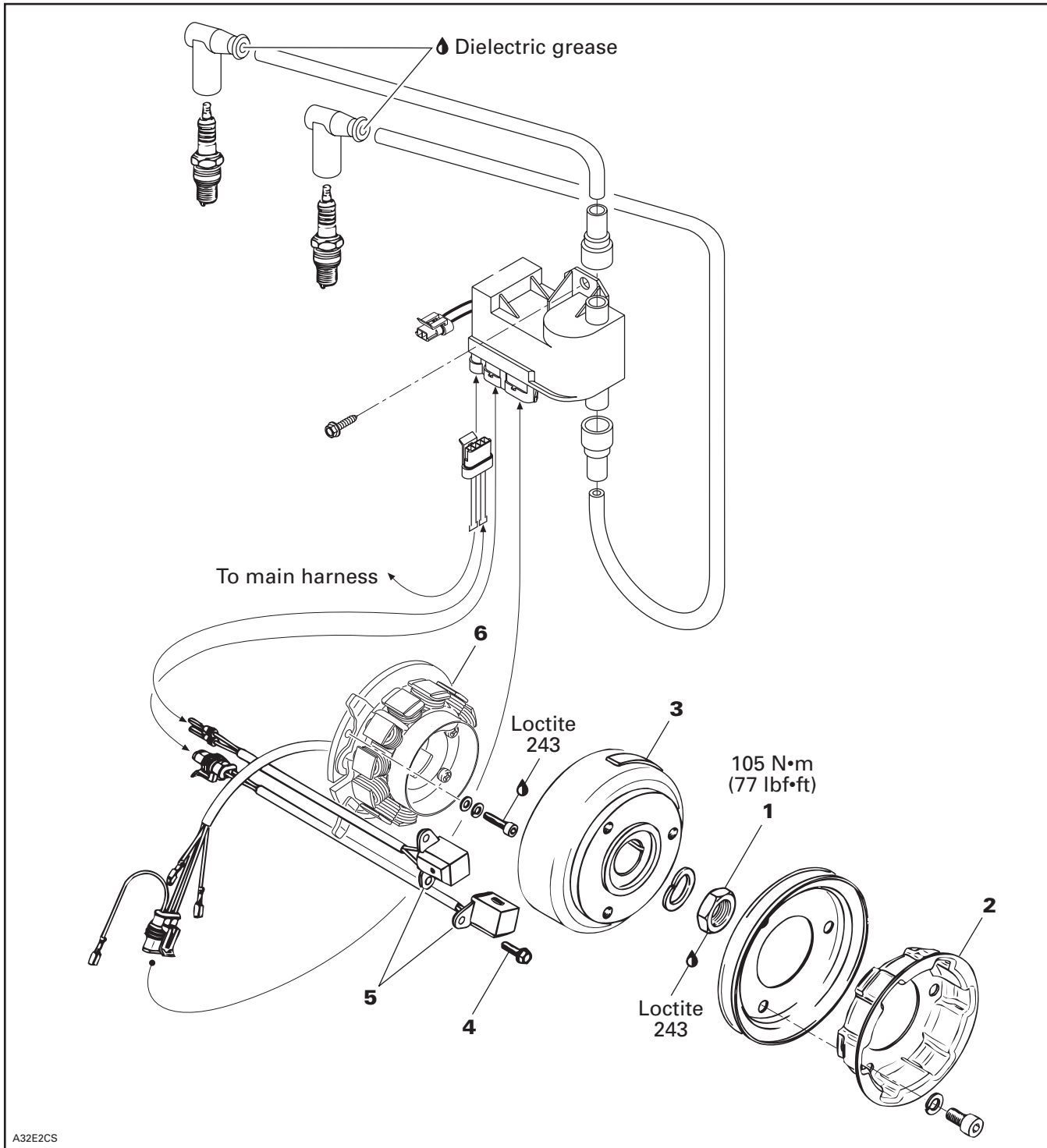

A32E2CS

SECTION 04 - ENGINE PREPARATION

360 W on ZX Series

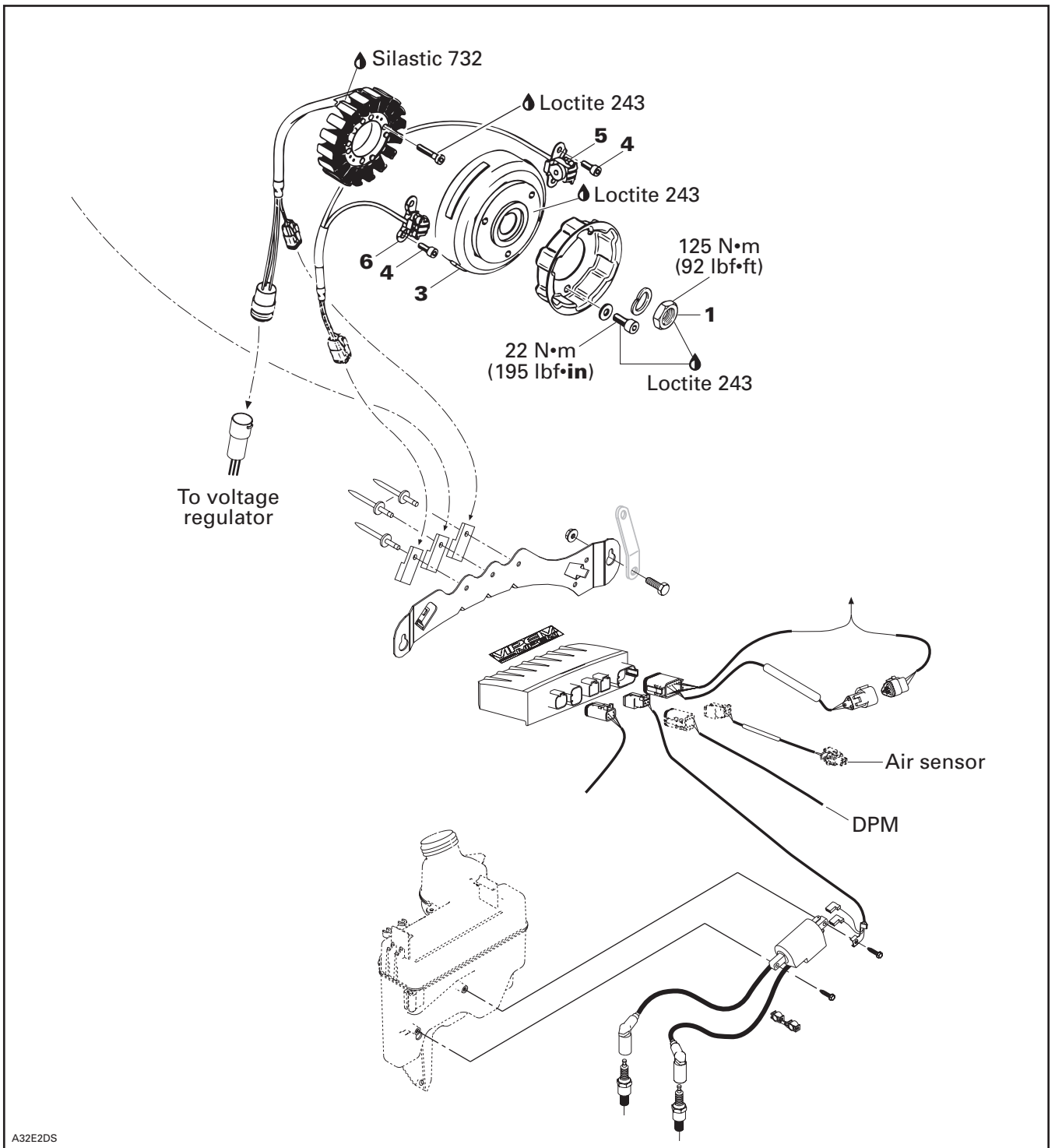

A32E2DS

SECTION 04 - ENGINE PREPARATION

NOTE: The following procedures can be done without removing the engine from chassis. To facilitate magneto removal, hold drive pulley with tool (P/N 529 027 600).

CDI means Capacitor Discharge Ignition System.

CLEANING

Clean all metal components in a non-ferrous metal cleaner.

CAUTION: Clean stator and magneto using only a clean cloth.

DISASSEMBLY

3, Magneto Flywheel

To gain access to magneto assembly, remove the following parts as needed on different engines:

- tuned pipe and muffler
- rewind starter
- starting pulley **no. 2**.

To remove magneto flywheel retaining nut **no. 1**:

- Use magneto puller ring (P/N 420 876 080). Former puller has to be modified as shown.

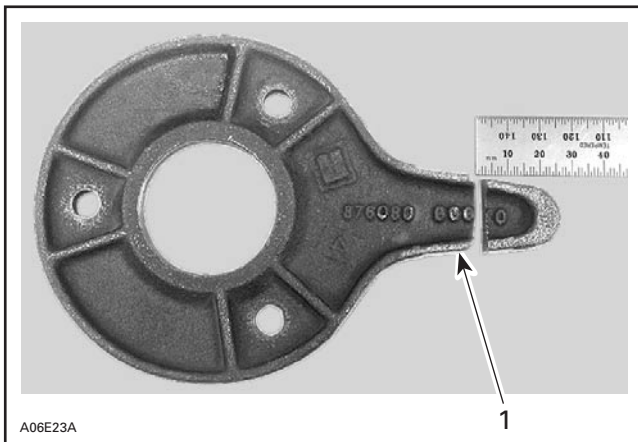

1. Cut by 25 mm (1 in)

- Install puller ring with its tab in magneto housing opening.

CAUTION: Use only M8 x 20 mm screws to bolt puller to magneto. When a flywheel **no. 7 (for liquid cooled models only)** is installed on magneto flywheel use M8 x 30 mm screws.

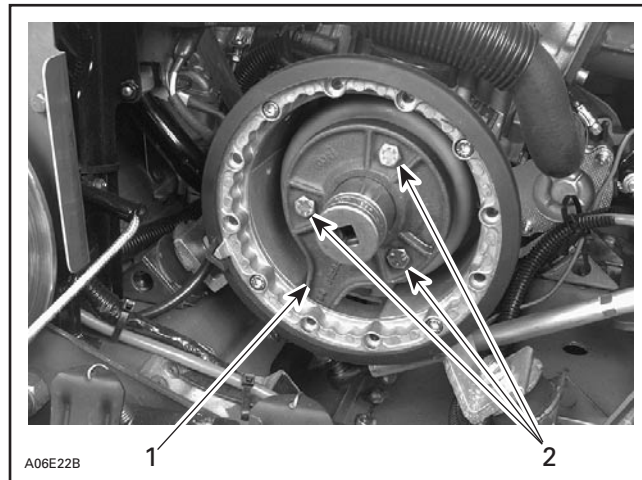

TYPICAL

1. Tab in magneto housing opening
2. M8 screws

- Remove magneto flywheel nut, using a 30 mm socket machined to 40 mm (1.580 in) outside diameter by 16 mm (5/8 in) long.

NOTE: To correctly remove a threadlocked fastener it is first necessary to tap on the fastener to break threadlocker bond. This will eliminate the possibility of thread breakage.

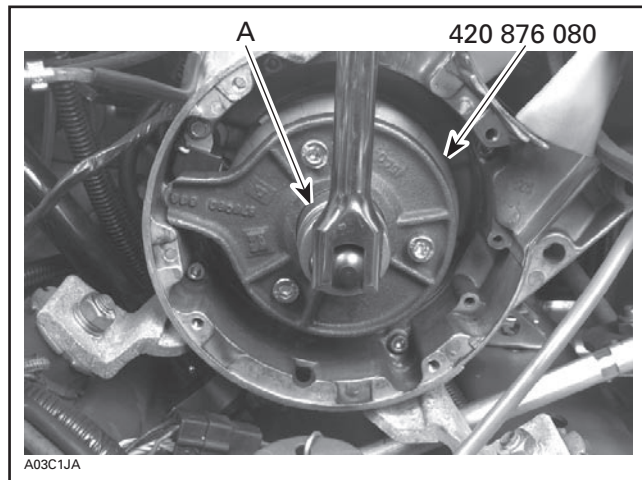

TYPICAL

- A. 30 mm socket

To remove magneto flywheel, install crankshaft protector (P/N 420 876 557) on crankshaft end. Screw puller (P/N 529 022 500) into puller ring.

- Tighten puller bolt and at the same time, tap on bolt head using a hammer to release magneto flywheel from its taper.

5, Trigger Coil

NOTE: Trigger coils equipped with GN/BL and GY/BL wires are available as spare parts only. These trigger coil can replace any trigger coils installed on RER models.

Magneto and stator **no. 6** must be removed before trigger coil removal.

To replace trigger coil:

- Disconnect trigger coil connector housing.
- Remove grommet from crankcase where trigger coil wire exits magneto housing.
- Remove retaining screws **no. 4**.
- Remove trigger coil and carefully pull wires.
- Install new trigger coil and other parts removed.

ASSEMBLY

For Liquid Cooled Models Only

7, Stator Plate

Make sure to position stator plate in a way that its wire protectors are over recess of crankcase.

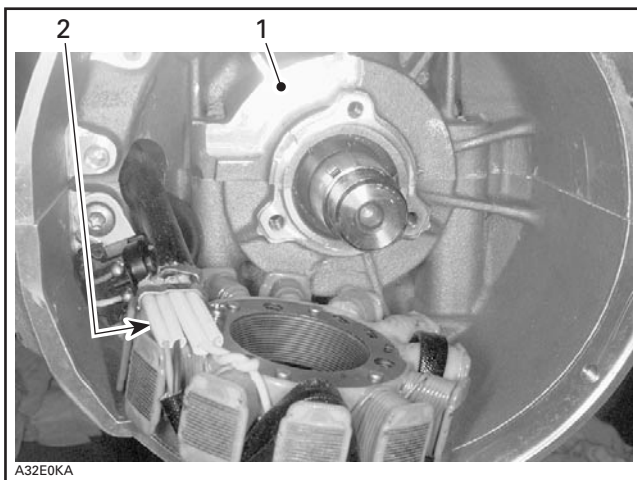

1. Crankcase recess
2. Wire protectors

All Models

3, Magneto Flywheel

Clean crankshaft extension (taper) and apply Loctite 243 (blue) on taper, then position Woodruff key, flywheel and lock washer on crankshaft.

Clean nut threads and apply Loctite 243 (blue) then tighten nut to 105 N•m (77 lbf•ft) for fan cooled engines and to 125 N•m (92 lbf•ft) for liquid cooled engines.

At reassembly coat all electric connections except Deutsch housings (waterproof gray housing) with silicone dielectric grease (P/N 293 550 004) to prevent corrosion or moisture penetration.

CAUTION: Do not use silicone “sealant”, this product will corrode contacts. Do not apply silicone dielectric grease on any Deutsch (gray) housing otherwise housing seal will be damaged.

Ignition Timing

Check as described in IGNITION TIMING.

OIL INJECTION SYSTEM

OIL INJECTION PUMP

493, 593, 693 and 793 Engines

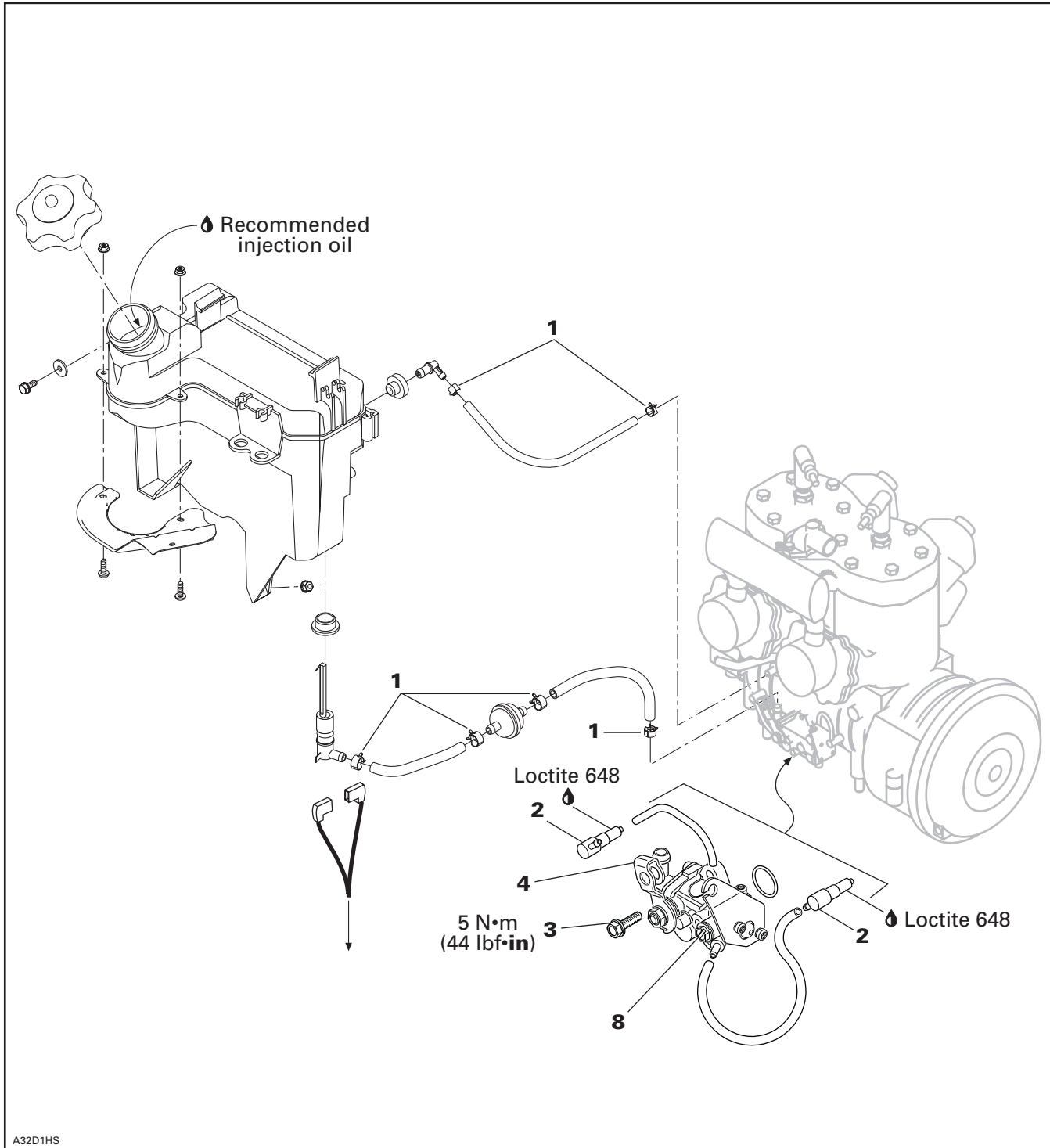

377 and 503 Fan Cooled Engines



⚠ WARNING

Wipe off any oil spills. Oil is highly flammable.

OIL TYPE

All Models

Use recommended injection oil as per vehicle *Operator's Guide*.

OIL SYSTEM LEAK TEST

All Models

The following test will indicate any leak from oil reservoir to the banjo fitting(s).

Install on oil reservoir special cap of leak testing kit (P/N 529 033 100).

Install hose pinchers (P/N 295 000 076) on outlet hoses.

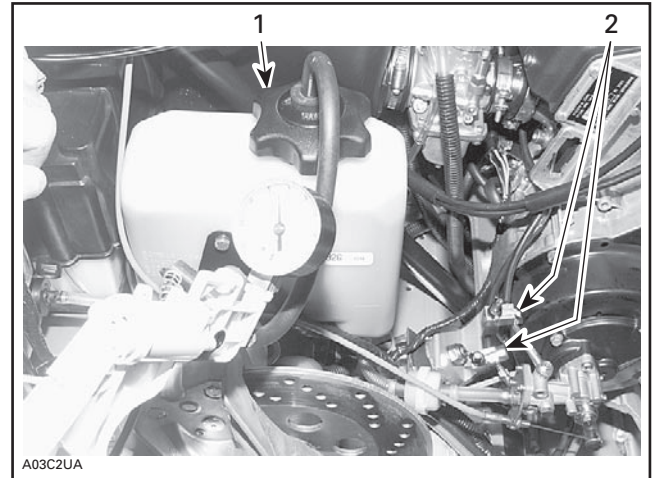

TYPICAL

1. Special cap on reservoir
2. Hose pinchers on outlet hoses

Connect leak testing kit pump to special cap.

Pressurize oil system to 21 kPa (3 PSI). That pressure must not drop during 3 minutes.

If pressure drops, locate leak(s) and repair/replace leaking component(s).

OIL PUMP IDENTIFICATION

4, Pump Lever

Different engines need different pumps. See identification on lever no. 4.

CAUTION: Always mount proper pump on engine.

ENGINE TYPE	OIL PUMP IDENTIFICATION
377	L13
493	02
503	E8
593	02
693	01
793	01

NOTE: The following procedures can be done without removing the engine from chassis.

SECTION 04 - ENGINE PREPARATION

CLEANING

Clean all metal components in a non-ferrous metal cleaner.

DISASSEMBLY

NOTE: Some oil pump components are not available as single parts.

ASSEMBLY

1, Spring Clip

Always check for spring clips tightness.

3, Screw

Torque to 5 N•m (44 lbf•in).

Cable plastic elbow must be fastened and fully inserted.

Make sure cable barrel is well seated in oil pump lever.

Secure barrel with plastic washer and circlip.

Install cable lock washer on left side of support.

Verify cable and oil pump lever operation.

ADJUSTMENT

Fan Cooled Engines

Prior to adjusting the pump, make sure all carburetor adjustments are completed and engine is stopped.

Eliminate the throttle cable free-play by pressing the throttle lever until a light resistance is felt, then hold in place.

The mark on the pump casting and on the lever must align. Width of lever mark is the tolerance.

Loosen the adjuster nut and adjust accordingly.

Retighten the adjuster nut.

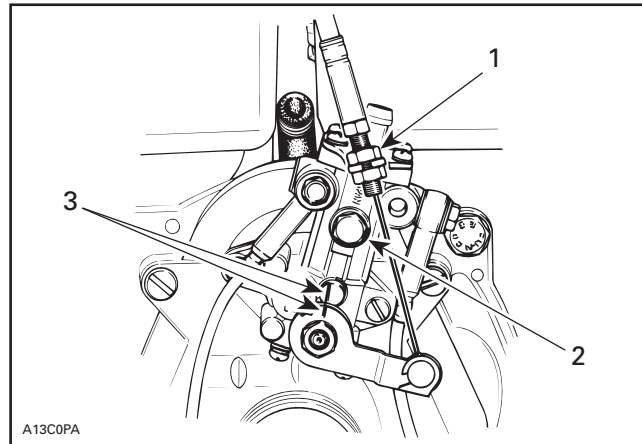

TYPICAL

1. Adjuster nut
2. Bleeder screw
3. Marks

CAUTION: Proper oil injection pump adjustment is very important. Any delay in the opening of the pump can result in serious engine damage.

Liquid Cooled Engines

Prior to adjusting the pump, make sure all carburetor adjustments are completed and engine is stopped.

Stretch the adjusting cable through a maximum force of 32 N•m (7.2 lbf•ft).

NOTE: It is better to have two persons to check the cable distance.

Check the visible distance of the stretched cable, while one person is stretching it and other checking the distance.

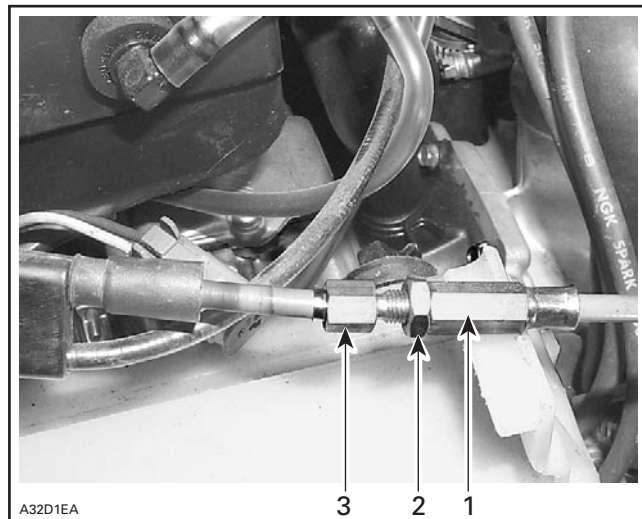

1. Adjusting cable
2. Lock nut
3. Adjusting screw

The visible stretched distance of the cable should be 28.0 ± 0.3 mm (1.102 ± 0.012 in).

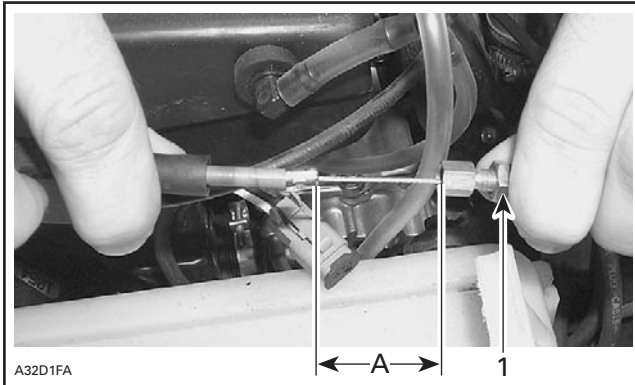

1. Lock nut
B. Visible distance = 28.0 ± 0.3 mm (1.102 ± 0.012 in)

If the visible distance is less or more than specified above, adjust the cable distance accordingly. To do so, loosen lock nut, turn adjusting screw in or out, retighten lock nut.

To Bleed Oil Lines

Bleed main oil line (between tank and pump) by loosening the bleeder screw **no. 8** until air has escaped from the line. Add injection oil as required.

Reinstall all parts.

Bleed the small oil line between pump and engine by running engine at idle while holding the pump lever in fully open position.

NOTE: Make a J hook out of mechanical wire to lift the lever.

WARNING

Ensure not to operate carburetor throttle mechanism. Secure the rear of the vehicle on a stand.

CHECKING OPERATION

Oil Pump

On Vehicle

NOTE: Main oil line must be full of oil. See bleeding procedure above.

Lift rear of vehicle and support with a mechanical stand. Unplug small oil lines from pump. Start engine and stop it as soon as it fires.

Check that oil in small oil lines has been sucked up (this will be indicated by a clear section of small oil lines). Repeat the procedure until this condition is attained.

Reconnect small oil lines, start engine and run at idle while holding the pump lever in fully open position. Oil columns must advance into small oil lines.

If not, remove pump assembly and check the pump gear and drive shaft (if applicable) for defects, replace as necessary. Test pump as describes below.

NOTE: Through normal use, oil level must not drop in small tubes. If oil drops, verify check valve operation in injection nozzle. Replace as necessary.

Test Bench

Connect a hose filled with injection oil to main line fitting. Insert other hose end in an injection oil container. Using a clockwise rotating drill rotate pump shaft. Oil must drip from outer fittings while holding lever in a fully open position. If not replace pump.

2, Check Valve

To verify this check valve, proceed the same as for checking pump operation on vehicle. First unplug oil line from check valve. After restarting the engine, check that a clear section in small oil line is present. Reconnect oil line.

Run engine at idle. Oil column must advance. If the check valve is faulty, oil column will go back and forth. Replace if so.

SECTION 04 - ENGINE PREPARATION

593, 693 and 793 Engines

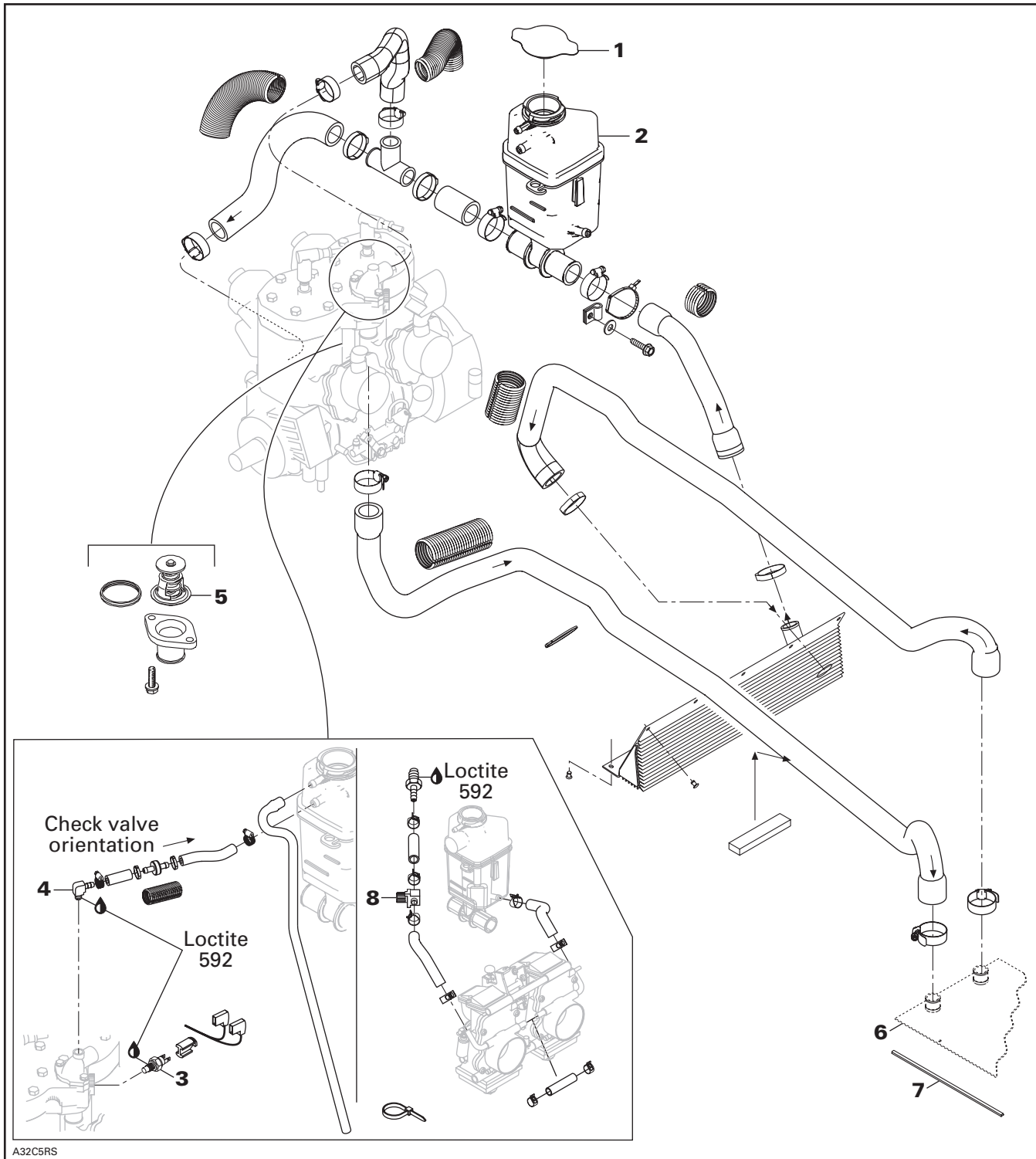

COOLING SYSTEM LEAK TEST

Install special radiator cap (P/N 529 021 400) included in engine leak tester kit (P/N 861 749 100) on coolant tank. Install hose pincher (P/N 295 000 076) on overflow hose. Using pump also included in kit pressurize all system through coolant reservoir to 100 kPa (15 PSI).

Check all hoses and cylinder/base for coolant leaks. Spray a soap/water solution and look for air bubbles.



INSPECTION

Check general condition of hoses and clamp tightness.

DRAINING THE SYSTEM

⚠ WARNING
 Never drain or refill the cooling system when engine is hot.

To drain the cooling system, siphon the coolant mixture from the coolant tank. Disconnect hose at water pump.

DISASSEMBLY AND ASSEMBLY

3,4, Sender and Plug or Elbow

Apply Loctite 592 (P/N 413 702 300) thread sealant on sender and plug or elbow to avoid leaks.

1, Pressure Cap

Check if the cap pressurizes the system. If not, install a new 90 kPa (13 PSI) cap (do not exceed this pressure).

6,7, Radiator and Radiator Protector

Insert radiator protector into radiator C-rail and crimp C-rail at rear end. Refer to FRAME for radiator removal.

5, Thermostat

To check thermostat, put in water and heat water. Thermostat should start to open when water temperature reaches the following degree. It will be almost fully open at 50°C (122°F).

ENGINE	TEMPERATURE
493, 593, 693 and 793	42°C (108°F)

Thermostat is a double action type.

- a. Its function is to give faster warm up of the engine by controlling a circuit; water pump — engine — coolant tank. This is done by bypassing the radiator circuit.

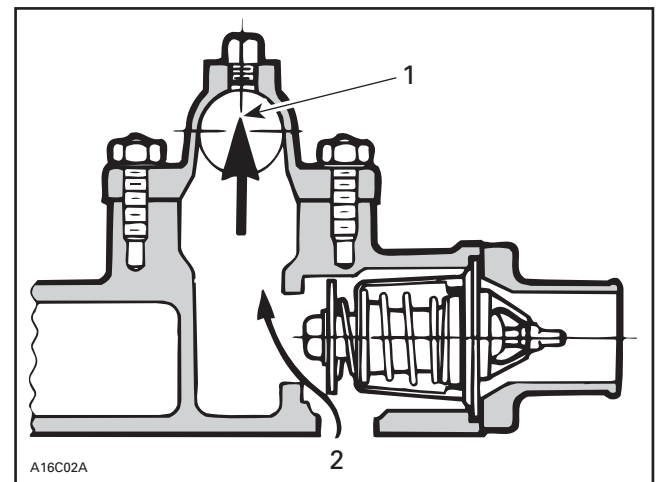

TYPICAL — CLOSED THERMOSTAT, COLD ENGINE

- 1. To reservoir
- 2. From cylinders

SECTION 04 - ENGINE PREPARATION

- b. When the liquid is warmed enough, the thermostat opens progressively the circuit, water pump — engine — radiators — coolant tank to keep the liquid at the desired temperature. (See the diagram of the exploded view).

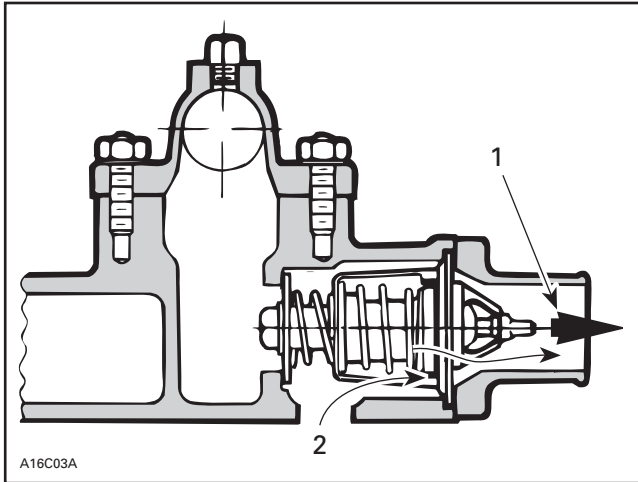

TYPICAL — OPEN THERMOSTAT, WARM ENGINE

1. To radiators
2. From cylinders

These 2 functions have the advantage of preventing a massive entry of cold water into the engine.

COOLING SYSTEM REFILLING PROCEDURE

CAUTION: To prevent rust formation or freezing condition, always replenish the system with recommended premixed coolant.

System Capacity

Refer to TECHNICAL DATA.

Refilling Procedure

For 493, 593, 693, and 793 Engines

IMPORTANT: USE THE 50/50 PREMIXED COOLANT - 40°C (- 40°F). Do not reinstall pressure cap.

With engine cold, refill coolant tank up to COLD LEVEL line. Start engine. Refill up to line while engine is idling until rear radiators are warm to the touch (about 4 to 5 minutes). Always monitor coolant level while filling tank to avoid emptying. Install pressure cap.

Lift rear of vehicle and support it safely.

Activate throttle lever 3 - 4 times to bring engine speed to 7000 RPM.

Apply the brake.

Lower vehicle back on ground and add coolant up to 15 mm (1/2 in) above the COLD LEVEL line.

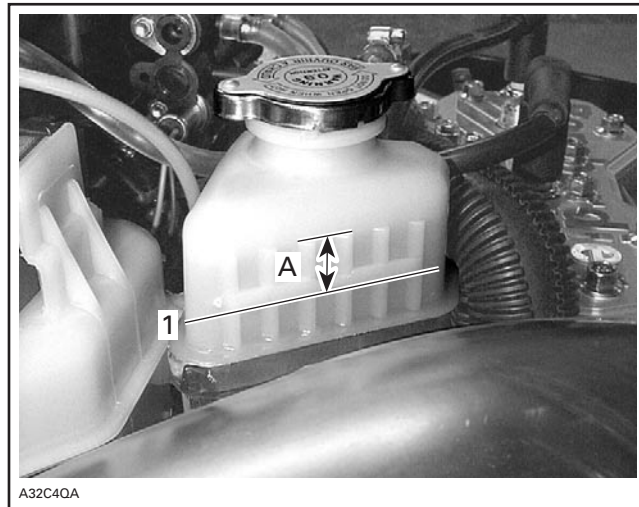

1. Cold level line
- A. 15 mm (1/2 in)

Lift front of vehicle of 60 cm (24 in) and support it safely. Let the vehicle idle for two minutes.

Put vehicle back on ground and add coolant up to 15 mm (1/2 in) over COLD LEVEL line.

When engine has completely cooled down, recheck coolant level in coolant tank and refill up to line if needed.

Check for coolant mixture freezing point. Specification is - 40°C (- 40°F). Adjust as necessary.

REWIND STARTER

Plastic Rewind Starter on ZX Liquid Cooled Models

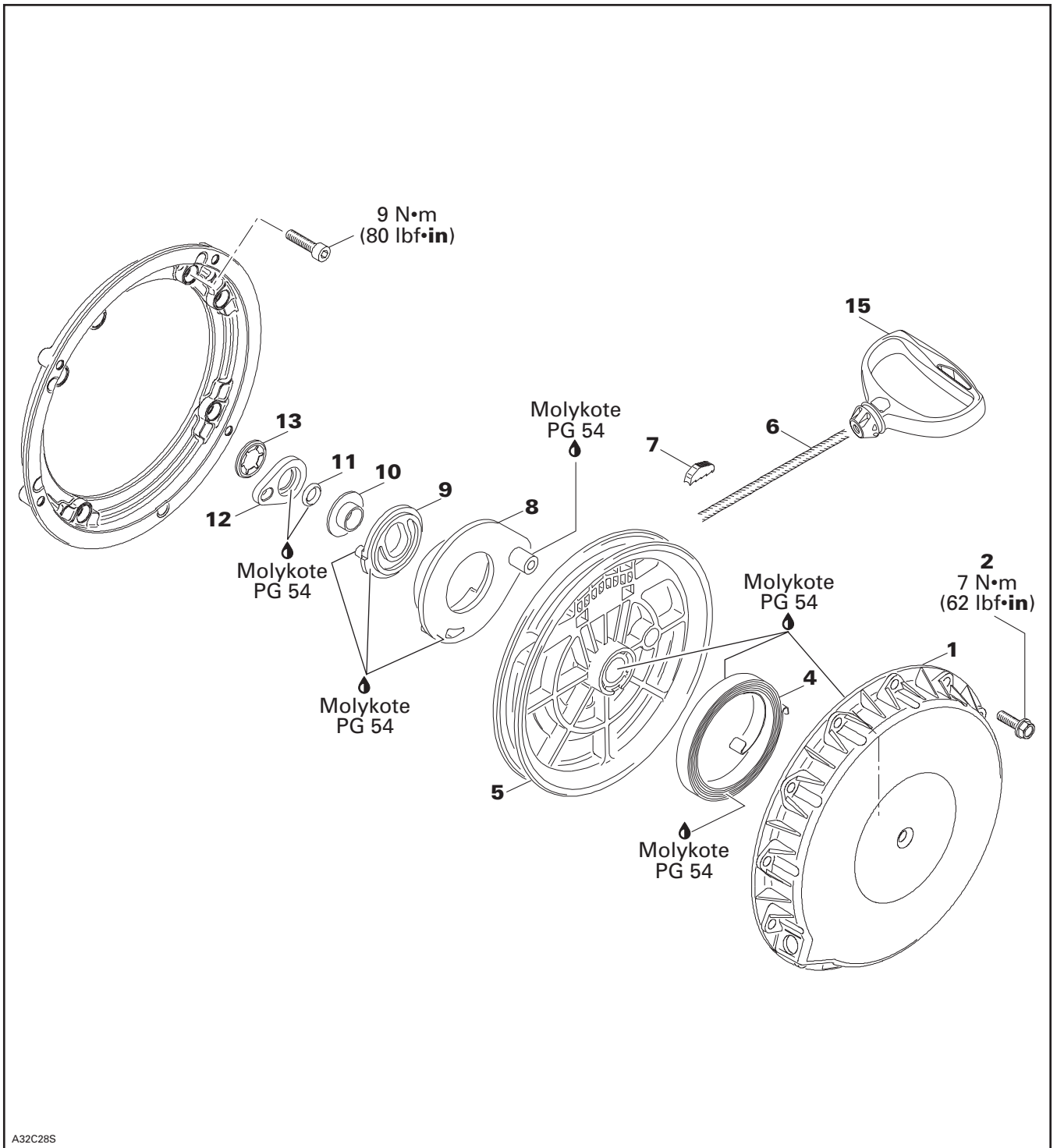

A32C28S

SECTION 04 - ENGINE PREPARATION

Plastic Rewind Starter on ZX Fan Cooled Models

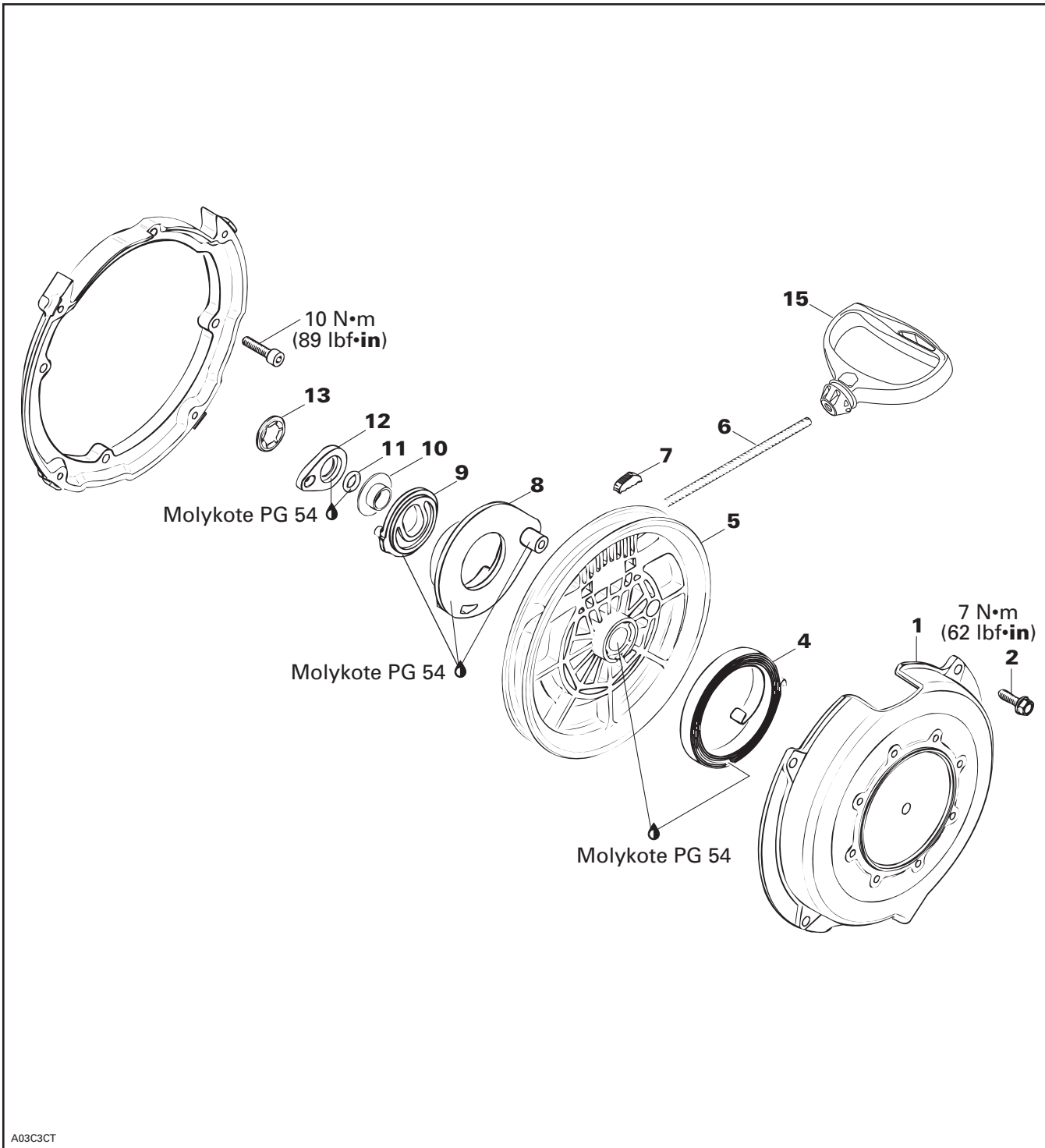

INSPECTION

NOTE: Due to dust accumulation, rewind starter must be periodically cleaned, inspected and lubricated.

CAUTION: It is of the utmost importance that the rewind starter spring be lubricated periodically using specific lubricant. Otherwise, rewind starter component life will be shortened and/or rewind starter will not operate properly under very cold temperatures.

Check if rope no. 6 is fraying, replace if so.

When pulling starter grip, mechanism must engage within 30 cm (1 ft) of rope pulled. If not, disassemble rewind starter, clean and check for damaged plastic parts. Replace as required, lubricate, reassemble and recheck. Always replace O-ring no. 11 every time rewind starter is disassemble.

When releasing starter grip, it must return to its stopper and stay against it. If not, check for proper spring preload or damages. Readjust or replace as required.

When pulling starter grip 10 times in a row, it must return freely. If not, check for damaged parts or lack of lubrication. Replace parts or lubricate accordingly.

REMOVAL

Using a small screwdriver, extract rope knot from starter grip no. 15. Cut rope close to knot. Tie a knot near starter.

Remove screws no. 2 securing rewind starter no. 1 to engine then remove rewind starter.

Fan Cooled Engines Only

Remove pump from rewind starter cover.

ROPE REPLACEMENT

Completely pull out rope. Hold rewind starter in a vise.

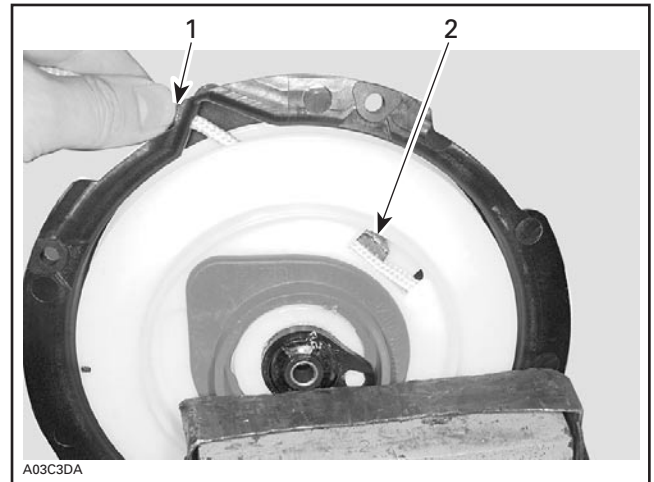

1. Rope exit hole
2. Key to be removed

With a long thin pin punch inserted through rope exit hole, push key no. 7. Remove key and rope. Install a new rope and lock it using key no. 7.

NOTE: When rope is completely pulled out, spring preload is 4-1/2 turns.

DISASSEMBLY

Undo knot previously tied at removal. Let sheave get free to release spring preload.

Cut push nut no. 13 and discard. Remove locking element no. 12, O-ring no. 11, step collar no. 10, pawl lock no. 9 and pawl no. 8.

Remove sheave no. 5 from starter housing no. 1. Hold spring with a screwdriver.

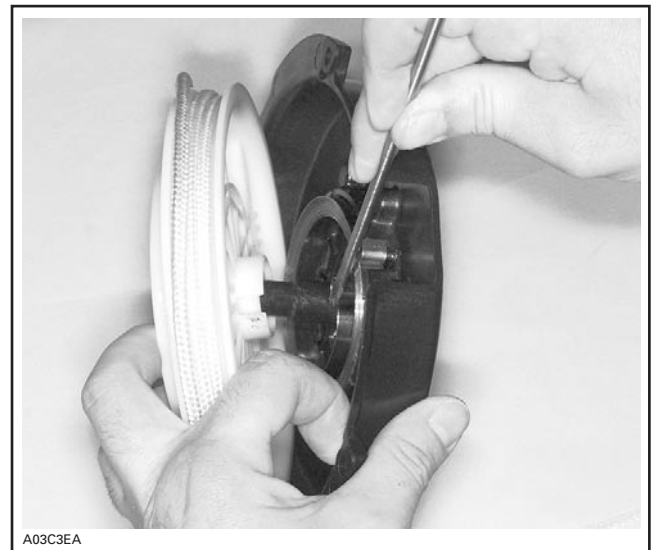

SECTION 04 - ENGINE PREPARATION

Disengage key no. 7 and pull out rope no. 6.

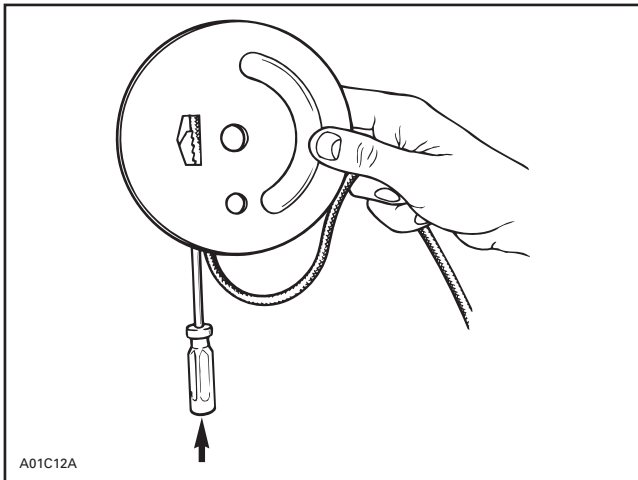

GENTLY TAP ON KEY

ASSEMBLY

At assembly, position spring no. 4 outer end into spring guide notch then wind the spring counter-clockwise into guide.

⚠ WARNING

Since the spring is tightly wound inside the guide it may fly out when rewind is handled. Always handle with care.



1. Outer end into guide notch

CAUTION: It is of the utmost importance that the rewind starter spring be lubricated periodically using specific lubricant. Otherwise, rewind starter component life will be shortened and/or rewind starter will not operate properly under very cold temperatures.

Lubricate spring assembly and 1 cm (1/2 in) wide on bottom of housing with Molykote PG 54 (P/N 420 899 763).

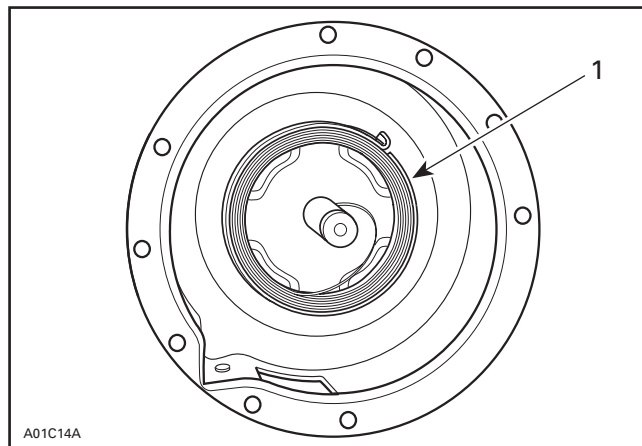

TYPICAL

1. Molykote PG 54 inside spring guide

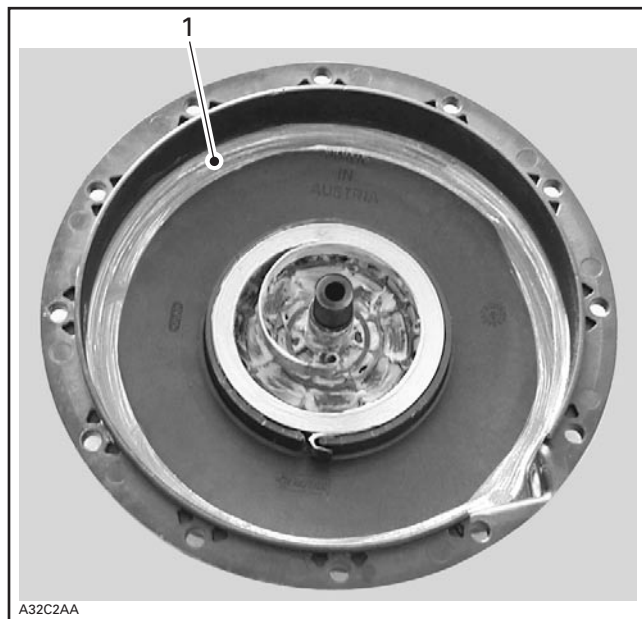

1. Molykote PG 54 applied 1 cm (1/2 in) wide on bottom of housing

CAUTION: The use of standard multi-purpose grease could result in rewind starter malfunction.

SECTION 04 - ENGINE PREPARATION

To install rope **no. 6**, insert rope into sheave **no. 5** orifice and lock it with the key **no. 7** as illustrated.

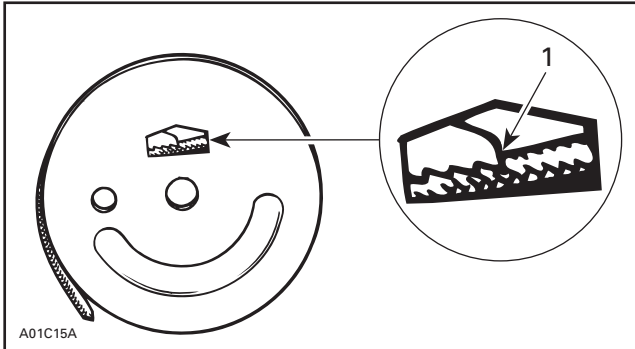

1. Push to lock

Lubricate housing post with silicone compound grease. Install sheave.

To adjust rope tension:

Wind rope on sheave and place rope sheave into starter housing making sure that the sheave hub notch engages in the rewind spring hook.

Rotate the sheave counterclockwise until rope end is accessible through rope exit hole. This will give 1/2 turn of preload.

Pull the rope out of the starter housing and temporarily make a knot to hold it.

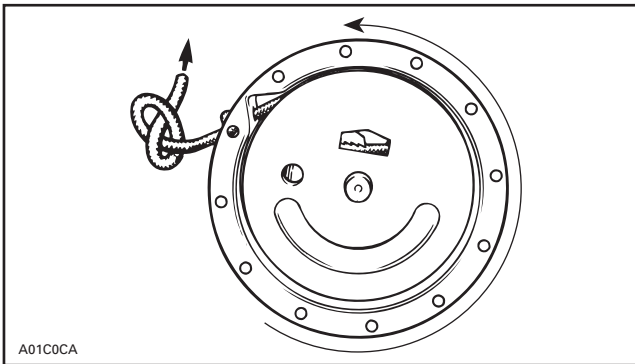

TYPICAL

Lubricate pawl **no. 8** with Molykote PG 54 (P/N 420 899 763) then install over rope sheave.



Lubricate pawl lock **no. 9** with Molykote PG 54 (P/N 420 899 763). Install over pawl.

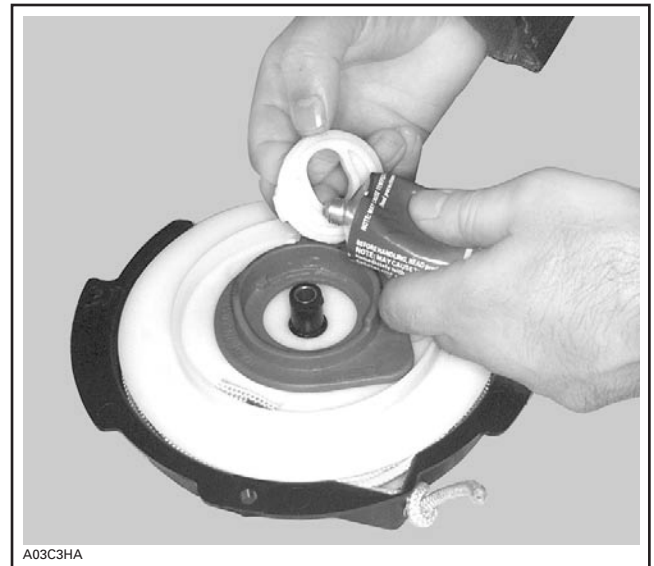

SECTION 04 - ENGINE PREPARATION

Install step collar no. 10 with its sleeve first. Lubricate a new O-ring no. 11 and locking element no. 9 with Molykote PG 54 (P/N 420 899 763). Install over pawl lock.

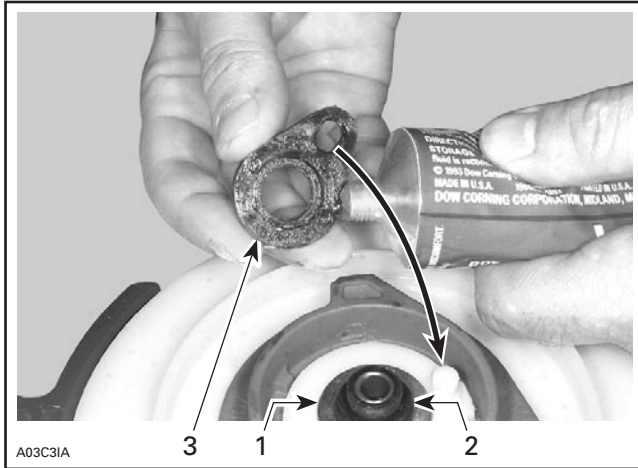

1. Step collar
2. O-ring
3. Locking element

Position a new push nut no. 13.

INSTALLATION

Fan Cooled Engines Only

Reinstall oil pump on rewind starter assembly.

All Models

Thread starter rope no. 6 through rope guide when applicable.

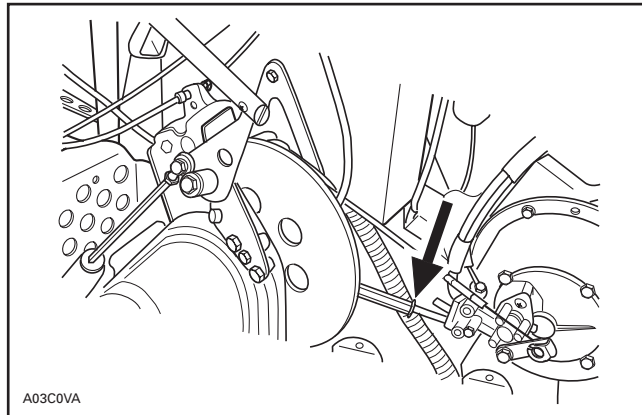

A03C0VA

TYPICAL

Reinstall rewind starter assembly on engine.

Prior to installing starter grip no. 15 on new rope, it is first necessary to fuse the rope end with a lit match. Pass rope through starter grip and tie a knot in the rope end. Fuse the knot with a lit match then insert rope end down and pull the starter grip over the knot.

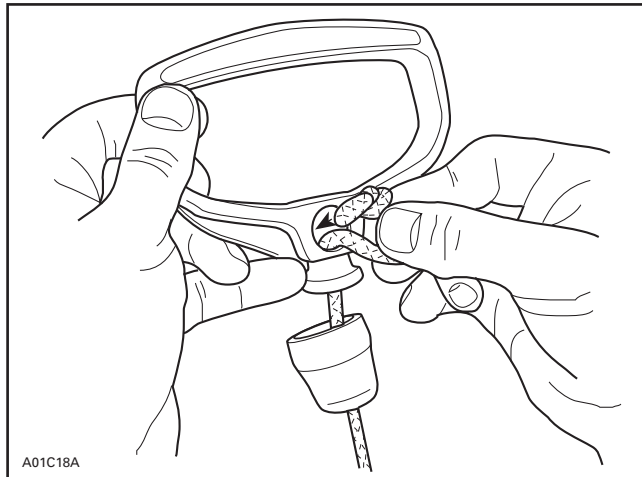

A01C18A

TYPICAL

TABLE OF CONTENTS

BASIC FUNCTIONS OF THE SYSTEM 05-2

EFFECTS OF THE DRIVE PULLEY LEVER ARM, ROLLER AND ROLLER PIN WEIGHT 05-3

EFFECTS OF THE RAMP PROFILE ON THE SHIFT FORCE 05-6

DRIVE PULLEY 05-9

INSTRUCTION 05-9

DISASSEMBLY 05-9

CLEANING (IF REQUIRED) 05-10

ASSEMBLY 05-11

INSTALLATION 05-13

DRIVE PULLEY ADJUSTMENT 05-14

PULLEY DISTANCE AND ALIGNMENT 05-15

 GENERAL 05-15

 GENERAL PROCEDURE 05-15

 PULLEY ALIGNMENT AND DISTANCE SPECIFICATIONS CHART 05-16

TRA & TRA 3 DRIVE CLUTCH 05-17

 TRA 05-17

 TRA 3 05-17

 VSA 05-17

 BELTS 05-17

 TUNING COMPONENTS 05-18

 CLUTCH ALIGNMENT 05-18

 RAMP CHARACTERISTICS 05-19

 TRA RAMP PROFILES 05-20

 EFFECTS OF THE DRIVE PULLEY SPRING 05-25

 TRA SPRINGS CHART 05-28

 EFFECTS OF THE DRIVEN PULLEY SPRING 05-30

 EFFECTS OF THE DRIVEN PULLEY CAM 05-31

 DRIVEN CLUTCH CAMS 05-33

 DRIVE BELTS 05-34

 CHAINCASE GEARING 05-36

 TRANSMISSION CALIBRATION PROCEDURE 05-39

 TRANSMISSION TUNING TEST SHEET 05-40

 RACERS LOG 05-41

BASIC FUNCTIONS OF THE SYSTEM

The TRA Clutch

We call it a clutch but that set of pulleys is a lot more than simply a clutch. Once the system reaches its low ratio speed, the clutch function ends and the pulleys become a completely automatic transmission searching for the highest gear ratio that can be pulled at the engine's given output. In the case of our TRA clutch, the pulleys will begin shifting from a 3.8:1 ratio in low gear to a .8:1 overdrive ratio in high gear. That is a lot of ratio change. A typical six-speed motorcycle gearbox, for instance, will change from a 2.38:1 ratio in low gear to a .96:1 overdrive ratio in high gear.

The ratio changing is done by opening and closing a drive and driven pulley and forcing a fixed length drive belt to turn around different diameters on each pulley. The force used to **close** the engine or drive pulley is centrifugal force. It is the job of the ramps, rollers and lever arms to convert and control the centrifugal force.

Each engine will produce its maximum horsepower at a particular RPM. Power will decrease at engine speeds on either side of the peak power RPM. The usable width of the power band will dictate where the clutch must be calibrated to keep the engine performing at its peak. In the power curve the mildly-tuned engine has its peak horsepower of 64 at 5800 RPM and has a usable power band width of 1500 RPM. The race tuned engine produces its peak of 92 horsepower at 9300 RPM, but only has a usable power band width of 400 RPM. The race engine will have to have a much more accurately calibrated clutch to be able to keep the engine running within a 400 RPM range compared to the 1500 RPM wide range of the mildly-tuned engine.

The goal of clutch calibration is to keep the engine, at full throttle at its peak horsepower RPM and, at the same time, to select the highest possible gear ratio as dictated by the load on the drive axle. The speed diagram illustrates what the goal of good clutch calibration is.

In the speed diagram, the inclined line labelled low ratio indicates the vehicle speed at each RPM when locked into the 3.8:1, low gear ratio. At 8000 RPM, the vehicle speed would be just under 20 MPH if held in this ratio. The high ratio line compares vehicle speed with engine RPM when the transmission is locked into the .8 :1 high gear. At this ratio, the vehicle speed would be just under 80 MPH when the engine is turning 8000 RPM. In calibrating the clutches, the objective will be to maintain as horizontal a line as possible between the low ratio and high ratio lines. This transition line or shift speed must be as close as possible to the engine peak horsepower RPM.

Engagement speed of the clutch is always set as **low** as possible to avoid track slippage and to prolong drive belt life. The clutch must be engaged at an RPM that is high enough, however, that the engine will be producing enough horsepower to overcome drag and allow acceleration without bogging. In the speed diagram, the acceleration period between 0 and about 20 MPH illustrates the actual clutching period of the transmission. During this time the rollers in the clutch are on the initial angles of the clutch ramps and the drive belt is actually slipping in the engine pulley as engine and vehicle speeds increase to about 9000 RPM at 25 MPH. The transmission then begins upshifting to the high ratio at a constant engine RPM. Engine speed should not increase above the calibration RPM until the high ratio is achieved. If the engine RPM exceeds the calibration RPM once the high gear position is achieved, it is an indication that the chaincase gearing is too low. If clutch calibration is accurate, engine speed should never vary more than 50 RPM from the peak power RPM. This is the optimum shift curve.

The following section will discuss each of the tunable components of both the drive and driven pulleys and provides some insight and data necessary for tuning the system.

POWER CURVES MILDLY TUNED VS. RACE TUNED

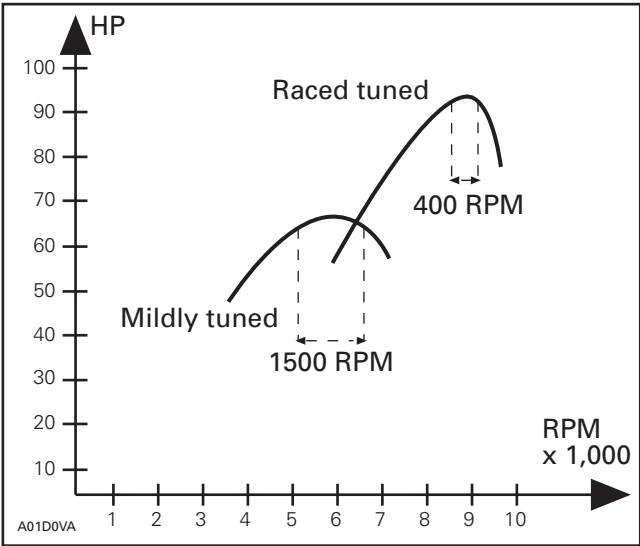

SPEED DIAGRAM ENGINE SPEED VS. VEHICLE SPEED

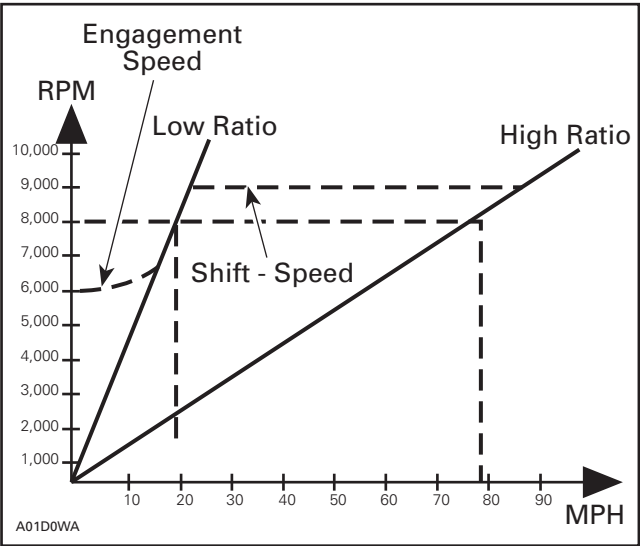

EFFECTS OF THE DRIVE PULLEY LEVER ARM, ROLLER AND ROLLER PIN WEIGHT

As you have seen in the formula defining centrifugal force, the force increases directly with the weight of the components involved. If you want to increase the centrifugal force, therefore, the shift force, it is a simple matter to increase the weight of the pressure levers. If the overall RPM is too high, a heavier lever arm or roller pin could be installed. The opposite would apply if the RPM is too low.

The major factor controlling centrifugal force is engine RPM. Because the force increases with the square of this speed, you can quickly have too much force if heavy weights are used on a clutch fitted to a high RPM engine. Because of this relationship, you will find heavy weights used on low RPM, high torque engine types and much lighter weights used on the high RPM engines.

The effect of the weights will always be greater at high RPM, and at higher ratios. This is true because of the relation of the force to the square of the engine speed. Also the radius from the axis of rotation to the center of mass of the counterweights increases as the roller is allowed to move down the ramps. As this radius increases, the centrifugal force increases directly. Addition of weight will affect engagement speed very little compared to the effect the weight will have at mid-range to top speed.

Minor changes in weight are accomplished by using various weight roller pins. The effects of adding weight are illustrated in the following illustration. The three curves show the engine RPM increasing from engagement speed (4000 RPM) to about 6500 RPM which is achieved at about 30 MPH. From this point on, if calibration is accurate, there is no change in engine RPM as the vehicle speed increases. From the machine standing at rest to about 30 MPH, belt slippage and other factors are involved that allow the engine to get on the power.

SECTION 05 - DRIVE SYSTEM

Curve **A** shows a clutch set up with three 10-gram type roller pins. This amount of weight will govern the engine to 7200 RPM and allow engagement of the clutch at 4000 RPM.

Curve **B** illustrates the effect of exchanging the three 10-gram pins for three 14-gram roller pins. The additional weight has virtually no effect on engagement speed but pulls the peak RPM of the engine down to 6800 RPM.

Curve **C** illustrates the effect of using three 16-gram roller pins. Again, the additional weight has little effect on the engagement RPM but further reduces the top RPM to 6400 RPM. For example, by adding 2 grams per arm for a total weight increase of 6 grams on an engine turning at around 7500 RPM, there would be about a 200 RPM decrease in full power engine speed — approximately the same effect as going 1 clicker position lower.

On a high RPM race engine it may only take a 1 gram, increase per arm to see a 200 RPM decrease in peak operating RPM.

Drive Clutch Roller Pins

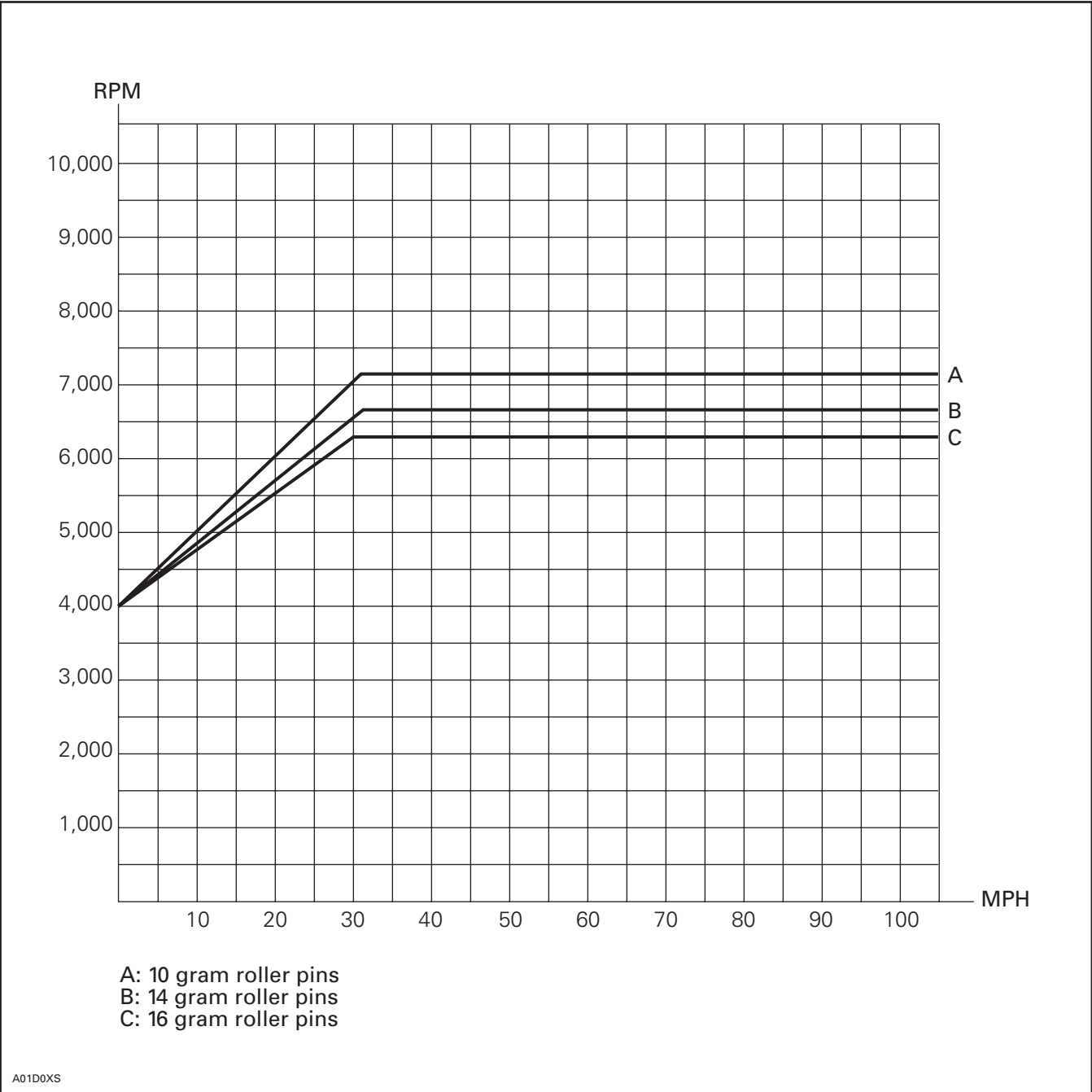

SECTION 05 - DRIVE SYSTEM

The weight of the lever arms will have a similar effect on the shift RPM. Early TRA clutches used an aluminum arm that weighed 37.9 grams. Starting in 1993, a heavier, reinforced aluminum arm was used on larger engine types. This heavier arm is now standard in all TRA clutches. It weighs 39.1 grams. Most of the reinforcing is concentrated at the pivot end of the arm, so the additional weight does not have a major effect on the shift curve, but changing from light aluminum arms to heavy aluminum arms will require small adjustments to the pin weight to obtain the same shift curve. A magnesium arm is also available (P/N 417 003 802) which weighs 27.3 grams.

The location of the center of gravity of the lever arm assembly will also affect the shift curve. Magnesium arms with solid steel pins will feel different than aluminum arms with threaded aluminum pins with 1 set screw. Both of these combinations have a total weight within 0.1 gram of each other, but the center of gravity of the magnesium arm set up is much farther away from the pivot pin than the aluminum arm set up. This magnesium arm set up will be revving higher at low ratios and part throttle openings.

By adding or removing weight to or from the arms, we can fine tune the shift RPM to the engine power peak.

If you increase the horsepower of the engine at the same RPM, you would normally add more weight to keep the engine pulling as hard as possible and not over rev.

If you lighten the weights on the arms, you will be increasing the shifting RPM. However, your vehicle will not **pull** as hard, since less centrifugal force is being generated.

This should be optimized by accurate testing under duplicatable conditions until the best weight is found for your use.

Heavy aluminum arm	39.1	417 003 801
Magnesium lever arm	27.3	417 011 012
Solid steel roller pin	16.4 (black)	504 259 600
Hollow steel roller pin	10.3	417 004 309
Threaded steel roller pin	10.3	417 222 491
Allen set screw	0.9	206 260 699
Steel roller	9.8	417 003 900
Steel roller	8.5	417 222 042
Aluminum roller	4.1	860 411 800 (kit)

EFFECTS OF THE RAMP PROFILE ON THE SHIFT FORCE

The shift force is the component or part of the centrifugal force that is used to actually move the sliding half of the drive pulley. This force is applied to the sliding half at the three lever arm pivot points (following illustration item 49). The ramp profiles are used to control the size of this shift force.

As the clutch rotates around the center line of the crankshaft, the axis of rotation, centrifugal forces begin building and act on the center of mass of the lever arm, roller combination trying to pull the lever away from the axis of rotation. The center of mass of the lever arm assembly is the point where all the centrifugal force acts (following illustration item 70).

The ramp provides an angled surface for the roller to push against and the angle of the ramp at the point of contact with the roller determines how much of the centrifugal force is translated into axial force. The axial force pushes the sliding half in and the remainder of the centrifugal force is unused and absorbed by the integrity of the sliding half. A steeper ramp angle gives less shift force, while a smaller angle gives more shift force.

As you can see in following illustration, the angle of the ramp varies constantly from start to finish. The angle varies to achieve the proper axial force to transmit a given amount of torque through the drive belt at each diameter of the pulley.

As discussed before, the centrifugal force generated by the lever arm assembly increases at higher ratios. This is why the ramp profile is much steeper at the high ratio end. This reduces the shift force in order to maintain the correct load on the belt.

Remember, it is the angle of the ramp at the point of roller contact that will help determine the shift force at any given ratio. Think of the ramp profile as a hill that the roller must climb. A small angle or hill can be overcome easily thus providing a faster shift out to a higher ratio which will lower the engine RPM. If the hill is steeper (the ramp angle is larger) the roller will not be able to climb it as quickly thus staying in a lower ratio longer which will keep the engine RPM higher.

Note that at engagement and very low ratios, many ramp angles actually go downhill. These are generally used on engines with good low RPM power. Engines with narrower power bands and less low RPM power will usually have a flatter angle at engagement and low speed. A ramp with a small bump at engagement is used to raise the engagement RPM. Again, the steeper the "hill" the roller must overcome, the higher the RPM will be before the clutch shifts out. If the spring selection cannot give the desired engagement RPM, then use a ramp with a bump or grind a notch at the point where the roller sits at engagement. Of course if the shift profile was good at higher ratios, then you would want to use a ramp with only changes at the low speed area.

Also, a thicker or taller ramp will provide higher RPM than a thinner ramp with the same profile because the lever arm assembly is tucked in further by the taller ramp.

The TRA clutch allows you to fine tune the ramp profile by using the adjusters provided. The adjusters are cams which allow you to raise and lower the outer end of the ramp through six different positions. Moving the ramp end toward the lever arm makes the ramp angles steeper, thereby raising engine speed and slowing the upshift. As the ramp is adjusted away from the lever arm, the engine speed is lowered and the upshift is faster.

In clinical condition such as on a dynamometer, moving the adjusters up will result in a 150 to 200 RPM increase with each position change. Lowering the adjuster positions will result in a decrease of 150 to 200 RPM with each number. On the snowmobile, however, depending on the operating conditions, a change of one adjuster position may not show up on the tachometer, but the shift speed of the pulley will have changed. The upshift or downshift, depending on which way you moved the adjusters, will be faster and your acceleration rate and top speed will have changed. When using the TRA adjusters, the acceleration rate and speed should be checked as well as the engine RPM.

SECTION 05 - DRIVE SYSTEM

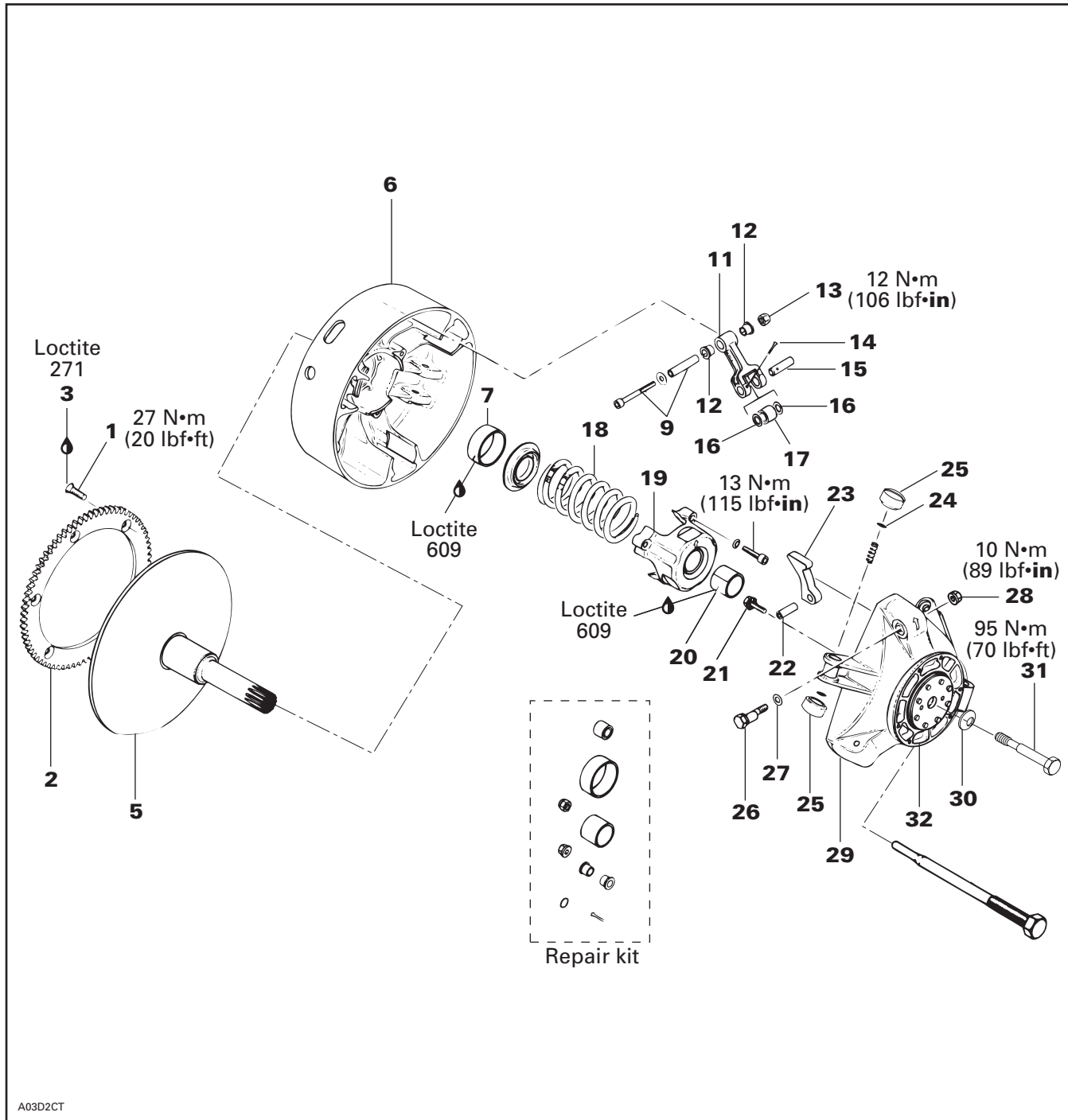

For drag racing and radar running, it is usually better to try to go as low as possible on the adjusters without dropping the engine peak RPM too much as this will give the vehicle its fastest acceleration and top speed.

For oval racing or tight snowcross type courses, you may find you need to be one or two numbers higher on your TRA adjuster to give the best throttle response possible out of the corners.

This will be where the winners spend their time testing different combinations of lever arm weights, TRA adjustments, and ramp profiles until they find the best possible setup.

DRIVE PULLEY

This instruction sheet applies to the MX Zx 440 LC only.

INSTRUCTION

Remove belt guard and drive belt.
Use holder (P/N 529 006 400).

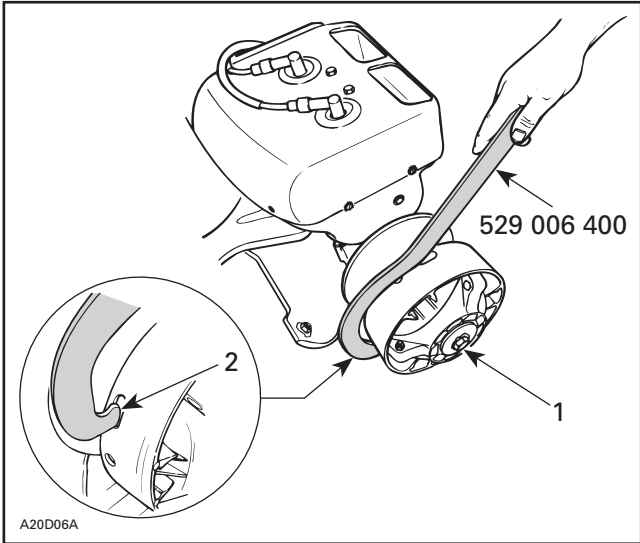

TYPICAL
1. Retaining screw
2. Insert in any slot

⚠ WARNING
Never use any type of impact wrench at drive pulley removal and installation.

Remove retaining screw.
To remove drive pulley ass’y and/or fixed half from engine, use puller (P/N 529 022 400).

CAUTION: These pulleys have metric threads. Do not use imperial threads puller. Always tighten puller by hand to ensure that the drive pulley has the same type of threads (metric vs imperial) prior to fully tightening.

To Remove Drive Pulley Ass’y:
Retain drive pulley with clutch holder.
Install puller in pulley shaft then tighten.

DISASSEMBLY

Fixed and Sliding Half

CAUTION: Do not tap on governor cup.

Screw puller into fixed half shaft about 13 mm (1/2 in). Raise drive pulley and hold it by the sliding half while knocking on puller head to disengage fixed half.

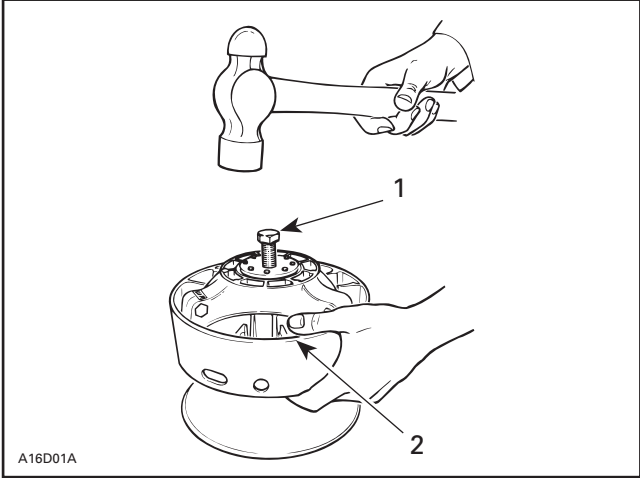

1. Puller
2. Holding sliding half

NOTE: No components marking is required before disassembling this drive pulley since it has factory mark and arrows as indexing reference.

Cushion Drive

CAUTION: Do not disassemble cushion drive. Governor cup and cushion drive are factory balanced as an assembly.

Slider Shoe and Governor Cup

Carefully lift governor cup until slider shoes come at their highest position into guides.
Hold a slider shoe set then carefully lift its housing and remove slider shoes. Proceed the same way for other housings lifting one at a time.

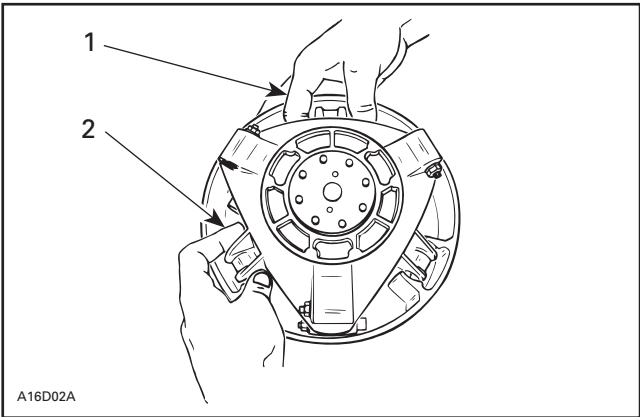

1. Hold slider shoes
2. Lift one housing at a time

SECTION 05 - DRIVE SYSTEM

NOTE: To ease disassembly, forks (P/N 529 005 500) should be used to hold slider shoes prior to removing governor cup.

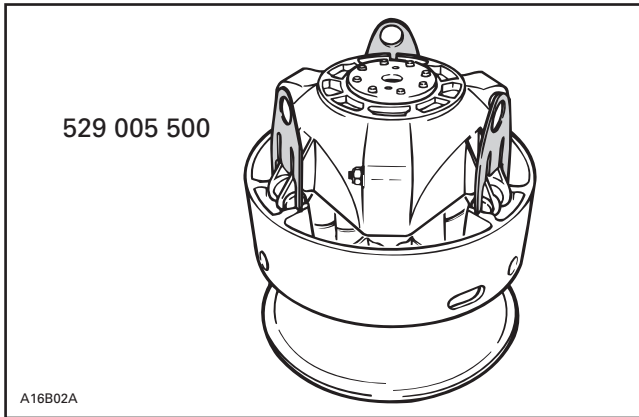

Spring Cover Ass'y

It is pushed by clutch spring pressure.

⚠ WARNING

Clutch spring is very strong. Never attempt to remove spring cover without the recommended tools.

Use spring compressor (P/N 529 035 524).
Install support guide.

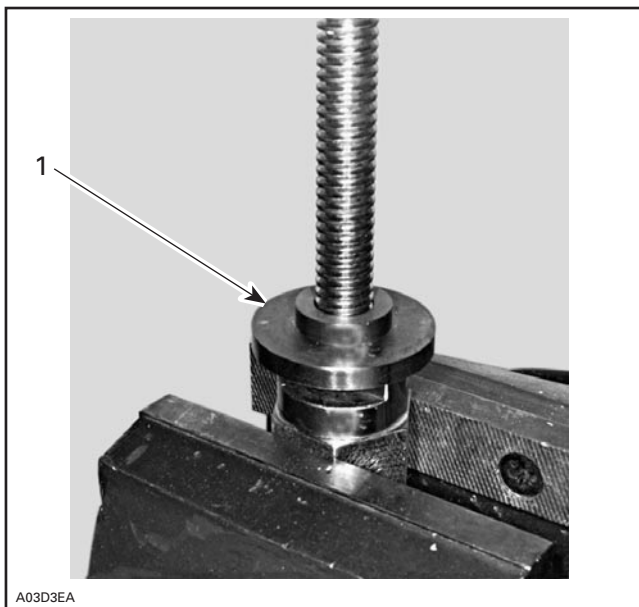

1. Support guide

Install sliding half then a second support guide.
These support guides will prevent bushing damages.

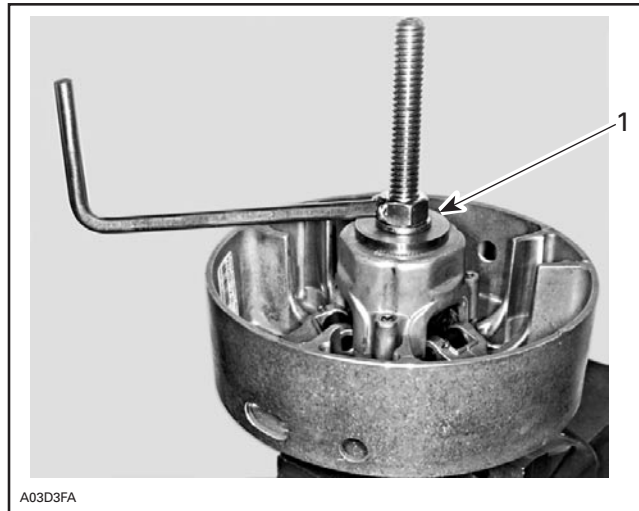

1. Support guide

Remove 3 Allen screws retaining spring cover then unscrew compressor.

CLEANING (IF REQUIRED)

Fixed and Sliding Half

Clean pulley faces and shaft with fine steel wool and dry cloth.

Fixed Half and Crankshaft End

Parts must be at room temperature before cleaning.
Using a paper towel with cleaning solvent, clean crankshaft tapered end and the taper inside the fixed half of the drive pulley, crankshaft threads and retaining screw threads.

⚠ WARNING

This procedure must be performed in a well-ventilated area.

CAUTION: Avoid contact between cleaner and crankshaft seal because damage may occur.

Remove all hardened oil deposits that have baked on crankshaft and pulley tapered surfaces with coarse or medium steel wool and/or sand paper no. 600.

CAUTION: Do not use any other type of abrasive.
Reclean mounting surfaces with paper towel and cleaning solvent.

Wipe off the mounting surfaces with a clean, dry paper towel.

CAUTION: Mounting surfaces must be free of any oil, cleaner or towel residue.

Bushing

Only use petrol base cleaner when cleaning bushings.

CAUTION: Do not use acetone to clean bushing.

Thrust Washer and Roller

Check roller for roundness of external diameter. Check thrust washer for thickness wear. Replace as required.

CAUTION: Ensure rollers are in good condition. Replace as required.

Fitting Bolt Ass’y and Flanged Bushing

Check for wear, replace as required.

O-Ring and Slider Shoe

Check if O-rings are cracked, cut or crushed. Replace as required.

Check slider shoes for wear. Replace if groove is not apparent on top.

Fixed Half and Governor Cup

Inspect splines and free play between both parts. Maximum free play is 0.5 mm (.020 in) measured at calibration screw radius. Replace if required.

Sliding Half and Spring Cover Bushing

Visually inspect coating. Replace if worn.

Sliding Half Bushing Replacement

This bushing is not replaceable. If worn out, replace sliding half ass’y.

Spring Cover Bushing Replacement

Under normal use there is no need to replace this bushing.

This bushing is not replaceable. If worn out, replace spring cover ass’y.

ASSEMBLY

NOTE: This drive pulley is lubrication free. Do not lubricate any component.

Calibration Screw, Washer and Locking Nut

When installing calibration screw, make sure to install washer as shown.

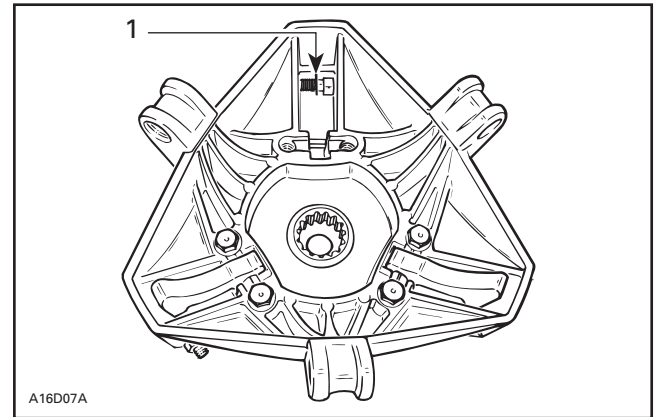

A16D07A

1. Washer

Torque locking nut to 10 N•m (89 lbf•in).

Pin

Always use the same type of pin as originally installed when servicing. Different types have different weights for calibration purpose. Refer to TECHNICAL DATA where *Shop Manual* is available.

Ramp, Dowel Tube and Screw

Insert dowel tube from chamfered side. Make sure ramp is centered on dowel tube.

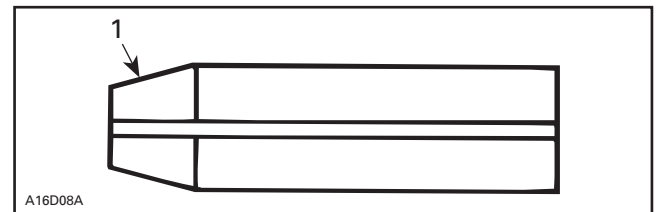

A16D08A

1. Chamfered side

Position dowel tube split at the illustrated angle.

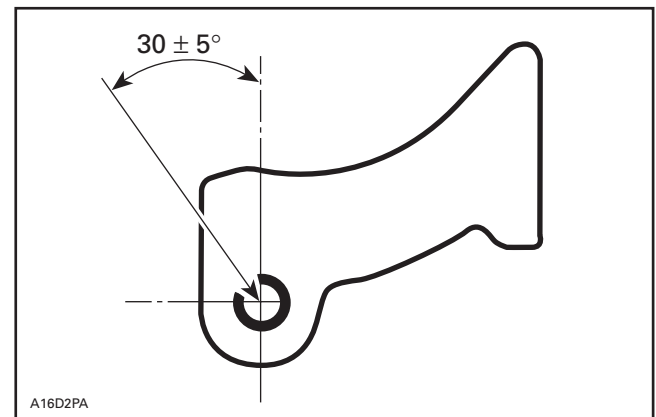

A16D2PA

SECTION 05 - DRIVE SYSTEM

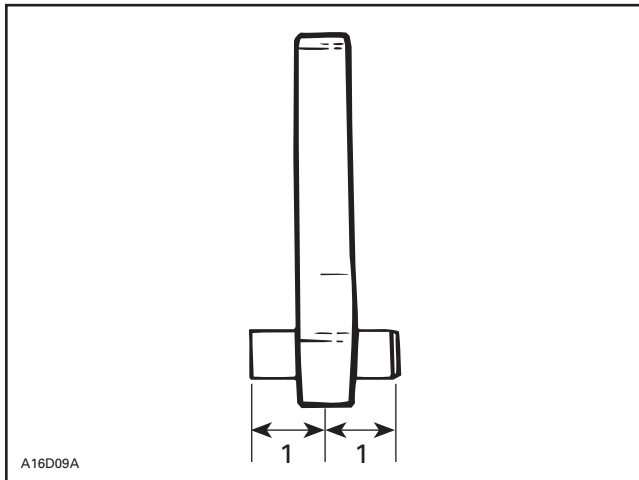

1. Equal distance

Torque screws to 10 N•m (89 lbf•in).

Screw, Lever Ass'y, Nut and Cotter Pin

Always install lever assemblies so that cotter pins are on the shown side. Besides install cotter pin head on top when lever is sat at bottom of sliding half. Bend cotter pin ends to sit perfectly against lever.

WARNING

Whenever replacing centrifugal levers, always replace all 3 at the same time. Otherwise, drive pulley misbalancing will occur because of levers difference.

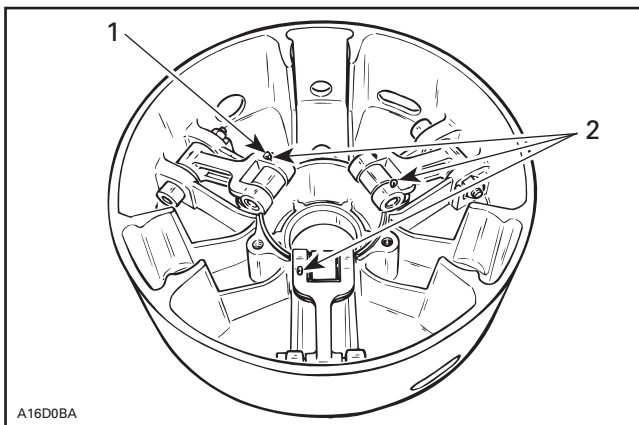

1. Head on top
2. All on the same side

CAUTION: Lever assemblies must be installed so that cotter pins are on the same side.

Torque nuts to 12 N•m (106 lbf•in).

CAUTION: Lever ass'y and rollers must move easily after installation.

Guard

Some Models Only

Install guard with its reinforcements in line with levers.

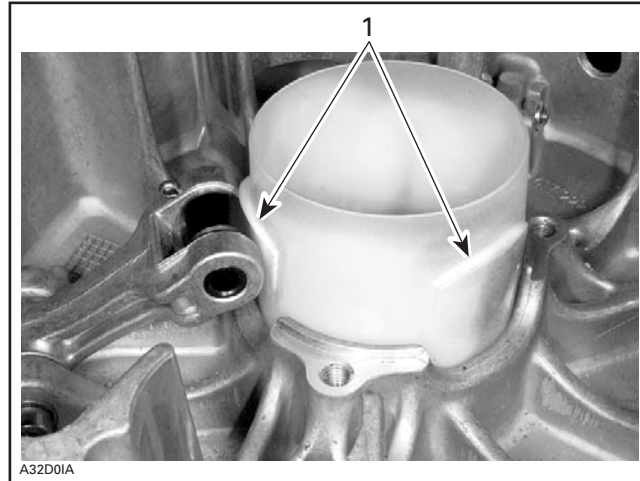

1. Reinforcements

Fixed Half, Sliding Half, Spring, Spring Cover and Screw

Install spring.

To install spring cover, use spring compressor (P/N 529 035 524). Align indexing arrows.

Assemble fixed and sliding halves.

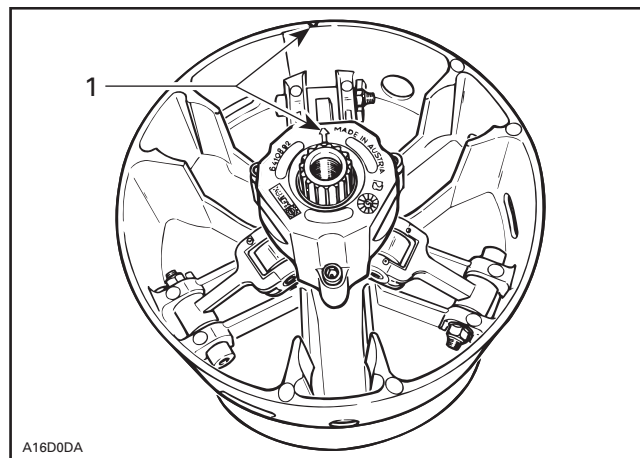

1. Align

Install and torque screws to 13 N•m (115 lbf•in) for 593 engine equipped models and to 16 N•m (142 lbf•in) for 693 and 793 engine equipped models.

Sliding Half, Slider Shoe and Governor Cup

To install governor cup, use following tool:

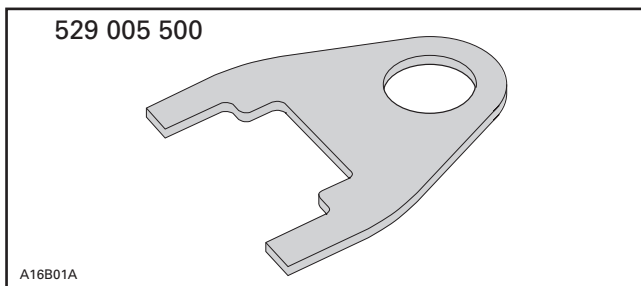

Insert spring and slider shoes into governor cup so that groove in each slider shoe is vertical to properly slide in guides.

CAUTION: Make sure O-rings are installed on slider shoes and their grooves are positioned vertically.

Install fork (P/N 529 005 500) into slider shoe grooves to maintain them for governor cup installation. Proceed on 3 set of slider shoes.

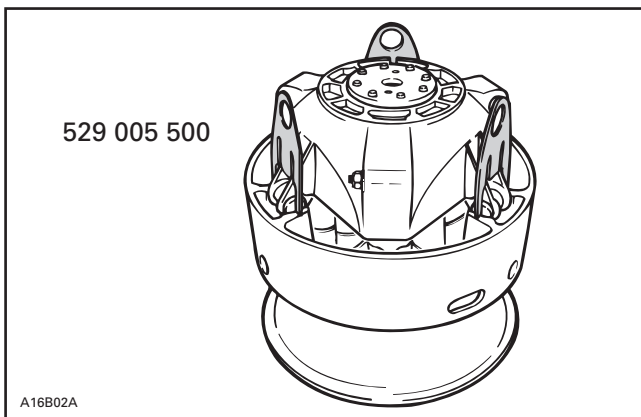

Make sure to align governor cup arrow with sliding half and fixed half mark.

NOTE: If fixed half has no mark, align governor cup mark with segment no. 1 of inner half. Segments are identified on engine side.

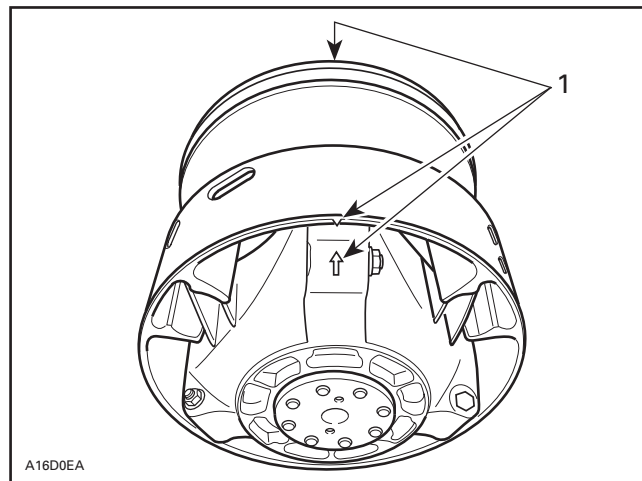

1. *Align*

Carefully slide governor cup into sliding half. Align mark of governor cup with mark of fixed half.

Remove forks and push governor cup so that its splines engage with fixed half shaft splines.

CAUTION: Make sure splines of both parts are fully engaged.

INSTALLATION

⚠ WARNING

Do not apply anti-seize or any lubricant on crankshaft and drive pulley tapers.

⚠ WARNING

Never use any type of impact wrench at drive pulley removal and installation.

Clean mounting surfaces as described in **CLEANING** above.

Drive Pulley Ass'y

The installation procedure must be strictly adhered to as follows.

Install drive pulley on crankshaft extension.

Install conical washer with its concave side towards drive pulley then install screw.

SECTION 05 - DRIVE SYSTEM

⚠ WARNING

Never substitute conical washer and/or screw with jobber ones. Always use Bombardier genuine parts for this particular case.

Use holder. See removal procedure.

Torque screw to 80 to 100 N•m (59 to 74 lbf•ft).

Install drive belt and guard.

Raise and block the rear of the vehicle and support it with a mechanical stand.

⚠ WARNING

Ensure that the track is free of particles which could be thrown out while track is rotating. Keep hands, tools, feet and clothing clear of track. Ensure nobody is standing near the vehicle.

Accelerate the vehicle at low speed (maximum 30 km/h (20 MPH) and apply the brake, repeat 5 times.

Recheck the torque of 90 to 100 N•m (66 to 74 lbf•ft).

⚠ WARNING

After 10 hours of operation the transmission system of the vehicle must be inspected to ensure the retaining screw is properly torqued.

DRIVE PULLEY ADJUSTMENT

The drive pulley is factory calibrated to transmit maximum engine power at a predefined RPM. Factors such as ambient temperature, altitude or surface condition may vary this critical engine RPM thus affecting snowmobile efficiency.

This adjustable drive pulley allows setting maximum engine RPM in the vehicle to maintain maximum power.

Calibration screws should be adjusted so that actual maximum engine RPM in vehicle matches with the maximum horsepower RPM given in TECHNICAL DATA.

NOTE: Use precision digital tachometer for engine RPM adjustment.

NOTE: The adjustment has an effect on high RPM only.

To adjust, modify ramp end position by turning calibration screws.

Calibration Screw, Locking Nut and Governor Cup

Calibration screw has a notch on top of its head.

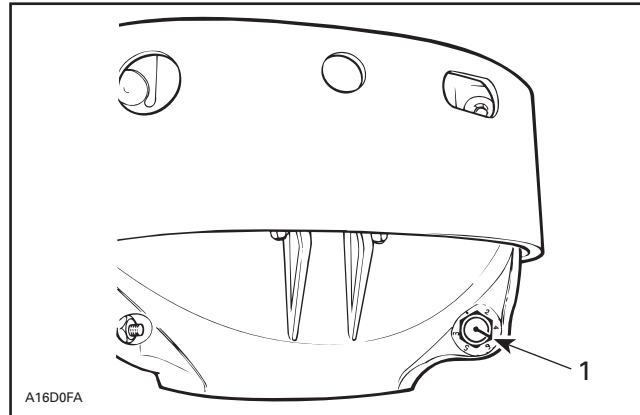

1. Notch

Governor cup has 6 positions numbered 2 to 6. Note that in position 1 there is no stamped number (due to its location on casting).

See TECHNICAL DATA for original setting where a *Shop Manual* is available.

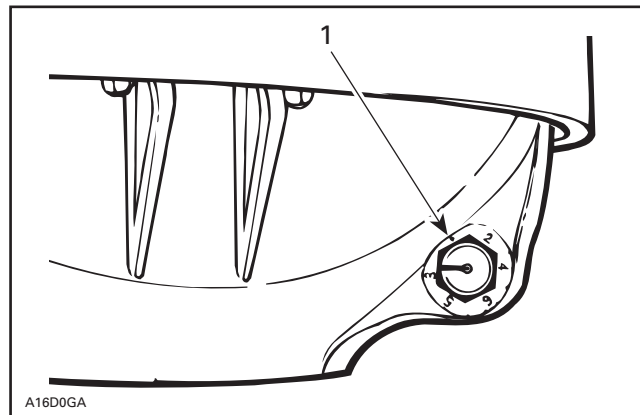

1. Position 1 (not numbered)

Each number modifies maximum engine RPM by about 200 RPM.

Lower numbers decrease engine RPM in steps of 200 RPM and higher numbers increase it in steps of 200 RPM.

Example:

Calibration screw is set at position 3 and is changed to position 5. So maximum engine RPM is increased by about 400 RPM.

To Adjust:

Just loosen locking nut enough to pull calibration screw **partially** out and adjust to desired position. Do not completely remove the locking nut. Torque locking nuts to 10 N•m (89 lbf•in).

CAUTION: Do not completely remove calibration screw otherwise its inside washer will fall off.

CAUTION: Always adjust all 3 calibration screws and make sure they are all set at the same number.

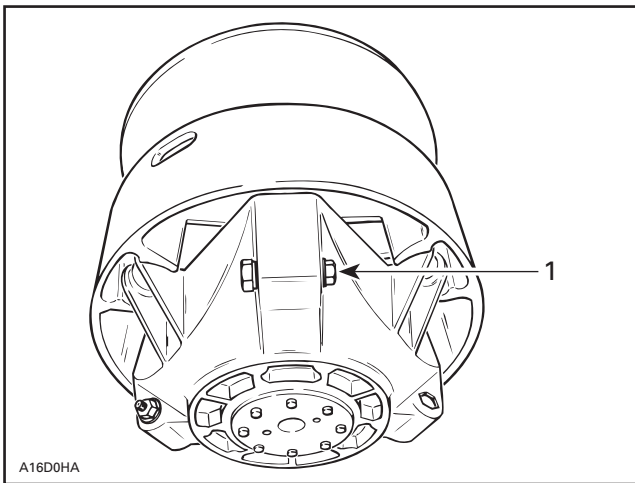

1. Loosen just enough to permit rotating of calibration screw

PULLEY DISTANCE AND ALIGNMENT

GENERAL

The pulley distance we will refer to in this section, is the space separating the drive and driven pulley outside diameters (Z measurement).

This basic distance is provided as an assembly guide and indicates the dimensions between which satisfactory belt deflection will be obtained.

Both pulley distance adjustment and pulley alignment must be carried out to ensure the highest efficiency of the transmission system. Furthermore, optimum drive belt operation and minimal wear will be obtained only with proper pulley alignment.

CAUTION: Before checking pulley adjustment, the rear suspension must be mounted on the vehicle and track tension/alignment must be done. Always check pulley adjustment after suspension is adjusted.

⚠ WARNING

Failure to correctly perform pulley alignment may cause the vehicle to creep forward at idle.

All Pulley Alignment Specifications Refer to:

X = Distance between straight bar and drive pulley fixed half edge, **measured between pulleys.**

Y = Distance between straight bar and drive pulley fixed half edge, **measured at the end of straight bar.**

Z = Distance between outside diameter of pulleys.

GENERAL PROCEDURE

Remove guard and drive belt.

By turning and pushing the sliding half, open the driven pulley. Insert a straight bar 9.5 mm (.375 in) square, 48 cm (19 in) long or the proper alignment template into the opened driven pulley.

Measuring Procedure

Using Straight Bar

Always measure distances X and Y from the farther straight bar side (including its thickness to the fixed half edge).

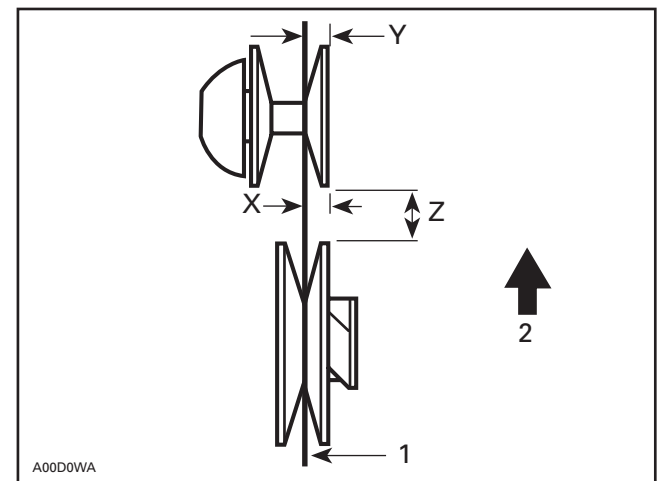

TYPICAL

- 1. Straight bar
- 2. Front of vehicle

SECTION 05 - DRIVE SYSTEM

The distance Y must exceed distance X to compensate for the twist due to the engine torque.

Drive Belt Deflection

NOTE: When pulley distance and alignment are adjusted to specifications, refer to DRIVE BELT (where a *Shop Manual* is available) to adjust drive belt deflection.

CAUTION: This section deals mainly with adjustment procedures. For complete assembly requirements, refer to the proper ENGINE or TRANSMISSION installation section.

PULLEY ALIGNMENT AND DISTANCE SPECIFICATIONS CHART

MODEL	PULLEY DISTANCE	OFFSET		ALIGNMENT TEMPLATE ① P/N
	Z	X	Y-X	
	± 0.50 mm (.020 in)	± 0.50 mm (.020 in)	± 0.50 mm (.020 in)	
MX Z	16.5 (.650)	35.50 (1.398)	1.5 (.060)	529 026 700

① Alignment templates have been made according to pulley alignment nominal values. However, they do not take into account allowed tolerances for alignment specifications. They are used as GO/NO GO gauges for quick alignment and pulley distance check and as templates to reach alignment nominal values.

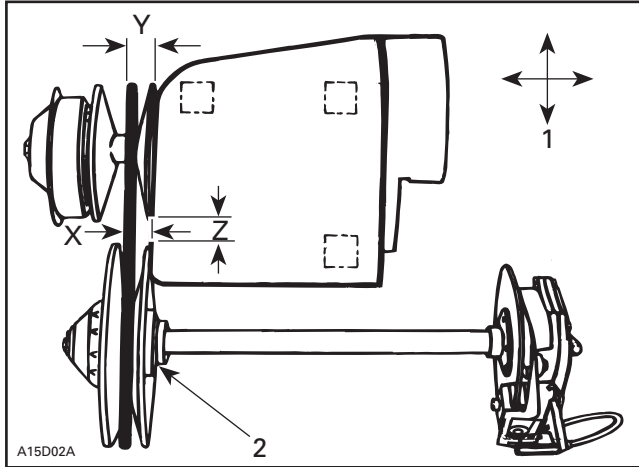

TYPICAL

1. Engine movement
2. Contact



ALIGNMENT BAR IN PULLEYS

NOTE: Prior to performing pulley adjustment, loosen torque rod nut to allow engine movement. Engine supports have tendency to stick to frame, work engine loose prior to aligning.

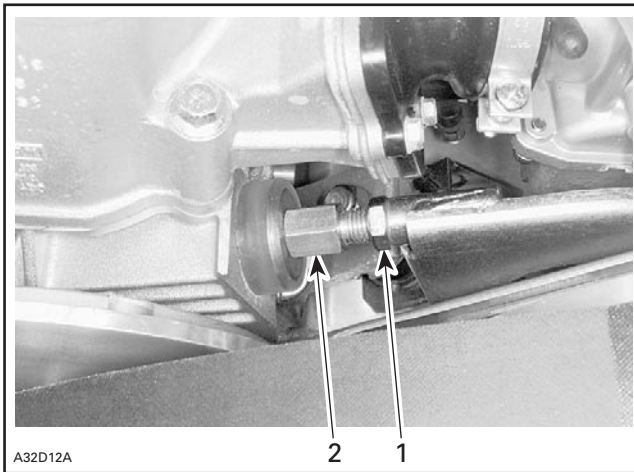

1. Loosen lock nut first
2. Loosen

Pulley Distance Adjustment Method

Engine Movement

The engine support has slotted mounting holes. Move engine to obtain specified distance between pulleys.

Pulley Alignment Method

Engine Movement

Loosen the 4 bolts retaining engine support to the frame. Position engine to obtain the specified alignment.

NOTE: After alignment, adjust torque rod so it slightly contacts stopper plate. Do not over tighten, it will disalign pulleys.

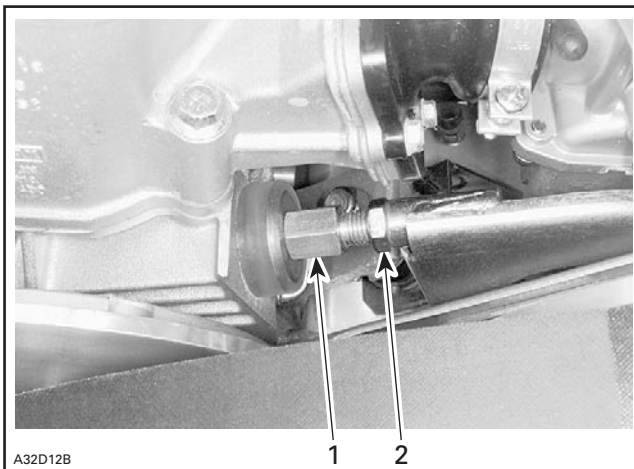

1. Slightly tighten
2. Retighten

Reinstall drive belt and belt guard.

TRA & TRA 3 DRIVE CLUTCH

TRA

Most models of 2003 Ski-Doo snowmobiles use a standard TRA drive clutch. This style of drive clutch has been used for many years and is the type most racers are familiar with. The TRA clutch is capable of using a wide variety of tuning components including ramps, arms, weighted pins, rollers, and springs. Because of the continued wide use of the style of clutch, this section of the manual will explain in detail its operation and tuning components.

TRA 3

Some 2003 models come equipped with a TRA 3 style drive clutch. They include most models with the 600 and 800 cc engines. This style of clutch is the "next" generation of engineering development from Ski-Doo and will certainly be used in more models as years go on.

Visual comparisons between the TRA and TRA 3 styles may appear slight, but in fact, there are many differences, and when you are working with it, you need to be aware of the differences.

VSA

The TRA 3 has Variable Sheave Angle (VSA). The machined angle of both sheaves varies from 12 degrees at the bottom to 14 degrees at the top. This provides better efficiency through out the entire range of shift. With the improved efficiency, belt life is also extended. The TRA 3 clutch must be matched with a VSA type driven clutch and belt to achieve maximum performance.

BELTS

There are currently 3 different belts available for the VSA style clutch system.

PART NUMBER	DESCRIPTION
417 300 197	Production 600cc models
417 300 166	Production 800cc models
486 130 047	Race Belt, Same compound as 414 860 700

SECTION 05 - DRIVE SYSTEM

TUNING COMPONENTS

As mentioned earlier, few tuning components can be interchanged between the TRA and TRA 3 clutches. Springs, rollers and some pin weights can be interchanged. Short pins can be used but not the heavy long ones, as they will cause interference. Ramps and arms cannot be interchanged. At this time, only one type of arm is available through Ski-Doo, and that is the production aluminum. However, several ramps have been developed to allow you to tune your sled. Below is a list of ramps available and how they compare to a TRA ramp.

TRA 3	PART	TRA EQUIVALENT
410	417 222 596	299
411	417 222 514	299
412	417 222 515	293
414	417 222 546	300
415	417 222 548	300 less load at beginning
417	417 222 552	293 less load at beginning
419	417 222 557	414 with engagement notch

CLUTCH ALIGNMENT

Clutch alignment for both TRA and TRA 3 systems are the same but different between types of chassis. It is critical to proper alignment that the correct tools are used. Refer to the special tool section of this manual or contact your Ski-Doo dealer for the proper tools. MXZ chassis is detailed in this section. The REV chassis is different; it is quite easy to achieve proper clutch alignment. Due to the structural design of the REV chassis and engine mounting system, the center to center (Z) distance cannot be changed. Insert the correct alignment bar into the driven clutch and measure the Y distance. Add or subtract shims behind the driven clutch to obtain correct measurement.

RAMP CHARACTERISTICS

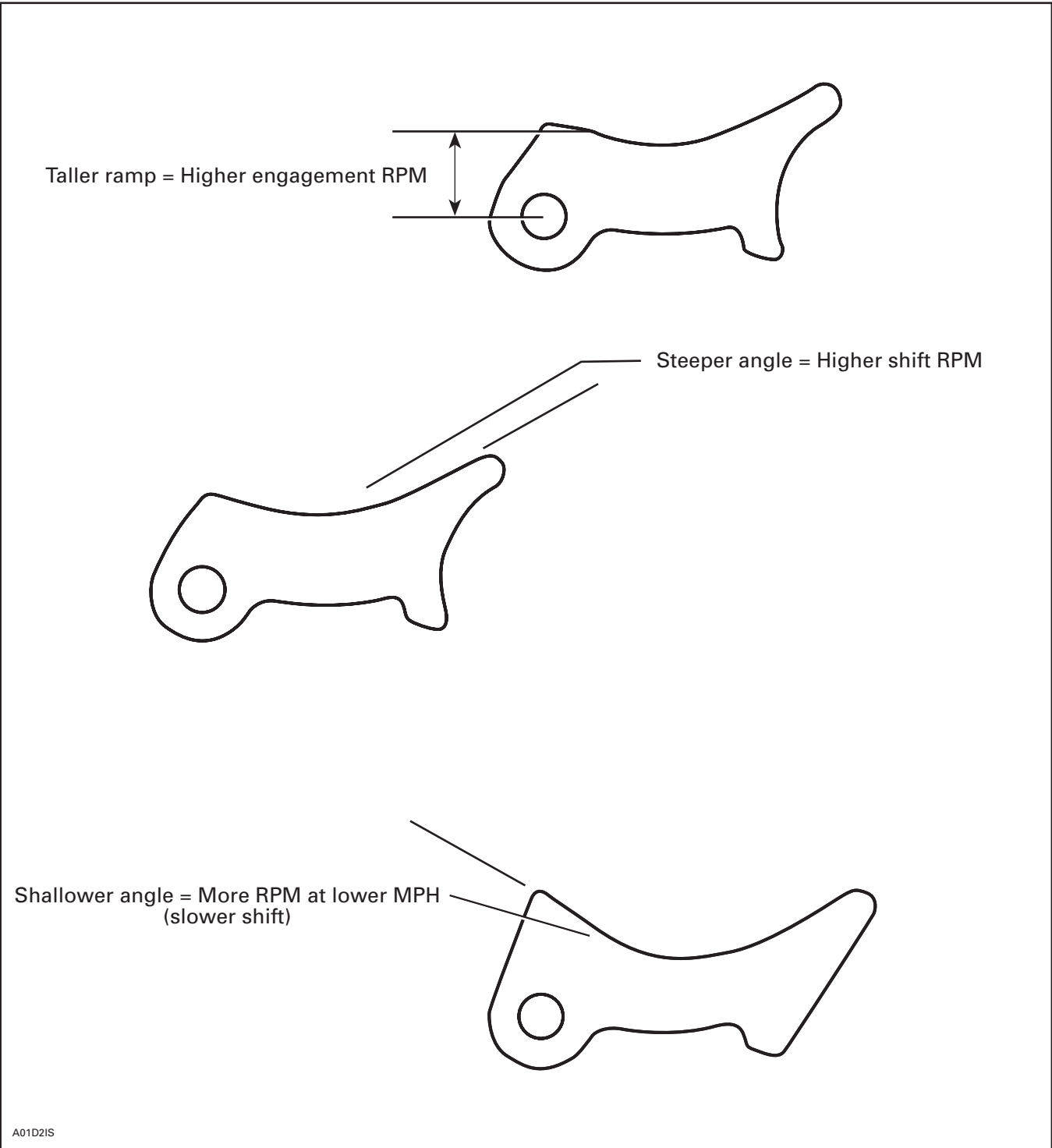

A01D2IS

SECTION 05 - DRIVE SYSTEM

TRA RAMP PROFILES

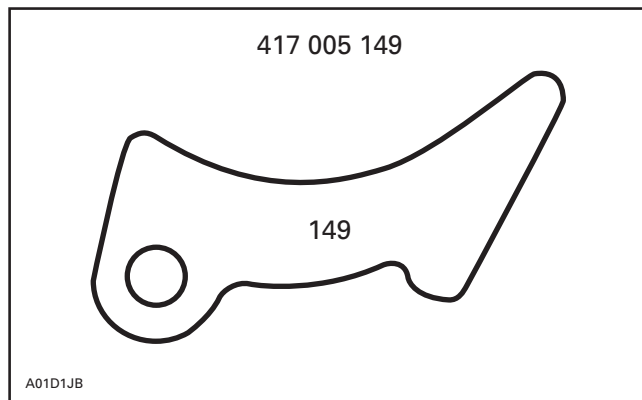
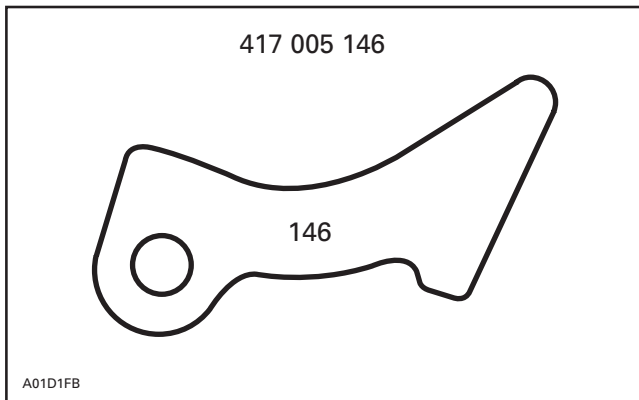
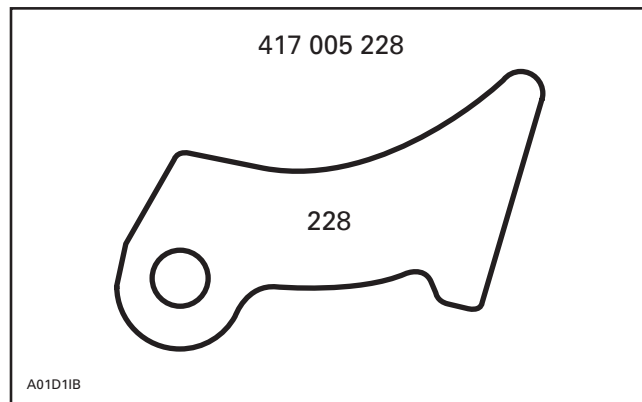
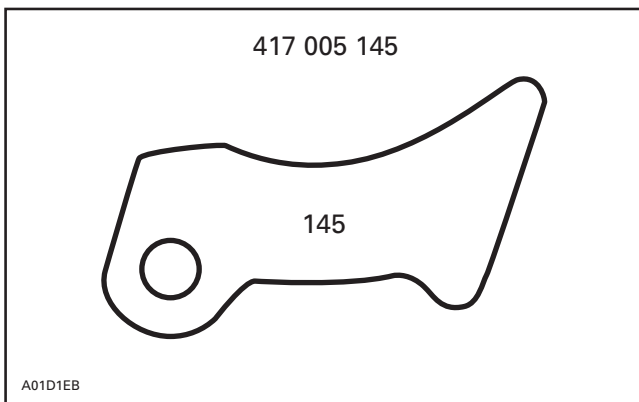
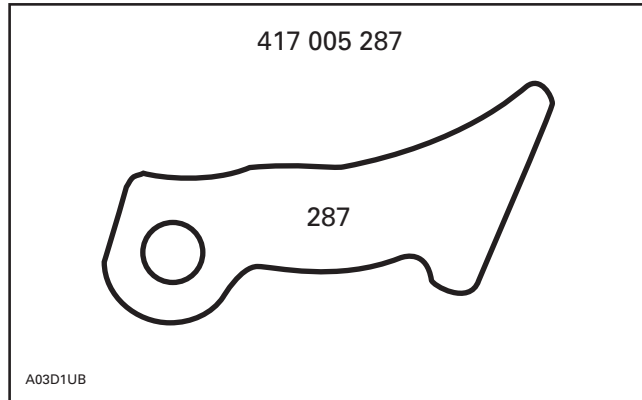
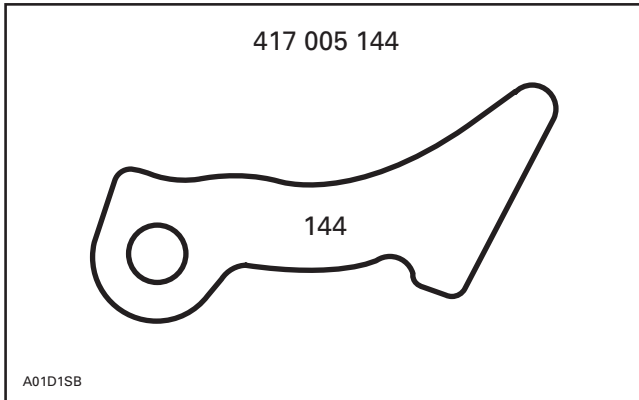

SECTION 05 - DRIVE SYSTEM

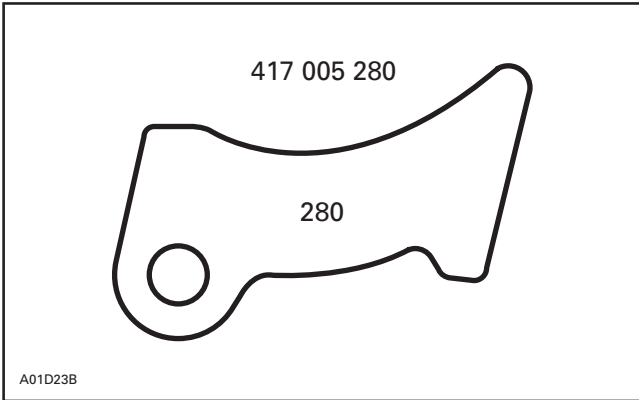
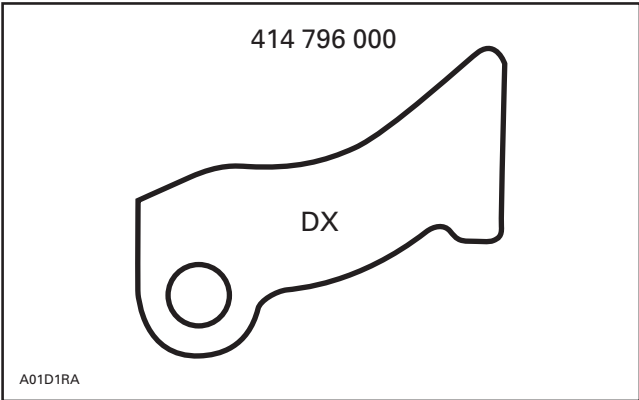
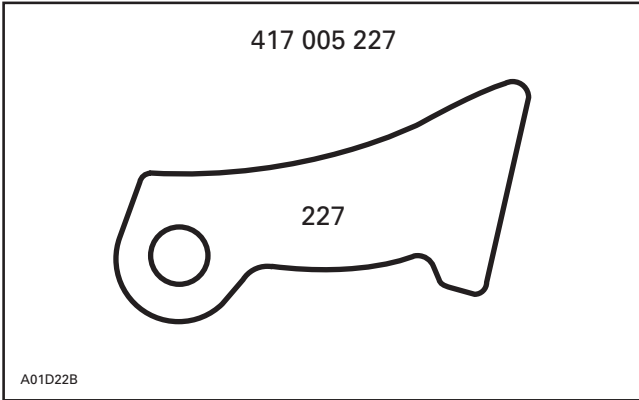
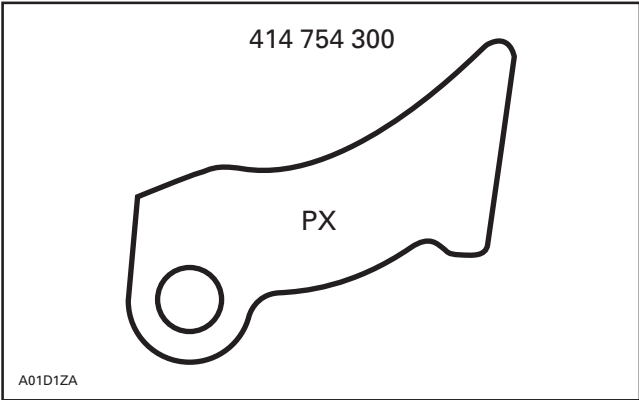
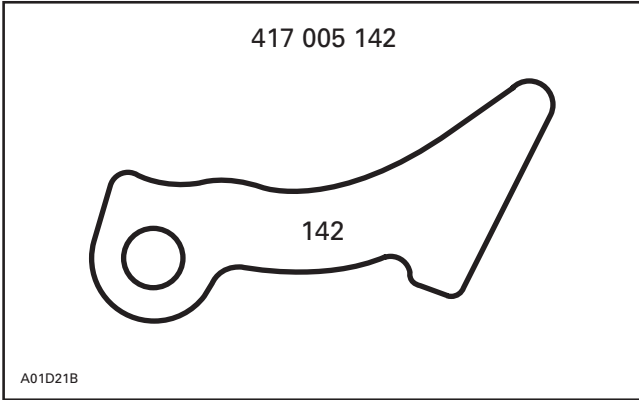
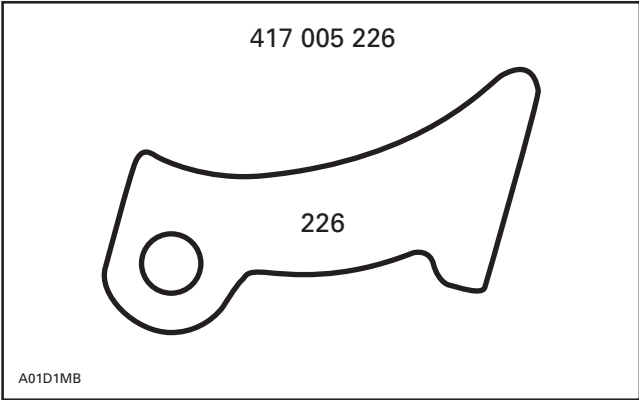
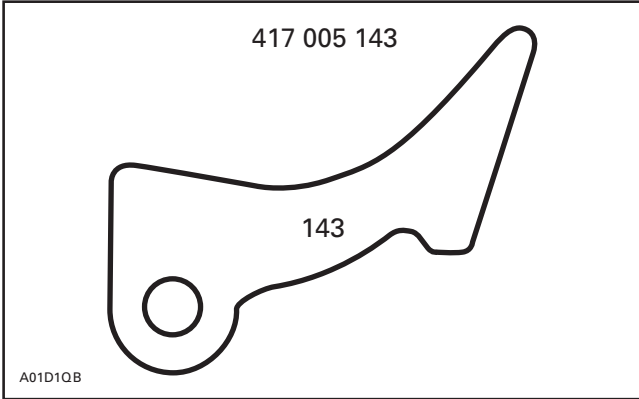
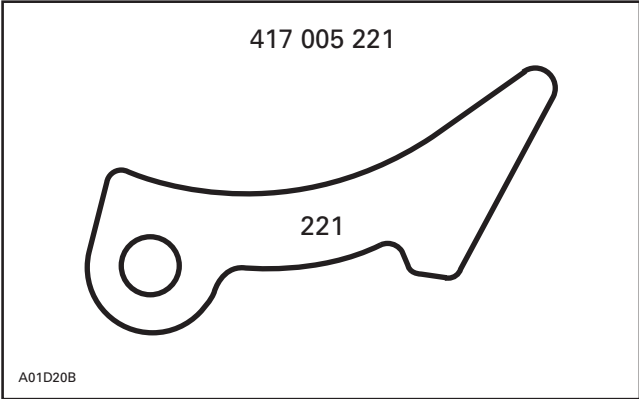

SECTION 05 - DRIVE SYSTEM

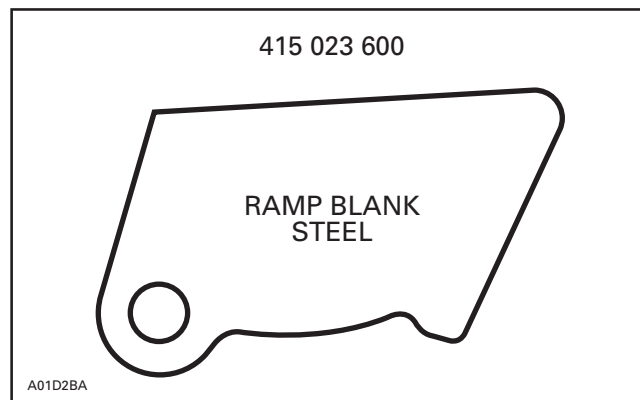
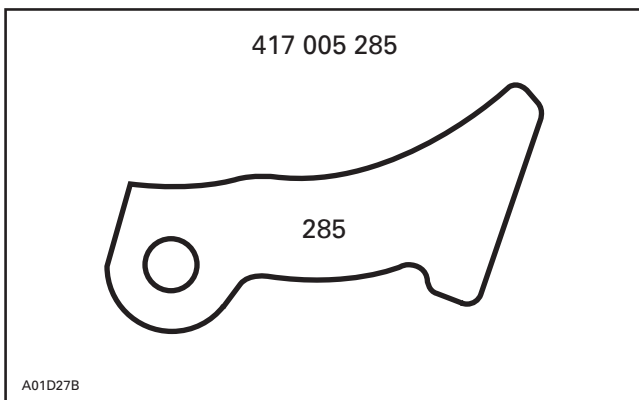
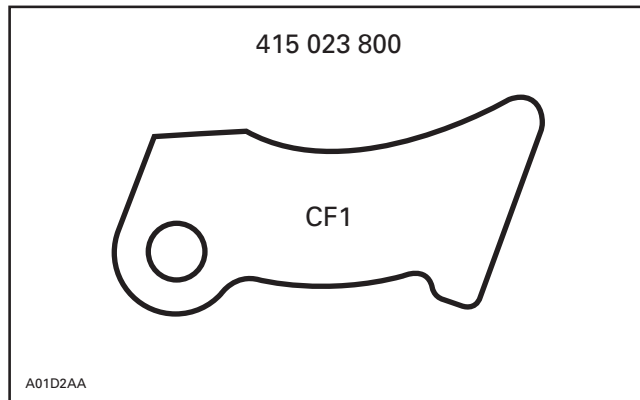
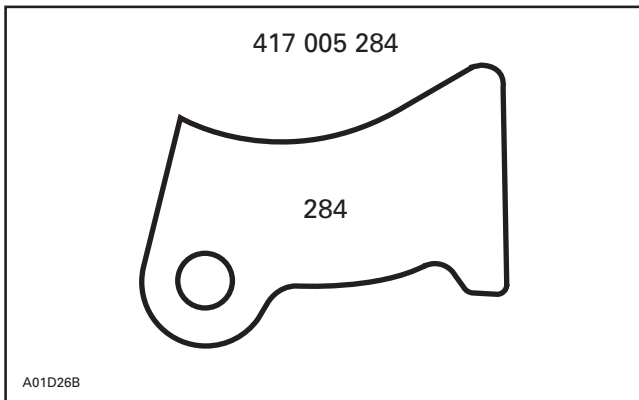
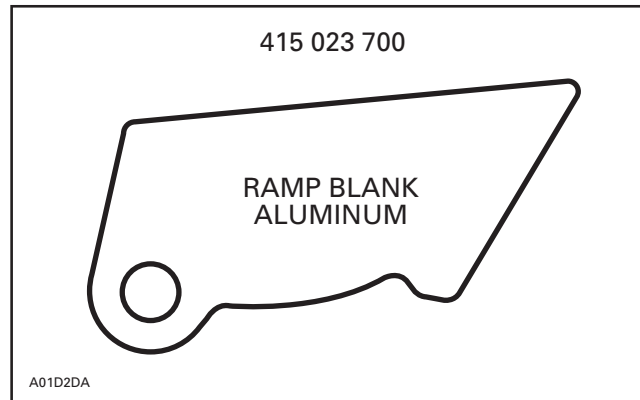
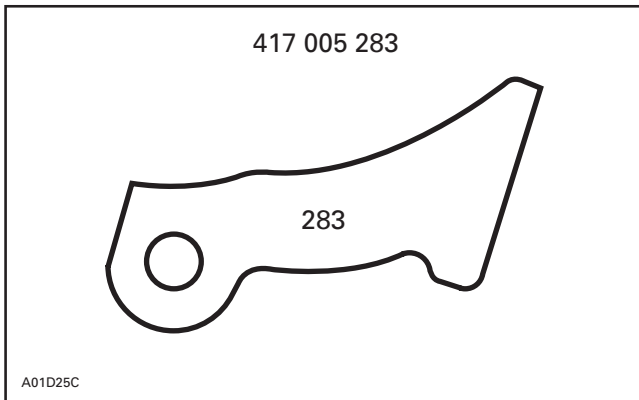
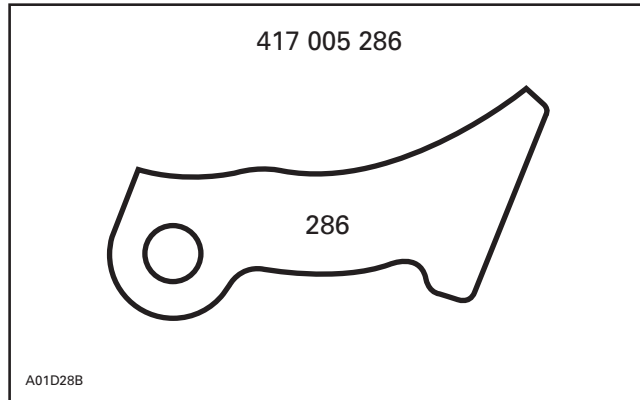
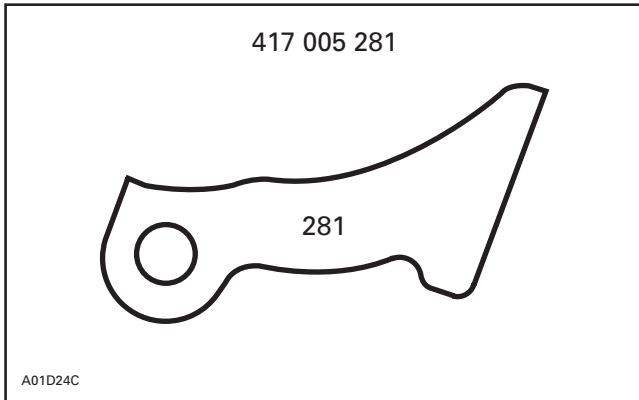

SECTION 05 - DRIVE SYSTEM

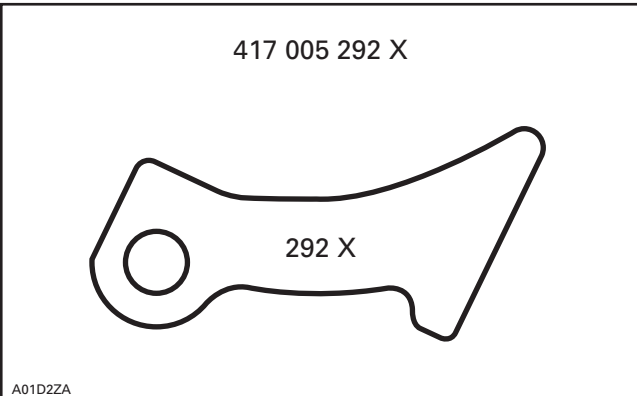
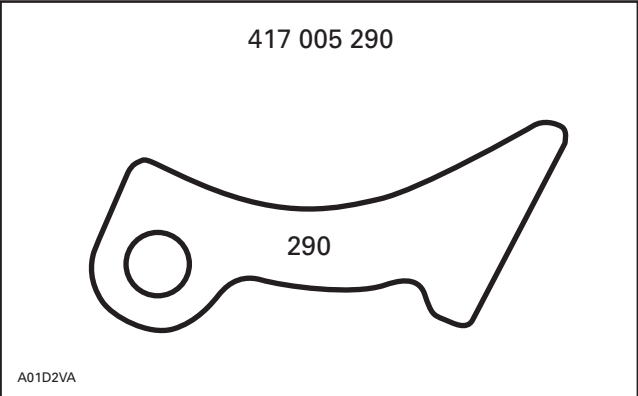
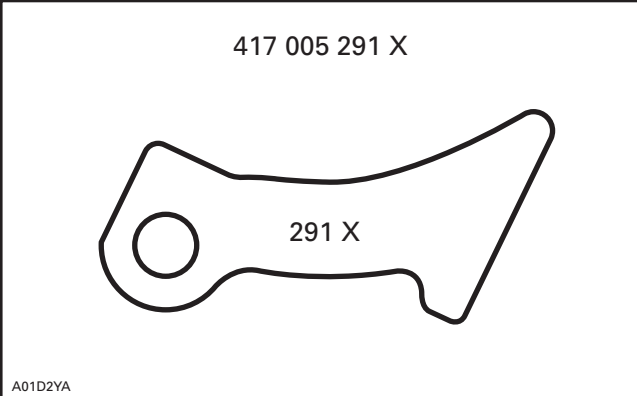
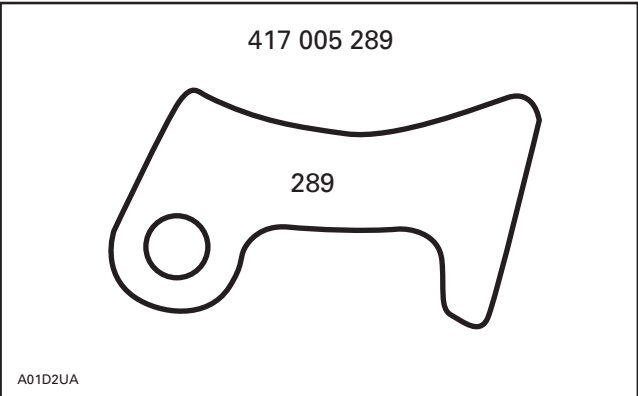
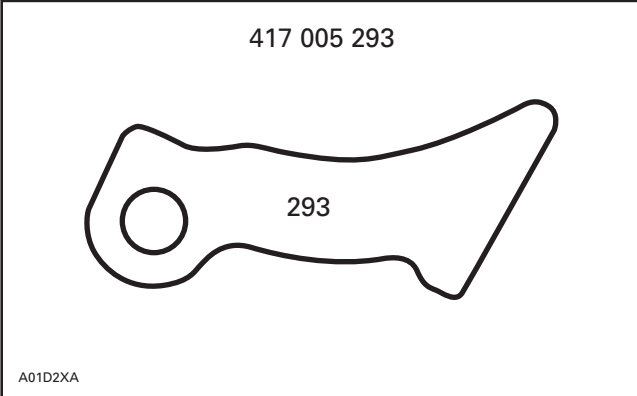
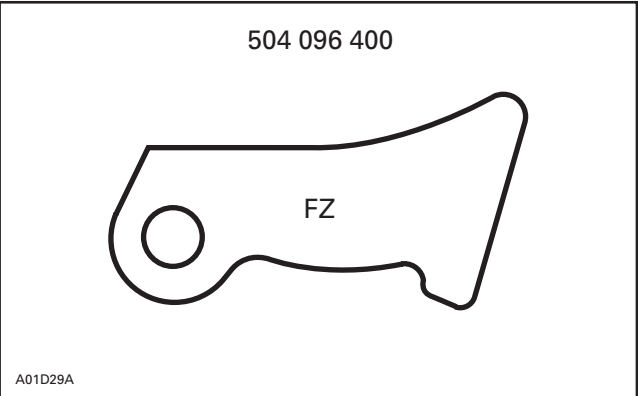
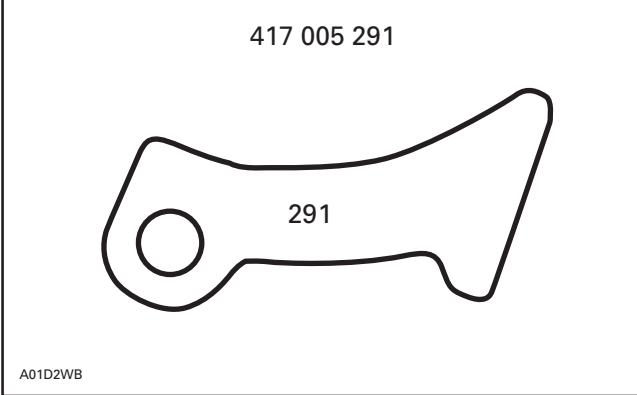
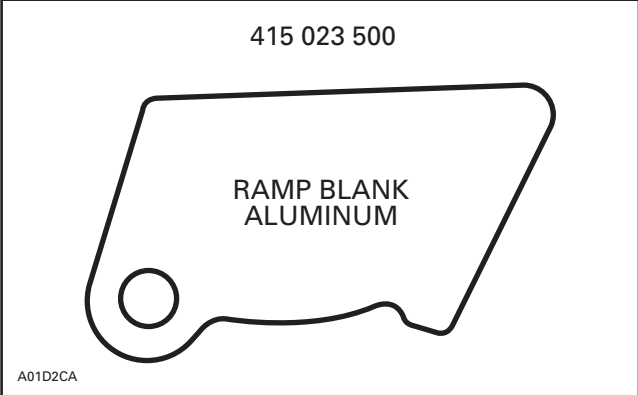

SECTION 05 - DRIVE SYSTEM

417 005 293 X

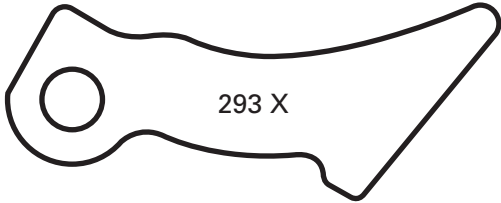

A01D30A

417 005 297 X

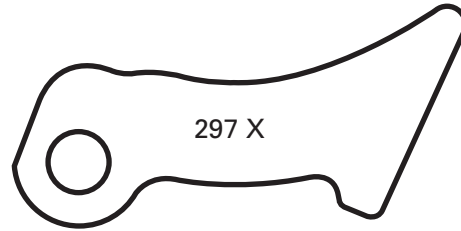

A01D34A

417 005 294 X

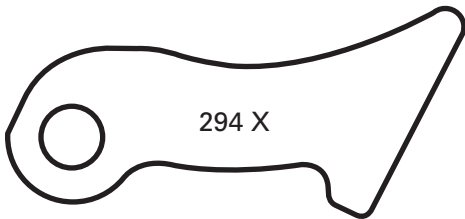

A01D31A

417 222 271

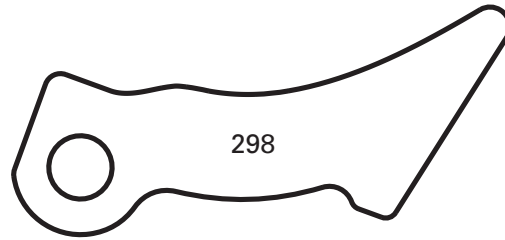

A01D37A

417 005 295 X

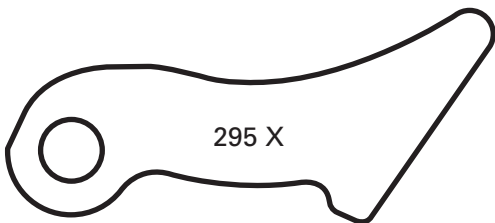

A01D32A

417 222 372

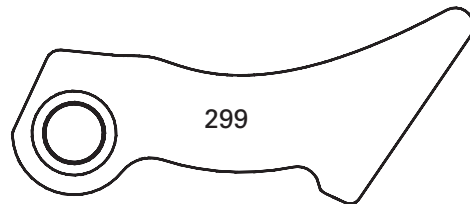

A01D38A

417 005 296 X

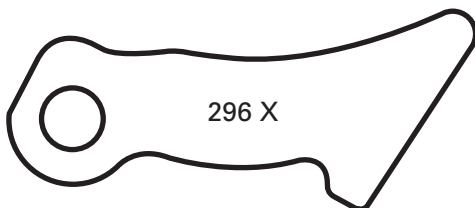

A01D33A

417 222 381



A01D3AA

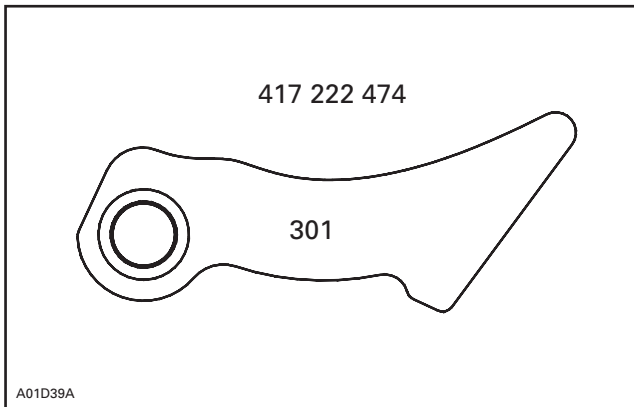

EFFECTS OF THE DRIVE PULLEY SPRING

The purpose of the clutch release spring is to return the sliding half of the engine pulley and the associated moving parts to the disengaged or neutral position at low engine RPM. The spring tension is calibrated to work with the pressure levers and ramp angles to allow clutch engagement at the desired RPM. As the engine speed increases, centrifugal forces increase and eventually overcome the tension of the release spring and allow the pulley halves to contact the drive belt. As engine speed decreases, centrifugal forces decrease and the clutch spring returns the sliding half toward the neutral position.

As the clutch shifts out to a higher ratio, the spring balances the shift forces being generated by the levers and ramps.

The spring tension will affect the entire shifting sequence of the engine pulley. The effect that it has will depend upon the construction of the spring. Three things must be known about the spring to be able to predict its effect in the clutch: 1. The spring free length; 2. The spring pressure when compressed to 74 mm (2.9 in); 3. The spring pressure when compressed to 41 mm (1.6 in). These three factors are listed on the accompanying sheet.

The spring free length will give you an idea of the condition of the spring. If the spring has lost more than 6.35 mm (1/4 in) of its listed free length, the spring is fatigued or has taken too great a set. The spring should be replaced. The free length of the spring is its overall length when resting freely on a table top.

In the TRA clutch, the installed length of the clutch release spring is 74 mm (2.9 in). This is the length of the spring when the pulley is in its neutral position. The pressure that the spring applies at this length is the factor that controls the engagement speed (all other things kept constant). When the engine pulley is in its highest ratio position, the spring will be compressed to 41 mm (1.6 in). The pressure the spring applies at this length will determine the RPM required to reach high gear; again, with all other tunable factors kept constant.

As you look through the spring chart, you will see that springs are available with equal pressures at 74 mm (2.9 in), but very different pressures at 41 mm (1.6 in). You will also note varying pressures at 74 mm (2.9 in) and equal pressures at 41 mm (1.6 in). Simply by working with the spring charts, one can easily see how the shift speed (the speed with which the change from one gear ratio to the next is made) and the engagement speed can be altered.

As the pressure of the spring when 74 mm (2.9 in) long is increased, the clutch engagement speed will increase. As the spring rate is increased, the engine will be required to turn more RPM to achieve a given gear ratio. Again, these facts hold true when all other tunable components are kept constant.

On chart 1, spring **A** has a pressure of 311 N (70 lb) at 74 mm (2.9 in) and a pressure of 1157 N (260 lb) when compressed to 41 mm (1.6 in). With no other changes made in the clutch, spring **B** was installed. The spring has a preload of 712 N (160 lb) at 74 mm (2.9 in) and a pressure of 1201 N (270 lb) at 41 mm (1.6 in). As the chart indicated, the engagement RPM increased 1000 RPM while the shift curve from 30 MPH up remained relatively unchanged.

Chart 2 illustrates the effect of keeping the spring preload pressure at 74 mm (2.9 in) constant and increasing the pressure at the 41 mm (1.6 in) length. In this example, spring **A** has a pressure of 311 N (70 lb) at 74 mm (2.9 in) and a pressure of 756 N (170 lb) at 41 mm (1.6 in). Spring **B** also has a pressure of 311 N (70 lb) at 74 mm (2.9 in) but increases to 1157 N (260 lb) at 41 mm (1.6 in). The projected effect of this spring change is shown on chart 2. Since the preload pressure at 74 mm (2.9 in) is equal for springs **A** and **B**, the engagement speed is not affected. At 95 MPH, however, there is a loss of RPM with spring **A** in place.

SECTION 05 - DRIVE SYSTEM

Drive Clutch Spring

Effect at Engagement

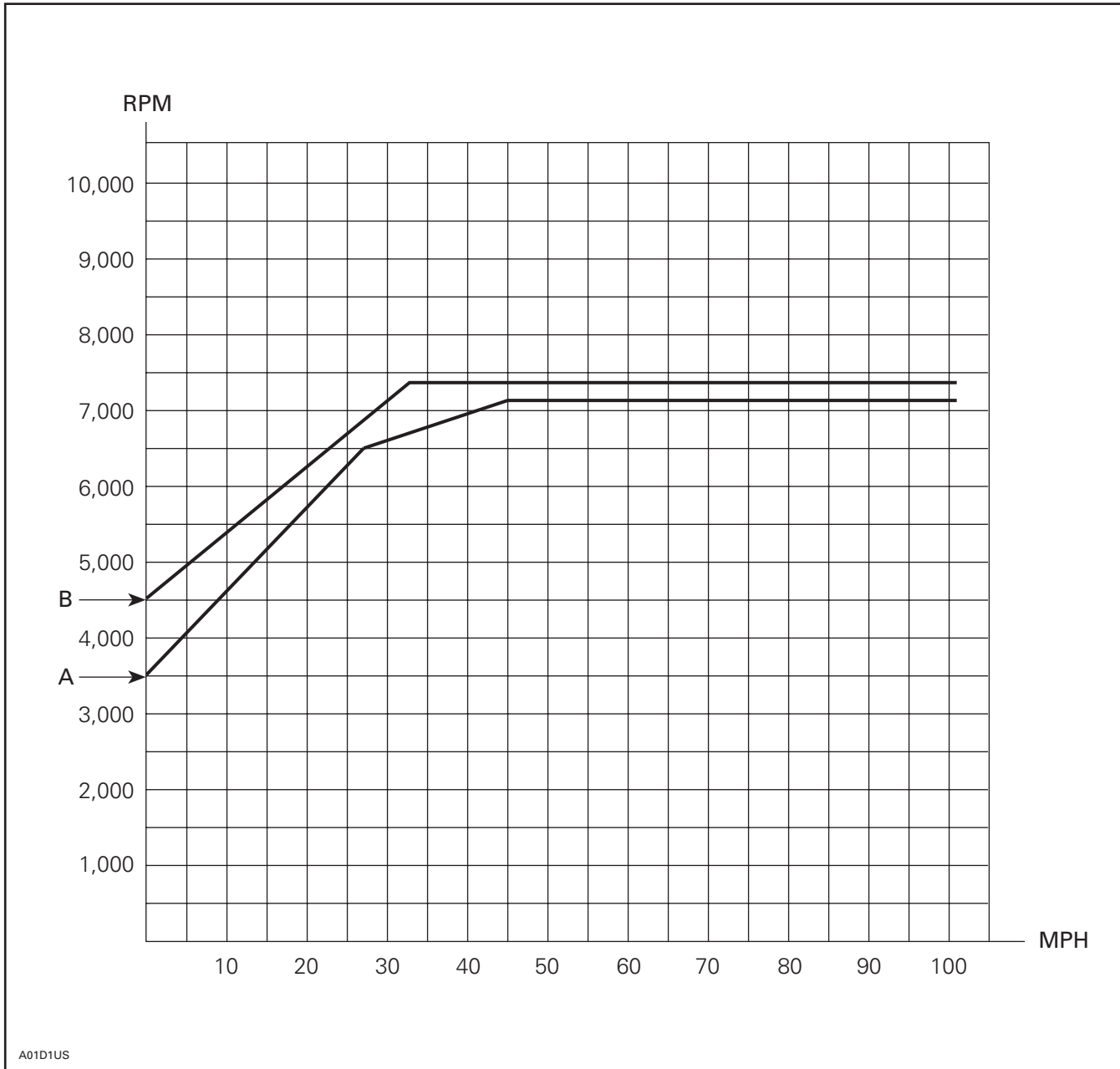

	LOAD AT 74 mm (2.9 in)	LOAD AT 41 mm (1.6 in)
A	311 N (70 lb)	1157 N (260 lb)
B	712 N (160 lb)	1201 N (270 lb)

**Drive Clutch Spring
Effect at Top Speed**

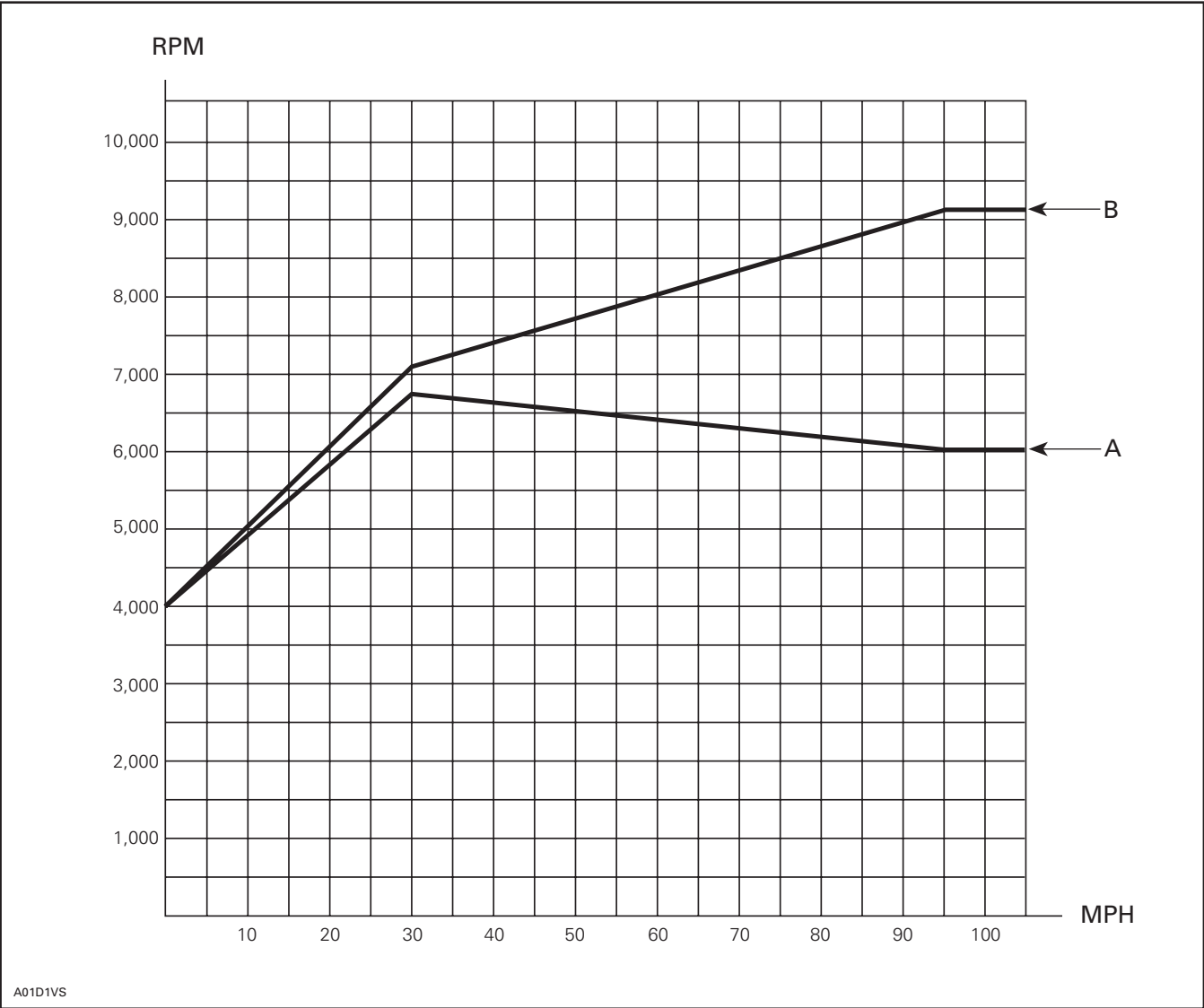

	LOAD AT 74 mm (2.9 in)	LOAD AT 41 mm (1.6 in)
A	311 N (70 lb)	756 N (170 lb)
B	311 N (70 lb)	1157 N (260 lb)

SECTION 05 - DRIVE SYSTEM

TRA SPRINGS CHART

FORCE @ POUNDS ± 5% 74 mm - 41 mm 2.9 in - 1.6 in	P/N BOMBARDIER	COLOR CODE	WIRE DIA.		FREE LENGTH	
			mm	in	mm	in
70 - 170	414 689 800	RED - RED	5.26 5.00	0.207 0.197	99	3.9
70 - 200	415 015 200	RED - ORANGE	5.26	0.207	94	3.7
70 - 230	414 817 500	RED - YELLOW	5.54	0.218	89	3.5
70 - 260	414 689 200	RED - GREEN	5.94	0.234	88	3.5
70 - 290	414 691 500	RED - BLUE	5.94	0.234	86	3.4
70 - 320	414 701 000	RED - PURPLE	6.35	0.250	85	3.3
100 - 170	414 993 000	YELLOW - RED	4.88	0.192	128	5.0
100 - 200	414 689 700	YELLOW - ORANGE	5.26	0.207	110	4.3
100 - 230	414 748 600	YELLOW - YELLOW	5.54 5.41	0.218 0.213	102	4.0
100 - 260	414 742 100	YELLOW - GREEN	5.72 5.94	0.225 0.234	96	3.8
100 - 290	414 818 000	YELLOW - BLUE	5.94	0.234	97	3.8
100 - 320	414 678 400	YELLOW - PURPLE	6.35 6.17	0.250 0.243	93	3.7
130 - 200	414 639 000	BLUE - ORANGE	4.88 5.00	0.192 0.197	145	5.7
130 - 230	414 689 500	BLUE - YELLOW	5.26	0.207	125	4.9
130 - 260	414 817 700	BLUE - GREEN	5.54	0.218	109	4.3
130 - 290	414 689 400	BLUE - BLUE	5.94	0.234	104	4.1
130 - 320	414 817 800	BLUE - PURPLE	6.17 5.94	0.243 0.234	98	3.9
130 - 350	414 916 300	BLUE - PINK	6.35 6.17	0.250 0.243	96	3.8
150 - 240	414 605 600	WHITE	5.26	0.207	135	5.3
160 - 230	415 015 300	PURPLE - YELLOW	4.88	0.192	158	6.2
160 - 260	415 015 400	PURPLE - GREEN	5.26	0.207	133	5.2
160 - 270	414 605 500	YELLOW	5.26 5.54	0.207 0.218	130	5.1
160 - 290	415 034 900	PURPLE - BLUE	5.54 5.72	0.218 0.225	120	4.7

SECTION 05 - DRIVE SYSTEM

FORCE @ POUNDS ± 5% 74 mm - 41 mm 2.9 in - 1.6 in	P/N BOMBARDIER	COLOR CODE	WIRE DIA.		FREE LENGTH	
			mm	in	mm	in
160 - 320	414 817 900	PURPLE - PURPLE	5.72 5.94	0.225 0.234	111	4.4
160 - 350	414 949 500	PURPLE - PINK	5.94 6.17	0.234 0.243	105	4.1
185 - 410	415 019 500	"ALL" BLACK	6.35	0.250	105	4.1
200 - 290	414 768 200	GREEN - BLUE	5.26	0.207	156	6.1
200 - 320	414 762 800	GREEN - PURPLE	5.54 5.72	0.218 0.225	135	5.3
200 - 350	414 756 900	GREEN - PINK	5.72	0.225	126	5.0
200 - 380	414 222 371	GREEN - WHITE	5.94	0.234		
230 - 350	415 074 800	PINK - PINK	5.54	0.218	143	5.6
230 - 380	414 991 400	PINK - WHITE (OLD) RED - WHITE	5.94 5.72	0.234 0.225	128 134	5.0 5.3
230 - 390	415 019 600	GREEN	5.94	0.234	126	5.0
230 - 410	415 019 700	RED	5.94	0.234	120	4.7
240 - 430	415 019 800	BLUE	5.94	0.234	120	4.7
250 - 380	417 222 004	WHITE - WHITE (OLD) GREEN - WHITE	5.72	0.225	140	5.5
250 - 460	415 019 900	PINK	6.17	0.243	116	4.6
260 - 420	417 222 164	WHITE - SILVER (OLD) ORANGE	5.94	0.234	135	5.3
280 - 420	415 020 100	GREEN - GREEN	5.72	0.225	146	5.7
280 - 460	415 020 200	RED - RED	6.17	0.243	132	5.2
280 - 510	415 020 300	BLUE - BLUE	6.35	0.250	121	4.8
310 - 460	415 020 400	PINK - PINK	5.94	0.234	148	5.8
310 - 510	415 020 500	ORANGE - ORANGE (OR) GOLD - GOLD	6.17	0.243	132	5.2

Part numbers with a 486 prefix must be ordered from the Valcourt Race Dept. All others must be ordered from your local Ski-Doo dealer.

CLUTCH SPRINGS	
TENSION	PART NUMBER
180 - 410	486 103 200

200 - 290	487 103 300
220 - 320	488 103 400
220 - 384	489 103 500
240 - 380	490 103 600

SECTION 05 - DRIVE SYSTEM

260 - 380	491 103 700
260 - 410	492 103 800
280 - 410	493 103 900

EFFECTS OF THE DRIVEN PULLEY SPRING

The driven pulley spring is needed to keep the plastic slider buttons in contact with the cam and to provide enough side force on the belt in the low gear position to allow initial acceleration while the torque rises to a point where the torque sensing cam begins to take over. At full load, the driven pulley spring has much less effect on the driven pulley shifting sequence than does the cam, especially at low shift ratios. At the part throttle loads at low ratios, the spring has the main effect on the shift characteristics of driven pulley.

Increases in the driven pulley spring preload will bring the engine speed up before the pulley starts shifting and will help backshift the clutch quicker. Decreasing the preload will allow a faster upshift but a slower backshift thus lowering the engine RPM.

NOTE: Control of the engine speed is done by calibrating the engine pulley not by adjusting the driven pulley spring preload. An attempt to lower the engine RPM by decreasing the spring preload in the driven pulley will result in belt slippage on acceleration. An attempt to increase engine RPM by increasing the preload will result in excessive drive belt wear and decreased efficiency in the transmission.

The driven pulley spring preload is listed in the basic specifications for all our machines. This preload tension will vary from 4 kg (9 lb) to 7.5 kg (17 lb) on models equipped with the TRA clutch.

The preload figure given in our specifications is quoted in kg (lb) of force for each machine, not in inch-pounds or foot-pounds of torque. A figure given in units of torque would require multiplying the radius of the pulley by the pull recorded on the scale. Our figures are quoted for each pulley size and it is only necessary to record the pull of the spring by attaching a scale to the rim of the pulley. The scale must be positioned at 90° to the radius of the pulley. Holding the fixed half of the pulley still, pull until the sliding half just begins to rotate. At this point, read the scale.

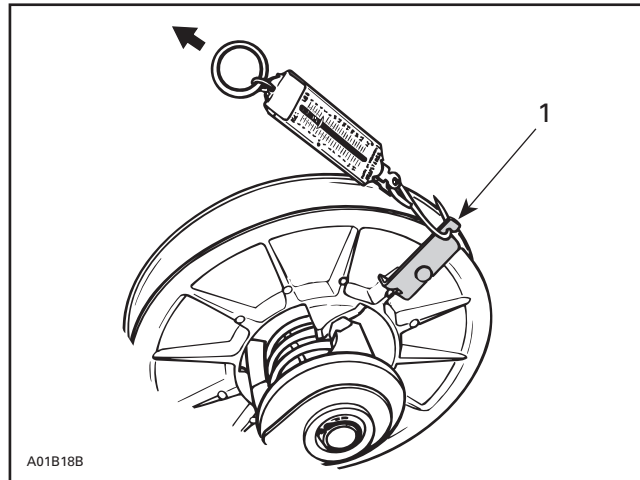

TYPICAL

1. Spring scale hook (P/N 529 030 900)

To change the spring tension, relocate the spring end in the sliding pulley half or reposition the spring end in the cam.

There are six holes available on a Formula cam. They are numbered 1-6. Most Formula driven pulleys have three adjustment holes in the sliding half. They are lettered A, B, C. When adjusting driven pulley tension, always refer to the tension in kg (lb) — not B-6 or A-5 hole positions for accuracy and repeatability. Moving the spring from one numbered hole to a hole adjacent will change the preload by 1.35 -1.8 kg (3-4 lb). Remember, use the number and letters as references — measure the tension for accuracy. By using various combinations, the preload is adjustable from 5 to 35 pounds (depending on spring type).

The charts below will give an approximate reference for each spring position. It will vary with different springs and cam angles.

DRIVEN CLUTCH PRELOAD

WHITE SPRING/LBS			
POSITION	A	B	C
1	26	29	24
2	21	23	20
3	16	19	15
4	11	14	10
5	7	10	6
6	3	5	1

BEIGE SPRING/LBS			
POSITION	A	B	C
1	14	16	12
2	9	11	7
3	4	6	2
4	28	30	26
5	23	25	21
6	18.5	20.5	16.5

Our procedure is as follows:

- Remove the drive belt and lock the parking brake.
- Using a reliable fish scale and our spring scale hook (P/N 529 030 900) pull perpendicular to the rim of the pulley until the moveable sheave begins to open. Record the reading on the fishscale.
- Next while the pulley is still being pulled open, relax the tension on the fish scale until the moveable pulley begins to close, record the reading.
- **Next add the two readings together and divide by two. This is the number we use as our reference.**
- Recording **only the pull** reading and this will definitely allow the driven pulley tension to be too low. This low tension will lead to a noticeable drop in peak RPM and a loss of top speed.

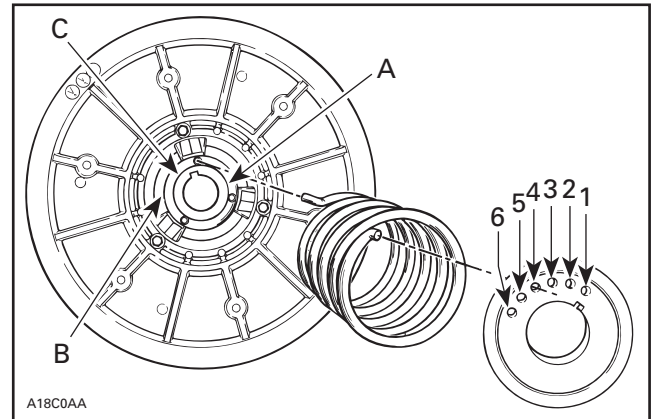

Letters and numbers shown in illustration are actual letters and numbers embossed on parts

NOTE: Always recheck torsional pre-load after adjusting.

By experimenting with them, you may find a more efficient combination of minimum side pressure yet adequate back shifting for your particular racing application.

COLOR	WIRE DIAMETER	PART NUMBER
BEIGE	.207 in	414 558 900
WHITE	.207 in	504 152 070
YL/BK	—	486 104 000

Part numbers with a 486 prefix must be ordered from the Valcourt Race Dept. All others must be ordered from your local Ski-Doo dealer.

EFFECTS OF THE DRIVEN PULLEY CAM

The purpose of the driven pulley cam is to sense the torque requirements of the drive axle and feed a portion of the engine torque, which has been applied to the driven pulley, back to the sliding half of the pulley. It is this side force that signals the downshift and provides side thrust to give traction to the drive belt.

The cam is acting like a screw pushing against the sliding half of the pulley. A large cam angle will act like a coarse thread while a small cam angle will act similar to a fine thread. The smaller the cam angle, the greater the side force on the sliding half of the pulley and the slower the upshift will be. This will result in higher engine RPM.

SECTION 05 - DRIVE SYSTEM

A larger cam angle will allow the pulley to upshift at a lower engine speed. Less side force will be exerted on the sliding half of the pulley and the pulley will upshift more rapidly.

On downshift, a smaller cam angle will backshift more easily and, again, tend to keep the engine RPM higher. A larger cam angle will be harder to downshift and will load the engine and reduce the RPM.

If all other variables in the pulleys are kept constant, a cam change with a smaller angle will result in a slower upshift and a faster downshift. Engine RPM will remain higher. A change to a cam with a larger angle will result in a faster upshift and the downshift will be slower. Engine RPM will be lower.

Remember the drive pulley signals or controls the upshift of the transmission while the driven pulley signals the downshift largely because of the effect of the cam.

The standard factory cam will probably work well for most **woods** type cross-countries, while a smaller angled cam may prove to be better for high speed lake cross-countries.

Top speed and low ET's are drag racers' and radar runners' most important concerns. Because backshifting is not at all important in these races, most racers experiment with larger cam angles for the fastest possible upshift.

Multi-angle cams are sometimes used by racers needing a good holeshot. They generally work best on vehicles where no track spin is encountered. As a vehicle idles on the starting line, the exhaust temperature cools thus slightly lowering the optimum HP RPM of the engine. Because of this, a steeper (larger) angle cam can be used to upshift more quickly, and lower the RPM to work with the cooler exhaust. As the exhaust heats up, the optimum HP RPM increases. A multi-angle cam reduces to a shallower (smaller) angle as the clutch shift out and the RPM is increased to match the **hot** HP curve of the engine. This phenomena is more pronounced on engines with narrower powerbands.

Oval and snowcross racers need the best of both worlds. A good holeshot is critical but backshifting must be quick in order to have good response out of the corners. They may have to change cam angles depending on what type of track layout is encountered.

Driven pulley cams are helices. A helix is measured in lead. Lead is the distance a point moves along the axis of rotation in one revolution of the helix. (Screw threads are a helix).

The helix angle is computed from the lead and the circumference of the helix.

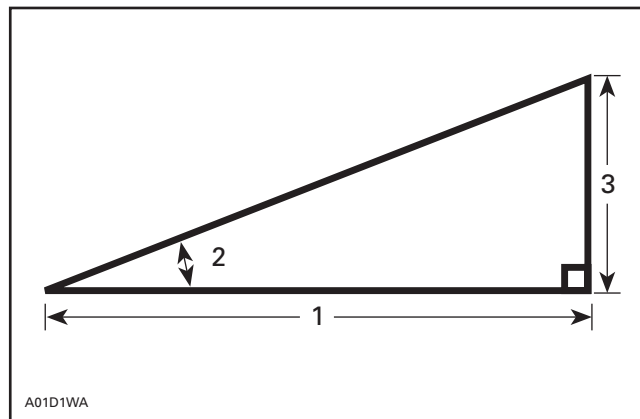



1. Circumference (C)
2. Helix angle A
3. Lead (L)

DRIVEN CLUTCH CAMS

							
FORMULA - STD		FORMULA RER & VSA			HPV 27 & VSA		
PART NUMBER	ANGLE	PART NUMBER	TYPE	ANGLE	PART NUMBER	TYPE	ANGLE
860 424 800	40	417 126 715	RER	44 Alu.	417 126 445	VSA	44 Anod.
860 424 900	42	417 126 683	RER	47 Alu.	417 126 577	VSA	47 Anod.
860 425 000	44	417 126 716	RER	50 Alu.	417 126 724	VSA	47-40 Anod.
860 425 100	47	417 126 685	RER	48-44 Alu.	417 126 385	VSA	47-44 Anod.
860 425 200	50	417 126 680	RER	50-47 Alu.	417 126 721	VSA	50-40 Anod.
860 425 300	53	417 126 747	RER	44 Anod.	417 126 580	VSA	50-47 Anod.
860 427 600	56-50	417 126 748	RER	47 Anod.			
860 427 500	56-47	417 126 749	RER	50 Anod.	417 126 740	27	53-50 Anod.
860 427 400	56-44	417 126 750	RER	48-44 Anod.	417 126 741	27	53-47 Anod.
860 427 300	53-50	417 126 751	RER	50-47 Anod.	417 126 722	27	50-40
860 427 200	53-47				417 126 725	27	47-40
860 427 100	53-44	417 126 718	VSA	44 Anod.	417 126 674	27	44-40
860 427 000	53-42	417 126 707	VSA	47 Anod.	417 126 742	27	40-44
860 426 900	53-40	417 126 719	VSA	48-44 Anod.	417 126 743	27	44-47
860 426 800	50-47	417 126 704	VSA	50 Anod.	417 126 744	27	47-50
860 426 700	50-44	417 126 720	VSA	50-47 Anod.			
860 426 600	50-42						
860 426 500	50-40						
860 426 400	50-37						
860 426 300	47-44						
860 426 200	47-42						
860 426 100	47-40						
860 426 000	47-37						

SECTION 05 - DRIVE SYSTEM

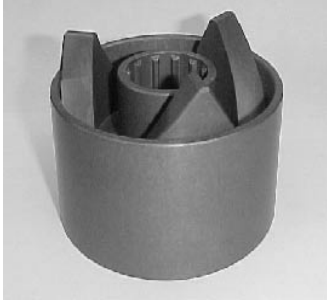
							
FORMULA - STD		FORMULA RER & VSA			HPV 27 & VSA		
PART NUMBER	ANGLE	PART NUMBER	TYPE	ANGLE	PART NUMBER	TYPE	ANGLE
860 425 900	44-40						
860 425 800	44-37						
860 425 600	42-37						
860 425 500	40-44						
860 425 400	40-37						
<p>All cams have been anodized coated. The standard Formula cam has been used for several years and is still in use today, primarily in the MX Zx 440 Formula Roller driven clutch. The standard Formula cam can be used in place of a Formula RER or VSA cam, providing the reverse function has been disabled.</p>		<p>The Formula RER and VSA cams are interchangeable. The difference between the two types is the number of holes drilled for spring tension and bearing surface. RER and VSA cams may be used in place of standard Formula cams also.</p>			<p>The HPV 27 and VSA cams are interchangeable. The difference between the two types is the number of holes drilled for spring tension adjustment. These cams are not interchangeable with Formula style cams.</p>		

Alu.: Aluminum

Anod.: Anodized

DRIVE BELTS

The drive belt is the critical link in transmitting power from one clutch to the other. The changes in belt technology and materials have allowed us to take for granted the kind of reliability and efficiency that not many years ago we all only dreamed about.

One of the more important changes in drive belts has been the introduction of Kevlar® Fiber B to replace fiberglass or polyester cord in the tensile layer of modern drive belts. This material is much stronger, more flexible, and allows a better adhesive bond with the various rubber compounds used to build a drive belt.

Another important change in drive belts is the increase in width. The extra width allows us to add more Kevlar cords in the tensile layer for strength with today's high output sleds.

Use only the specific Bombardier drive belt listed for your application. The drive belt is a calibrated part of the transmission system. Different belts with different compounds or angles will change how your transmission shifts.

Drive belts can vary ± 6 mm (1/4 in) length from belt to belt. Because of this manufacturing tolerance, we recommend measuring your drive belts and marking their length on the outer cover. Try to use only belts that are the same length while racing to keep your clutch set up as consistent as possible.

SECTION 05 - DRIVE SYSTEM

Always break in a new belt by running it easy for 10-15 miles. Vary the vehicle speed and throttle setting without going over 2/3 throttle. It is also a good idea to mark the direction of rotation on the belt. Once the belt has been used, always run it in the same direction.

Be careful not to bend sharply or coil up these new hard compound drive belts since they are much more prone to cracking in cold weather than earlier belts.

Proper deflection, setup, alignment, and break-in will help insure maximum performance and longevity from the drive belt.

PART NUMBER	WIDTH (new)	MINIMUM WIDTH (wear limit)
415 060 600	34.7 mm	32.30 mm
414 860 700	34.90 mm	32.50 mm
417 300 067	35.00 mm	33.00 mm
417 300 066	35.10 mm	33.00 mm
417 300 127	35.10 mm	32.10 mm
414 827 600	33.33 mm	30.00 mm

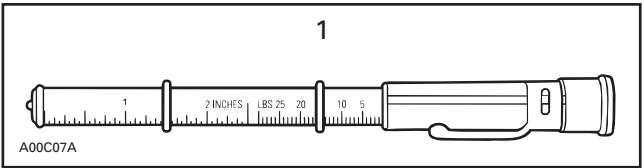

1. Use Ski-Doo tool (P/N 414 348 200)

Proper belt deflection and alignment are extremely important. Included is a page on proper alignment procedures and deflection measurement methods for your use.

Do not forget about the torque limiter rod on most models. This bolt is located between the jackshaft and the engine on the left side. It should be lightly snugged **after** the proper alignment and center to center distances have been set.

NOTE: Do not overtighten, it will misalign pulleys.

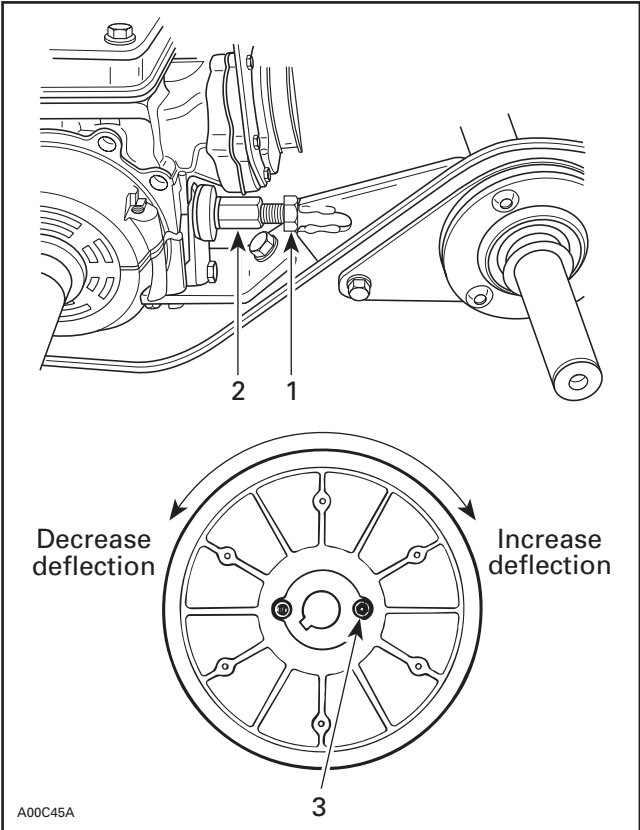

TYPICAL

- 1. Jam nut
- 2. Adjuster
- 3. Allen screw with jam nut

SECTION 05 - DRIVE SYSTEM

The driven pulley has three set screws on the fixed half that are used for setting belt deflection. These 3 mm Allen screws can be moved in or out to open or close the sheaves to lower or raise the drive belt in the driven pulley to achieve the correct deflection.

It is best to accurately align the pulleys and then shim the driven clutch tight. Some feel it is better to let it float and align itself. But this doesn't happen in a dynamic situation when there is load on the belt. If you have a lot of float in the driven and you back off the throttle and the pulley misaligns, when power is applied again, the pulley will stay misaligned because of the force on the countershaft. Shimming the driven pulley tightly to the jackshaft bearing also helps to positively position the jackshaft and its left side bearing.

CHAINCASE GEARING

Contrary to popular belief, small gear changes do not directly affect top speed as long as the clutches are functioning properly. Gearing one or two teeth taller on the top will not generally make the vehicle any faster on top end unless the clutches are fully shifted out and the engine is starting to overrev.

With the TRA clutch, we have about 20 percent more shift ratio available compared to other designs. Because of this, we have been able to lower the gearing in our chaincase considerably. Yet, we still have the same overall top gear ratio because of the 0.8:1 top ratio of the TRA clutch.

This gives us better belt life by allowing our clutches to **slip** for a shorter period of time at engagement. It also provides more torque to the drive axle for acceleration.

Most snowmobiles are geared on the **high** side from the factory. They are usually geared for 8 -16 km/h (5-10 MPH) more than they would reach in average conditions. Because of this, the belt does not seem to go all the way to the top of the drive clutch. This is a normal situation. Snowmobiles run under widely varying conditions. If all snowmobiles were geared to attain a full shift under average conditions and then the vehicle were run on a perfectly smooth frozen surface, it would easily shift out to its geared top speed. Since the drag is so low under these conditions, the engine would begin to over-rev, eventually lose power, possibly damage the engine, and you will not achieve top speed.

There are other factors involved here also. As clutches shift through their range, the efficiency with which they transmit power decreases as the clutch ratio exceeds about 1.5:1. Efficiency also drops as belt speed (RPM) increases. For optimum chaincase performance ensure that you use the synthetic chaincase oil.

Because newer clutch designs shift beyond a 1:1 ratio, belt speed increases dramatically and the diameter that the belt follows around the driven pulley decreases considerably. This wastes energy and efficiency as the belt is being bent around a smaller diameter and centrifugal force is trying to pull the belt into a circular path instead of following the pulleys.

This is why for years manufacturers kept their clutch ratios around 1:1 to keep belt speeds down.

Now with the advent of larger displacement, high torque, lower RPM engines, we can use overdrive transmissions and still keep our belt speeds within reason.

As we mentioned, as belt speeds go up, efficiency drops. This is one reason many radar runners gear extremely high sometimes even approaching 1:1 in the chaincase. They have found through diligent testing that they can achieve a higher top speed without shifting their clutches all the way out because of a decrease in belt speed which means an increase in transmission efficiency. That is their bottom line.

For oval racing, the small benefit you may achieve in top end speed would probably be lost by the loss of acceleration on the start and out of the corners on a tight oval circuit.

SECTION 05 - DRIVE SYSTEM

This holds true for cross-country and snow crossers also. Top speed is not as important as quick acceleration out of the corners and ditches.

You can easily check your gearing selection by marking your drive clutch with a black marker with straight lines from bottom to top on the belt surfaces of the clutch. Go out and ride your sled under your normal conditions and stop to see how far the belt has rubbed the marker off the clutch surfaces. If it has shifted the belt all the way to the top, you may be able to pull one or two more teeth on the top sprocket. Experiment!

If it is down about 1/2 in or more from the top, you could consider trying a one tooth smaller top gear depending upon your type of racing.

The best combination of gearing for speed and acceleration you can achieve is far more important than shifting the belt **all the way to the top** of the clutches.

The following formula can be used to calculate the theoretical top speed of your Ski-Doo. The formula assumes the transmission is shifted out to its top gear ratio. Make sure you use the correct track pitch and transmission ratio for your machine.

TRA clutch top ratio = .83

Pitch of internal drive track = 2.52 in

Number of teeth on internal drive sprocket = 9

NOTE: Some Summit and long track models use 8 tooth drive sprockets.

$$\text{top speed in MPH} = \frac{\text{engine RPM}}{\text{clutch ratio}} \times \frac{\text{teeth, top sprocket}}{\text{teeth, bottom sprocket}} \times \frac{(\text{pitch of track} \times \text{No. of teeth on drive sprocket})}{12} \times \frac{60}{5280}$$

A little known fact that can seriously impair a racer's performance is the misconception that the factory stated peak horsepower RPM or the peak power point you find on a dyno is the correct figure to clutch your race sled to.

Generally, this is not the case. The figures that are printed by the factory are determined on a dynamometer in clinical test conditions.

CHAINS BOMBARDIER P/N			
LINKS	11 WIDE	13 WIDE	15 WIDE
68	412 106 600	—	—
70	412 105 900	412 106 800	486 093 100
72	412 105 500	412 106 700	486 074 300
74	412 105 800	412 106 900	504 151 910
76	—	412 107 600	—

SECTION 05 - DRIVE SYSTEM

GEARS						
	11 WIDE		13 WIDE		15 WIDE	
TEETH	STEEL	POWDER	STEEL	POWDER	STEEL	ALUMINUM
TOP						
17	504 071 800	—	486 070 400	—	—	—
18	—	504 070 100	486 070 500	—	—	—
19	—	414 680 500	486 070 600	—	486 092 600	—
20	504 074 800	—	486 070 700	—	486 092 700	—
21	504 084 000	—	504 139 300	—	486 092 800	—
22	504 074 700	504 056 000	504 083 500	504 091 100	486 074 600	—
23	504 078 400	504 087 800	504 085 400	504 091 000	486 093 000	—
24	504 078 600	504 056 100	503 139 700	504 090 900	—	—
25	504 084 100	504 085 200	—	504 084 300	—	—
26	—	504 055 900	—	504 085 300	—	—
27	—	—	—	—	—	—

	11 WIDE		13 WIDE		15 WIDE	
BOTTOM						
38	504 056 400	—	—	—	—	—
39	—	—	—	—	—	—
40	414 339 600	504 056 200	—	504 089 000	—	—
41	—	—	—	—	—	—
42	—	—	—	—	—	—
43	—	504 748 500	—	504 148 500	—	489 104 600
44	—	504 057 300	—	504 085 500	486 074 400	—
44R	504 076 500	504 088 200	—	504 084 400	—	—

Part numbers with a 486 prefix must be ordered from the Valcourt Race Dept. All others must be ordered from your local Ski-Doo dealer.

TRANSMISSION CALIBRATION PROCEDURE

1. A new vehicle should be broken-in before fine tuning the transmission. 200 — 300 miles will allow things like bearings and the track to loosen-up. This will allow the sled to roll much freer which may slightly change the clutch calibration.
2. Set up the chassis configuration (lowering, weight transfer, traction).
3. Adjust the carburetor calibration to match the condition of the day.
4. Pick the chain case ratio.
5. Define the driven pulley calibration. Stock is a good starting point. Drag racers may consider trying a larger cam angle. Use multi-angle cams only for fine tuning after working with the drive clutch.
6. Choose the drive belt (compound, length, width).
7. Define the TRA calibration.
 - Start with the stock ramp in position #3.
 - For most forms of racing, a higher engagement RPM can be utilized. The better the traction, the higher the engagement that can be used. Most stock grass drag rules limit engagement to 5500 RPM. That's 5500 RPM on the technical inspector's tachometer and it may not agree with your dash tachometer. If in doubt, get the tech. man to verify your engagement. The easiest way to raise engagement is to use a spring with a higher start load and a similar finish load. Remember, the stiffer spring at start will also affect the shift curve at 0 to 1/2 ratio.
 - If the stiffer spring slowed down the shift at low ratios, try more roller pin weight. The pin weight will not change engagement much but will shift faster. Utilize the threaded roller pins to achieve pin weights in between the hollow steel and solid steel pin.
 - Fine tune the shift curve by trying different adjuster positions. Use the lowest adjuster number that still allows you to maintain RPM.

- Pin weight and ramp angle are interrelated, but can be varied to achieve certain results. A 16.5 gram pin and the adjuster set in #5 may produce the same full throttle RPM as a 14.5 gram pin with the adjuster set in #3, but the lighter pin will be revving higher at part throttle setting at low ratios. This may work better for snowcross or woods racing whereas the heavier pin may be better in a drag race. Some ramp profiles will achieve better top speed with the adjusters set in lower numbers (1-4). If you are in position 5 or 6, try a slightly lighter pin weight (1.5 to 2 grams) and lower the adjuster position.

NOTE: Never use adjuster position #6 with the FZ ramp. The tip of the ramp may touch the lever arm.

- If your shift curve is perfect but the engagement is too low, a flat or notch can be ground in the ramp right where the roller sits at neutral position. This is a touchy procedure and should only be attempted as a last resort. Be prepared to scrap some ramps during the learning procedure.
8. The best way to test clutching is with a set of timing lights or side by side comparison with a similar vehicle. Leave one machine as a base line reference while tuning the test vehicle. Don't change things on both vehicles at the same time or you won't know if you are gaining or losing. Also, only change one parameter at time on your test vehicle so you know exactly what results from the change.
 9. For drag racers, try running the engine down to several hundred RPM below the stated power peak. When the exhaust is cold, the peak power RPM drops. How much lower depends on the engine type, exhaust type, jetting and underhood temperature. Summer and fall grass draggers should especially try lower RPM.
 10. This is where the winners become winners. Test, test, test and then go test some more.
 11. **KEEP DETAILED NOTES OF ALL YOUR TESTINGS!!!** No matter how good you think your memory is, after you test your hundredth combination, things can get overwhelming.

SECTION 05 - DRIVE SYSTEM

TRANSMISSION TUNING TEST SHEET

DATE: _____ VEHICLE: _____ SHEET NO.: _____
 TEST SITE: _____ TEMPERATURE: _____ SURFACE COND.: _____

	TEST 1	TEST 2	TEST 3	TEST 4	TEST 5
Cam angle					
Spring color code					
Spring preload, lb					
Spring position ex.: (A-4)					
Chaincase gearing					
Lever arm and pin type					
Weight each assembly					
Ramp identification					
No. of set screws added (if used)					
Spring color code/tension					
TRA adjuster position					
Belt part number					
Width					
Length					
Engagement RPM					
Shift RPM					
Top speed					
Time for run/measured distance					
Variation min./max.					
Special notes					

SECTION 05 - DRIVE SYSTEM

RACERS LOG

VEHICLE:		DATE:		SHEET NUMBER:	
LOCATION:		SURFACE CONDITIONS:			
TEMPERATURE:		BAROMETRIC PRESSURE:		HUMIDITY:	
CARBURETOR SIZE:		FUEL:		C.R.A.D.:	
	PTO	MAG	Carburetion notes:		
Main jet					
Needle jet					
Jet needle					
E-clip position					
Slide cut-away					
Pilot jet					
Drive pulley			Clutching notes:		
Lever arm/pin type					
Pin weight					
Ramp identification					
TRA adjuster position					
Spring identification					
Spring pressure @ engagement					
Spring pressure @ full shift					
Engagement RPM					
Shift RPM					
Drive belt identification					
Driven pulley					
Cam identification					
Spring identification					
Spring preload and location					
Chaincase gearing					
	LH	RH	Chassis notes:		
Inches of carbide/ski					
Camber					
Front spring identification					
Ride height					
Center spring identification					
Limiters adjustment					
Rear spring identification					
Ride height					
Stud quantity and type					

TABLE OF CONTENTS

2003 OPEN MOD SNOCROSS ENGINE SPECIFICATIONS & PARTS 793 (ROTAX) 2 CYLINDERS ..	06-2
DRIVE CLUTCH PARTS LIST.....	06-3

SECTION 06 - 2003 800 MOD ENGINE KIT

2003 OPEN MOD SNOXCROSS ENGINE SPECIFICATIONS & PARTS 793 (ROTAX) 2 CYLINDERS

BORE	82 mm
STROKE	75.7 mm
CC	799.2 cc
SQUISH	1.4 mm (.055 in)
VOLUME COMBUSTION CHAMBER (FLAT PLATE)	28.6 cc
CYLINDER HEAD INSERT DOME	P/N 420 613 810
CYLINDER HEAD DOME COVER	P/N 420 613 800
IGNITION	290 watts
ELECTRONIC BOX	P/N M512 059 304
STATOR	P/N 410 922 931
IGNITION COIL	P/N 512 059 564
RAVE SPRING 0.8 X 52.0	P/N 420 239 941 (blue)
NO THERMOSTAT	Use gasket P/N 420 850 338 (but put restriction in bypass hose with 1/8 dia. hole in the restriction.
CYLINDER	P/N M420 613 852
RAVE VALVE	P/N 420 854 465
VALVE COVER	P/N 420 911 558
PISTON PIN BEARING	Cageless P/N 420 832 425 With cage P/N 420 832 442 (optional)
O-RING FOR CUP	P/N 420 950 890
SQUARE O-RING	P/N 420 931 590
O-RING	P/N 420 931 410
PISTON	P/N 420 889 480
PISTON RING (CKS)	P/N 420 815 360
PISTON PIN	P/N 420 916 370
CIRCLIP	P/N 420 845 106

BASE GASKET AVAILABLE	P/N 420 931 836 P/N 420 931 837 P/N 420 931 838 P/N 420 931 839 P/N 420 931 964 (already installed on the engine)
.4 mm	
.6 mm	
.5 mm	
.8 mm	
.7 mm	
CRANKSHAFT	P/N 420 888 407
CRANKCASE	P/N 420 888 279
SPARK PLUG	BR9ES (gap .016 in)
CARBURETOR	TMS 38 Taper Bored P/N 486 130 002
THROTTLE CABLE	P/N 486 130 007
THROTTLE HANDLE	P/N 572 101 900
AIR FILTER - KICKASS	P/N 486 100 400
FUEL PUMP	P/N 403 901 200
REED VALVE RIMOLDI ASS'Y	P/N 420 924 790
FLYWHEEL	P/N 420 866 990
DRIVE CLUTCH	Clutch ass'y - forged Ramp 293 pos. 4 Arm, std. aluminum Pin, metric . 42 mm (16.2 gr) Spring 250-380 Set screw metric (3.0 gr) Set screw (option) (2.3 gr) Set screw (option) (3.8 gr) Set screw (option) (.73 gr)
	P/N 486 098 400 P/N 417 005 293X P/N 417 222 383 P/N 486 130 005 P/N 415 019 400 P/N 206 262 099 already in pin P/N 206 261 699 P/N 206 262 599 P/N 206 260 699
DRIVEN CLUTCH	Cam 50-47° Spring - beige
	P/N 486 076 200 B-6 21 lb
BELT (DAYCO)	P/N 414 860 700
GEARING 21-43	P/N 504 152 044 & P/N 504 148 500
CHAIN 74 LINKS	P/N 504 151 910
BELT GUARD (meets ISR rules)	P/N M417 300 220
BELT GUARD SIDE PANEL (REV chassis)	P/N 486 130 010

SECTION 06 - 2003 800 MOD ENGINE KIT

DRIVE CLUTCH PARTS LIST

PART NUMBER	DESCRIPTION	QTY
486 098 400	Drive Pulley Ass'y (Forged)	1
417 222 383	Lever Ass'y	3
417 004 305	Bushing	6
417 003 900	Roller Ass'y	3
417 004 302	Stopper Washer	6
486 130 005	Pin	3
206 262 099	Set Screw 3 gr	@
732 958 001	Cotter Pin	3
417 004 800	Screw Ass'y	3
232 561 414	Elastic Stop Nut M6	3
417 222 044	Spring Seat	1
415 019 400	Spring	1
414 222 304	Spring Cover Ass'y	1
417 004 501	Bushing	1
250 000 038	Socket Head Screw M6 x 40	3

PART NUMBER	DESCRIPTION	QTY
420 245 370	Washer	3
417 005 293 X	Ramp	3
732 804 009	Rolled Pin M8 x 24	3
210 361 890	Hex. Screw M6 x 18	6
417 005 500	Calibration Screw	3
417 005 600	Washer	3
233 061 414	Hex. Flanged Nut M6	3
417 005 700	Spring	3
732 401 030	O-Ring	6
417 222 362	Slider Shoe	6
413 703 100	Loctite 609, 10 c.c.	@
206 260 699	Optional Metric Set Screw .7 gr	
206 261 699	Optional Metric Set Screw 2.3 gr	
206 262 599	Optional Metric Set Screw 3.8 gr	

SECTION 06 - 2003 800 MOD ENGINE KIT

	Engine Type:	793
	Stroke:	75.7
	C.R. Length:	132
DEGREE	PISTON POS. (mm)	PISTON POS. (inch)
0	0	0.000
1	0.01	0.000
2	0.03	0.001
3	0.07	0.003
4	0.12	0.005
5	0.19	0.007
6	0.27	0.010
7	0.36	0.014
8	0.47	0.019
9	0.60	0.024
10	0.74	0.029
11	0.89	0.035
12	1.06	0.042
13	1.24	0.049
14	1.44	0.057
15	1.65	0.065
16	1.88	0.074
17	2.12	0.083
18	2.37	0.093
19	2.64	0.104
20	2.92	0.115
21	3.21	0.126
22	3.52	0.139
23	3.84	0.151
24	4.17	0.164
25	4.52	0.178

	Engine Type:	793
	Stroke:	75.7
	C.R. Length:	132
DEGREE	PISTON POS. (mm)	PISTON POS. (inch)
26	4.88	0.192
27	5.25	0.207
28	5.63	0.222
29	6.03	0.237
30	6.43	0.253
31	6.85	0.270
32	7.28	0.287
33	7.73	0.304
34	8.18	0.322
35	8.64	0.340
36	9.12	0.359
37	9.60	0.378
38	10.10	0.398
39	10.60	0.417
40	11.12	0.438
41	11.64	0.458
42	12.17	0.479
43	12.72	0.501
44	13.27	0.522
45	13.83	0.544
46	14.40	0.567
47	14.97	0.589
48	15.56	0.612
49	16.15	0.636
50	16.74	0.659

Recommended fuel:

Use Racing fuel **R + M** 114 octane (VP C14 or
2

Phillips B33 with pre-mix oil 25 to 1 (good quality of synthetic oil)

SECTION 06 - 2003 800 MOD ENGINE KIT

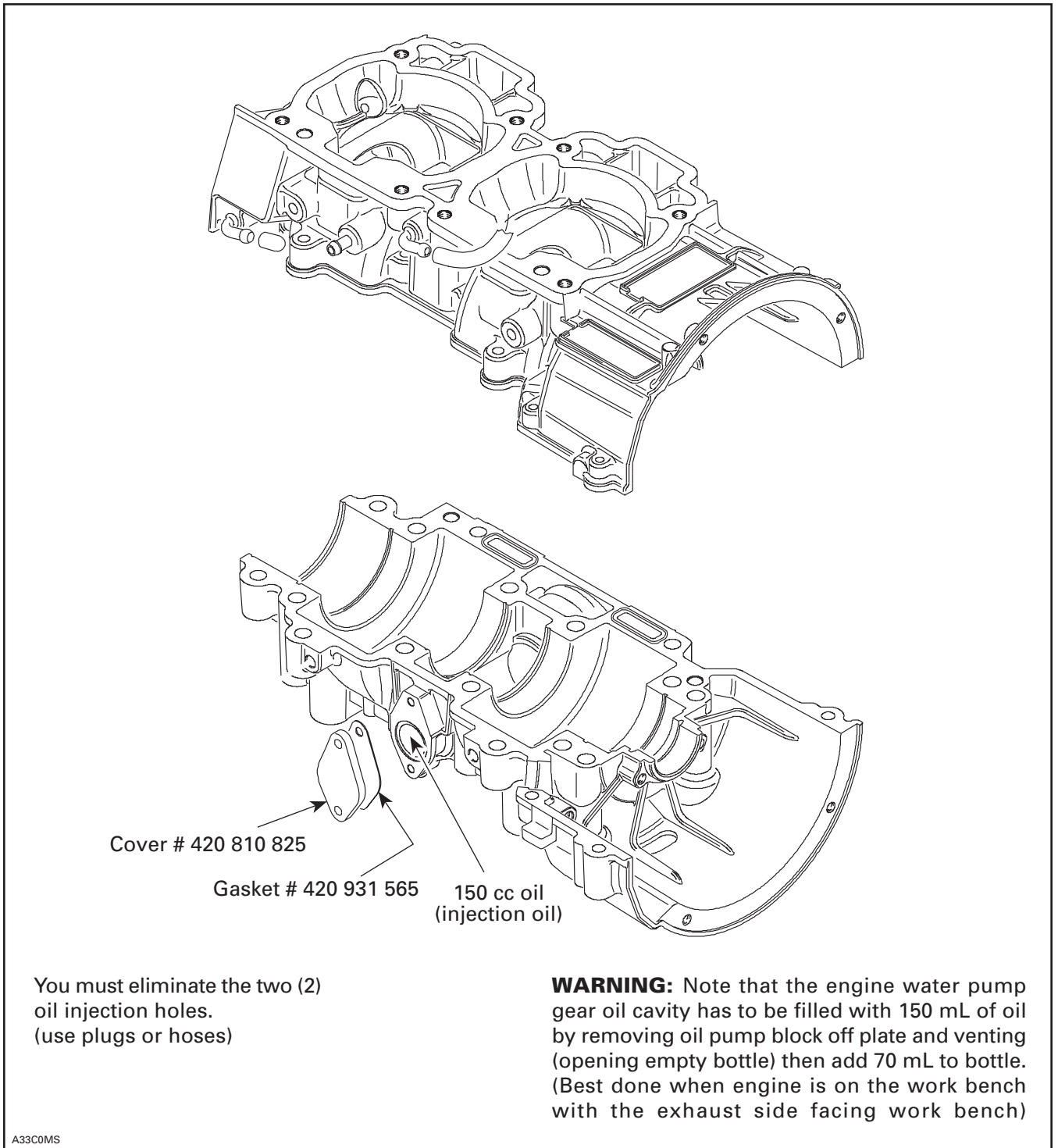

SECTION 06 - 2003 800 MOD ENGINE KIT

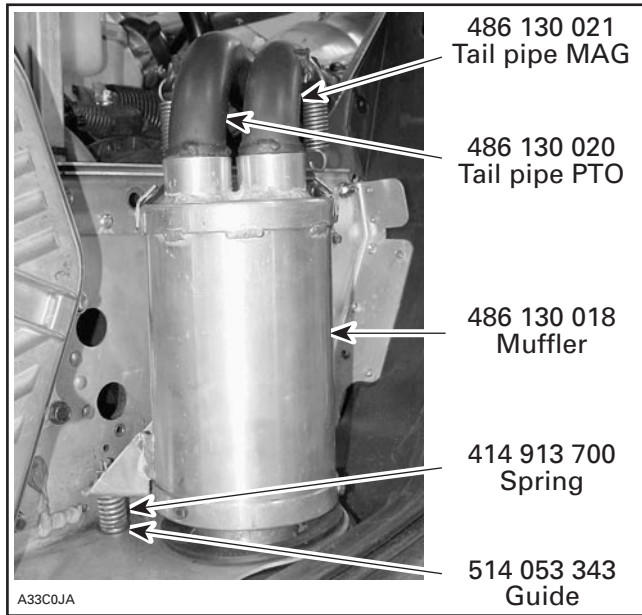
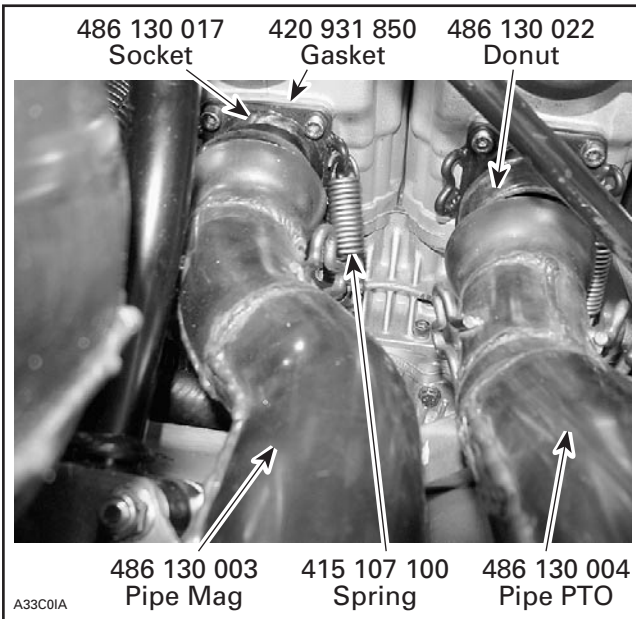
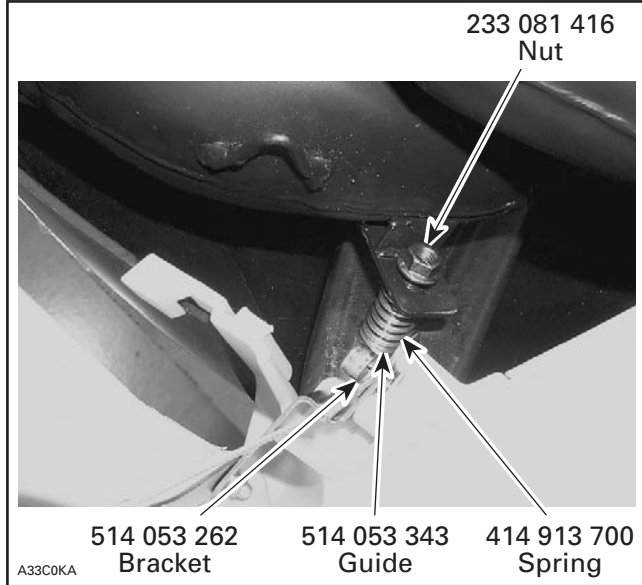
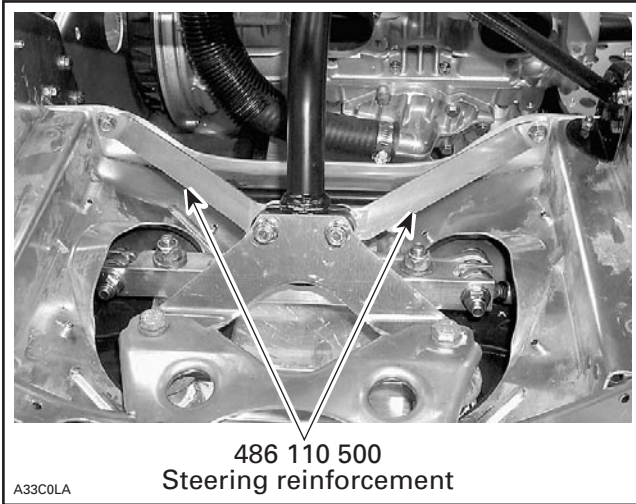

TABLE OF CONTENTS

WARRANTY BULLETIN.....	07-2
PROBLEM.....	07-2
SOLUTION	07-2
PARTS REQUIRED	07-2
PROCEDURE	07-3
WARRANTY	07-5
2002 MX Zx 440 SHOCK CALIBRATION	07-6
SERVICE PROCEDURES	07-9
CENTER SHOCK – 2002 MX ZX 440 LC – P/N 503 189 779.....	07-9
REAR SHOCK — 2002 MX Zx 440 LC — P/N 503 189 780	07-11
2002 SKI-DOO MX ZX RACING TIP SHEET NO. 1.....	07-13
2002 SKI-DOO MX ZX RACING TIP SHEET NO. 2.....	07-15

SECTION 07 - 2002 MX Zx 440 INFORMATION

Please route to :

	Init.
<input type="checkbox"/> Service	<input type="checkbox"/>
<input type="checkbox"/> Sales	<input type="checkbox"/>
<input type="checkbox"/> Parts	<input type="checkbox"/>

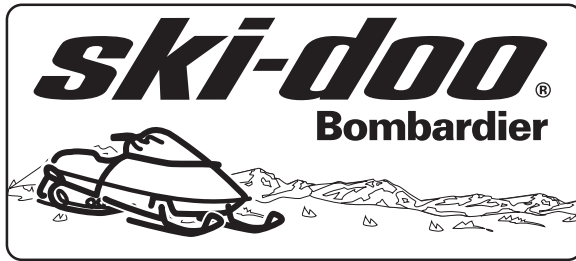

NOTE: Repair only if described symptoms exist or are noticed.

Campaign no.
2002-0007

No. **2002-10**

Date: January 11, 2002

**SUBJECT: MX Z[®]x 440 LC
Rear Shock Calibration**

YEAR	MODEL	MODEL NUMBER	SERIAL NUMBER
2002	MX Zx 440 LC	1948/2120/2129/2219	All

PROBLEM

Under very aggressive riding and/or racing application, the factory rear shock absorber calibration could be too stiff on compression damping.

SOLUTION

Re calibrate rear shock absorber.

CAUTION: Failure to perform this re calibration can lead, under very aggressive riding and/or racing application, to suspension damage.

Work could be performed by either

- A)** Dealer/Distributor,
- B)** Authorized Service Center.

A) Work Performed by Dealer/ Distributor

PARTS REQUIRED

DESCRIPTION	ITEM	PART NUMBER	QTY
Deflection Disc (0.9 x 0.015)	1	503 190 078	3
Deflection Disc (1.3 x 0.015)	2	503 190 098	7
Deflection Disc (0.7 x 0.008)	3	503 190 063	1
Deflection Disc (1.1 x 0.010)	4	503 190 086	1
Deflection Disc (0.7 x 0.010)	5	503 190 064	1
Shock Absorber Oil	6	503 190 103	1

Dealer/distributor needs to order parts through regular channel.

PROCEDURE

Disassembly

NOTE: Labor involved to remove and re install the shock absorber is not covered by Bombardier warranty.

⚠ WARNING

Before servicing a gas shock it is important that all the gas pressure be discharged from the unit. Refer to the instructions listed below for the proper procedure of discharging the gas pressure from a shock. Protective eye wear should be worn to avoid risk of injury while servicing RydeFX gas charged mono-tube shocks.

1. Remove the shock from the vehicle.
2. Wash the shock body with Bombardier Pulley Flange Cleaner (P/N 413 711 809); then dry with compressed air to remove sand and dirt.

⚠ WARNING

When using compressed air to dry components, protective eye wear should be worn to avoid risk of injury.

3. Remove sleeve and/or bushings from lower shock mount eyelet. Secure the shock in a horizontal plane by its lower mount in a vise. The use of soft jaws is recommend to prevent damage or marks to the shock.

CAUTION: It is important that the gas shock be retained in the vise by the lower mount. Any other method of securing the shock body during these procedures may deform the shock body cylinder.

4. Remove the small button head screw from the pressure valve assembly found on the bottom of the reservoir.
5. Using a slotted screwdriver, discharge all gas pressure from the shock by loosening the pressure valve assembly two (2) full turns counter-clockwise.



DISCHARGING GAS PRESSURE

⚠ WARNING

Nitrogen gas is under extreme pressure. Use caution when releasing nitrogen gas from shock. Protective eye wear should be worn to avoid risk of injury.

⚠ WARNING

Allow all the gas pressure to escape before proceeding with the removal of the pressure valve assembly. Pressurized gas could eject the valve assembly from the cylinder, resulting in bodily injury.

6. Using a 19 mm (3/4 in) wrench loosen and remove reservoir end cap.
7. Reposition shock absorber to a vertical upright position in vise by its lower mount.
8. Remove the reservoir bleed screw located opposite to the reservoir end cap. Account for O-ring.
9. Using a 32 mm (1-1/4 in) open face wrench, fully loosen and remove sealing cap and remove rod assembly placing it on a clean shop towel.
10. Pour the oil out of the shock reservoir and main cylinder body into waste container. Discard old oil into an approved storage container and dispose as per local environmental regulations. Never reuse damper oil during shock rebuilding.
11. Remove the internal floating piston from the reservoir by pushing the IFP with a push rod out of the reservoir. Account for wear band and O-ring.
12. Clean the inside of the shock body using clean parts-cleaning solvent and blow dry using compressed air.
13. Place the shock piston rod upper mount in bench vise, begin piston and valve removal using a 14 mm (35/64 in) open face wrench.

Arrange parts removed in the sequence of disassembly.

SECTION 07 - 2002 MX Zx 440 INFORMATION

14. Items to inspect:

- Piston rod/rod spacer for straightness, nicks or burrs.
- Sealing cap assembly/seals and scraper; clean, inspect, or replace.
- Inside of shock body for scratches, burrs or excessive wear.
- Teflon piston and I.F.P wear band for cuts, chipped or nicked edges, or excessive wear.
- O-rings for nicks, cuts, or cracks.
- Valve discs for kinks or waves.

Should any of these items be in question, replacement is recommended.

15. Discard the lower non-machined support shim.

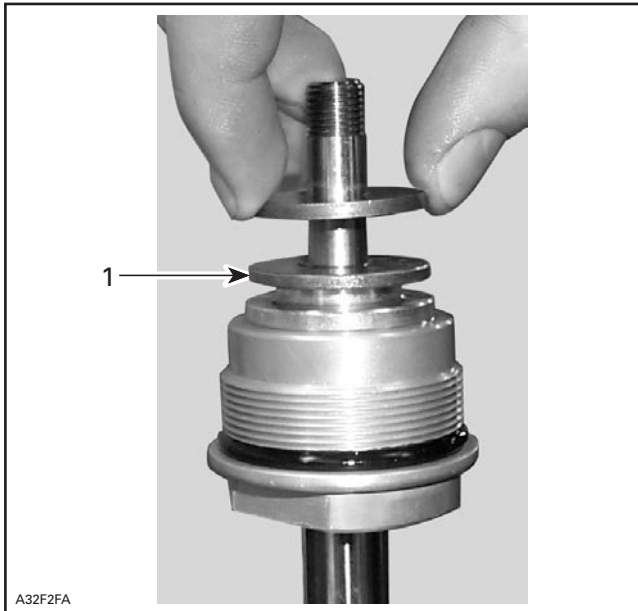

1. Remove this non-machined support shim.

Assembly

1. Place the piston rod upper mount into the vise. Reassemble damper rod assembly, with the new calibration, in the reverse order of disassembly.

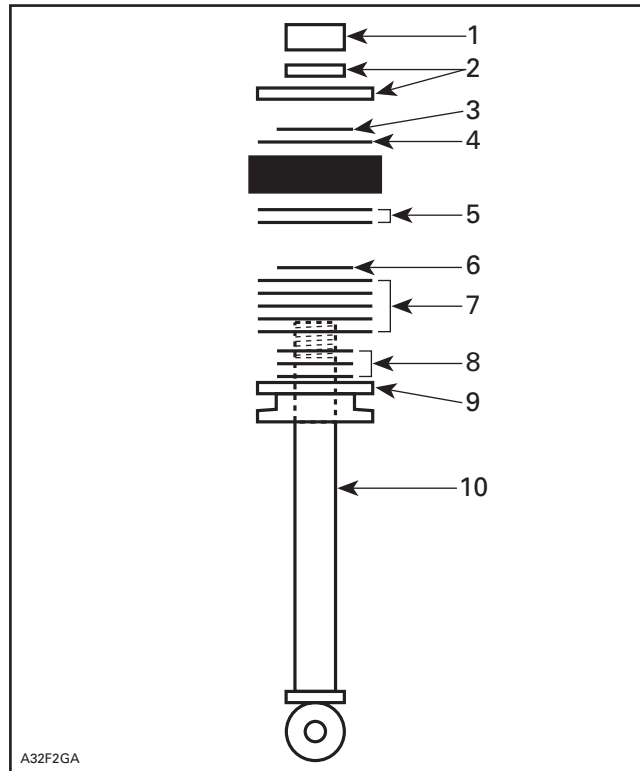

1. Nut
2. Washers
3. (1) 0.7 x 0.010 (P/N 503 190 064) item 5
4. (1) 1.1 x 0.010 (P/N 503 190 086) item 4
5. (2) 1.3 x 0.015 (P/N 503 190 098) item 2
6. (1) 0.7 x 0.008 (P/N 503 190 063) item 3
7. (5) 1.3 x 0.015 (P/N 503 190 098) item 2
8. (3) 0.9 x 0.015 (P/N 503 190 078) item 1
9. Machined Washer
10. Piston Rod

Special attention should be paid to the positioning of the rebound and compression disc (shim) stacks, ensuring that they are in the good order. Tighten the lock nut to 20-27 N•m (15-20 lbf•ft) of torque.

CAUTION: DO NOT OVER-TORQUE. If excessive torque is applied, damage to the piston and valves will occur.

2. Secure the shock in a horizontal plane by its lower mount in a vise. The use of soft jaws is recommended to prevent damage or marks to the shock.

CAUTION: It is important that the gas shock be retained in the vise by the lower mount. Any other method of securing the shock body during these procedures may deform the shock body cylinder.

3. Apply a thin film of oil onto the floating wear band and O-ring, and slowly install the floating piston into the bottom of the reservoir body.

SECTION 07 - 2002 MX Zx 440 INFORMATION

- Using the push rod, push the internal floating piston down into the reservoir to a depth of 94 mm (3-45/64 in) from the bottom of reservoir body.

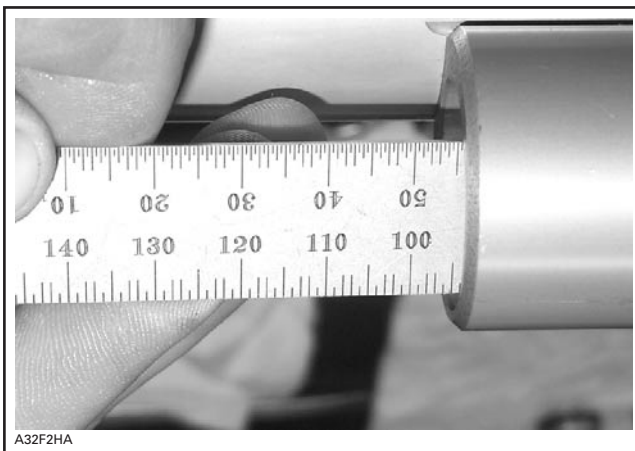

- Using a 19 mm (3/4 in) wrench re-install and tighten reservoir end cap into reservoir body. Securely tighten pressure valve assembly into reservoir end cap.
- Reposition shock absorber to a vertical upright position in vise by its lower mount.
- Fill the shock body with 240 mL of shock oil. The shock oil will flow through the passage port and simultaneously fill the reservoir to its top. **Use only RydeFX "SLIDE" branded shock fluid, P/N 503 190 103 (mandatory).**
- Re-install and securely tighten bleed screw into reservoir body.
- With the sealing cap assembly pushed down against the piston, carefully insert the piston rod assembly into the cylinder, slightly oscillating the piston rod to allow piston to enter shock body bore.
- Slowly push the piston rod assembly into shock body until the sealing cap assembly bottoms on the cylinder counter bore. Slight up and down movement may be required to allow all air to pass through piston assembly.

NOTE: During installation, some shock oil will overflow. Wrap a shop cloth around shock body to catch possible oil overflow. Fast installation of the piston rod assembly may force air into the shock and get trapped beneath the piston. This must not occur if the damper is expected to perform as designed.

- Using a 32 mm (1-1/4 in) open face wrench tighten sealing cap securely into the shock cylinder.
- Pressurize the shock reservoir, through the pressure valve, with nitrogen gas to 350 psi pressure.

NOTE: After being compressed, the piston rod should fully extend from the shock once the shock has been pressurized.

- Re-install the small button head screw in the pressure valve assembly and tighten securely.

After recharging is complete the rebuilt shock should be bench-tested. Stroke the shock to ensure full travel and smooth compression and rebound action. If the shaft moves in or out erratically this could indicate too much air is trapped inside. If the shaft will not move or has partial travel then it may be hydraulically locked. In either event the shock must be rebuilt again. Pay particular attention to the placement of the IFP, quantity of oil and shim stack/piston assembly.

- Re-install any sleeves and/or bushings in the lower shock mount.
- Reinstall shock absorber on vehicle **making sure reservoir is underneath.**

WARRANTY

Submit a warranty claim using the following information:

Campaign ① Number	2002-0007
Claim Type	07
Flat Rate	1.0 hour
Expiration Date	February 15, 2002

- ① This type of campaign **QUALITY** is excluded when calculating the warranty completion rate.

For claiming procedure, refer to the Dealer/Distributor *Warranty Guide*.

B) Work Done by Authorized Service Center

Should the dealer/distributor not be at ease with performing the re calibration, customer must be directed to the nearest of the authorized Service Centers listed below where he sends the shock absorber.

IMPORTANT: Customer must get an authorization, by phone, from the service center representative prior to requesting shock absorber re calibration, **by giving his name, phone number and the serial number of the involved sled.**

SECTION 07 - 2002 MX Zx 440 INFORMATION

Recalibration will be performed at **no charge to the customer.**

Customer is however responsible for the shipping and handling charges.

Authorized Service Centers

in the U.S.A.:

Carver Performance
Route 5, Box 21A
Thief River Falls
Mn 56701
Phone: 1-888-349-7469

in Canada:

Pro-Tech Suspension
2575 Remembrance Blvd.
Lachine, Qc
H8S 1X4
Phone: (514) 828-5058
Fax: (514) 828-5059

IMPORTANT: Dealer/distributor do not need to complete a warranty claim in this case, all duplicate claims will be debited to dealer/distributor.

2002 MX Zx 440 SHOCK CALIBRATION

	Front	Center	Rear
COMPRESSION	30 x .152 x 6	1.250 x .015	1 Backup Washer
	18 x .152 x 1	1.100 x .015	3 x 0.9 x 0.015
	30 x .203 x 4	.800 x .004	5 x 1.3 x 0.015
	24 x .114 x 1	1.300 x .015	1 x 0.7 x 0.008
	20 x .114 x 1	1.300 x .015	2 x 1.3 x 0.015
	16 x .114 x 1	.063 Piston Orifice	.076 Piston Orifice
REBOUND	26 x .152 x 6	1.100 x .008	1 x 1.100 x .010
	15 x .203 x 1	.700 x .010	1 x .700 x .010
	Piston 1 slit		
	IFP 43.5mm	IFP 48.3mm	IFP 94mm
BASE VALVE	4 slit washer		
	18 x .152 x 3		
	11 x .305 x 1		

Revised as per 2002 -10 Bulletin

SECTION 07 - 2002 MX Zx 440 INFORMATION

Shock Parts

2002 MX Zx 440			
BOMBARDIER P/N	DESCRIPTION	BOMBARDIER P/N	DESCRIPTION
REAR SHOCK (503 189 780) PARTS		CALIBRATION PARTS	
503 190 036	hose clamp	503 190 051	reservoir circlip
503 190 037	reservoir	503 190 052	monotube screw
503 190 038	rod assembly with upper mount	503 190 053	O-ring for monotube screw
503 190 039	cylinder head assembly 9/16	503 190 054	monotube screw
503 190 040	floating piston assembly	503 190 055	monotube screw
503 190 041	valve end cap sub-assembly	503 190 056	pressure valve assembly
503 190 042	rod spacer	503 190 057	pressure valve assembly
CENTER SHOCK (503 189 779) PARTS		503 190 058	thin collar stover nut
503 190 104	rod assembly with upper mount assembly and bumper and ice-scraper	503 190 059	monotube washer
503 190 043	cylinder head assembly	503 190 060	monotube washer
503 190 044	SS braided hose	503 190 061	.700 x .004 deflection disc
503 190 045	male elbow	503 190 062	.700 x .006 deflection disc
503 190 046	45 straight thread elbow	503 190 063	.700 x .008 deflection disc
503 189 998	spring retainer nut	503 190 064	.700 x .010 deflection disc
503 190 047	floating piston sub assembly	503 190 065	.700 x .012 deflection disc
503 190 048	reservoir end cap assembly	503 190 066	.700 x .015 deflection disc
503 190 049	reservoir top cap assembly	503 190 067	.800 x .004 deflection disc
503 190 050	reservoir cylinder	503 190 068	.800 x .006 deflection disc
		503 190 069	.800 x .008 deflection disc
		503 190 070	.800 x .010 deflection disc
		503 190 071	.800 x .012 deflection disc
		503 190 072	.800 x .015 deflection disc
		503 190 073	.900 x .004 deflection disc
		503 190 074	.900 x .006 deflection disc
		503 190 075	.900 x .008 deflection disc
		503 190 076	.900 x .010 deflection disc
		503 190 077	.900 x .012 deflection disc

SECTION 07 - 2002 MX Zx 440 INFORMATION

2002 MX Zx 440

BOMBARDIER P/N	DESCRIPTION
CALIBRATION PARTS	
503 190 078	.900 x .015 deflection disc
503 190 079	1.00 x .006 deflection disc
503 190 080	1.00 x .008 deflection disc
503 190 081	1.00 x .010 deflection disc
503 190 082	1.00 x .012 deflection disc
503 190 083	1.00 x .015 deflection disc
503 190 084	1.10 x .006 deflection disc
503 190 085	1.10 x .008 deflection disc
503 190 086	1.10 x .010 deflection disc
503 190 087	1.10 x .012 deflection disc
503 190 088	1.10 x .015 deflection disc
503 190 089	1.25 x .006 deflection disc

BOMBARDIER P/N	DESCRIPTION
503 190 090	1.25 x .008 deflection disc
503 190 091	1.25 x .010 deflection disc
503 190 092	1.25 x .012 deflection disc
503 190 093	1.25 x .015 deflection disc
503 190 094	1.30 x .006 deflection disc
503 190 095	1.30 x .008 deflection disc
503 190 096	1.30 x .010 deflection disc
503 190 097	1.30 x .012 deflection disc
503 190 098	1.30 x .015 deflection disc
503 190 099	monotube piston (blank)
503 190 100	monotube piston (.063)
503 190 101	monotube piston (.075)
503 190 102	gas fill tool kit
503 190 103	shock oil (blue)

	MX Z STD/ADRENALINE		MX Zx PACK		SUMMIT X	
Front	rebound 4 x 26 x .152 1 x 12 x .114 2 x 26 x .152 1 x 12 x .203 Piston = 2 slits IFP = 186 mm	compression 4 x 30 x .152 1 x 15 x .114 3 x 30 x .152 3 x 15 x .203	rebound 4 x 26 x .152 1 x 12 x .114 2 x 26 x .152 1 x 12 x .203 Piston = 2 slits IFP = 44.5 mm	compression 4 x 30 x .152 1 x 15 x .114 3 x 30 x .152 3 x 15 x .203	rebound 2 x 26 x .152 1 x 12 x .114 2 x 26 x .152 1 x 12 x .203 Piston = 2 slits IFP = 176 mm	compression 1 x 30 x .254 1 x 12 x .114 2 x 30 x .152 3 x 15 x .203
	Shock part # 505 070 733		Shock part # 503 070 876 Shock part # 503 070 878		Shock part # 503 070 753	
Center	rebound 4 x 26 x .203 1 x 12 x .254 Piston = 2 slits IFP = 132 mm	compression 4 x 30 x .203 1 x 15 x .114 2 x 30 x .203 3 x 15 x .203	rebound 4 x 26 x .203 1 x 12 x .254 Piston = 2 slits IFP = 128 mm	compression 4 x 30 x .203 1 x 15 x .114 2 x 30 x .203 3 x 15 x .203	rebound 4 x 26 x .203 1 x 12 x .254 Piston = 6 slits IFP = 134 mm	compression 6 x 30 x .152 1 x 12 x .114 6 x 30 x .152 3 x 12 x .203
	Shock part # 503 819 877		Shock part # 503 189 768		Shock part # 503 819 891	
Rear	rebound 10 x 26 x .203 1 x 12 x .203 Piston = 2 slits IFP = 189 mm	compression 5 x 30 x .203 1 x 12 x .114 4 x 30 x .203 3 x 12 x .203	rebound 7 x 36 x .203 1 x 20 x .305 Piston = 1.7 orifice IFP = 188 mm	compression 6 x 40 x .125 1 x 24 x .114 3 x 40 x .152 4 x 24 x .203	rebound 11 x 26 x .203 2 x 12 x .203 Piston = 4 slits IFP = 187 mm	compression 2 x 30 x .152 1 x 12 x .114 4 x 30 x .152 2 x 12 x .203
	Shock part # 503 819 879		Shock part # 503 189 801		Shock part # 503 819 895	

IFP: Internal Floating Piston

SERVICE PROCEDURES

CENTER SHOCK – 2002 MX Zx 440 LC – P/N 503 189 779

Disassembly

⚠ WARNING

Before servicing a gas shock it is important that all the gas pressure be discharged from the unit. Refer to the instructions listed below for the proper procedure of discharging the gas pressure from a shock. Protective eye-wear should be worn to avoid risk of injury while servicing any gas charged mono-tube shocks.

1. Remove the shock from the vehicle.
2. Remove spring and retainers.

NOTE: Before unscrewing pre-load springs, measure the compressed length of the installed spring and mark position for reinstallation.

CAUTION: When removing the spring from a shock that utilizes a fixed lower retainer; the use of a proper spring compressor should be used to avoid risk of bodily injury.

3. Wash the shock body in parts cleaner; then dry with compressed air to remove sand and dirt.

⚠ WARNING

When using compressed air to dry components, protective eyewear **MUST** be worn to avoid risk of injury.

4. Using a pair of cylinder blocks, secure the reservoir in a vise with the pressure valve end cap facing upwards.
5. Remove the small button head screw from the pressure valve assembly found on the bottom of the reservoir
6. Using a 9/16" wrench, discharge all gas pressure from the shock by loosening the pressure valve assembly three (3) full turns counter-clockwise.

⚠ WARNING

Nitrogen gas is under extreme pressure. Use caution when releasing nitrogen gas from shock. Protective eyewear should be worn to avoid risk of injury.

CAUTION: Allow all the gas pressure to escape before proceeding with the removal of the pressure valve assembly. Pressurized gas could eject the valve assembly from the cylinder - resulting in bodily injury.

7. Once the shock is completely discharged of gas pressure, remove the pressure valve assembly from the reservoir cylinder.
8. With your two thumbs, depress the reservoir end cap 12.7 mm (1/2 in), remove retainer cir-clip. Use care not to scratch the inside of the reservoir.
9. Reinstall pressure valve assembly partway into the end cap. Using pliers, grasp the end cap by the pressure valve assembly and extract the end cap slowly from the reservoir by pulling straight out.
10. Remove IFP bleed screw from Internal Floating Piston.
11. Remove Internal Floating Piston from the reservoir by grasping the inside edge of the IFP with pliers and pulling straight out. Account for wear band and O-ring.
12. Remove bearing sleeve and/or bushings from lower shock mount eyelet. Secure the lower mount of the shock in a vise. The use of soft jaws is recommend to prevent damage or marks to the shock.

CAUTION: It is important that the gas shock be retained in the vise by the lower mount. Any other method of securing the shock body during these procedures may deform the shock body cylinder.

13. Using a 1-1/4" open face wrench, fully loosen cylinder head and remove rod assembly, placing it on a clean shop towel.
14. Pour the oil out of the shock reservoir and main cylinder body into waste container. Discard old oil into an approved storage container and dispose appropriately. Never reuse damper oil during shock rebuild.
15. Clean the inside of the shock body using clean parts-cleaning solvent and blow dry using compressed air.

SECTION 07 - 2002 MX Zx 440 INFORMATION

16. Place the shock piston rod upper mount in bench vise, begin piston and valve removal. Arrange parts removed in the sequence of disassembly.
17. Items to inspect:
 - a. Piston rod for straightness, nicks or burrs.
 - b. Cylinder Head Assembly/DU Bearing/Seals and Scraper - clean, inspect, or replace.
 - c. Inside of shock body for scratches, burrs or excessive wear.
 - d. Teflon piston and I.F.P wear band for cuts, chipped or nicked edges, or excessive wear.
 - e. O-rings for nicks, cuts, or cracks.
 - f. Valve discs for kinks or waves.
 - g. Compression bumpers for chipping, cracking or being missing.
 - h. Braided hose and fittings for kinks, tears, worn or loose threads.

Should any of these items be in question replacement is recommended.

Assembly

1. Place the piston rod upper mount into the vise. Reassemble damper rod assembly in the reverse order of disassembly. Special attention should be paid the order of the Rebound and Compression disc (shim) stacks, ensuring that they are in the same order prior to disassembly. Tighten the lock nut to 21-27 N•m (15-20 lbf•ft) of torque.

CAUTION: DO NOT OVER-TORQUE. If excessive torque is applied, damage to the piston and valves will occur.

2. Using a pair of cylinder blocks, secure the reservoir in a vise with the pressure valve end cap facing upwards.
3. Apply a thin film of oil onto the floating piston wear band and O-ring and slowly install the floating piston into the top of the reservoir body.
4. Using the push rod, push the Internal Floating Piston down into the reservoir to a depth of 48 mm (1.9 in) from the top of reservoir body.
5. Secure the lower mount of the shock in a vise. The use of soft jaws is recommend to prevent damage or marks to the shock

CAUTION: It is important that the gas shock be retained in the vise by the lower mount. Any other method of securing the shock body during these procedures may deform the shock body cylinder.

6. Fill the shock body with 150 mL (5 oz U.S.) of shock oil. The oil should be even with the bottom thread within the cylinder. For optimum performance use Bombardier (Blue) shock fluid (P/N 503 190 103).
7. Grasp piston rod assembly and position the cylinder head 6 mm (1/4 in) away from the piston valve assembly, ensuring the oil flow passage hole within the rod is not obstructed. Slowly push the piston rod assembly into shock body until the cylinder head assembly bottoms on the cylinder counterbore. Do not tighten.
8. While holding the reservoir at a level higher than the shock, fill the reservoir with shock oil and allow the oil to gravitate downwards through the braided hose until the oil level rises to the top of the shock cylinder.

NOTE: Be sure not to allow oil level in reservoir to fall beneath height of Internal Floating Piston.

9. Reinstall bleed screw into Internal Floating Piston. Pour the excess oil in reservoir into waste container.

NOTE: Be sure that bleed screw O-ring is accounted for when reinstalling.

10. Reinstall reservoir end cap down into the reservoir approximately 25 mm (1 in). Install retainer circlip making sure it is firmly in place.
11. Loosely tighten down the remaining portion of the pressure valve assembly. With pliers, grasp the end cap by the pressure valve assembly and pull it up into place against the retainer circlip.
12. Using 1-1/4 in open face wrench loosely tighten cylinder head into the shock cylinder.

NOTE: During installation, some shock oil will overflow. Wrap a shop cloth around shock body to catch possible oil overflow. Fast installation of the piston rod and assembly may displace the floating piston from its original position. This must not occur if the damper is expected to perform as designed.

13. Purge any remaining air from the shock by grasping the end of the rods upper mount and stroke the rod, by its full length, in and out of the shock cylinder 4-5 times.

14. With the shock rod in its fully extended position (oil passage way blocked off) loosen and remove cylinder head assembly.
15. Replenish shock body with oil to the bottom of the threads within cylinder.
16. Reinstall and firmly tighten cylinder head securely into the shock cylinder.

NOTE: During installation, some shock oil will overflow. Wrap a shop cloth around shock body to catch possible oil overflow. Fast installation of the piston rod and assembly may displace the floating piston from its original position. This must not occur if the damper is expected to perform as designed.

17. Pressurize the shock reservoir, through the pressure valve, with nitrogen gas to the specified gas pressure.

NOTE: Adjust gas pressure to specified value indicated in shock specification. After being compressed, the piston rod should fully extend from the shock once the shock has been pressurized.

18. With the gas pressure pushing against the pressure valve end cap firmly tighten the pressure valve assembly and re-install the small button head screw.
19. Reinstall any bearing sleeves and/or bushings in the lower shock mount.

REAR SHOCK — 2002 MX Zx 440 LC — P/N 503 189 780

Disassembly

WARNING

Before servicing a gas shock it is important that all the gas pressure be discharged from the unit. Refer to the instructions listed below for the proper procedure of discharging the gas pressure from a shock. Protective eyewear should be worn to avoid risk of injury while servicing all gas charged mono-tube shocks.

1. Remove the shock from the vehicle.
2. Wash the shock body in parts cleaner; then dry with compressed air to remove sand and dirt.

WARNING

When using compressed air to dry components, protective eyewear **MUST** be worn to avoid risk of injury.

3. Remove bearing sleeve and/or bushings from lower shock mount eyelet. Secure the shock in a horizontal plane by its lower mount in a vise. The use of soft jaws is recommend to prevent damage or marks to the shock.

CAUTION: It is important that the gas shock be retained in the vise by the lower mount. Any other method of securing the shock body during these procedures may deform the shock body cylinder.

4. Remove the small button head screw from the pressure valve assembly found on the bottom of the reservoir.

5. Using a slotted screwdriver, discharge all gas pressure from the shock by loosening the pressure valve assembly two (2) full turns counterclockwise.

WARNING

Nitrogen gas is under extreme pressure. Use caution when releasing nitrogen gas from shock. Protective eyewear should be worn to avoid risk of injury.

CAUTION: Allow all the gas pressure to escape before proceeding with the removal of the pressure valve assembly. Pressurized gas could eject the valve assembly from the cylinder - resulting in bodily injury.

6. Using a 3/4" wrench loosen and remove reservoir end cap.
7. Reposition shock absorber to a vertical upright position in vise by its lower mount.
8. Remove the reservoir bleed screw located opposite to the reservoir end cap. Account for O-ring.
9. Remove the Internal Floating Piston from the reservoir by pushing the IFP with a push rod out of the reservoir. Account for wear band and O-ring.
10. Using a 1-1/4" open face wrench, fully loosen and remove cylinder head and remove rod assembly, placing it on a clean shop towel.

SECTION 07 - 2002 MX Zx 440 INFORMATION

11. Pour the oil out of the shock reservoir and main cylinder body into waste container. Discard old oil into an approved storage container and dispose appropriately. Never reuse damper oil during shock rebuild.
12. Clean the inside of the shock body using clean parts-cleaning solvent and blow dry using compressed air.
13. Place the shock piston rod upper mount in bench vise, begin piston and valve removal. Arrange parts removed in the sequence of disassembly.
14. Items to inspect:
 - a. Piston rod/rod spacer for straightness, nicks or burrs.
 - b. Cylinder Head Assembly/DU Bearing/Seals and Scraper - clean, inspect, or replace.
 - c. Inside of shock body for scratches, burrs or excessive wear.
 - d. Teflon piston and I.F.P wear band for cuts, chipped or nicked edges, or excessive wear.
 - e. O-rings for nicks, cuts, or cracks.
 - f. Valve discs for kinks or waves.
 - g. Braided hose and fittings for kinks, tears, worn or loose threads.

Should any of these items be in question replacement is recommended.

Assembly

1. Place the piston rod upper mount into the vise. Reassemble damper rod assembly in the reverse order of disassembly. Special attention should be paid to the order of the Rebound and Compression disc (shim) stacks, ensuring that they are in the same order prior to disassembly. Tighten the lock nut to 21-27 N•m (15-20 lbf•ft) of torque.

CAUTION: DO NOT OVER-TORQUE. If excessive torque is applied, damage to the piston and valves will occur.

2. Secure the shock in a horizontal plane by its lower mount in a vise. The use of soft jaws is recommended to prevent damage or marks to the shock.

CAUTION: It is important that the gas shock be retained in the vise by the lower mount. Any other method of securing the shock body during these procedures may deform the shock body cylinder.

3. Apply a thin film of oil onto the floating wear band and O-ring, and slowly install the floating piston into the bottom of the reservoir body.
4. Using the push rod, push the Internal Floating Piston down into the reservoir to a depth of 94 mm (3.7 in) from the bottom of reservoir body.
5. Using a 3/4" wrench reinstall and tighten reservoir end cap into reservoir body. Securely tighten pressure valve assembly into reservoir end cap.
6. Reposition shock absorber to a vertical upright position in vise by its lower mount.
7. Fill the shock body with 240 mL (8 oz U.S.) of shock oil. The shock oil will flow through the passage port and simultaneously fill the reservoir to its top. For optimum performance use Bombardier (Blue) shock fluid (P/N 503 190 103).
8. Reinstall and securely tighten bleed screw into reservoir body.
9. With the cylinder head assembly pushed down against the piston, carefully, insert the piston rod and assembly into the cylinder; Slightly oscillating the piston rod to allow piston to enter shock body bore.
10. Slowly push the piston rod and assembly into shock body until the cylinder head assembly bottoms on the cylinder counterbore. Slight up and down movement may be required to allow all air to pass through piston assembly.

NOTE: During installation, some shock oil will overflow. Wrap a shop cloth around shock body to catch possible oil overflow. Fast installation of the piston rod and assembly may force air into the shock and get trapped beneath the piston. This must not occur if the damper is expected to perform as designed

11. Using 1-1/4" open face wrench tighten cylinder head securely into the shock cylinder.
12. Pressurize the shock reservoir, through the pressure valve, with nitrogen gas to the specified gas pressure.

NOTE: Adjust gas pressure to specified value indicated in shock specification. After being compressed, the piston rod should fully extend from the shock once the shock has been pressurized.

13. Reinstall the small button head screw in the pressure valve assembly and tighten securely.
14. Reinstall any bearing sleeves and/or bushings in the lower shock mount.



2002 SKI-DOO MX Zx RACING TIP SHEET

SKI-DOO RACING, 7575 BOMBARDIER COURT, WAUSAU, WI 54402-8035
Number: 01 December 6, 2001

WARNING

This information relates to the preparation and use of snowmobiles in competitive events. Bombardier, Inc. and Bombardier Corporation disclaim liability for all damages and/or injuries resulting from the improper use of the contents. We strongly recommend that these modifications be carried out and/or verified by a highly skilled professional racing mechanic. It is understood that racing or modifications of any Bombardier made snowmobile voids the vehicle warranty and that such modifications may render use of the vehicle illegal in other than sanctioned racing events under existing federal, provincial and state regulations.

Timing Switch (fuel octane switch)

Check Timing Switch to make sure it has been wired correctly. The BLACK wire connects to the 100-octane terminal (closest to steering post), the white wire connects to the center terminal, and the green wire connects to the 108+ terminal (furthest from the steering post).

Recommended Fuel vs. Switch Position vs. Jetting

The recommended fuel is 114 octane. Warm up the sled with the timing switch in the 91-octane position. This will allow the exhaust pipe to heat up sufficiently to avoid pipe surge. After the pipe has been warmed up properly, switch to the 100-octane position. It is not necessary to use the 108+ octane setting when using 114-octane fuel. Max performance is achieved using the 100-octane setting. Proper jetting is 240 PTO and 230 MAG when using 114-octane fuel at 32°F. When using lower octane fuel, increase jet size accordingly. Rejetting will be required with temperature changes.

Jet Needle

At approximately 32°F and below, raise the Jet Needle so the needle clip is in the no. 4 position.

Drive Clutch Pins

Check the pins in the drive clutch for proper threads. Some clutches have a mixture of standard thread pins and metric thread. The Ski-Doo Race Support Truck has the metric pins with set-screws available. If you determine your clutch has some of each, either switch to the old style standard pins or replace the standard pins with the new metric pins. In the future, all pins will be metric. If you experience high engine RPM, add 1 to 2 short screws to each pin. The proper engine RPM for Max performance is between 8300 and 8500 RPM.

SECTION 07 - 2002 MX Zx 440 INFORMATION

Coolant Restrictor Plug

Check the hose between the engine thermostat housing and the coolant fill tank. Inside the hose is a restrictor plug, which limits the amount of coolant flow from the engine to the fill tank. Due to engine vibration, the clamp, which holds the restrictor in place, becomes loose and therefore allowing the plug to move and fall into the outlet in the bottom of the fill tank. If the plug is still in the hose, reposition the clamp between the plug and fill tank and retighten, therefore reducing the hose diameter as not to allow the plug to move to the fill tank. If the plug is missing from the hose, remove the coolant from the fill tank, disconnect the coolant hoses at the tank. Turn the tank upside down until the plug comes out. Secure plug in hose as described above. Connect all coolant hoses and refill coolant to proper level. Periodically, check to make sure plug is secure.

Loose Bolts – Suspension

After each heat or race, check the torque on all suspension fasteners. Give special attention to the fasteners that hold the shocks in place. If loose nuts or bolts are found, torque to proper specification.

Chain Tensioner Bolt

Check the countersunk in the Chain Tensioner Block. To prevent the bolt from coming loose, remove the bolt, clean the threads, and apply a small amount of Loctite to the bolt threads and torque to proper specification. Do not apply too much Loctite, as this will interfere with the adjustment of the tensioner bolt.



2002 SKI-DOO MX Zx RACING TIP SHEET

SKI-DOO RACING, 7575 BOMBARDIER COURT, WAUSAU, WI 54402-8035
Number: 02 January 10, 2002

⚠ WARNING

This information relates to the preparation and use of snowmobiles in competitive events. Bombardier, Inc. and Bombardier Corporation disclaims liability for all damages and/or injuries resulting from the improper use of the contents. We strongly recommend that these modifications be carried out and/or verified by a highly skilled professional racing mechanic. It is understood that racing or modifications of any Bombardier made snowmobile voids the vehicle warranty and that such modifications may render use of the vehicle illegal in other than sanctioned racing events under existing federal, provincial and state regulations.

2002 MX Zx 440 Rear Shock

Some racers have indicated that the rear shock is too stiff. The Ski-Doo Race Dept. has developed a calibration that softens the high-speed compression. Dealers have been advised of this by way of a Service Bulletin and Service Centers have been set up to accommodate all racers. Contact your local dealer for more information. The Ski-Doo Race Support Truck has copies of this bulletin and will revalve the rear shock at a cost of \$25.00 US. There is no cost to have one of the Service Centers perform this work, although the racer must pay shipping both ways. Contact the Service Center before having work performed.

Service Center (US) Carver Performance

Rt. 5 Box 21
Thief River Falls MN 56701
Phone: 1-888-349-7469

Canada

Pro -Tech Suspension

2575 Remembrance Blvd.

Lachine QC H8S 1X4

Phone: 514-828-5058

When removing the rear suspension, it is a good idea to remove the rear shock first. Failure to do so may lead to burring or marring of the shock shaft when it comes in contact with the rear swing arm. When installing the rear shock, pay close attention that the shock reservoir faces down. Failure to do so could result in suspension and track failure.

MX Zx 440 Sno X Race Set-up

Fuel: 114 octane

Jetting: 230 PTO 220 MAG, this is at 32°F.

Raise the Jet Needle 1 pos (#4)

Fuel Switch: Start race on 91, then switch to 100.
Do not use 108 position.

Drive Clutch:

Stock Spring

Stock arms

296 Ramp

2 small set screws in each arm

Driven Clutch

54-44 cam

26 lbs preload, B5

Gearing: Stock 21/43

Contingency Program

The 2001-2002 Contingency Program is available for viewing on the Ski-Doo Website at Ski-Doo.com under Racing Zone.

Good Luck from the Ski-Doo Race Dept.

TABLE OF CONTENTS

SNO CROSS.....	08-2
HILLCROSS	08-2
HILL CLIMBING.....	08-3
DRAG RACING (ICE AND GRASS)	08-3
SPEED RUNS	08-5
OVAL RACING.....	08-5
SUGGESTED SPARE PARTS.....	08-7
EQUIVALENT WEIGHTS AND MEASURES CHART	08-9
FUEL/OIL RATIO CHARTS	08-10
STOCK CLASS PREPARATION	08-15
TECHNICAL DATA.....	08-16
Supplement for model: REV 600 2003.....	08-16
Supplement for model: REV 800 2003.....	08-17
Supplement for model: SUMMIT 800 2003.....	08-18
OPTIONAL RACE TRACKS.....	08-19
STOCK CLASS ONLY	08-19

SECTION 08 - COMPETITION PREPARATION

These are general guide lines for preparing a stock REV chassis for various forms of competition. Refer to the appropriate section of the book for more detailed information and tuning components.

SNO CROSS

Chassis

- The ideal chassis to use is the MX Zx 440 REV chassis. This chassis is specifically designed for Sno Cross racing.

Front Suspension

- The 2003 MX Zx 440 REV comes equipped with remote adjustable shocks for both high and low speed compression. Use the low speed shock adjusters to control the small or slow bumps and adjust the high speed adjusters to control big or fast bumps to prevent the suspension from bottoming out.
- Stock spring rate is 18.4 N/mm (105 lbf/in), and there is lighter and stiffer springs available. Adjust spring preload between 0 and 13 mm (0 in and 1/2 in) of suspension ride in (sag) when the rider is standing in race position. If you have to adjust the spring pressure more than 38 mm (1-1/2 in) of preload on the shock, you may want to change to a stiffer spring.
- A 13 mm (1/2 in) diameter anti roll bar comes standard. Many racers choose to remove the anti-roll bar. If you remove the bar, make sure to cover the holes in the bulkhead area with aluminum or plastic plate as to prevent snow from entering. If you wish to use a larger bar, the 600 & 800 REV use a 16 mm (5/8 in) diameter. Those are the only options available to date.

Center Suspension

- Set spring pressure to light settings and adjust shocks adjusters to control high and low compression to prevent bottoming out. If the rear of the sled wants to pass the front while in the air, reduce spring pressure and/or shock compression.

Rear Suspension

- Again, the rear shock has external adjusters for high and low speed compression. Set adjusters so the suspension does not bottom out. This adjustment must be for different courses.

- Adjust spring pressure, with the rider in place, so the ACM block is in the center of the coupling window. Stiffer and softer springs are available. Adjust the ACM block to control the amount of weight transfer according to conditions.

Fuel and Carburetion

- Recommended fuel octane is minimum 100. Be aware that only unleaded fuel is legal to use. Use the jetting chart on the belt guard as a guideline. When installing 0.3 mm (.012 in) base gasket, you are able to increase octane and performance. Higher altitude requires lower fuel octane. Example, 1829 m (6000 feet), maximum 100 octane.

Skis

- The ski loops do not meet ISR guidelines, therefore modification to the loops must be made before using them in competition. The loop must be rapped and secured with a foam or rubber tube to meet the 25 mm (1 in) minimum width and also fold over the front of the ski tip and secured. Failure to do so may result in disqualification.

Snow Flap

- Some circuits are requiring that the snow flap be long enough to touch the ground when the rider is not on the sled. An extension may be required. Best extension material is plastic sheet or another snow flap.

HILLCROSS

Special Rules

- The stud rule is the same as Sno Cross. Care must be taken when installing studs as not to place them where they will cause damage to heat exchanger or tunnel. Tunnel protectors of the correct height are required.
- Most circuits have different classes from Stock to Modified, be sure to check with the Race Circuit for specific rules and guidelines regarding each class.

Suspension

- Use Sno Cross spring and shock set up.

Track

- Best performance and speed is achieved by installing a 136" x 15" with 1.75" lug height.
- 136" Track extension kits are available in limited quantities. Contact Ski-Doo Race Dept. for availability and information.

Transmission

- Clutch setups will be similar to Sno Cross. Due to higher speeds than Sno Cross, an increase in gearing is required, depending on length and steepness of course.

HILL CLIMBING

Front Suspension

- Use soft springs. You want the skis to compress very easily and not transmit any upward force into the chassis.
- Use minimal compression and medium rebound dampening in the shock absorbers and, the gas pressure can be reduced to 1379 kPa 200 PSI.

Center

- Use medium spring pressure. You need some track pressure for traction but the front arm must be able to compress easily to absorb bumps.
- Use minimal compression and medium rebound dampening in the shock absorbers.
- The limiter strap should be fairly short to keep front end lift to a minimum. Two to three inches of lift is plenty. A balance must be maintained between having enough traction and keeping the front end down for steering.

Rear Suspension

- Spring pressure should be kept firm in order to reduce weight transfer and help keep the front end down on the ground.
- Medium amount of compression and enough rebound to control the stiffer spring settings to prevent the rear of the machine from "pogoing".

Track

- Use a "finger" type track with a 1.75" to 2.00" lug height profile. Beginning of season or fresh snow, use a track with a 1.75" lug height and later in the year when the hill has a lot of ice, use a 2.00" lug height track.
- Use a 144" X 15" track for best performance.
- For information regarding chassis extension kits, contact Ski-Doo Race Dept.
- Check with the race organization for rules regarding changing of tracks.

Transmission

- Good backshifting is important. Use a few pounds more than normal preload on the driven pulley.
- Adjust the TRA to maintain optimum RPM.

Driving Style

- Contrary to popular belief, constant full throttle is not always the fastest way to the top. Use your thumb to adjust for the conditions. Sometimes you need to back out of it to keep the track from spinning excessively. You need to keep your momentum up but you must keep the sled on the ground so your track is hooked up and the skis can steer you around any obstacles.

DRAG RACING (ICE AND GRASS)

Special Rules

- Snow flap must be retained by 3 mm (1/8 in) diameter cable.
- Double limiter straps are required by many organizations.

Front Suspension

- Lower the ride height by installing shorter springs, limiter straps or spacer inside the shock to limit suspension travel. Maximum shock length is 360 mm (14.7 in) with 15 mm (.59 in) of spring preload.
- Trim the rubber blocks under the ski legs to reduce and adjust the amount of heel pressure on the ski.
- Use steel runners on the grass and stock trail carbide runners on the ice.

SECTION 08 - COMPETITION PREPARATION

Center

- Use stock springs but limit suspension travel with limiter straps or stops to 76 mm (3 in), measured from the front arm to bumper stop.
- Shorter limiter straps will be required. On grass, more weight transfer can be used to keep the weight off the skis. On ice, run the limiter very short to keep ski lift to a minimum.

Rear Suspension

- Replace stock springs with (P/N 486 099 100 RH) and (P/N 486 099 300 LH). These springs have a higher spring rate but softer preload. Limit suspension travel by straps or stops to 102 mm (4 in), measured between the rear arm and bumper stop. Adjust the ACM coupling block to full couple.
- Grass: Soften preload to help weight transfer and keep the skis from dragging.
- Ice: Use a lot of preload to help keep the front end down for better top speed at the end of the chute.
- Remove slider shoes (HyFax). Add idler wheels of correct size to prevent track from contacting rails

Traction

- Most rules limit maximum stud height to 19 mm (3/4") over the tallest part of the track. Taller tunnel protectors will be required.
- Generally, fewer studs are required on grass than on ice. Also, less studs are needed on good, thick sod or hard clay. More studs will be needed on loose grass, dirt and sand.
- Grass: Four steel picks per bar (4 x 48 pitches on 121" track = 192 studs). Large horsepower machines may need more studs. Exchange some picks for grass hooks on looser track surfaces. Use "chisel" style studs. They have a wider pro-file but are still sharp on the ends.
- Ice: Stud quantity is directly related to horsepower on the ice. Up to about 80 HP, 4 to 5 ice picks per pitch should be used for a total of 200-250 studs. 80 to 105 HP should need 6 to 7 picks per pitch for a total of 300-350 studs. Over 110 HP will require 7 to 8 picks per pitch and possibly hooker plates welded to the track guides.

NOTE: The installation of hooker plates will require modification to the tunnel protection system and should be approached with caution.

- 51 mm (2 in), two hole angled aluminum backer plates should be used when many studs are required. They should form the basis of your stud pattern with single, square, flat or angled backer plates used in between.
- Studs should be placed so the pattern does not repeat itself for 4 to 6 pitches.

Transmission

- Gear for about 10% over the actual speed you will run in the race. On grass, your upper sprocket should be about two teeth smaller than on the ice.
- Always stay with the same belt type and size, belt deflection, and center to center distance. Have several belts of the same size broken in and ready to race. Don't test with one belt and then throw on a new one for race day.
- Keep the clutches clean! The pulley faces and belt should be lightly sanded and wiped down with acetone before every run. Excessive pulley heat indicates belt slippage and you may need to recalibrate your clutch to squeeze the belt harder.
- Torque is what overcomes resistance to rolling. Normally peak torque is about 200 to 300 RPM below peak horsepower. When accelerating at the start of a race, clutch to peak torque and let the RPM climb to max horsepower by the end of the run.
- Tune your clutches so that you run best for the final which means everything will be heat soaked. If your sled requires different set ups between early runs when everything is cold and later runs, know what to change and when to change it. Test under a variety of conditions so you are prepared for any track and race conditions.

Cooling

- Install a pair of hydraulic quick couplers in the coolant hoses at a convenient location on the sled. Make a cooling cart using a cooler filled with ice and several winds of copper tubing inside (or another type of heat exchanger) connected to an electric pump and another set of quick couplers. Connect your sled to this mobile refrigerator between runs to circulate coolant through the system and cool the engine down. Cool the engine to the same temperature every time so your runs are consistent.

For more drag racing and setup information contact Racing Dept. by fax at (715) 847-6869, phone (715) 848 4971.

SPEED RUNS

Generally, a speed run sled will be set up very similar to an ice drag sled with the following differences.

- Some organizations do not allow lowering for stock class sleds. Check your rules. Shorter springs may be an option to try.
- Because holeshots are not important, engagement speed does not have to be set at 5000 RPM. Top speed at the end of the course is the only concern.
- Chaincase gearing can be set for high theoretical top speeds. Use the largest top and smallest bottom sprocket available. This will keep the belt low in the drive pulley which lowers the belt and countershaft speed which makes the transmission more efficient.
- As few studs as possible should be used. It takes energy to push a stud into the ice and pull it back out again. Since holeshots are not important, use only enough studs to maintain control at top speed.
- Use standard trail carbide runners with the sharp edge worn down a bit. This way you will have steering control without sacrificing speed.
- Run with a very short limiter strap and soft center spring. This will reduce the track approach angle which helps top speed.

OVAL RACING

Special Rules

- Rear of tunnel must be enclosed per specifications in the I.S.R. rulebook.
- Snowflap must be retained by chains or 3 mm (1/8 in) diameter cable.
- Tail light AND brake light element must be on at all times! Add a jumper wire inside the taillight assembly.
- Any glass lenses must be taped over with clear tape.

Front Suspension

- Relocate ski mount in spindle by drilling out the predrilled hole 10 mm (.39 in) behind stock mounting hole.
- Lower the ride height to the two inch minimum travel requirement. Shorter springs are available.
- Valve shocks to light compression and medium rebound
- Camber: Left = 0 degrees
Right = Negative 2 to 4 degrees
- Verify ski toe out, about 3 mm (1/8 in) at the carbide edge.
- Steering ball joints should have as many jam nuts added as will fit between the tie rod and the ball joint. This helps prevent bending of the threaded portion of the ball joint.

Center

- Use spring with soft preload and compression and medium rebound.

Rear Suspension

- Lower the ride height to the 51 mm (2 in) minimum travel requirement.
- Install a 4th idler wheel on the rear axle.
- Stiffer springs and firm preload may be required to reduce weight transfer and help keep the skis on the ice. If the handling is generally good but the inside ski is lifting, increase the right rear spring preload.
- Remove non guide clips and install taller track guides on the right side of the track or use designated oval track.

SECTION 08 - COMPETITION PREPARATION

Traction

- Most rules limit maximum stud height to 3/8" over the tallest part of the track. Track cutting is illegal. A camoplast oval track is available (P/N 700 9844), it has 19 mm (3/4 in) lug height and tall guide clips for oval racing.
- Use a thin profile, sharp tipped stud for hard ice conditions. If the track conditions get sloppy, exchange some picks for a chisel or wedge type stud.
- Seven picks per bar for a total of 336 studs will be required for all sleds up to about 100 HP. Bigger sleds may require more picks and/or hooker plates.
- Use 51 mm (2 in), 2 hole angled aluminum backer plates for the majority of your pattern, especially on the outside belts. The right hand belt will need a 51 mm (2 in) plate on every pitch. Fill in the pattern with 25 mm (1 in) square backer plates. The pattern should not repeat itself for at least 5 pitches.
- Use a good quality square bar carbide runner with 254 mm (10 in) of carbide for starters. As you gain experience, try 356 mm (14 in) of carbide for more front end bite.
- Studs and carbides need to be SHARP! The carbide must shave your fingernail when scraped across and studs must prick your finger.

Controls

- You will probably be more comfortable in the corners if you make a curved extension for the left side of the handlebars. Many drivers make a new set of bars from the same size tubing and custom bend it to fit their preference. (Check your rule book for requirements on handlebars).
- You may also want to fabricate a stirrup for your right foot.

Transmission

- You need aggressive shifting to get a good hole-shot but you also need good backshifting. Here again, testing is the key to success.
- Use the lowest TRA setting that still allows you to maintain correct RPM when exiting the corners.
- Gear for the speed you will go on the course.
- Break in several belts of the same type and size and set up your pulleys to work with these belts.
- Maintain your clutches on a weekly basis. A clean, free moving driven pulley is important to good backshifting. Clean the pulley faces with acetone on a regular basis.

Physical Conditioning

- While a well set up sled will be easier to drive than a poor one, it still takes good arm strength to turn a stocker with aggressive carbide. Train your upper body for strength and endurance. A good overall conditioning program that also works your legs and respiratory system is a smart idea. While it may not seem like 3 lap heats are very long, 10 lap finals on a short track with tight corners can really wear you down.

RACE CIRCUITS

Remember it is the driver and team's responsibility to have the sled race-ready in accordance with the rules of the circuit you race in. All races approved for Ski-Doo's Winners Circle contingency awards are governed by the general rules laid out in the ISR annual handbook. It is common practice for the various race associations across North America to modify the ISR rules for local use. This does result in conflicting standards and therefore every driver must carefully check the rules.

Contact the following circuits for detailed race rules.

SECTION 08 - COMPETITION PREPARATION

ISR	International Snowmobile Racing	262-335-2401 PH 262-335-9440 Fax
WSA	World Snowmobile Association	763-493-9900 PH 763-493-9910 Fax
CSRA	Canadian Snowcross Racing Association	905-476-7182 PH 905-476-7157 Fax
ASRA	American Snowcross Racing Association	905-476-7182 PH 905-476-7157 Fax
RMR	Rock Maple Racing	802-368-2747 PH
USSA	U.S. Snowmobile Association	262-252-2000 PH
WSA Pro Ice	World Snowmobile Association Pro Ice	763-428-3800 PH 763-428-3897 Fax
SCM	Super Competition Motorsport	450-794-2298 PH 450-794-2450 Fax
PRO	Power Sled Racing Organization	315-827-4849 PH
NSRA	National Snowmobile Racing Assn.	815-789-4266 PH
MSDRA	Michigan Snowmobile Drag Racing Association	810-989-9554 PH
RMXCRC	Rocky Mountain Cross Country Racing Circuit	208-887-4884 PH
BEST	Big East Snocross Tour	315-768-3343
MIRA	Midwest International Racing Association	989-257-5264
RMSHA	Rocky Mountain Snowmobile Hillclimb	406-748-3111
NIDRA	Northern Illinois Drag Racing Assn.	517-522-8584
NWSA	Northwest Sno-cross Assn.	425-774-0505
PEP	Performance Event Promotions	416-446-6184 PH

PARTS SUPPORT

The Ski-Doo factory support trucks will be on hand at most major Snowcross, grass drag and oval events across the U.S. and Canada. The purpose of these trucks is to provide parts, and technical support for all racers racing Ski-Doo snowmobiles.

The Ski-Doo race support trucks carry an extensive inventory of parts, however it is always best to be self contained and not to count on anyone but himself for parts support.

SUGGESTED SPARE PARTS

You should have a self-contained parts supply. The factory parts truck won't always be there to back you up.

- parts book
- piston assembly and circlips
- tuned pipe
- radiator cap
- gas cap
- drive belts
- carb. inlet needle and seat
- drive and driven clutch springs
- driven clutch rollers
- TRA adjuster screws and nuts
- drive clutch retainer bolt
- brake fluid
- steering tie rods and ball joints
- ski shock assembly
- skis and carbide runners
- ski bolt and nut
- light bulbs
- windshield and O-rings
- tether cord and switch
- handlebars and grips
- shop manual/specification booklet
- engine gaskets, seals and O-rings
- rewind assembly and components
- exhaust springs
- spark plugs
- spark plug caps and wires
- main jets
- chaincase chain and sprockets
- TRA clutch puller and forks
- TRA clutch rollers
- driven pulley circlip and keys
- brake lever
- front suspension replacement parts
- brake pads
- steering arms
- throttle lever and housing

SECTION 08 - COMPETITION PREPARATION

- tail light assembly
- hood latch rubber
- synthetic chaincase oil.

Things to DOO Between Heats:

- carefully remove ice and snow build up front and rear suspension
- inspect suspension components
- check/replace studs
- check tightness of all suspension bolts
- check all idler wheels for missing rubber and condition of bearings
- lube steering and front suspension ball joints
- check chain tension and oil level
- check clutch alignment and clean pulley faces
- coolant hose condition/routing
- check electrical connections
- inspect track for damage and missing guide clips
- check skis and carbides
- check ski toe out
- check brake disc and pad condition
- grease all zerk fittings
- check track tension and alignment
- check brake fluid and operation
- inspect drive belt
- check throttle and oil cable and
- check light bulbs.

Replace any tools or parts used from race vehicle supply.

Shut off fuel before leaving for the night.

SECTION 08 - COMPETITION PREPARATION

EQUIVALENT WEIGHTS AND MEASURES CHART

LINEAR MEASURE	
1 inch = 25.4 millimeters (mm)	1 millimeter = .03937 inch
1 inch = 2.54 centimeters (cm)	1 centimeter = .3937 inch
1 foot = .3048 meter (m)	1 meter = 3.2808 feet
1 yard = .914 meter (m)	1 meter = 1.093 yards
1 statute mile = 1.609 kilometers (km)	1 kilometer = .6214 statute mile

WEIGHT	
1 Ounce = 28.35 Grams (g)	1 Gram = .03527 Ounce
1 Pound = .4536 Kilogram (kg)	1 Kilogram = 2.2046 Pounds
1 Ton = .907 Metric Ton (t)	1 Metric Ton = 1.102 Tons

VOLUME	
1 Fl. U.S. Ounce = 29.574 Milliliters = .2957 Deciliter = .0296 Liter	
1 Fl. U.S. Pint = 473.18 Milliliters = 4.7316 Deciliters = .4732 Liter	
1 Fl.U.S. Quart = 946.35 Milliliters = 9.4633 Deciliters = .9463 Liter	
1 U.S. Gallon = 3.785 Liters	
1 Cu. Inch = 16.387 Cu. cm	
1 Cu. Centimeter = .061 Cu. Inch	
1 Cu. Foot = 2.831.16 Cu. Cm.	
1 Cu. Decimeter = .0353 Cu. Foot	
1 Cu. Yard = .7646 Cu. Meter	
1 Dry Quart = 1.101 Liters	

TEMPERATURE	
32° Fahrenheit = 0° Celsius	$^{\circ}\text{F} = 9/5^{\circ}\text{C} + 32$
0° Fahrenheit = -17.8° Celsius	$^{\circ}\text{C} = (^{\circ}\text{F} - 32) \times 5/9$

SPEED	
1 MPH = 1.61 km/h	

SECTION 08 - COMPETITION PREPARATION

FUEL/OIL RATIO CHARTS

50/1

METRIC (SI)

500 mL of oil + 25 L of fuel = 50/1

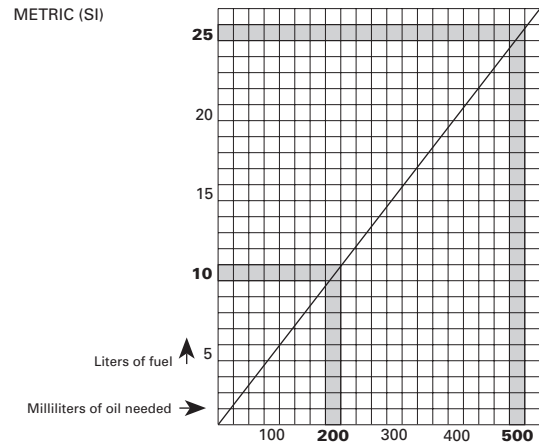

IMPERIAL

16 oz of oil + 5 Imp. gal of fuel = 50/1

500 mL of oil + 5.5 Imp. gal of fuel = 50/1

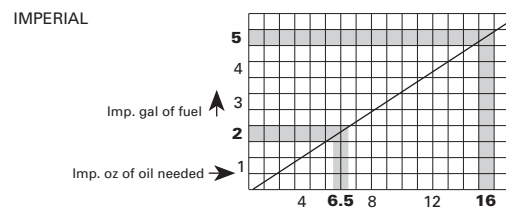

UNITED STATES

13 oz of oil + 5 U.S. gal of fuel = 50/1

500 mL of oil + 6.6 U.S. gal of fuel = 50/1

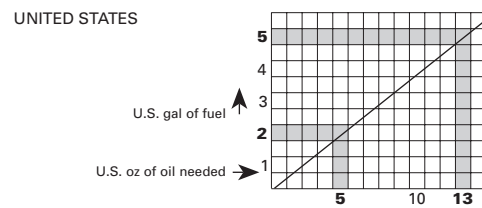

A00A1WJ

SECTION 08 - COMPETITION PREPARATION

40/1

METRIC (SI)

500 mL of oil + 20 L of fuel = 40/1

METRIC (SI)

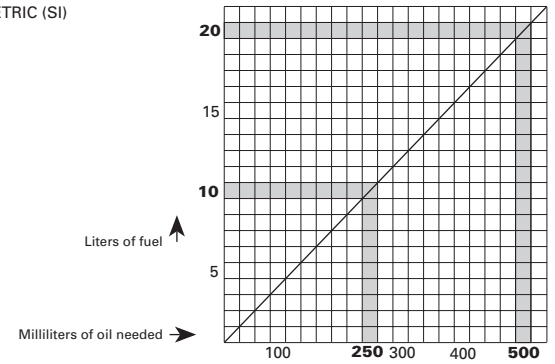

IMPERIAL

16 oz of oil + 4.0 Imp. gal of fuel = 40/1

500 mL of oil + 4.8 Imp. gal of fuel = 40/1

IMPERIAL

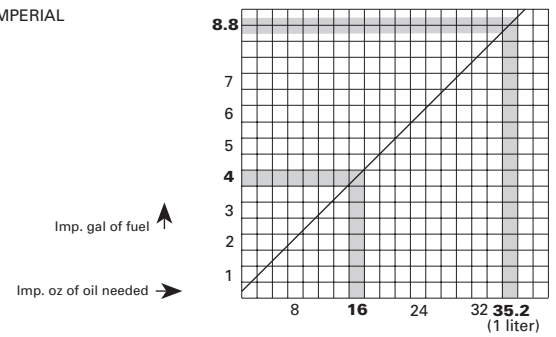

UNITED STATES

500 mL of oil + 5.3 U.S. gal of fuel = 40/1

UNITED STATES

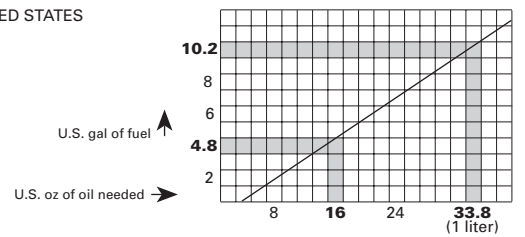

A00A2WJ

SECTION 08 - COMPETITION PREPARATION

33/1

METRIC (SI)

500 mL of oil + 16.5 L of fuel = 33/1

METRIC (SI)

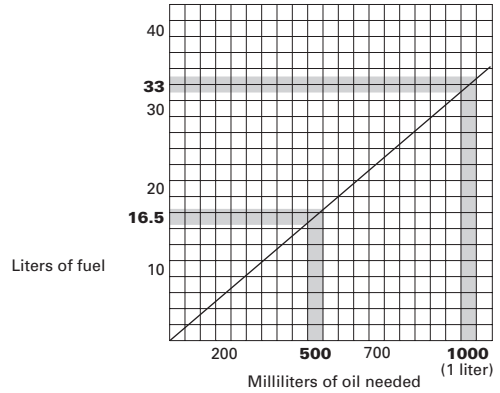

IMPERIAL

24 oz of oil + 5 Imp. gal of fuel = 33/1

500 mL of oil + 3.6 Imp. gal of fuel = 33/1

IMPERIAL

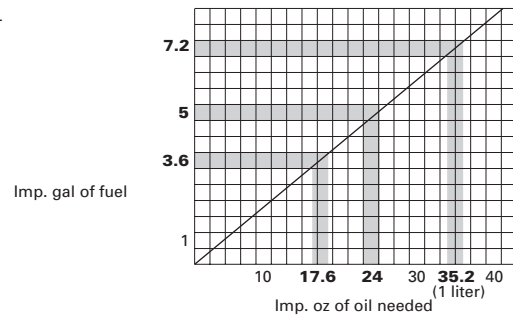

UNITED STATES

19.4 oz of oil + 5 U.S. gal of fuel = 33/1

500 mL of oil + 4.4 U.S. gal of fuel = 33/1

UNITED STATES

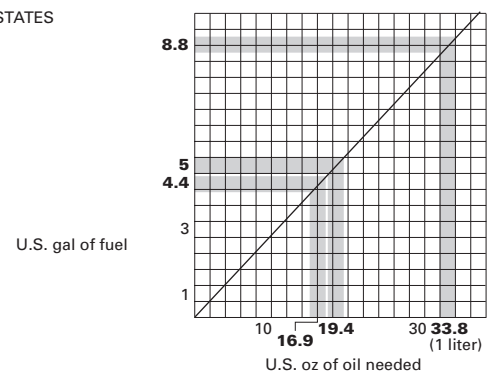

A00A6KJ

SECTION 08 - COMPETITION PREPARATION

25/1

METRIC (SI)

500 mL of oil + 12.5 L of fuel = 25/1

METRIC (SI)

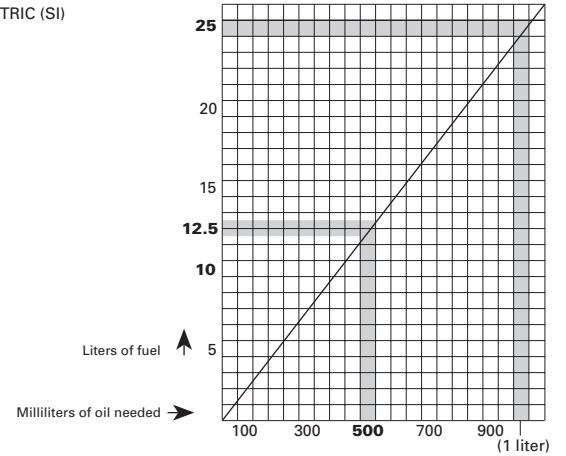

IMPERIAL

16 oz of oil + 2.5 Imp. gal of fuel = 25/1

500 mL of oil + 2.7 Imp. gal of fuel = 25/1

IMPERIAL

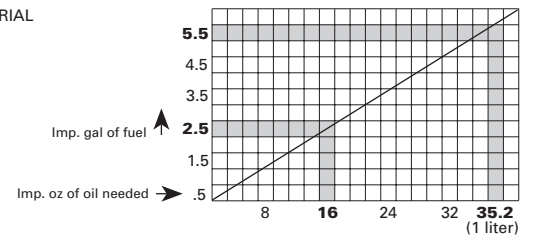

UNITED STATES

15 oz of oil + 2.8 U.S. gal of fuel = 25/1

500 mL of oil + 3.2 U.S. gal of fuel = 25/1

UNITED STATES

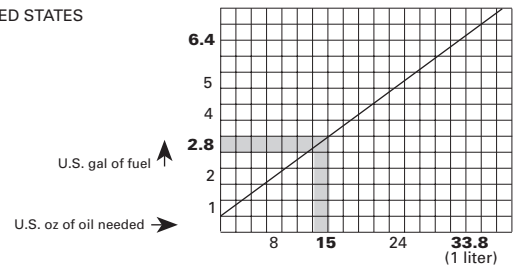

A00A2YJ

SECTION 08 - COMPETITION PREPARATION

20/1

METRIC (SI)

500 mL of oil + 10 L of fuel = 20/1

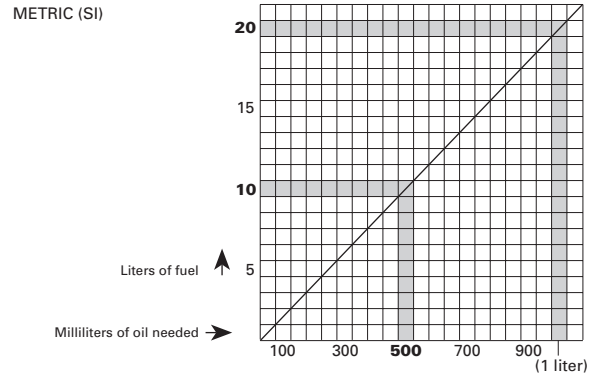

IMPERIAL

16 oz of oil + 2 Imp. gal of fuel = 20/1

500 mL of oil + 2.2 Imp. gal of fuel = 20/1

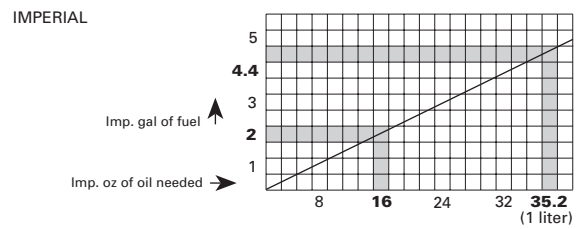

UNITED STATES

16 oz of oil + 2.4 U.S. gal of fuel = 20/1

500 mL of oil + 3.2 U.S. gal of fuel = 20/1

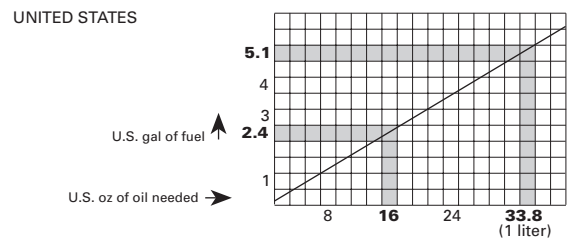

A00A2ZJ

STOCK CLASS PREPARATION

NOTE: Any machining and/or grinding is illegal in stock class racing. Keep your machine legal!

1. Remove and disassemble the engine according to correct *Shop Manual* procedures.
2. With the crankshaft resting in the lower half of the crankcase, set up a dial indicator and check the run out of the crankshaft at both ends. You should see no more than 0.05 mm (0.002 in) run out. If you have the capability, adjust the crankshaft as close to perfect as possible.

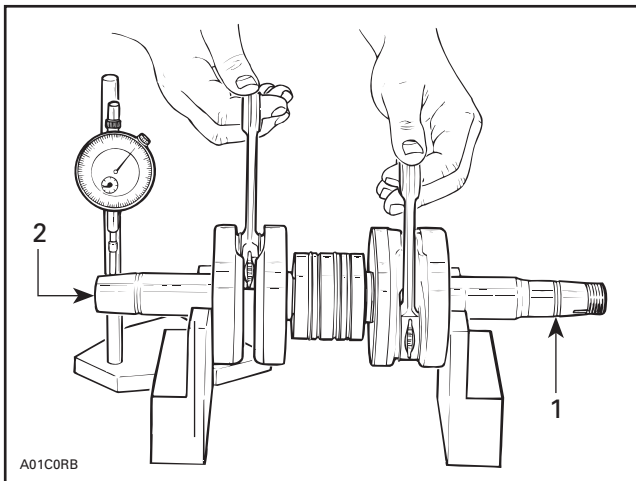

1. Measure behind the key
2. Measure at 6 mm (1/4 in) from edge

3. Set your cylinder base gaskets and cylinders on the upper half of the crankcase, and lightly torque the cylinders to the half. Be sure to install exhaust manifold on the cylinders before tightening them to the upper crankcase half to ensure the same position of the cylinders on final assembly.

Check the match of the gaskets and cylinders to the base; match them perfectly with a die grinder in the areas of transfer port passages. Also check for any over lap of the exhaust manifold gaskets where the exhaust manifold joins the cylinders. Before reassembling make sure that parts are free of any dust or particles.

4. Check piston to cylinder clearances, ring end gap, cylinder taper and out-of round.
5. Assemble the engine using the correct sealants where needed.

Rotary valve timing should be set with the closing edge as close to specs as possible or slightly higher.

NOTE: Refer to chart page.

6. The engine should be pressure-tested for air leaks. It should hold 6 PSI for 6 minutes with no more than a 1 PSI/min. loss.
7. Lube the rewind and inspect the rope for frays or cuts.
8. Oval racing must use taillight, brake light element on continuously (jumper from taillight wire terminal to brake light terminal on taillight assembly), regulator, tachometer, and temperature gauge.
9. Synchronize carburetors so that they open precisely together and ensure that the cut aways of the slides clear the inlet bores of the carburetors. After carb. adjustment, adjust oil injection pump.
10. On RAVE valve-equipped engines, check for free movement of the RAVE valve mechanism. Check the passageways between valve piston and exhaust port for any carbon buildup.

Adjust RAVE preload. It is better to have the valve open a little earlier than later.

NOTE: Pump fuels can be oxygenated or contain alcohol. Have your fuel tested prior to the race.

Do not use fuel de-icers.

11. Tie wrap ignition wire connectors together.
12. Adjust carburetors for atmospheric conditions. (See ENGINE PREPARATION section).
13. Break in a new engine before racing it. Performance can be gained by getting some run time on the engine. Ten hours of break-in is recommended.

SECTION 08 - COMPETITION PREPARATION

TECHNICAL DATA

Supplement for model: REV 600 2003

MODEL: REV 600 2003					
RACING TYPE		-GRASS DRAGS-			
	Maximum horsepower *	① RPM	7600-7700		
C A R B U R E T O R	Carburetor type				
			<i>PTO</i>	<i>CENTER</i>	
	Main jet	foam/paper type filters	400	400	
	Needle		<i>std</i>	<i>std</i>	
	Needle clip position (use a plastic washer to raise the needle) P/N 404 137 600				
	Slide cut-away		<i>std</i>	<i>std</i>	
	Pilot jet	P/N 404 110 300	25	25	
	Needle jet				
	Pilot screw adjustment	± 1/8 turn	2.0	2.0	
	Needle valve		<i>std</i>	<i>std</i>	
	Fuel		<i>minimum 100 octane</i>		
D R I V E R A T I O	Drive ratio		21-43		
	Chain		70 links <i>std</i> P/N 504 152 032		
	Drive pulley	Type of drive pulley		TRA III	
		Ramp identification		419 P/N 417 222 557	
		Calibration screw position		<i>no. 3</i>	
		Spring	260 lb - 420 lb	P/N 417 222 164	
		Clutch engagement	RPM	5200	
		Pin weight		18.8 grams	
		Lever		<i>std</i>	
	Driven pulley	Spring	Color	White	
			Preload	kg (lb)	
		Cam	Angle	48°-44°	
	Drive belt		Part number	P/N 486 130 047	
Calibration done at temperature of 20°C					
① The maximum horsepower RPM is applicable on the vehicle. It may be different under certain circumstances and BOMBARDIER INC. reserves the right to modify it without obligation.					

- A) Ski Spring = 17.5 N/mm (100 lbs/in) P/N 414 956 300 - 15 mm (.59 in) preload shock length = 360 mm (14.17 in)
- B) Center Spring = *std* 76 mm (3 in) travel max. for center arm
- C) Rear Spring = 12 mm (.47 in) 140° 3rd position: 486 099 100 right
486 099 300 left
- D) 102 mm (4 in) travel max. for rear arm
- E) Block ACM full couple

SECTION 08 - COMPETITION PREPARATION

Supplement for model: REV 800 2003

MODEL: REV 800 2003					
RACING TYPE		-GRASS DRAGS-			
	Maximum horsepower *	Ⓢ RPM	7600-7700		
C A R B U R E T O R	Carburetor type				
			<i>PTO</i>	<i>CENTER</i>	
			<i>MAG</i>		
	Main jet	foam/paper type filters	390	390	
	Needle		<i>std</i>	<i>std</i>	
	Needle clip position		4°	4°	
	Slide cut-away		<i>std</i>	<i>std</i>	
	Pilot jet		30	30	
	Needle jet				
	Pilot screw adjustment	± 1/8 turn	1.0	1.0	
	Needle valve		<i>std</i>	<i>std</i>	
Fuel		<i>minimum 100 octane</i>			
D R I V E R A T I O	Drive ratio		23 teeth P/N 504 085 400		
	Chain		74 links <i>std</i> P/N 504 151 857		
	Drive pulley	Type of drive pulley	TRA III		
		Ramp identification	419 P/N 417 222 557		
		Calibration screw position	<i>no. 4</i>		
		Spring	185 lb - 410 lb	P/N 415 019 500	
	Clutch engagement	RPM	4700		
		Pin weight	18.8 grams		
		Lever	<i>std</i>		
	Driven pulley	Spring	Color	Green	P/N 486 130 046
			Preload	kg (lb)	6° position
		Cam	Angle	50°-47°	P/N 417 126 580
	Drive belt		Part number	P/N 486 130 047	
Calibration done at temperature of 20°C					
Ⓢ The maximum horsepower RPM is applicable on the vehicle. It may be different under certain circumstances and BOMBARDIER INC. reserves the right to modify it without obligation.					

Ski Spring = 17.5 N/mm (100 lbs/in) P/N 414 956 300 - 15 mm (.59 in) preload shock length = 360 mm (14.17 in)

B) Center Spring = *std* 76 mm (3 in) travel max. for center arm

C) Rear Spring = 12 mm (.47 in) 140° 3rd position: 486 099 100 right
486 099 300 left

D) 102 mm (4 in) travel max. for rear arm

E) Block ACM full couple

SECTION 08 - COMPETITION PREPARATION

Supplement for model: SUMMIT 800 2003

MODEL: SUMMIT 800 2003					
RACING TYPE		-GRASS DRAGS-			
	Maximum horsepower *	Ⓢ RPM	7500-7600		
C A R B U R E T O R	Carburetor type				
			<i>PTO</i>	<i>CENTER</i>	
	Main jet	foam/paper type filters	370	370	
	Needle		<i>std</i>	<i>std</i>	
	Needle clip position	2 nylon washers under needle circlip			
	Slide cut-away		<i>std</i>	<i>std</i>	
	Pilot jet		35	35	
	Needle jet				
	Pilot screw adjustment	± 1/8 turn	1.5	1.5	
	Needle valve		<i>std</i>	<i>std</i>	
Fuel	minimum 110 octane				
D R I V E R A T I O	Drive ratio	23= P/N 504 085 400	43= std	23 teeth P/N 504 085 400	
	Chain	74 links <i>std</i> P/N 504 151 857			
	Drive pulley	Type of drive pulley	TRA III		
		Ramp identification	419 P/N 417 222 557		
		Calibration screw position	no. 3		
		Spring	185 lb - 410 lb	P/N 415 019 500	
	Clutch engagement	RPM	4700		
		Pin weight	18.8 grams		
		Lever	<i>std</i>		
	Driven pulley	Spring	Color	Green	P/N 486 130 046
		Preload	kg (lb)	6° position	
Cam		Angle	50°-44°	P/N 417 126 559	
Drive belt		Part number	P/N 486 130 047		
Calibration done at temperature of 20°C					
Ⓢ The maximum horsepower RPM is applicable on the vehicle. It may be different under certain circumstances and BOMBARDIER INC. reserves the right to modify it without obligation.					

- A) Ski Spring = 26.3 N/mm (150 lbs/in) P/N 415 020 900 - 5 mm (.20 in) preload shock length = 335 mm (13.19 in)
- B) Center Spring = *std* 76 mm (3 in) travel max. for center arm
- C) Rear Spring = 12 mm (.47 in) 140° 3rd position: 486 099 100 right
486 099 300 left
- D) 102 mm (4 in) travel max. for rear arm
- E) Block ACM full couple

SECTION 08 - COMPETITION PREPARATION

OPTIONAL RACE TRACKS

STOCK CLASS ONLY

Snocross/Cross Country

MODEL	STOCK TRACK P/N	SKI-DOO OPT.	CAMOPLAST OPT.	KIMPEX OPT.
03 MX Zx 440 REV	504 152 200	504 151 841	690-9892	04-749-150 RC
03 MX Z 500	504 212 600	504 151 815	690-9892	04-749-150 RC
03 MX Z 600 REV	504 152 157	504 151 815	690-9892	04-749-150 RC
03 MX Z 700	504 212 600	504 151 815	690-9892	04-749-150 RC
03 MX Z 800 REV	504 152 157	504 151 815	690-9892	04-749-150 RC
02 MX Zx 440 LC	504 152 102	504 151 815	690-9855	04-748-125 RC

Drag

All Models	All Models	N/A	700-9811	N/A
------------	------------	-----	----------	-----

Oval Sprint

All Models	All Models	N/A	700-9844	N/A
------------	------------	-----	----------	-----

Enduro

All Models	All Models	N/A	700-9811	N/A
------------	------------	-----	----------	-----

Hill Climb

All Models	Any track offered by Bombardier without modifications to chassis			
------------	--	--	--	--

TABLE OF CONTENTS

SERVICE TOOLS	09-2
ENGINE	09-2
TRANSMISSION	09-6
SUSPENSION	09-10
VEHICLE	09-13
NEW TOOLS AND USAGE	09-15

SERVICE TOOLS

ENGINE

Hose pincher (2)
(P/N 295 000 076)

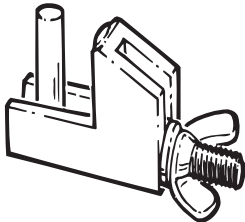

A01B2I4

APPLICATION
All vehicles.

NOTE: Only the P/N has been changed. This hose pincher is identical to the P/N 529 009 900.

Magneto puller ring
(P/N 420 876 080)

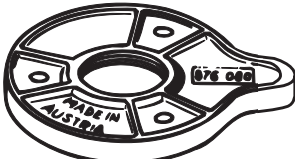

A00C1R4

APPLICATION
All engines except 247.

Magneto puller
(P/N 529 035 547)

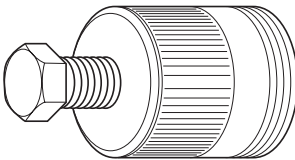

A00C1A4

APPLICATION
All engines except 247.

NOTE: The previous extractor (P/N 529 022 500) can be upgraded by replacing the screw with the new one (P/N 529 035 549).

Engine leak tester kit
(P/N 861 749 100)

1) Hand pump
(P/N 529 021 800)

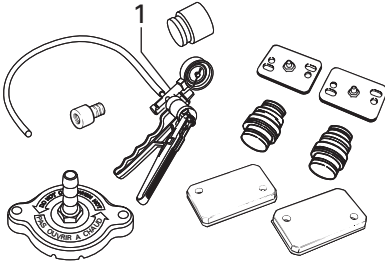

A01B5F5

APPLICATION
All engines.

Piston circlip installer
(P/N 529 035 686) 20 mm

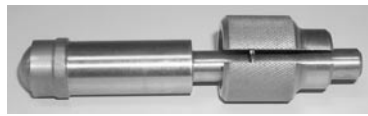

A32B0C4

APPLICATION
Engines with tab type circlip.

1) Piston pin puller
(P/N 529 035 503)

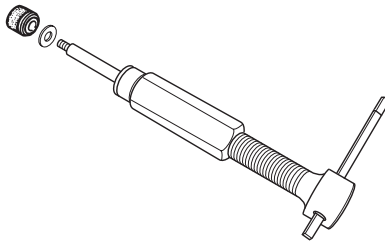

A02B094

2) Sleeve kit 18 mm
(P/N 529 035 541)

3) Sleeve kit 20 mm
(P/N 529 035 542)

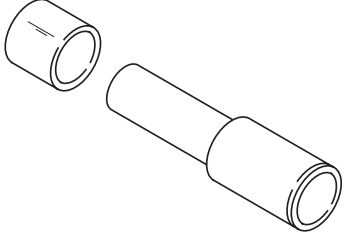

A01B5A4

NOTE: 18 mm sleeve kit contains 1 shouldered sleeve and 3 sleeves. 20 mm sleeve kit contains 1 shouldered sleeve and 2 sleeves.

APPLICATION

- 1) All engines.
- 2) 277, 443, 503 and 809 engine.
- 3) 593, 670 and 693 engines.

NOTE: The previous piston pin puller (P/N 529 029 000) can be upgraded by adding protector (P/N 529 035 513) and replacing the expansion sleeve with appropriate sleeve kit.

ENGINE (continued)

Rubber pad
(P/N 529 023 400)

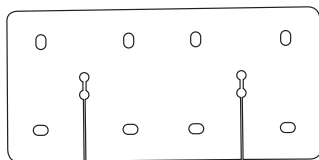

A01B4C4

APPLICATION
All cageless bearing engines.

Multimeter
(P/N 529 035 788)

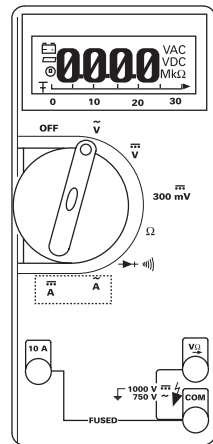

F01B104

APPLICATION
All models.

The following tools are highly recommended to optimize your basic tool kit and reduce repair time.

1-2) Crankshaft bearing puller with screw
(P/N 420 877 635)

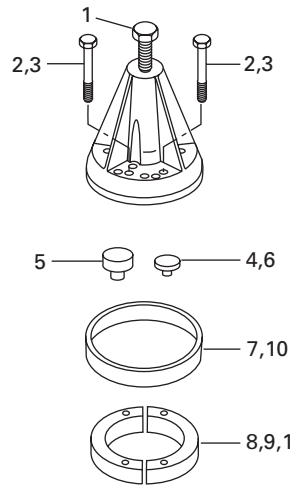

A01B547

APPLICATION
All engines.

1) Screw M16 x 1.5 x 150	(P/N 420 940 755)
2) Screw M8 x 40 (4)	(P/N 420 840 681)
3) Screw M8 x 70 (4)	(P/N 420 841 201)
4) Crankshaft protector 247 engine.	(P/N 420 976 890)
5) Crankshaft protector PTO All engines except 247.	(P/N 420 876 552)
6) Crankshaft protector MAG All engines except 247.	(P/N 420 876 557)
7) Puller ring Use with half rings (P/N 420 977 475 or 420 276 025).	(P/N 420 977 490)
8) Half ring (2) For 72 mm O.D. bearings.	(P/N 420 977 475)
9) Half ring (2) For 62 mm O.D. bearings.	(P/N 420 276 025)
10) Puller ring For half rings (P/N 420 977 479).	(P/N 420 977 494)
11) Half ring (2) For 80 mm O.D. bearings.	(P/N 420 977 479)

SECTION 09 - SERVICE TOOLS

ENGINE (continued)

Piston circlip installer

- A) (P/N 529 035 561) 18 mm
- B) (P/N 529 035 562) 20 mm



A00B4Y4

APPLICATION

A) All engines except 593, 670, 693 and 793.

NOTE: This tool replaces circlip installer (P/N 529 016 900).

B) 2001 and older 593, 670 and 693 engines.

NOTE: This tool replaces circlip installer (P/N 290 877 016).

Piston pin/connecting rod bearing centering tool (P/N 529 009 100)

NOTE: New diameter is 9.65 mm (0.380 in).

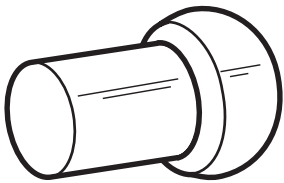

A01B1R4

APPLICATION

All engines except cageless and 670 engines.

Ring compressor

- A) (P/N 420 876 090) (62 mm)
- B) (P/N 420 876 974) (69.5 mm)
- C) (P/N 420 876 970) (72 mm)
- D) (P/N 420 876 972) (76 mm)
- E) (P/N 420 876 975) (67.5 mm)
- F) (P/N 529 030 800) (78 mm)

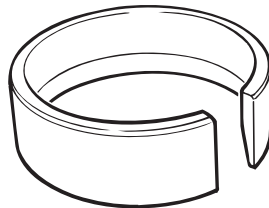

A01B1T4

APPLICATION

- A) 377 engine.
- B) 467 and 494 engines.
- C) 503, 253 and 536 engines.
- D) 582, 583 and 643 engines.
- E) 443 and 447 engines.
- F) 670 engine.

Cylinder aligning tool

- A) (P/N 420 876 904) (on exhaust side)
- B) (P/N 420 876 171) (on intake side)

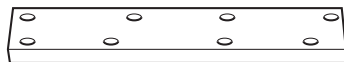

A00B084

APPLICATION

- A) 2-cylinder liquid cooled engines.
- B) 2-cylinder fan cooled engines.

Driver tool

(P/N 529 035 521)



A00B4O4

APPLICATION

Mini Z.

Attachment

(P/N 529 035 522)

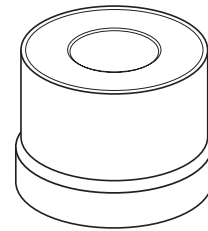

A00B4P4

APPLICATION

Mini Z.

Pilot 22 mm

(P/N 529 035 523)

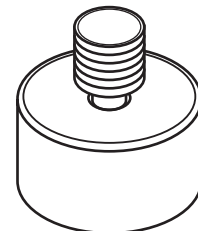

A00B4Q4

APPLICATION

Mini Z.

ENGINE (continued)

Carburetor tool kit
(P/N 404 112 000)

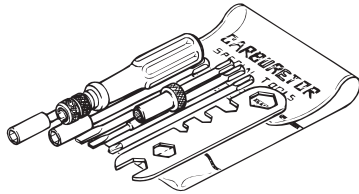

A00B2F4

APPLICATION
All models.

Stroboscopic timing light
(P/N 529 031 900)



A00B4F4

APPLICATION
All engines.

Injection pump gear holder
(P/N 420 277 905)

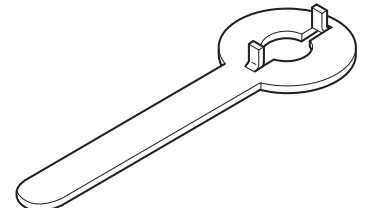

A00C164

APPLICATION
All liquid cooled engines.

Float level gauge
(P/N 529 035 520)

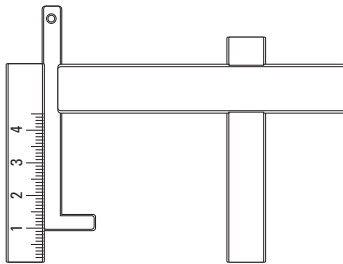

A00B4N4

APPLICATION
All models.

RAVE movement indicator
(P/N 861 725 800)

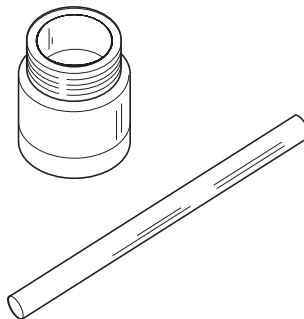

A18B014

APPLICATION
All RAVE equipped engines.

Digital/induction type tachometer
(P/N 529 014 500)

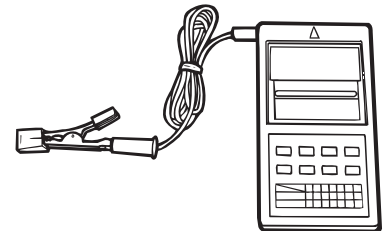

F01B1G4

APPLICATION
All engines.

Circuit tester
(continuity light)
(P/N 414 012 200)

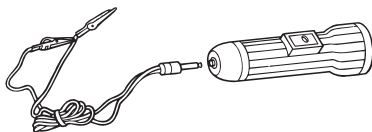

A00C214

APPLICATION
All vehicles.

Dial indicator
(TDC gauge)
(P/N 414 104 700)

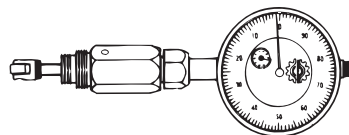

A00B4E4

APPLICATION
All engines.

Exhaust spring installer/remover
(P/N 529 035 559)

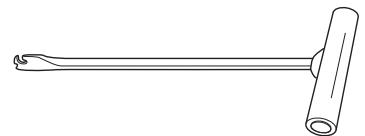

A00C3S4

APPLICATION
All models.

SECTION 09 - SERVICE TOOLS

ENGINE (continued)

Large hose pincher
(P/N 529 032 500)
(TYPICAL)

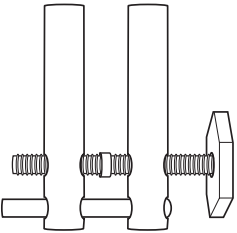

F01B234

APPLICATION
All vehicles.

NEW

A-arms nut wrench
(P/N 529 035 876)



A33B054

APPLICATION
REV.

NEW

Spark plug lift ring
(P/N 529 035 876)



A33B064

APPLICATION
REV.

TRANSMISSION

Driven pulley opening tool
(P/N 529 017 200)

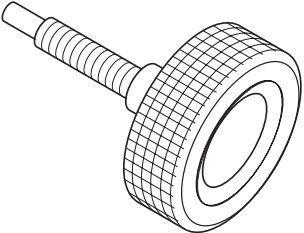

A00A1A4

APPLICATION
All non-RER models.

TRA drive pulley puller
(P/N 529 022 400)

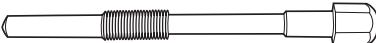

A06B014

APPLICATION
TRA drive pulley for the 454, 494, 599, 670, 699, 779 and 809 engines.

Forks (3)
(P/N 529 005 500)

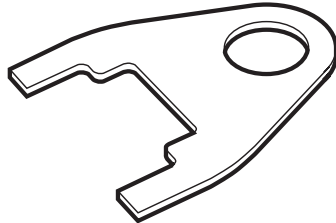

A16B014

APPLICATION
All vehicles equipped with a TRA drive pulley.

TRA drive pulley puller
(P/N 529 007 900) (25 mm)

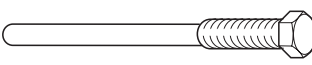

A18B044

APPLICATION
TRA drive pulley for 443, 467, 503, 536 and 537 engines.

Clutch holder
(P/N 529 006 400)



A01B154

APPLICATION
All TRA drive pulleys.

Transmission alignment bar



A01B4D4

APPLICATION
F-Series, S-Series and ZX series with TRA.

TRANSMISSION (continued)

Drive belt tension adjuster tool
(P/N 529 008 700)

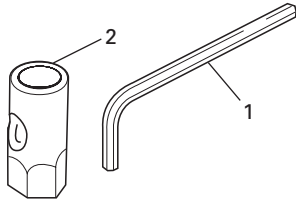

A15B044

Parts included:

- 1) Hexagonal wrench
(P/N 420 876 730).
- 2) Socket wrench
(P/N 529 015 000).

APPLICATION

All vehicles except Élan, Tundra II and Skandic WT.

Driven pulley spring compressor
(P/N 529 035 300)

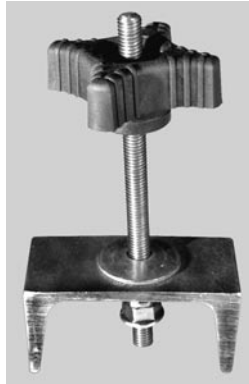

A05B034

APPLICATION

Tundra R.

Countershaft bearing
remover/installer
(P/N 529 035 699)

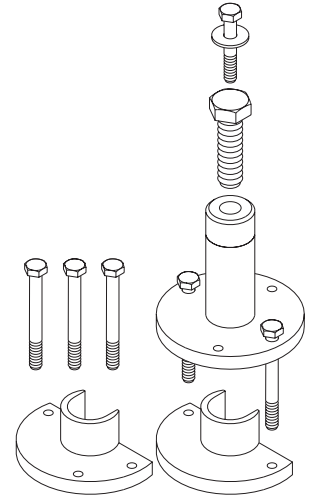

A00B5K4

APPLICATION

ZX and CK3 Series.

NOTE: This tool replaces CK3 series countershaft bearing remover/installer (P/N 529 035 554).

Pulley spring compressor
(P/N 529 035 524)

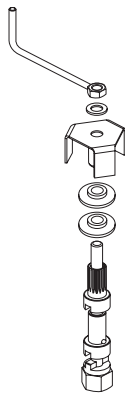

A02D1P4

APPLICATION

All models.

NOTE: This tool has Acme threads and replaces spring compressor (P/N 529 018 600).

Tension tester
(P/N 414 348 200)



A00C074

APPLICATION

All models.

SECTION 09 - SERVICE TOOLS

TRANSMISSION (continued)

The following tools are highly recommended to optimize your basic tool kit and reduce repair time.

Driven pulley opening tool
(P/N 529 035 501)



A03D2P4

APPLICATION

S and CK3 series with RER.

NOTE: This tool replaces driven pulley opening tool (P/N 529 019 500).

Large bushing extractor
(P/N 529 035 576)

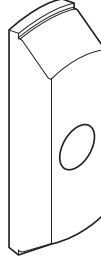

A02D1Q4

APPLICATION

Formula type driven pulley.

NOTE: Use this tool only with new puller (P/N 529 035 524) that has Acme threads and support plate included with extractor (P/N 529 031 100).

Chaincase seal pusher
(P/N 529 035 584)

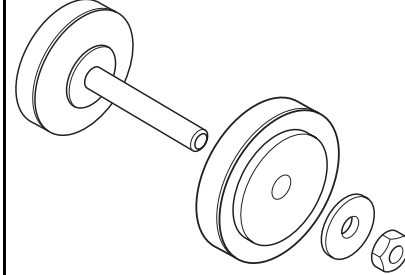

A00B504

APPLICATION

S, F, CK3 and ZX series.

NOTE: This tool replaces chaincase upper seal pusher (P/N 529 032 300).

Bushing extractor/installer
(P/N 529 031 300)



A01B5G4

APPLICATION

TRA drive pulley spring cover with replaceable bushing

Large bushing extractor
(P/N 529 035 575)

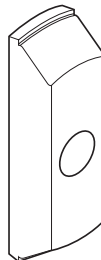

A02D1Q4

APPLICATION

LPV 27 driven pulley.

NOTE: Use this tool only with new puller (P/N 529 035 524) that has Acme threads and support plate included with extractor (P/N 529 031 100).

TRA drive pulley puller (27 mm)
(P/N 529 010 100)

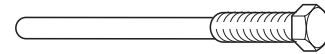

A18B044

APPLICATION

TRA drive pulley (27 mm) shaft except 454, 670 and 779 engines.

TRANSMISSION (continued)

Drive axle sprocket adjuster
(P/N 861 725 700)

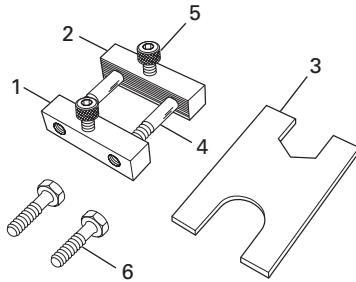

A01B204

Parts included in the kit:

- 1) Block with threads
(P/N 529 010 700)
- 2) Block without threads
(P/N 529 010 800)
- 3) Plate
(P/N 529 010 600)
- 4) Bolt M10 (2)
(P/N 222 007 565)
- 5) Allen screw M8 (2)
(P/N 222 983 065)
- 6) Screw M8 (2)
(P/N 222 082 565)

NOTE: When the tool is to be used between tunnel and sprocket use screws M8.

APPLICATION

All vehicles except Élan.



Clutch alignment bar
(P/N 529 035 831)

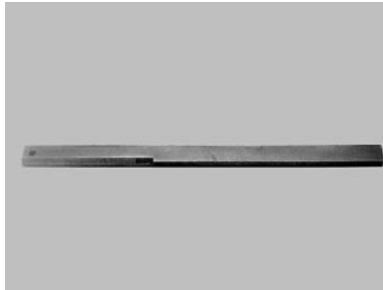

A33B034

APPLICATION

REV.

SECTION 09 - SERVICE TOOLS

SUSPENSION

Shock spring removal kit
(P/N 529 035 504)
Replacement clevis pin:
(P/N 414 528 400)

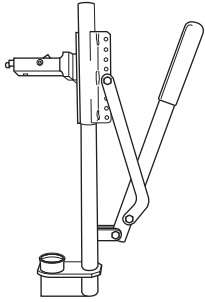

A01B404

APPLICATION

All suspensions with coil spring.

NOTE: The previous shock spring removal kit (P/N 529 027 100) can be upgraded by replacing the stopper with a wider stopper (P/N 529 035 551).

Track cleat remover
(P/N 529 028 700)

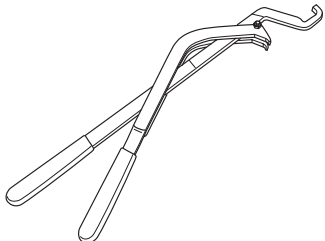

A01F224

APPLICATION

1994 and newer except Élan and Tundra II.

Camber angle tool
(P/N 529 021 600)

NOTE: Angle finder with a magnetic base must be used.

Suggestion: K-D tool no. 2968

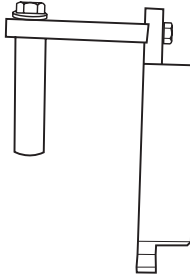

A06B024

APPLICATION

All DSA front suspensions.

Track tension gauge
(P/N 529 021 500)

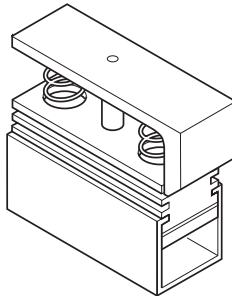

A00B3X4

APPLICATION

All models except Élan.

Track cleat installer
(P/N 529 028 800)

Narrow

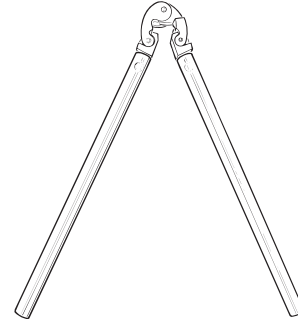

A01B1M4

APPLICATION

1994 and newer.

Dome guide

A) (P/N 529 026 500)

B) (P/N 529 035 728)



A06F1B4

APPLICATION

A) C-36 T/A shocks.

B) C-46 T/A shocks.

SUSPENSION (continued)

Shock wrench
(P/N 529 035 727)



A00F224

All T/A shocks except 2003
MX Zx 440.

Gas shock valve tool
(tire valve type)
(P/N 529 035 570)

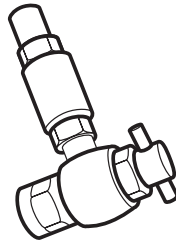

A02F134

APPLICATION
1999 and older T/A shocks and
some 2000 and up T/A shocks.

NEW
A-arms nut wrench
(P/N 529 035 876)



A33B024

APPLICATION
REV.

HPG shock holding tool
(P/N 529 035 769)



A01B5H4

All HPG shocks

Tool for shock (needle type)
(P/N 529 035 614)

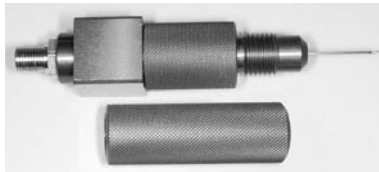

A00B5I4

APPLICATION
Most 2000 and up T/A shocks.

NEW
Ball joint remover
(P/N 529 035 877)

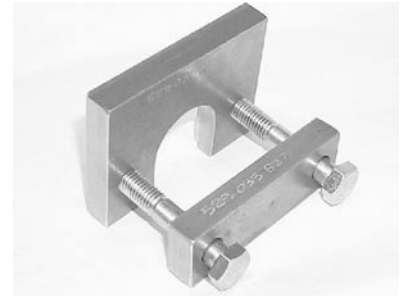

A33B074

APPLICATION
REV.

Piston guide
A) (P/N 529 026 600)
B) (P/N 529 035 608)

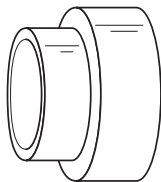

A06F1C4

APPLICATION
A) C-36 T/A shocks.
B) C-46 T/A shocks.

Adjustment wrench
(P/N 520 000 126)



A00B5H4

APPLICATION
SC-10 (coupling blocks).

SECTION 09 - SERVICE TOOLS

SUSPENSION (continued)

NEW

Ball joint remover support
(P/N 529 035 873)



V00B1J4

APPLICATION
REV.

A cylindrical metal component with a slightly wider top rim and a narrower bottom section, used as a support for a ball joint remover.

NEW

Ball joint installer support
(P/N 529 035 875)



V00B1L4

APPLICATION
REV.

A simple cylindrical metal component used as a support for a ball joint installer.

NEW

Ball joint installer
(P/N 529 035 874)



V00B1K4

APPLICATION
REV.

A cylindrical metal component with a slightly wider top rim, used as a ball joint installer.

VEHICLE

Protective mat
(P/N 529 030 600)



A01B45W

APPLICATION

All vehicles.

Dolly
(P/N 529 029 900)

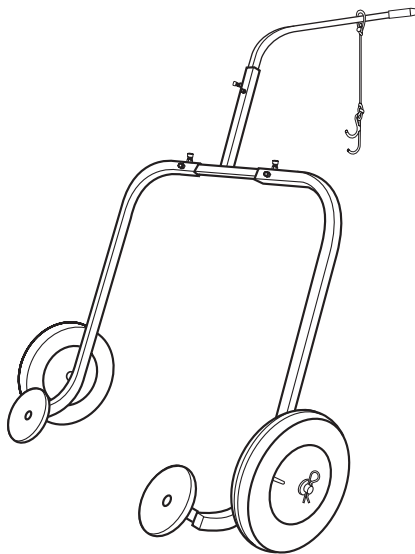

A00B4CJ

APPLICATION

All models.

Snowmobile jack
(P/N 529 020 000)

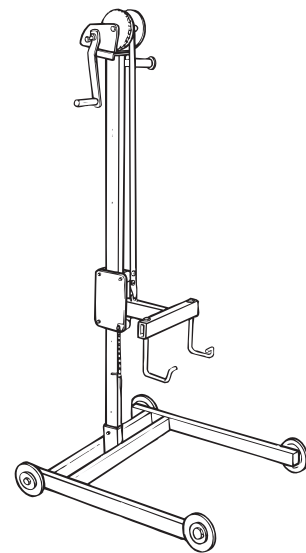

A01A1JJ

APPLICATION

All models.

SECTION 09 - SERVICE TOOLS

VEHICLES (continued)

Adjustment wrench
(P/N 529 035 603)



A32B044

APPLICATION

To remove and install fuel tank nut on ZX series.

NEW

Filler neck nut wrench
(P/N 529 035 891)









A33B084

APPLICATION

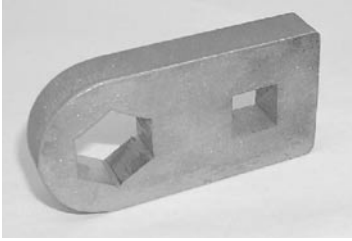
REV.

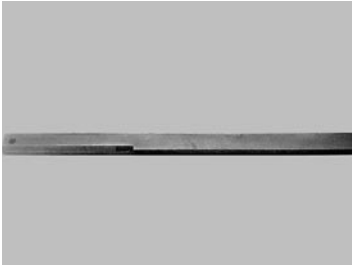
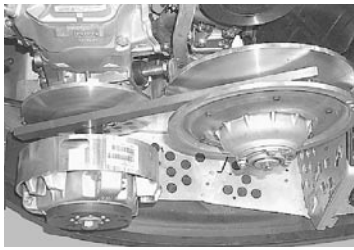
SECTION 09 - SERVICE TOOLS

NEW TOOLS AND USAGE

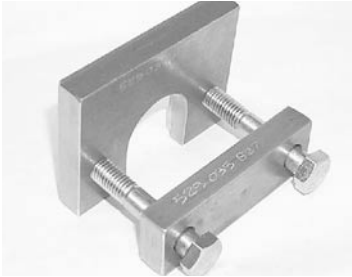
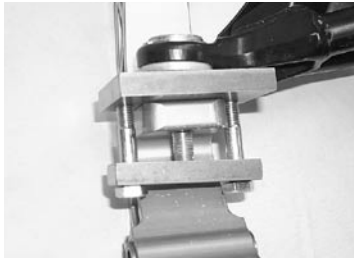
NEW TOOLS	USAGE	DESCRIPTION	P/N	MODEL
		A-arms nut wrench (SUSPENSION)	529 035 876	REV
		Clutch alignment bar (TRANSMISSION)	529 035 831	REV
		Engine removal hook (use with 529 035 830) (ENGINE)	529 035 829	REV
		Spark plug lift ring (ENGINE)	529 035 830	REV
		Ball joint remover (SUSPENSION)	529 035 827	REV

SECTION 09 - SERVICE TOOLS

NEW TOOLS	USAGE	DESCRIPTION	P/N	MODEL
		Ball joint remover support (SUSPENSION)	529 035 873	REV
		Ball joint installer (SUSPENSION)	529 035 874	REV
		Ball joint installer support (SUSPENSION)	529 035 875	REV
		Filler neck nut wrench (VEHICLE)	529 035 891	REV



™® ARE TRADEMARKS AND ® ARE REGISTERED TRADEMARKS OF BOMBARDIER INC. OR ITS SUBSIDIARIES.

© 2002 BOMBARDIER INC. ALL RIGHTS RESERVED.

PRINTED IN CANADA

™® SONT DES MARQUES DE COMMERCE ET ® SONT DES MARQUES DÉPOSÉES DE BOMBARDIER INC. OU SES FILIALES.

© 2002 BOMBARDIER INC. TOUS DROITS RÉSERVÉS.

IMPRIMÉ AU CANADA

