

# 2018 SPARK

LINE TYPE	LEGEND
55 / 60 VOLTS	WH = WHITE BK = BLACK
12 VOLTS SWITCHED	RD = RED YE = YELLOW
12 VOLTS UNSWITCHED	VT = VIOLET BG = BEIGE (TAN)
5 OR 3.3 VOLTS	GN = GREEN BN = BROWN
DIGITAL SIGNAL	GY = GREY BU = BLUE
AC VOLTAGE	PK = PINK OG = ORANGE
POWER CONTROL	
ANALOG SIGNAL	
COMMUNICATION	⊗ : JUNCTION POSITION (JT)
A-D GROUND	— : CAN HI WIRE
POWER GROUND	- - - : CAN LO WIRE

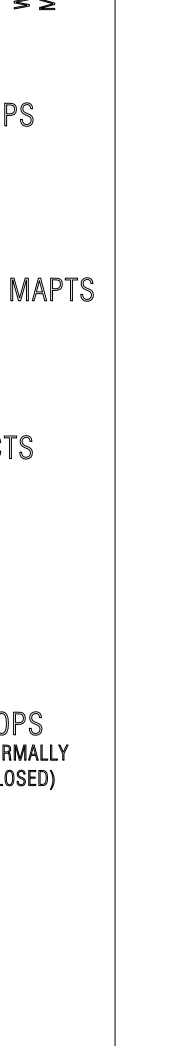
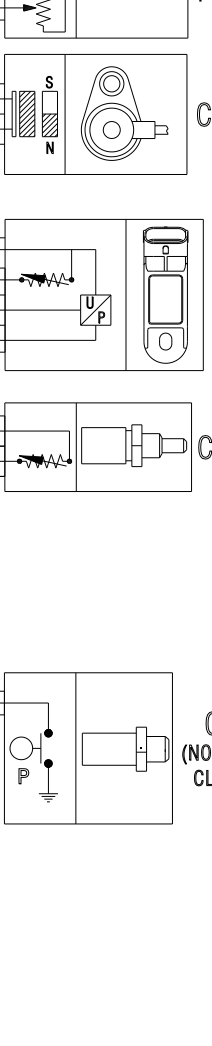
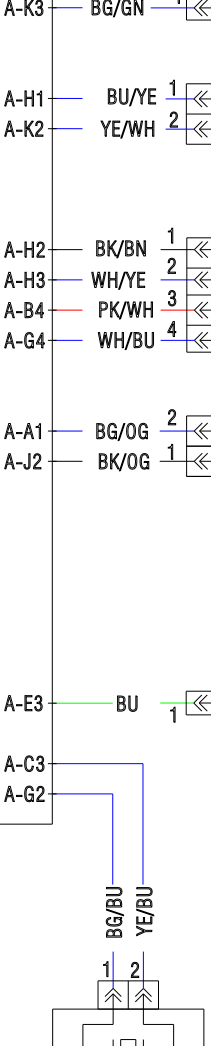
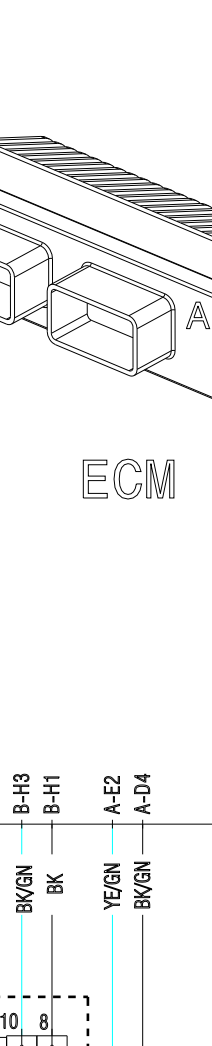
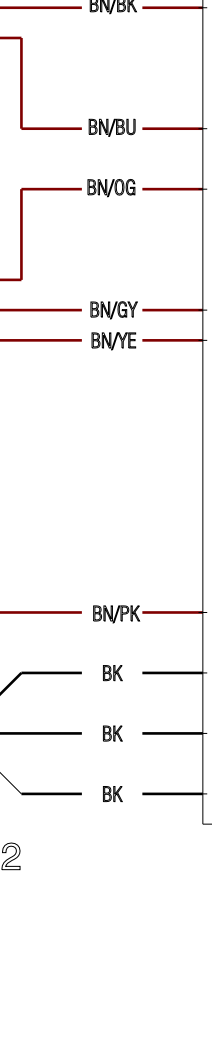
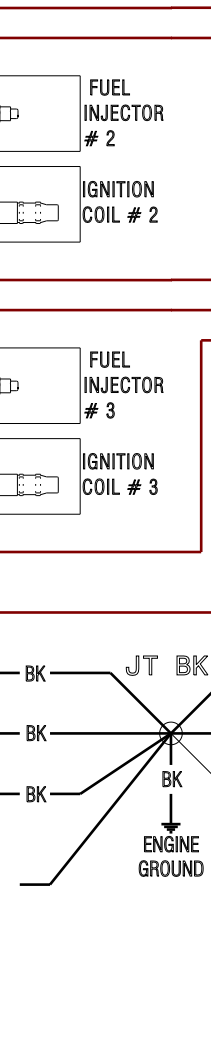
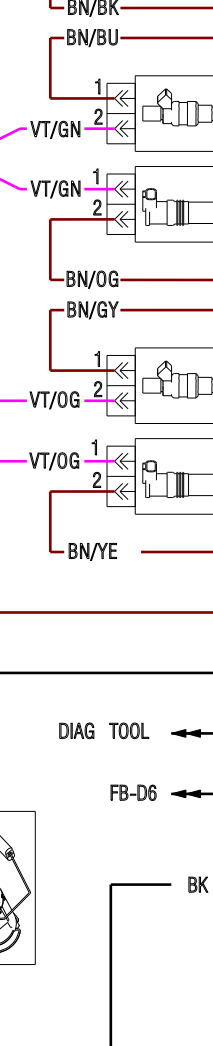
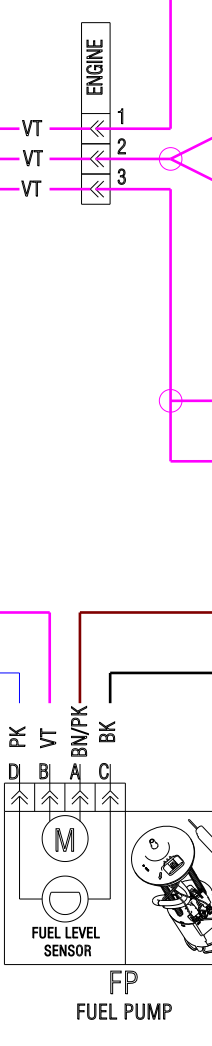
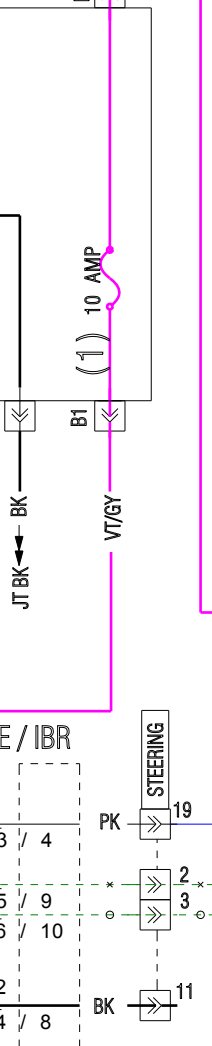
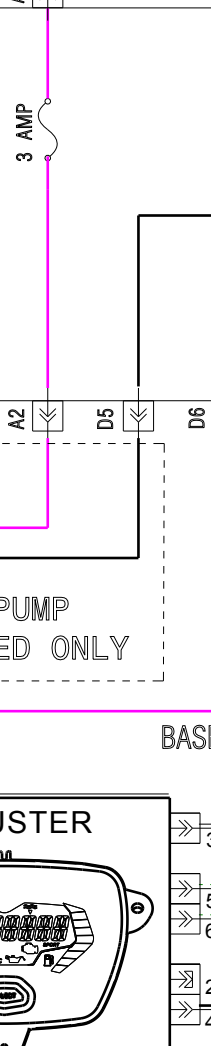
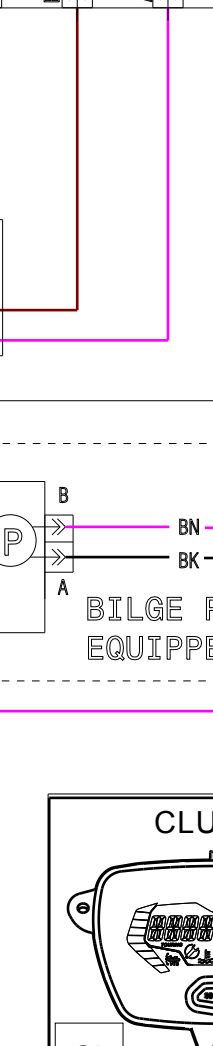
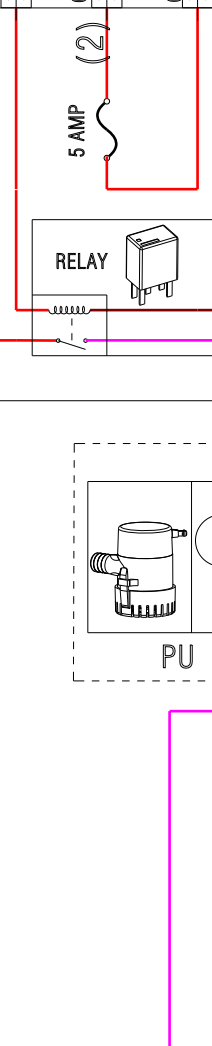
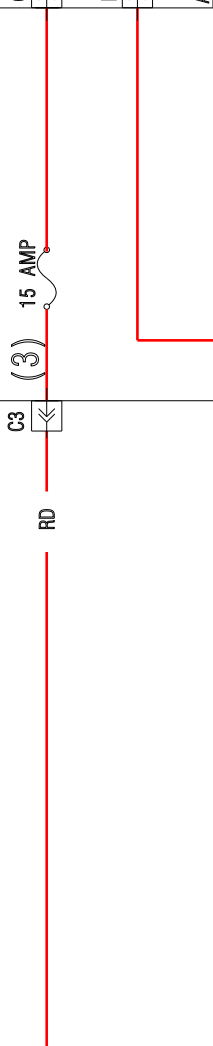
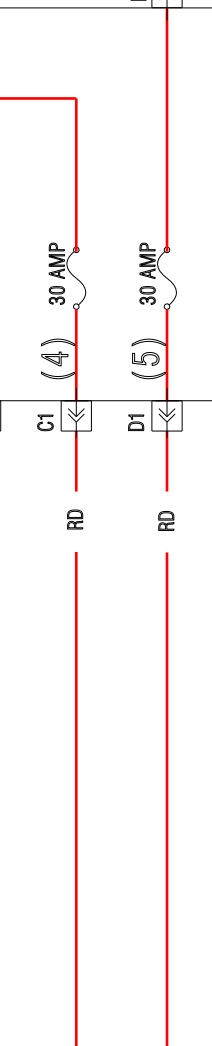
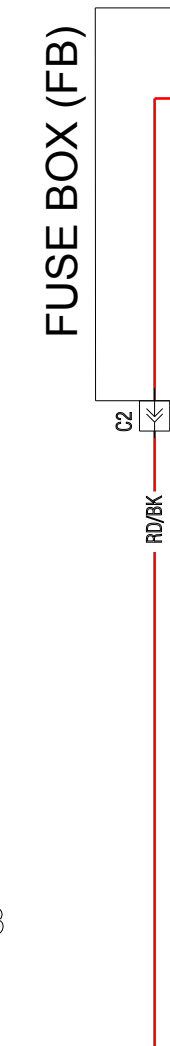
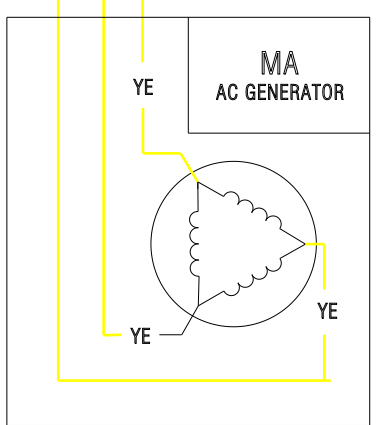
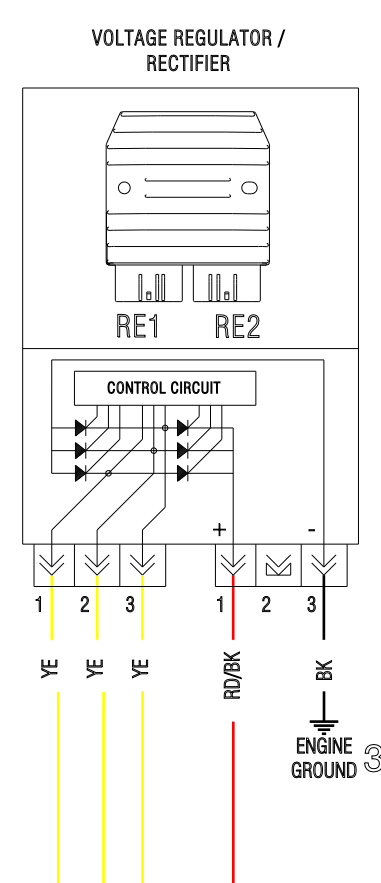
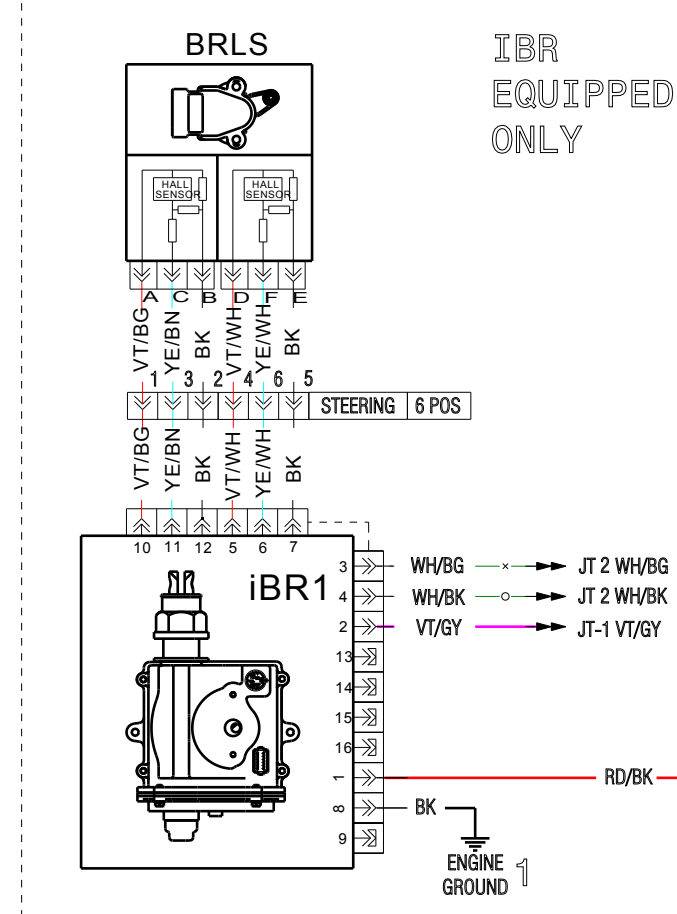
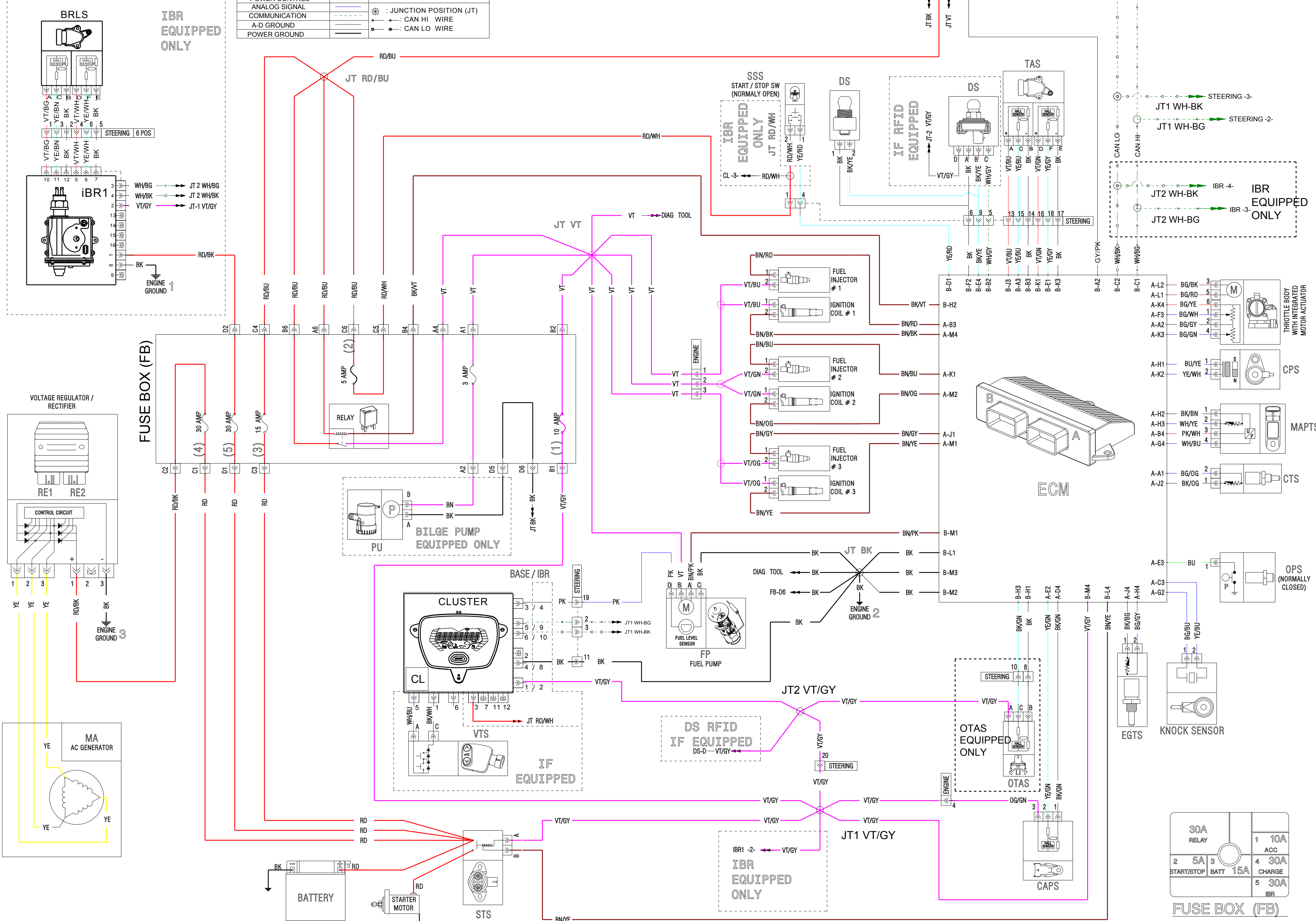

30A RELAY	1 10A ACC
2 5A START/STOP	3 15A BATT
4 30A CHARGE	5 30A IBR

**FUSE BOX (FB)**



# 2018 GTI / GTR / WAKE (130,155,230)

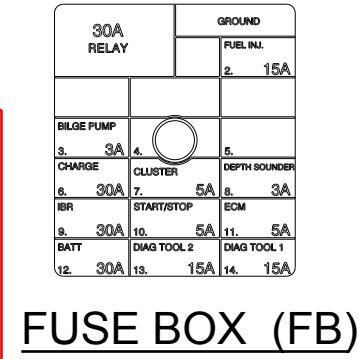
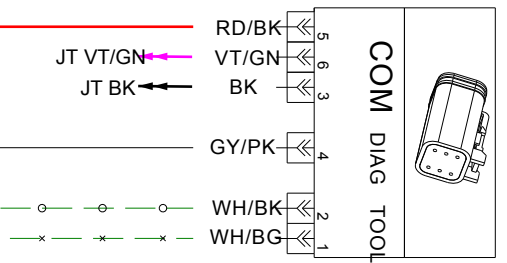
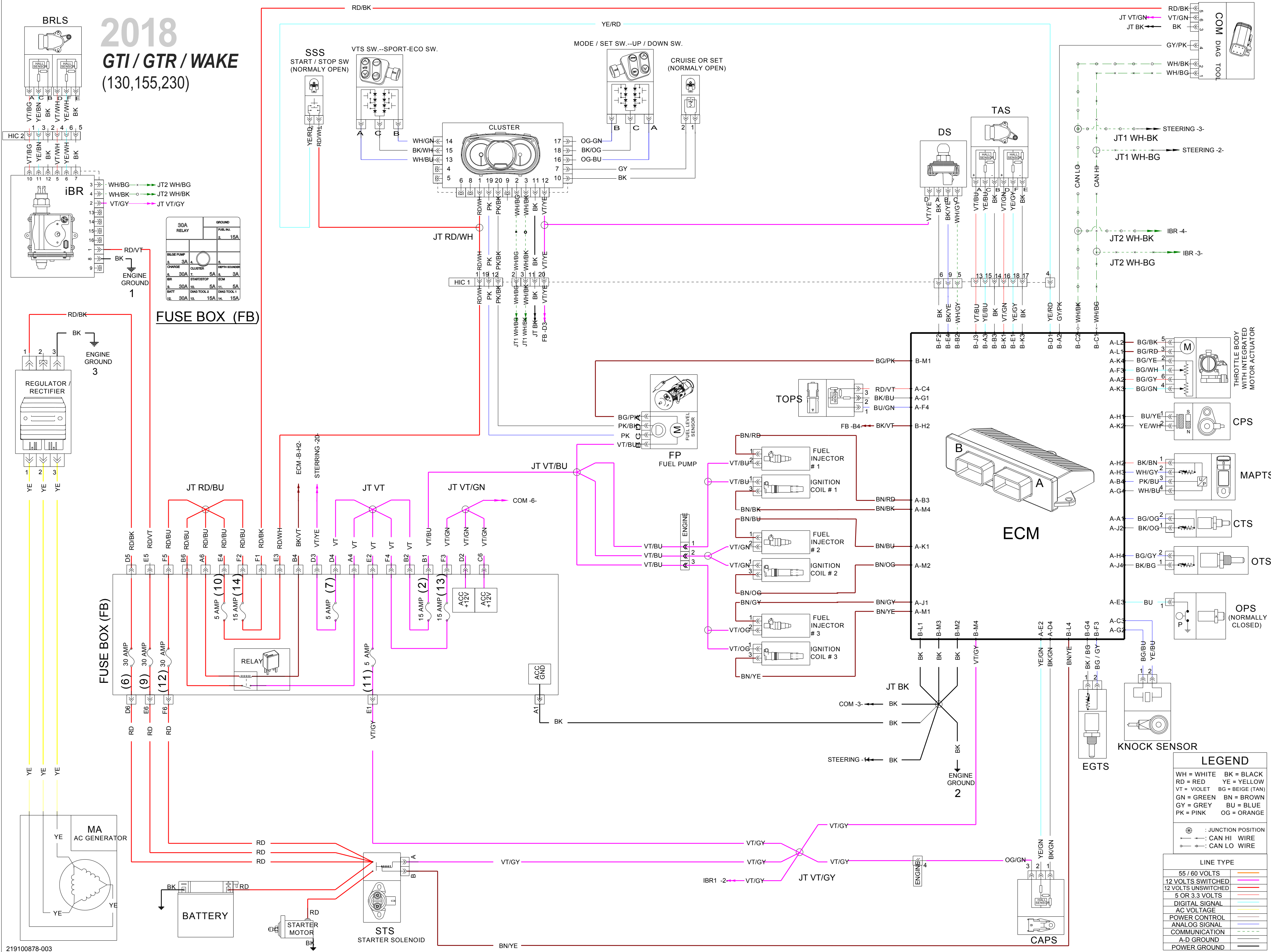

**LEGEND**

WH = WHITE	BK = BLACK
RD = RED	YE = YELLOW
VT = VIOLET	BG = BEIGE (TAN)
GN = GREEN	BN = BROWN
GY = GREY	BU = BLUE
PK = PINK	OG = ORANGE

**LINE TYPE**

- 55 / 60 VOLTS
- 12 VOLTS SWITCHED
- 12 VOLTS UNSWITCHED
- 5 OR 3.3 VOLTS
- DIGITAL SIGNAL
- AC VOLTAGE
- POWER CONTROL
- ANALOG SIGNAL
- COMMUNICATION
- A-D GROUND
- POWER GROUND

# 2018 GTX / RXT / WAKE PRO

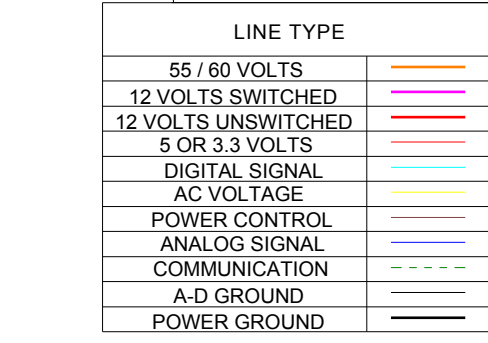
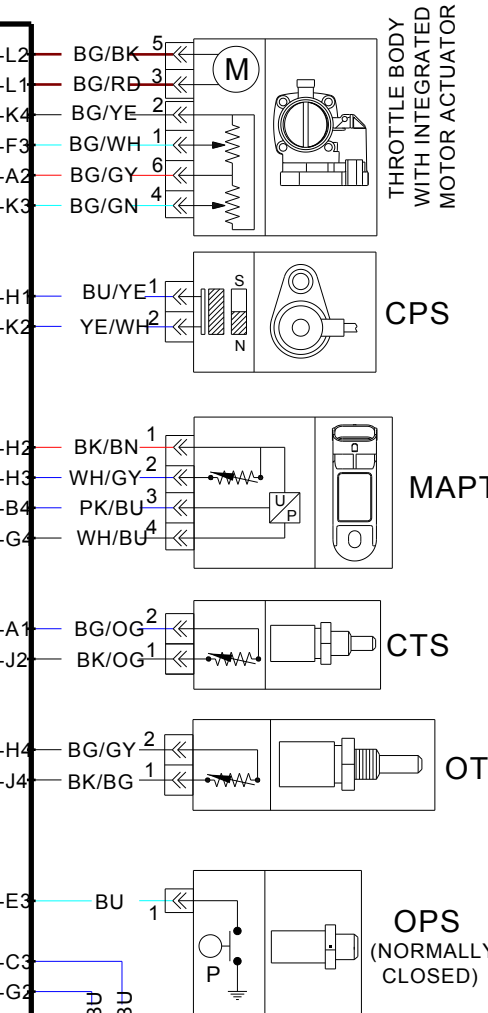
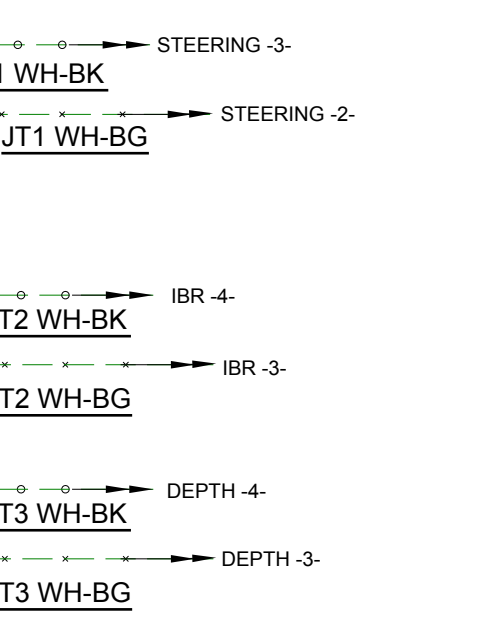
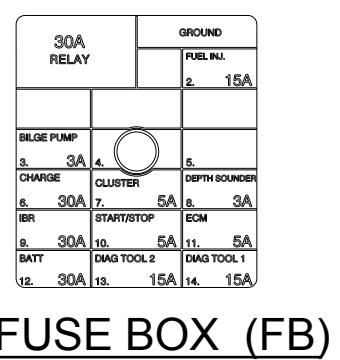
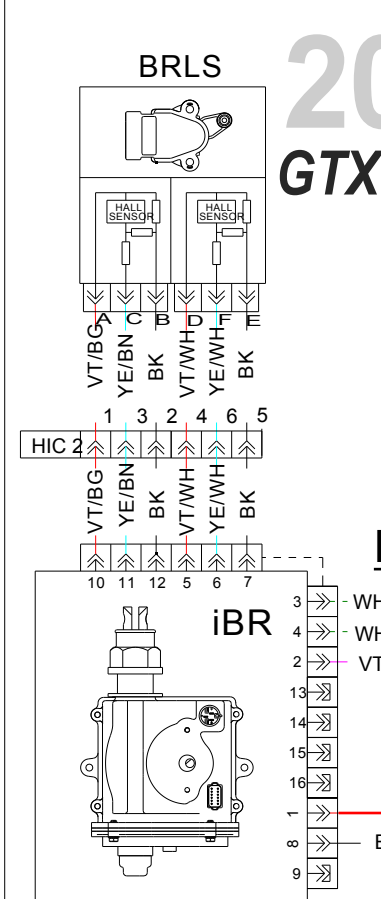
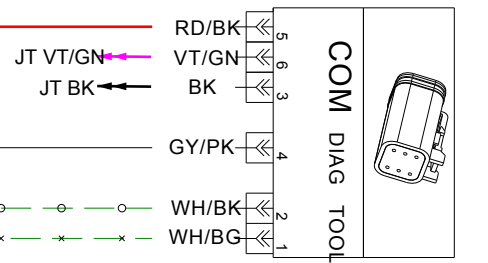
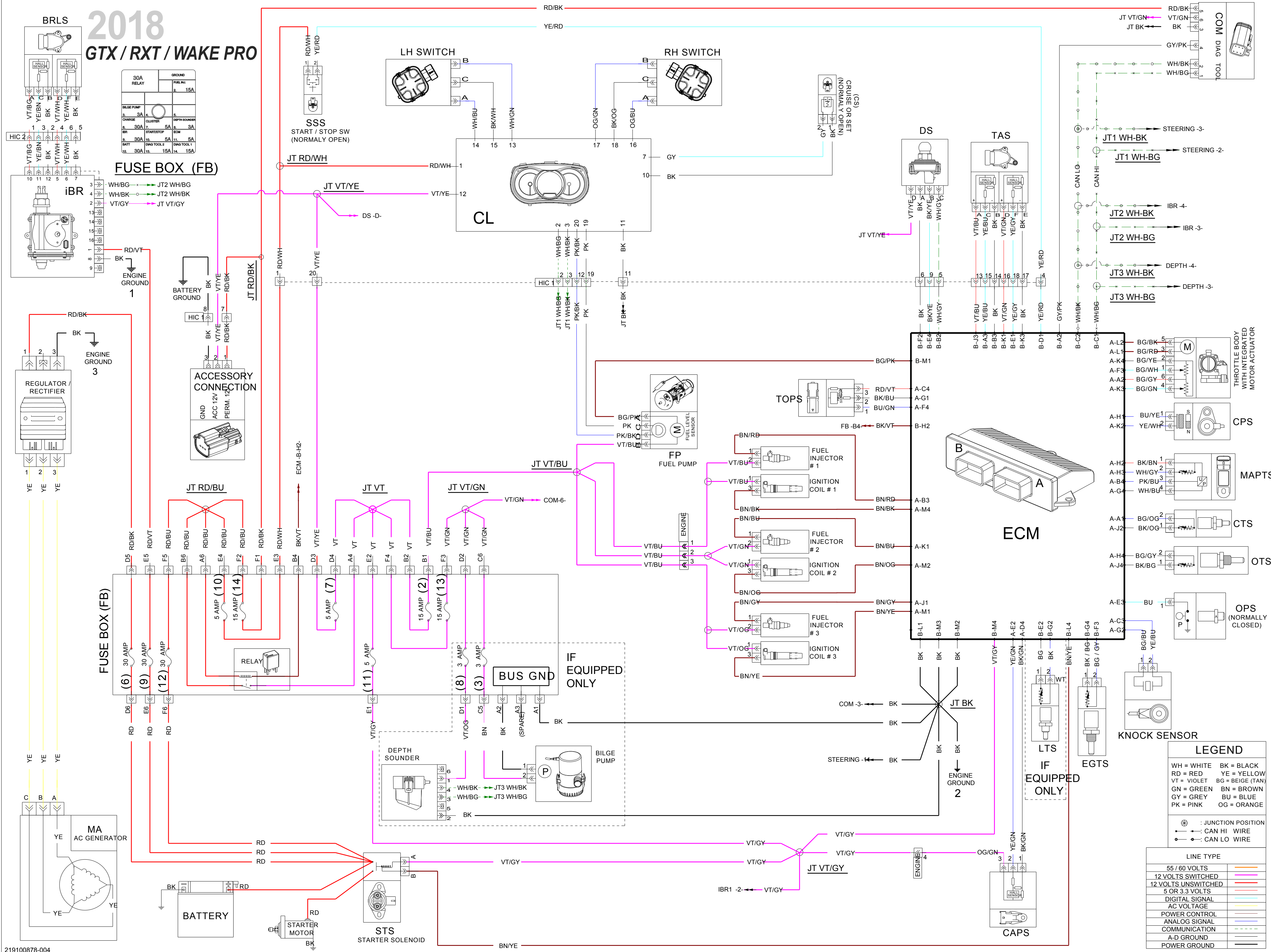

# 2018 RXP X

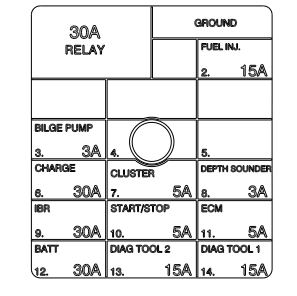
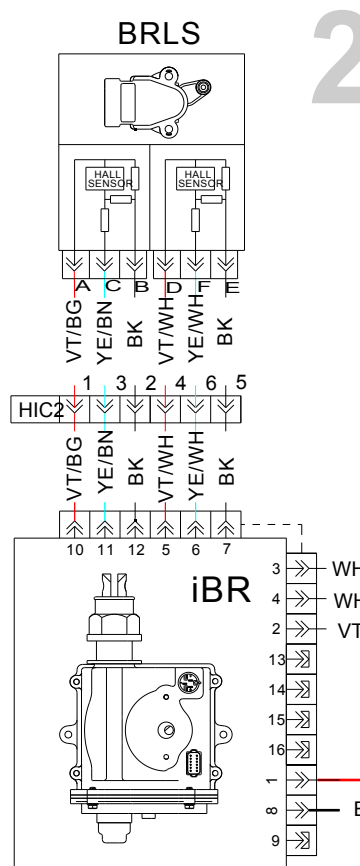
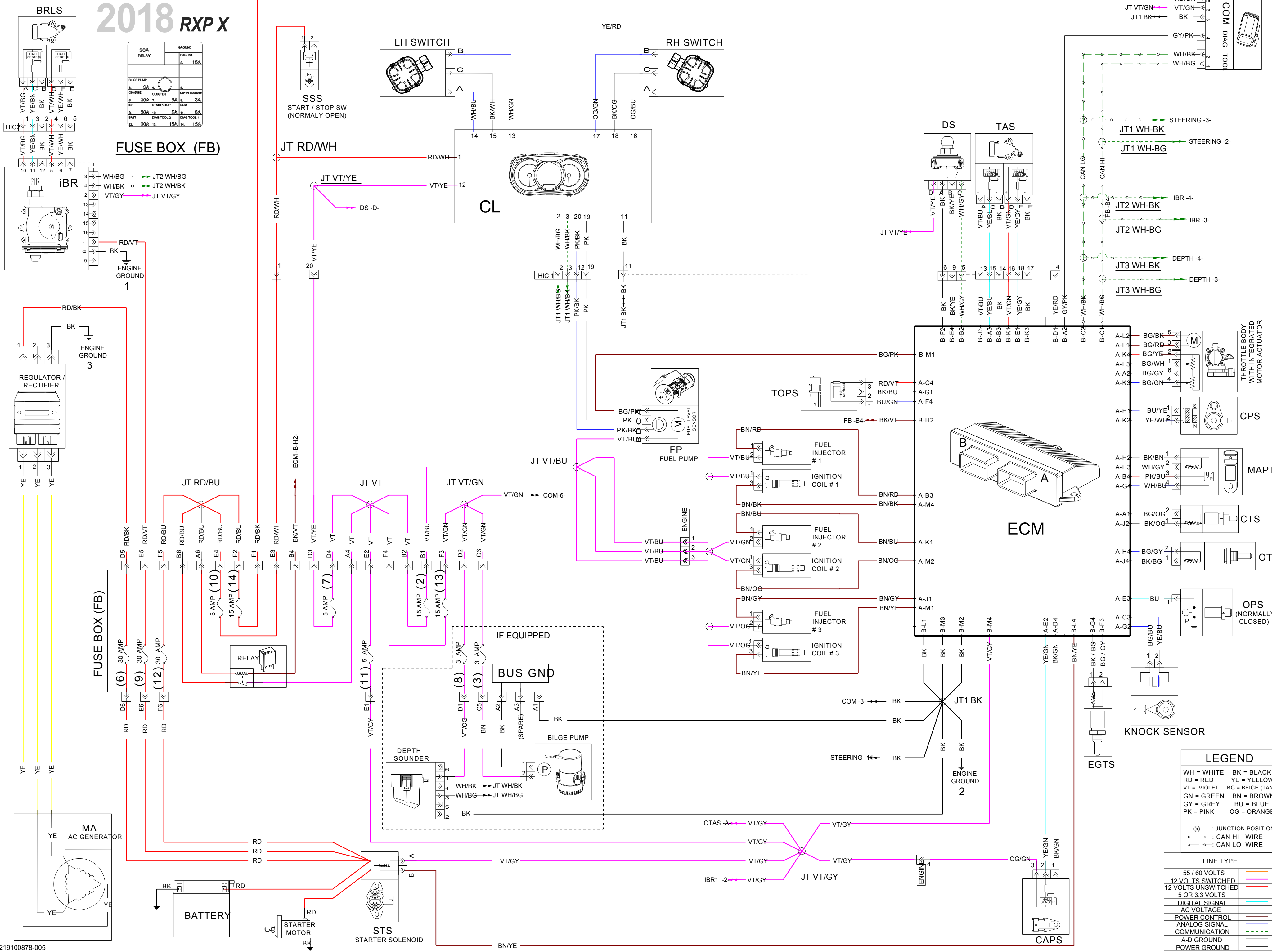

## FUSE BOX (FB)

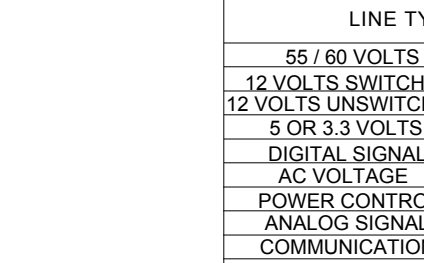
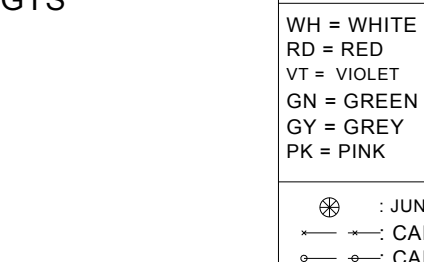
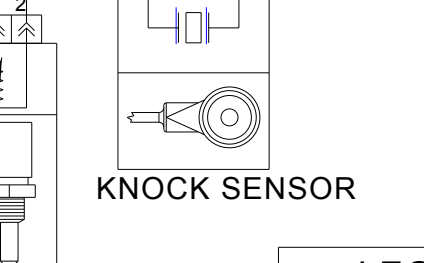
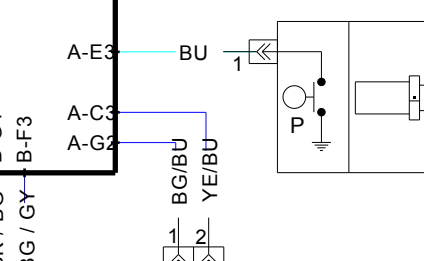
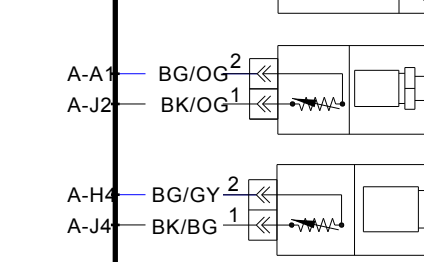
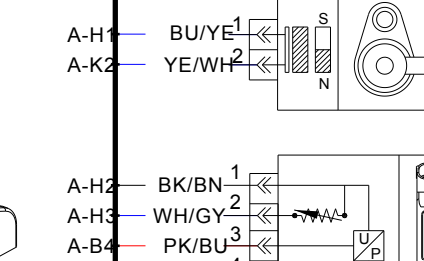
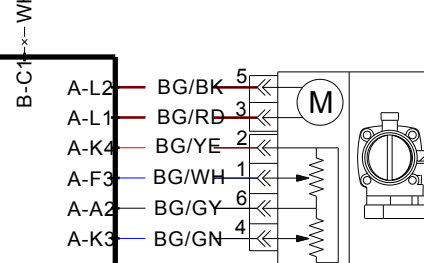
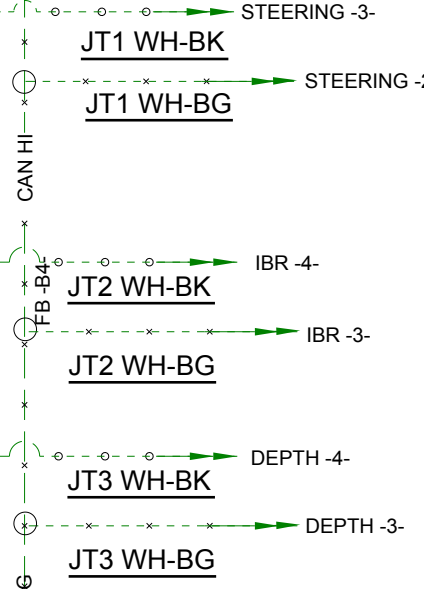
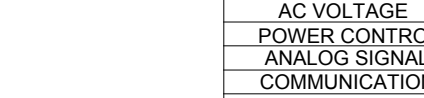
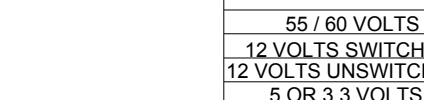
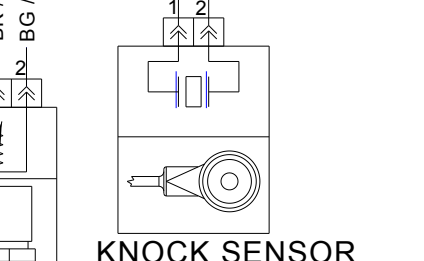
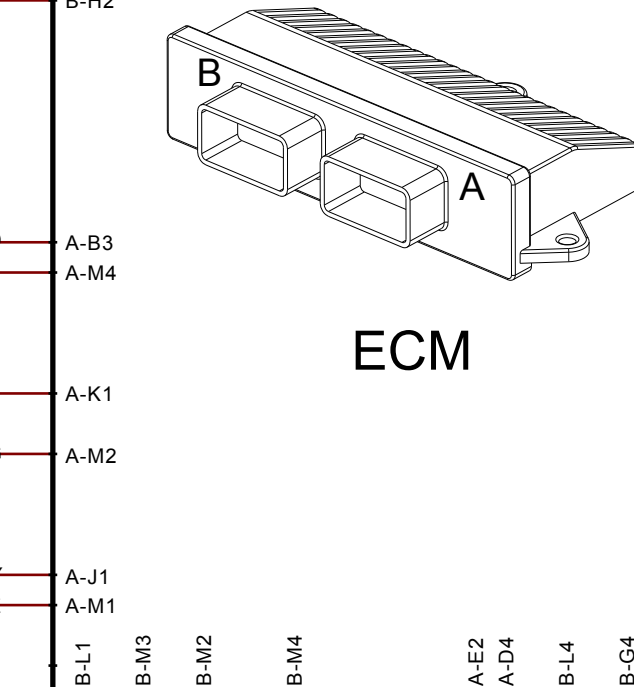
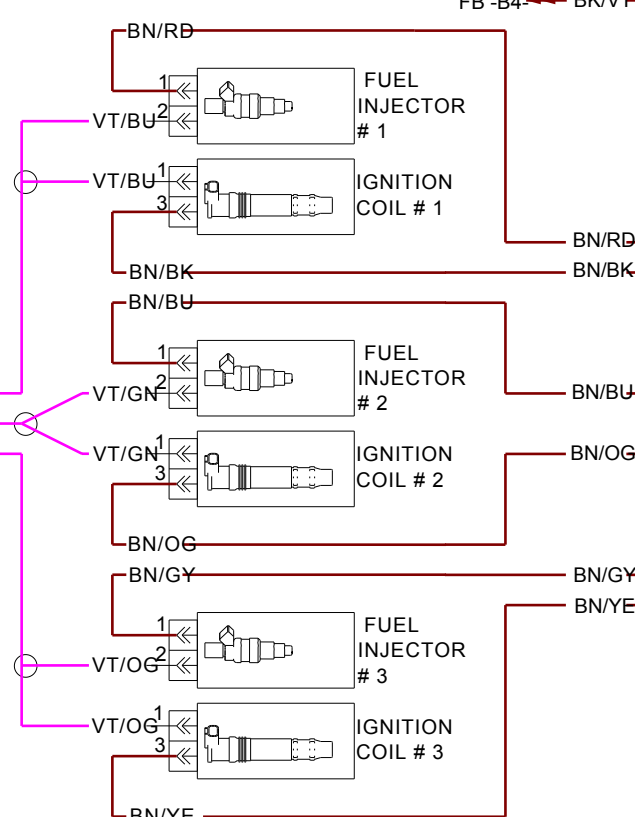
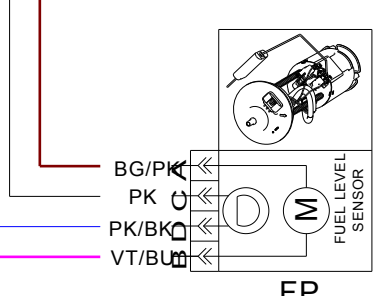
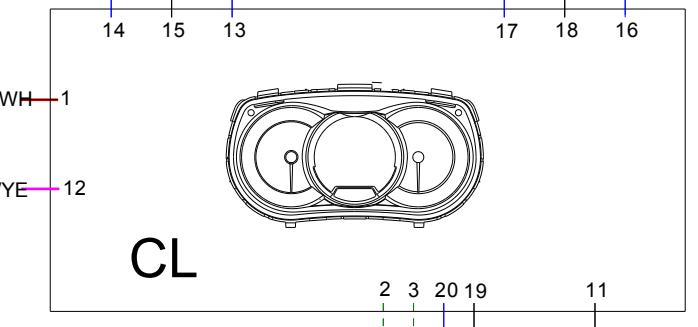
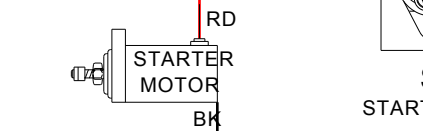
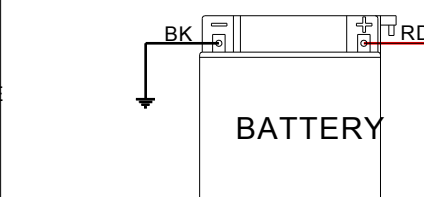
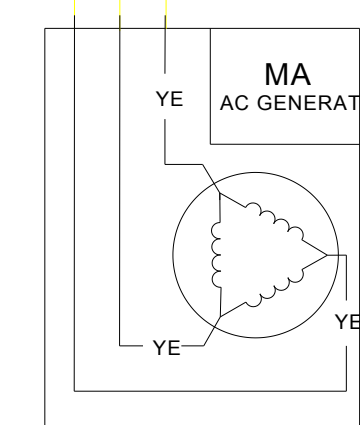
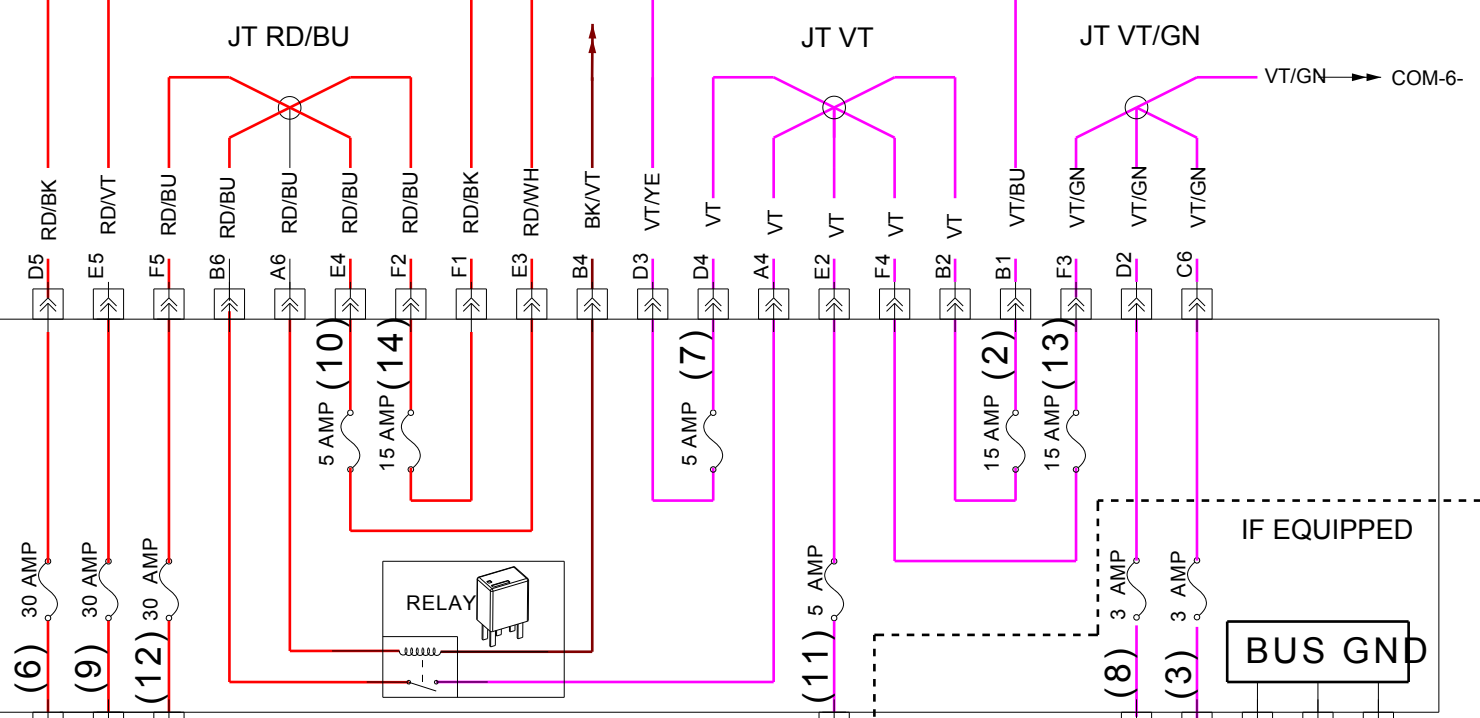
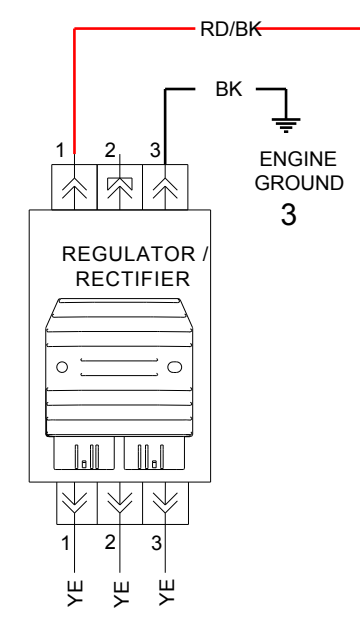
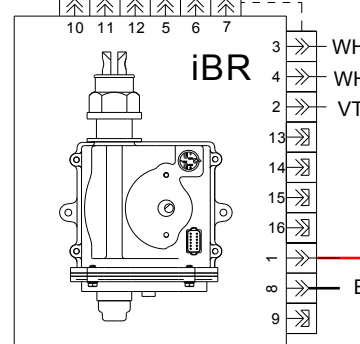

# 2018 SEA-DOO SOUND SYSTEM

## 2 SPEAKERS WITH BLUETOOTH DONGLE

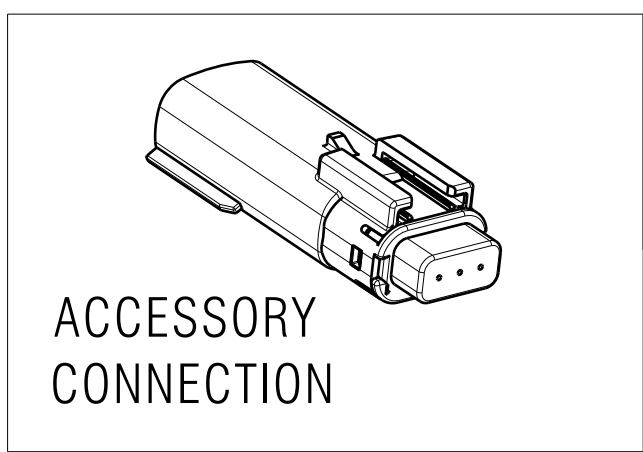

2 VT / YE  
3 BK  
1 RD / BK

1 VT / YE  
3 BK  
2 VT / BU  
5 LT GN / BU  
6 LT GN / OR  
7 GN / BG  
8 GN / LT GN

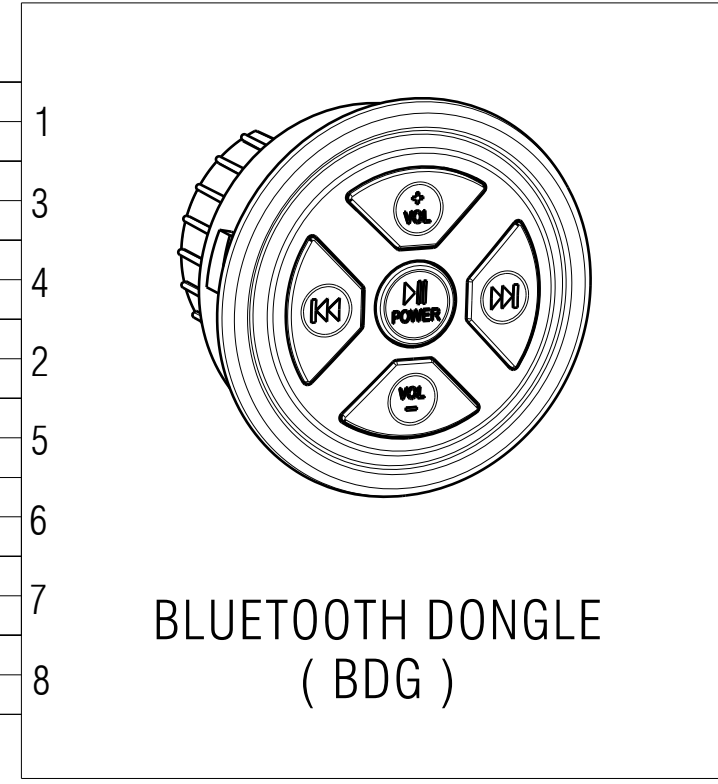

### LEGEND

WH = WHITE	BK = BLACK
RD = RED	YE = YELLOW
VT = VIOLET	BG = BEIGE (TAN)
GN = GREEN	BN = BROWN
GY = GREY	BU = BLUE
PK = PINK	OG = ORANGE

⊗ : JUNCTION POSITION  
 x---x : CAN HI WIRE  
 ○---○ : CAN LO WIRE

### LINE TYPE

55 / 60 VOLTS	
12 VOLTS SWITCHED	
12 VOLTS UNSWITCHED	
5 OR 3.3 VOLTS	
DIGITAL SIGNAL	
AC VOLTAGE	
POWER CONTROL	
ANALOG SIGNAL	
COMMUNICATION	
A-D GROUND	
POWER GROUND	

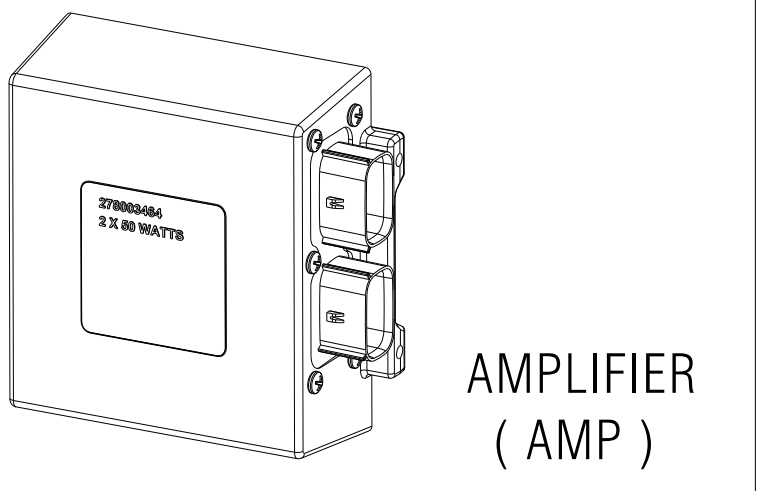
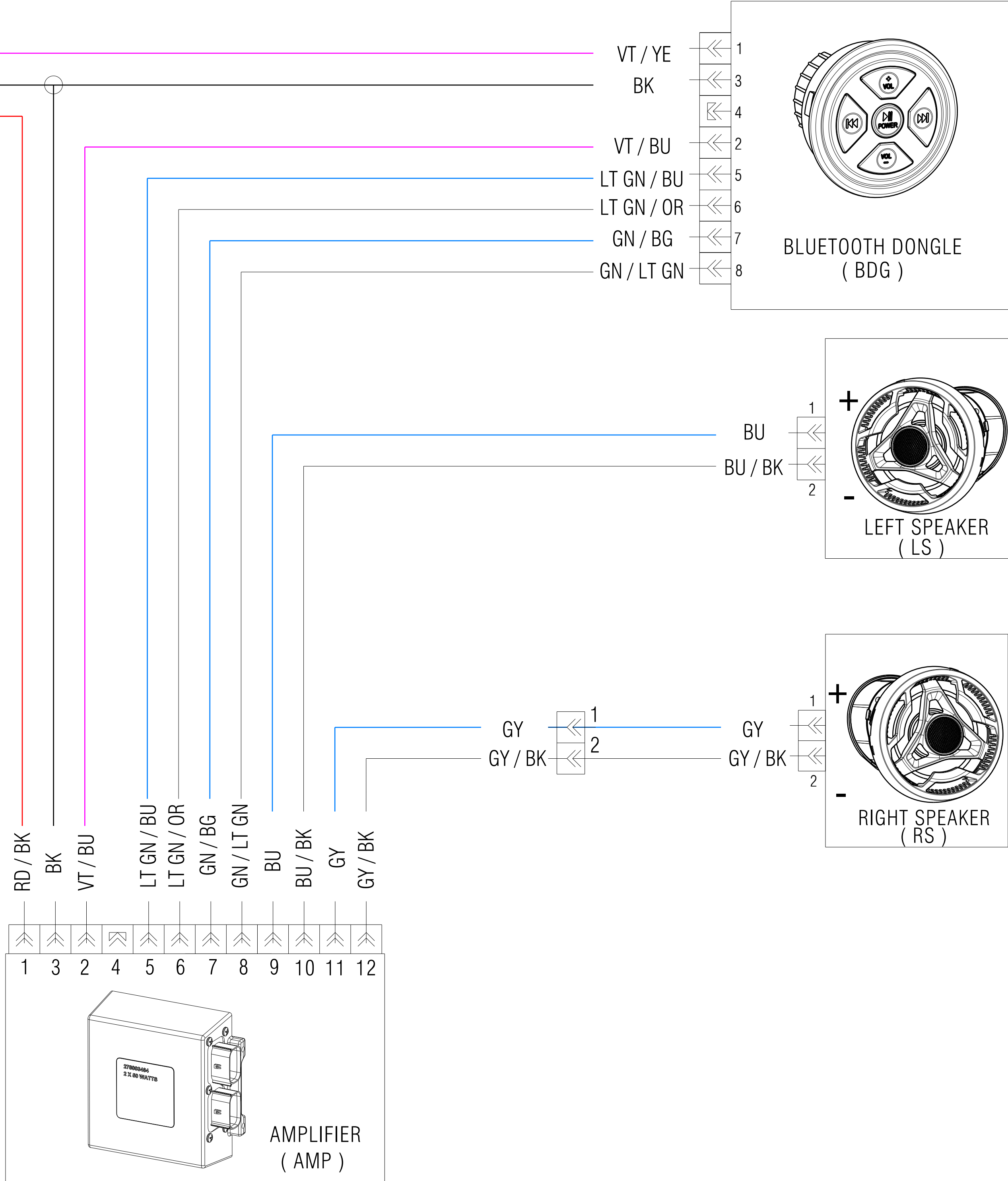

# 2018 SEA-DOO USB CHARGER

with DC Converter

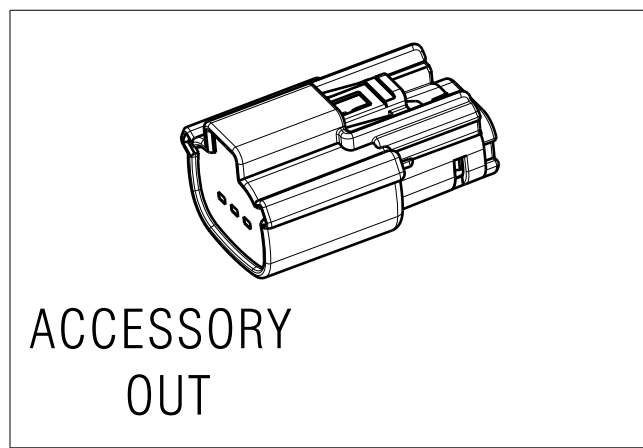

3 BK  
2 VT / YE  
1 RD / BK

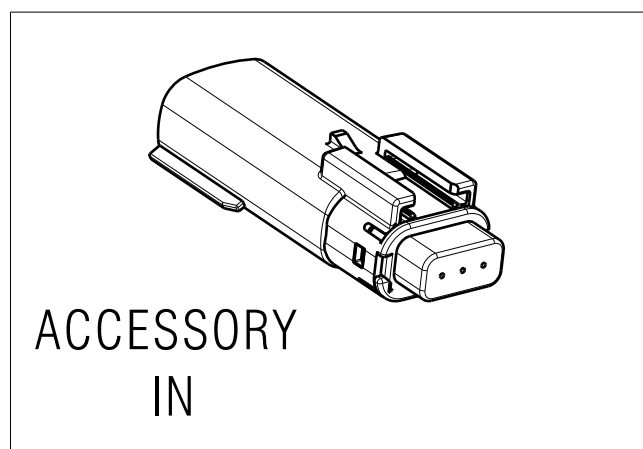

1 RD / BK  
2 VT / YE  
3 BK

LINE TYPE	
55 / 60 VOLTS	
12 VOLTS SWITCHED	
12 VOLTS UNSWITCHED	
5 OR 3.3 VOLTS	
DIGITAL SIGNAL	
AC VOLTAGE	
POWER CONTROL	
ANALOG SIGNAL	
COMMUNICATION	
A-D GROUND	
POWER GROUND	

## LEGEND

WH = WHITE    BK = BLACK  
RD = RED      YE = YELLOW  
VT = VIOLET    BG = BEIGE (TAN)  
GN = GREEN    BN = BROWN  
GY = GREY     BU = BLUE  
PK = PINK      OG = ORANGE

: JUNCTION POSITION  
x - - - x - - : CAN HI WIRE  
o - - - o - - : CAN LO WIRE

