

**ENGINE REMOVAL
AND
INSTALLATION –
1630 ACE**

Engine Removal and Installation

Figure 1. Engine Supports

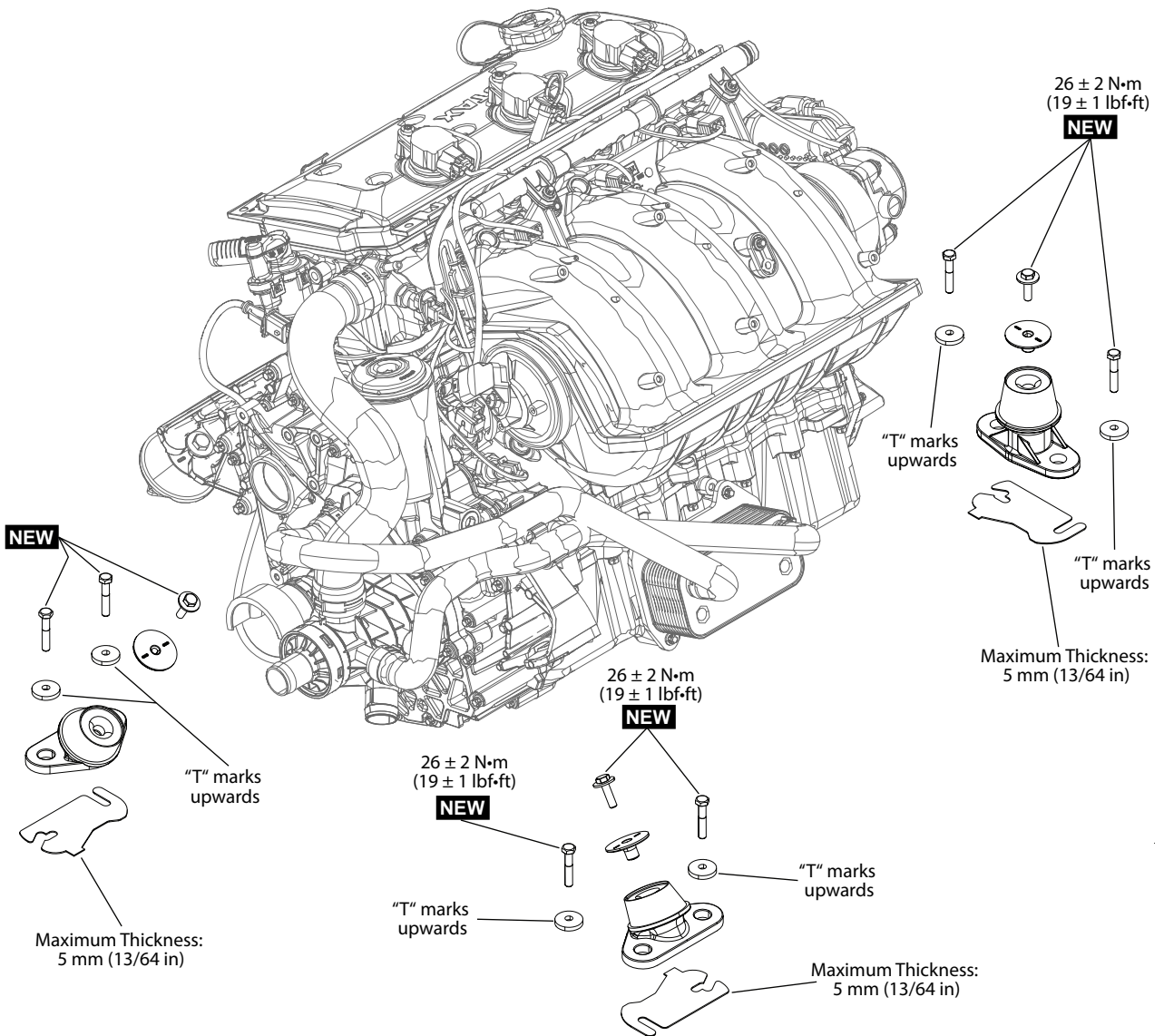

NEW = Component must be replaced when removed.

ENGINE SUPPORTS

170 models shown

General

⚠ WARNING

When electrically disconnecting or removing the throttle body from the intake manifold, always remove the tether cord from the engine cut-off switch and disconnect the battery.

⚠ WARNING

Always disconnect battery prior to working on the fuel system. Always disconnect battery exactly in the specified order, BLACK (-) cable first. Electrical connections should be disconnected prior to disconnecting fuel lines.

⚠ WARNING

Fuel is flammable and explosive under certain conditions. Work in a well ventilated area. Do not smoke or allow open flames or sparks in the vicinity.

⚠ WARNING

Fuel lines remain under pressure at all times. Always proceed with care and use appropriate safety equipment when working on a pressurized fuel system. Wear safety glasses. Do not allow fuel to spill on hot engine parts and/or on electrical connectors. Proceed with care when removing or installing high pressure test equipment, or disconnecting fuel line connections. Wipe off any fuel spillage in the bilge. Never use a hose pincher on high pressure hoses.

Cover the fuel line connection with an absorbent shop rag before disconnecting them. Slowly disconnect the fuel hose to minimize spilling.

When the repair is completed, ensure the hose from the fuel rail to the fuel pump is properly connected and secured in its support.

⚠ WARNING

After working on the fuel system, always pressurize the fuel system and check for fuel leaks. Refer to *FUEL SYSTEM PRESSURIZATION* in *FUEL TANK AND FUEL PUMP* subsection.

⚠ WARNING

If a gasoline leak and/or odor is present, do not start the engine. Repair the leak.

Procedures

Removing the Engine - Guideline

1. Place vehicle on a workstation equipped with an engine-lifting hoist.
2. Remove the following components:
 - Engine Service Cover. Refer to the *Body* subsection
 - Jet pump housing. Refer to the *Jet Pump* subsection
 - Drive shaft. Refer to the *Drive Shaft* subsection
 - Muffler. Refer to the *Exhaust System* subsection
 - Intake manifold. Refer to *Intake Manifold* subsection.
3. Disconnect the battery. Refer to *Charging System* subsection.

NOTICE

Always disconnect BLACK (-) cable first, then the RED (+) cable.

4. Drain engine coolant. Refer to *Cooling System* subsection.
5. Disconnect the following:
 - EGTS
 - iBR connector
 - Water temperature sensor (if equipped)
 - Depth finder (if equipped)
 - Live well pump (if equipped)
 - Engine ground cables
 - Magneto connector from the voltage regulator/rectifier.
 - Voltage Regulator/Rectifier connector
 - ECMA connector
6. Unplug HIC connector.

Figure 2.

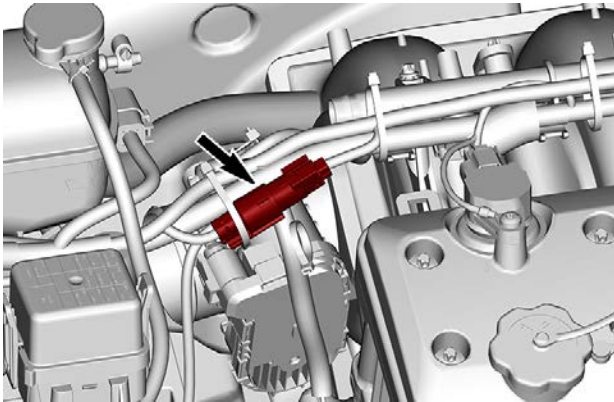

7. Remove main wiring harness from engine by cutting all locking ties between the aft and the air intake silencer.
8. Place a rag around fuel hose fitting. Disconnect fuel inlet hose from fuel rail using the fuel hose disconnect tool.

Figure 3.

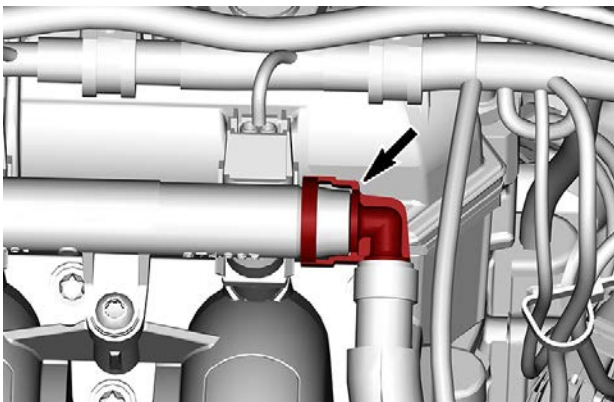

9. On supercharged models, disconnect both hoses from the supercharger.
10. Disconnect the blow-by valve hose.
11. Disconnect the ride plate hoses from water pump housing.
12. Remove the engine mounting screws.

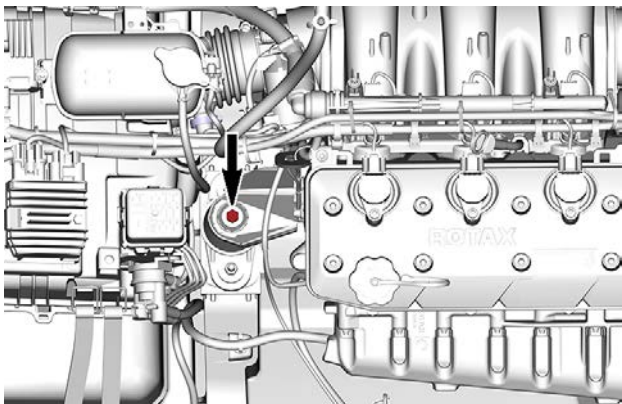
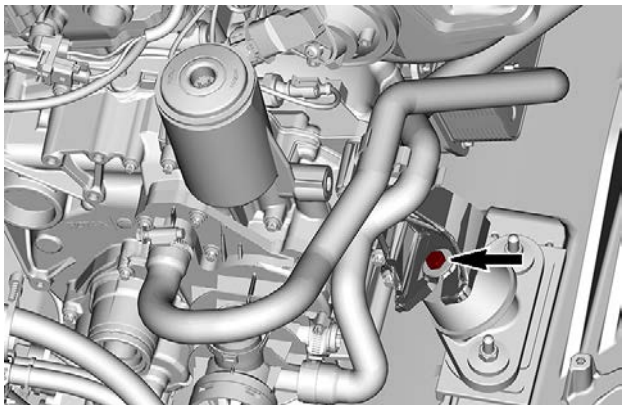
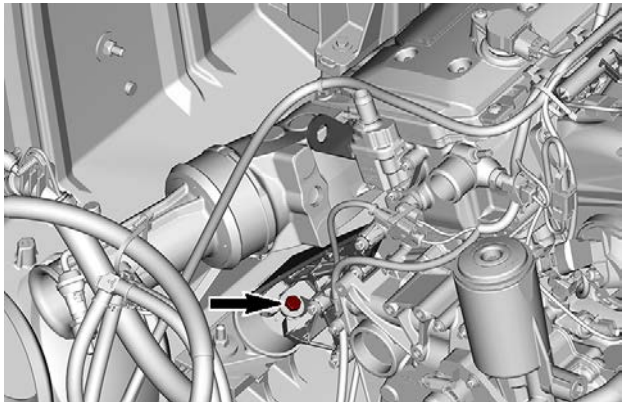
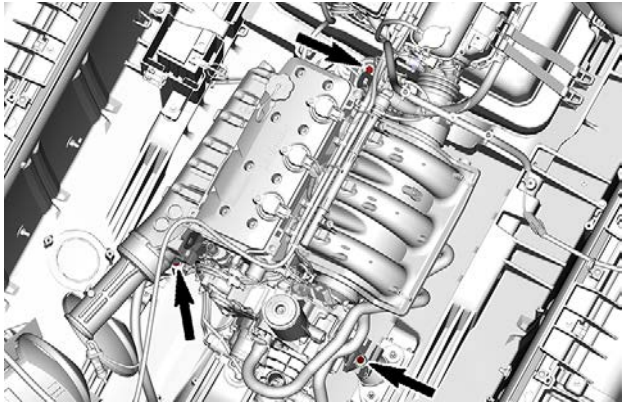

13. Cut any locking ties from hoses or wiring harness that prevent engine removal.
14. Slightly lift the engine using a suitable lifting device.

Figure 4.

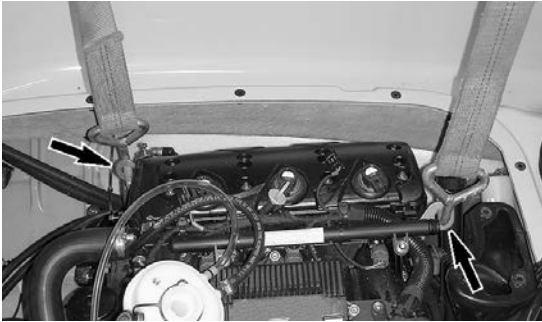

15. Disconnect water hoses from exhaust manifold.
16. Disconnect the starter cable from the starter.
17. Disconnect the engine ground cable located under the exhaust manifold.

Figure 5. Typical

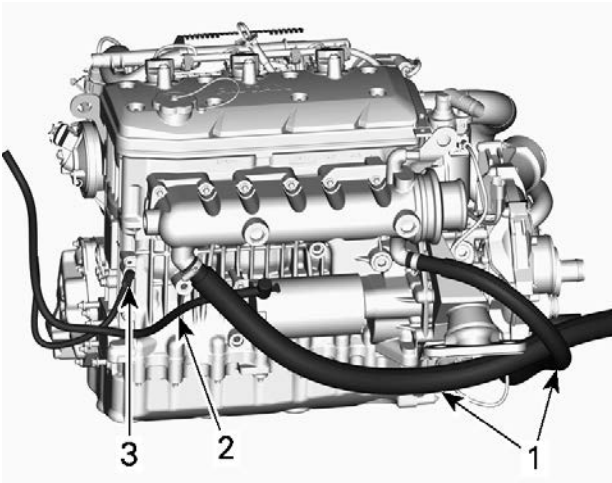
**TYPICAL**

1. Exhaust manifold water hoses
2. Starter cable
3. Engine ground cable

18. Disconnect coolant tank hose from water pump housing.
19. Carry on engine lifting to remove it from the body opening.

NOTE: Be careful not hit any engine component during engine removal.

Installing the Engine

The installation is the reverse of the removal procedures. However pay attention to the following.

NOTICE

Whenever engine is removed from watercraft, engine alignment must be performed at reinstallation.

1. Wipe off any spillage in bilge. Clean with the PRO C1 cleaner and degreaser.

Service Product

PRO C1 cleaner and degreaser

2. Check tightness and condition of engine rubber mounts. Refer to procedure in this subsection.
3. Before completely lowering engine, install ground cable, starter cable and water hoses on exhaust manifold. Follow these guide lines.

Service Product
Loctite (blue)
Neoprene paint

- Ensure contact surface is perfectly clean then reconnect ground cable to engine.
- Apply blue Loctite on threads of ground cable screw or use a new screw with self-locking product.
- Install and secure the ground cable.
- Tighten starter cable nut.
- To avoid potential corrosion of ground and starter cable, apply neoprene paint on bolt and eyelet connector.
- Install protective cap over the starter cable end.
- Connect exhaust manifold water inlet and outlet hoses.
- Connect coolant hoses to water pump housing.

Tightening Torque	
Ground cable screw	10 ± 2 Nm (89 ± 18 lbf-in)
Starter cable nut	10 ± 1 Nm (89 ± 9 lbf-in)
Exhaust manifold hose clamps	1.7 ± 0.2 Nm (15 ± 2 lbf-in)
Water pump hose clamps	3.5 ± .5 Nm (31 ± 4 lbf-in)

4. Place engine into vehicle.
5. Install engine support screws. Do not apply threadlocker to engine support screws and do not tighten yet.
6. Align engine. Refer to procedure in this subsection for complete procedure.

NOTICE

The engine alignment must be completed before finalizing the engine installation.

7. Install and properly align exhaust pipe. Refer to *EXHAUST SYSTEM* subsection.
8. Refill the cooling system with appropriate type and amount of coolant and pressure test the cooling system. Refer to *Cooling system* subsection.
9. Reinstall all other removed parts.
10. Check hose condition and pressure test fuel system, refer to *FUEL SYSTEM* section.

⚠ WARNING

Whenever doing any type of repair on watercraft or if any components of the fuel system are disconnected, a pressure test must be done before starting engine.

11. Verify all electrical connections (ground wires and battery).
12. Verify the level of coolant and oil.
13. Run engine and ensure there is no leakage.

NOTICE

If watercraft is out of water, exhaust system must be cooled using the flush kit.

Performing the Engine Alignment

Engine alignment is required only when one of the following parts is removed and/or replaced with new one.

- Engine supports (from cylinder block)
- Engine mount base (more than one)
- Jet pump support
- Hull.

The vehicle must be supported practically on its complete length to avoid hull deformation. It is important to support from the edge of the rear end up to at least the front of the engine.

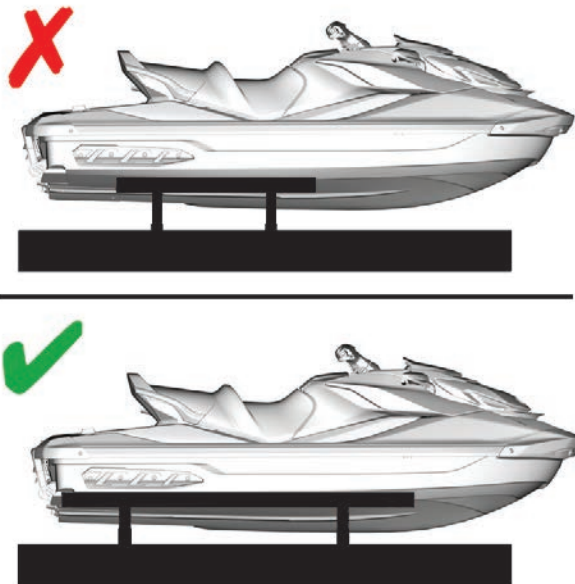

Figure 6. Typical



TYPICAL

To verify alignment of engine proceed as follows:

1. Remove the jet pump and drive shaft. Refer to *Jet pump* and *drive shaft* subsections.
2. Remove the drive shaft boot.
3. Assemble the alignment tool.

Engine alignment plate (P/N 529036224)	
Alignment shaft support (P/N 529035506)	

1. Install the alignment shaft support on engine alignment plate.
2. Secure using M8 x 25 x 1.25 hexagonal screws.

Figure 7.

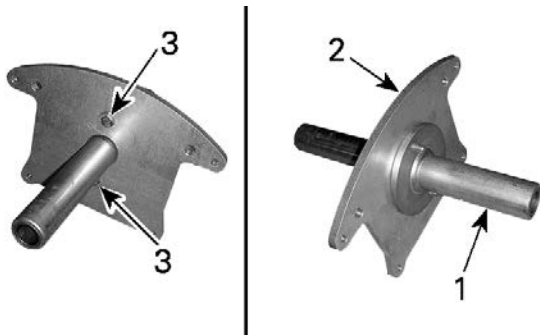

- i. Alignment shaft support
- ii. Engine alignment plate
- iii. M8 x 25 x 1.25 hexagonal screws

Tightening Torque	
Alignment tool screws	24.5 ± 3.5 Nm (18 ± 3 lbf-ft)

4. Install the alignment tool as follows.
 1. Position the alignment tool against the pump support.
 2. Push the alignment tool upward and hold it in this position.

Figure 8.

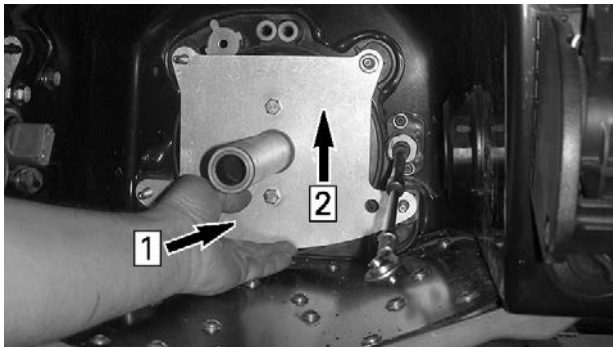

- i. Place alignment tool against pump support
- ii. Push alignment tool upward

3. Secure the tool using the jet pump retaining nuts.

Tightening Torque	
Jet pump retaining nut	24.5 ± 3.5 Nm (18 ± 3 lbf-ft)

5. Install the alignment shaft adapter on the end of the alignment shaft.

Alignment shaft adapter (P/N 529036521)	
Alignment shaft (P/N 295000141)	

6. Starting from the smaller end, trace two thin lines on alignment shaft.

Figure 9.

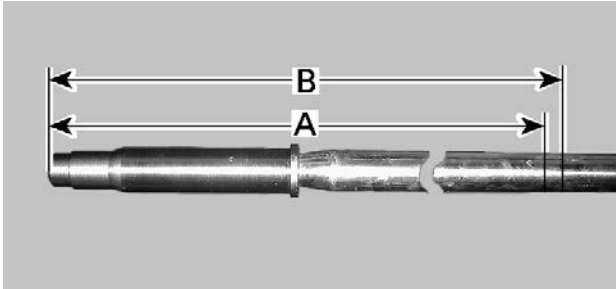

Models	Lines	Distance
Without iDF	Line A	at 729.1 mm (28.705 in)
	Line B	at 732.1 mm (28.823 in)
With iDF	Line A	at 684.5 mm (26.949 in)
	Line B	at 687.5 mm (27.067 in)

7. Remove the alignment shaft adapter from the end of the alignment shaft and install it in engine PTO housing.

NOTICE

Ensure alignment shaft adapter is fully inserted into the engine PTO housing.

Figure 10. Typical

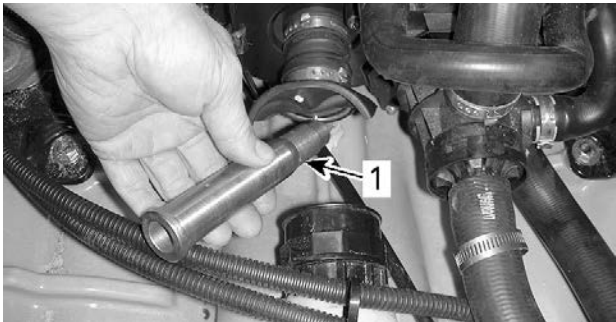

TYPICAL
1. Alignment shaft adapter

8. Carefully slide the alignment shaft through the engine alignment tool.

Figure 11.

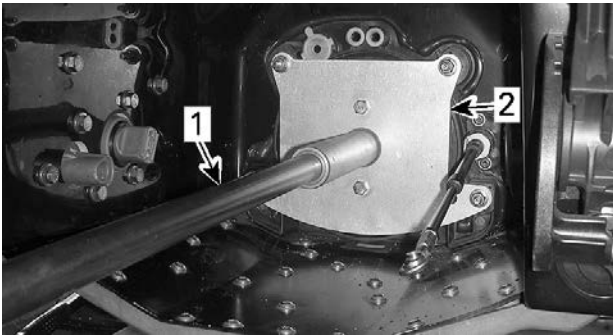

1. Alignment shaft
2. Alignment tool

9. Insert alignment shaft end into alignment shaft adapter. If the alignment is correct, the alignment shaft end should slide through the adapter.

NOTE: A small resistance during shaft insertion is normal.

10. If the alignment is incorrect, loosen engine mount retaining screws.

11. Add or remove shims as required.

NOTE: Shims location is between engine mount and hull.

NOTICE

Whenever shims are used to correct alignment, never install more than 5 mm (13/64 in) of shims.

Figure 12. Rear Starboard Engine Mount Shown

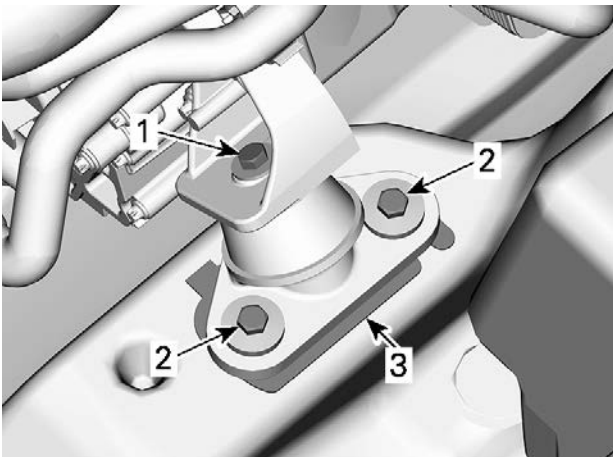

REAR STARBOARD ENGINE MOUNT SHOWN

1. Engine mounting screw
2. Engine mount retaining screws
3. Shim(s)

Figure 13. Front Engine Mount

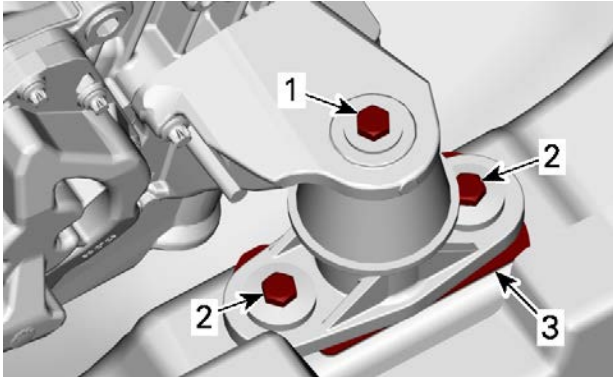

FRONT ENGINE MOUNT
 1. Engine mounting screw
 2. Engine mount retaining nuts
 3. Shim(s)

12. When engine alignment is correct, check the longitudinal position of engine.

Verifying the Engine Longitudinal Position

1. With alignment shaft installed, check the location of the lines (previously drawn at the beginning of the engine alignment procedure).
2. Engine is properly positioned longitudinally when the engine alignment tool is between both lines.
 - If **one** line is visible, the engine is properly positioned.
 - If **both** lines are visible, the engine must be moved forward.
 - If **no** line is visible, the engine must be moved rearward.

Figure 14. Proper Position

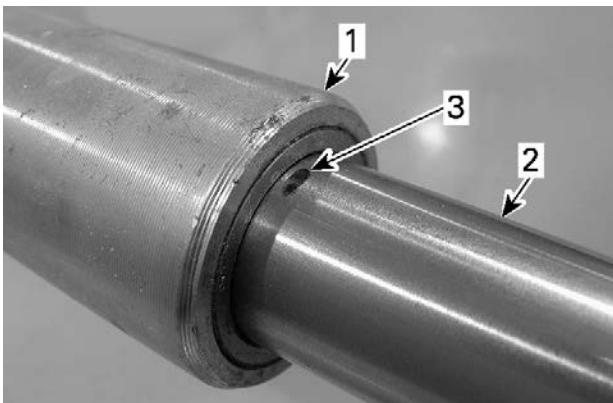

PROPER POSITION
 1. Engine alignment tool
 2. Alignment shaft
 3. Line B

3. When alignment and longitudinal position of engine are correct, tighten engine mount fasteners. Refer to *Engine Mounts* in this subsection.
4. Recheck engine alignment.

Engine Mounts

If engine mounts have been removed, apply blue Loctite on screw threads or use new screws with self-locking product.

Service Product	
Loctite (blue)	
Tightening Torque	
Engine mount screws	26 ± 2 Nm (19 ± 1 lbf-ft)

NOTE: Position conical spring washer with the "T" mark upwards.

Figure 15.

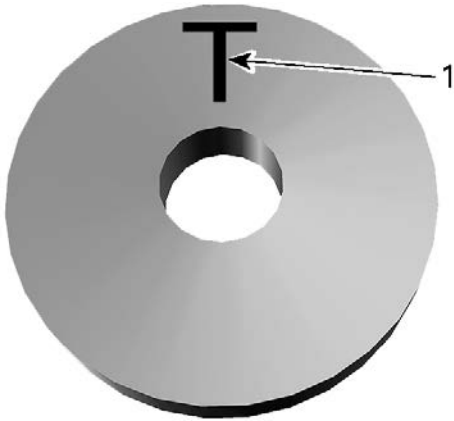

1. T mark